

**APPENDIX A –
PIER 4 REGULATED BUILDING
MATERIALS INSPECTION,
DATED OCTOBER 31, 2014**



October 31, 2014

Mr. Mark Larsen
Principal Scientist/Partner
Anchor QEA, LLC
720 Olive Way, Suite 1900
Seattle, Washington 98101

**RE: PIER 4
REGULATED BUILDING MATERIALS INSPECTION
PORT OF TACOMA
ON CALL ENVIRONMENTAL SUPPORT SERVICES
PROFESSIONAL SERVICES AGREEMENT NO. 069731 – TASK ORDER 8**

EMB Consulting Project 1232

Dear Mr. Larsen,

This report presents the findings of the limited regulated building materials inspection conducted by EMB Consulting, LLC for the Port of Tacoma (POT) Pier 4 structure, limited to the top side of the pier. According to project drawings and POT personnel, the project also excludes the Marine Operations Building and substation on the south side of Pier 4. The pier is scheduled to be demolished. The inspection was conducted to document the presence and location of regulated building materials, limited to asbestos, lead-based paint, and Universal Wastes, to ensure proper handling and disposal. The inspection was conducted by Elisabeth Black, CIH of EMB Consulting under the Anchor QEA contract with the Port of Tacoma (No. 069731 – Task Order 8).

This report is organized to provide the regulations, methods, and results of the inspection. A site plan was modified to provide approximate sample locations. Tables attached to the report provide a summary of results. Photographs of the inspected materials are also included. Finally, the laboratory analytical data are attached to this report.

Regulations

Asbestos

The Washington State Department of Labor and Industries Division of Occupational Safety and Health (DOSH) (WAC 296-62 and -155) and the Puget Sound Clean Air Agency (PSCAA, Regulation 3) require that building owners conduct a good faith survey for asbestos-containing materials (ACM) prior to demolition or renovation activities. The survey must be conducted by a certified asbestos building inspector under the Federal Asbestos Hazard and Emergency Response Act (AHERA, 40 CFR Part 763). Building materials that contain more than one percent asbestos are regulated as ACM and require special handling and disposal if disturbed or removed during project activities.



Lead in Paint

Prior to 1978, lead-containing pigment was sometimes added to paint. Old lead-based paint is the most significant source of lead exposure in the U.S. today. The Environmental Protection Agency (EPA) defines lead-based paint as paint containing 5,000 parts per million (ppm) of lead or more. That definition is used in this report to determine which painted materials may require special handling to avoid release of lead to the environment or worker exposure. Pier components with lead-based paint should not require special disposal. The lead in paint comprises too small of a contribution to the mass to trigger disposal restrictions. The presence of lead in paint will also not impact material recycling, if that is the fate of the material.

PCBs in Paint

The EPA regulates paint containing polychlorinated biphenyls (PCBs) at concentrations greater than or equal to 50 ppm as PCB bulk product waste (40 CFR 761.62). PCB bulk product waste means waste derived from manufactured products containing PCBs in a non-liquid state, at any concentration where the concentration at the time of designation for disposal is greater than or equal to 50 ppm PCBs.

Other Regulated Building Materials

The Washington State Department of Ecology regulates other building materials as Universal Wastes, as specified in WAC 173-303-572, to include High Intensity Discharge lamps (HID) (e.g., mercury vapor, metal halide, high pressure sodium).

Methods

Asbestos

EMB Consulting conducted the asbestos inspection of Pier 4 on October 17, 2014. Samples of suspect materials were collected in the field by Elisabeth Black, CIH, an AHERA-certified Building Inspector (expiration February 12, 2015). A complete list of the samples collected, sample locations, and results is provided in Table 1 attached to this report. A project plan was modified to include sample locations. The figure is attached to this report.

EMB Consulting marked each sample location on the site figure with a unique number corresponding to the sample number to identify the material from which the sample was collected. Sample containers were labeled at the time of sample collection with the Sample ID number. The labeled samples were then placed in a larger Ziploc™ type bag and sealed for additional protection during handling and transportation. Samples were recorded on a Chain of Custody for delivery to the laboratory for analysis.

Suspect asbestos samples and chain of custody were hand delivered to NVL Laboratories of Seattle, Washington for analysis. Suspect ACM bulk samples were analyzed using polarized light microscopy (PLM) by the Interim Method for Determination of Asbestos in Bulk Insulation Samples (EPA Method 600/M4 82 020). NVL Laboratories is accredited for asbestos analysis by the National Institute of Standards and Technology (NIST) under the National Voluntary Laboratory Accreditation Program (NVLAP). Materials were considered to be positive for asbestos if they contained more than one percent asbestos.



Lead and PCBs in Paint

Paint chip samples were collected from 12 locations to evaluate concentrations of lead. Of those, three were selected for additional analysis for PCBs in paint. Sample locations are indicated on the figure provided with this report.

All 12 paint chip samples were analyzed for lead by NVL Laboratories using Flame Atomic Absorption in accordance with EPA Method 7000B. Results are provided in Table 2 of Appendix B.

Three of the 12 paint chip samples were also analyzed for PCBs by Analytical Resources, Inc. in Tukwila, Washington using GC/ECD in accordance with EPA Method SW 8082A. Results are provided in Table 3.

Other Regulated Building Materials

EMB Consulting conducted a visual inventory for other hazardous building materials on Pier 4.

Results and Conclusions

Asbestos

The results of the asbestos survey are summarized in this section. Table 1 provides the analytical results for the two suspect asbestos bulk samples collected by EMB Consulting for analysis. Laboratory certificates of analysis and custody forms are attached to this report.

Only the fender system pier cap fabric sample was confirmed as ACM (Sample Id 1232-02A). If this material will be disturbed during the Pier 4 demolition project, the confirmed ACM must be removed, handled, and disposed by Washington-certified asbestos abatement workers in compliance with applicable regulations.

Lead and PCBs in Paint

A summary of the paint chip sampling results for lead is presented in Table 2. The results of the paint chip sampling can be summarized as follows:

- Yellow paint on concrete barriers (Sample ID 1232-01P) and bollard posts (Sample ID 1232-02P) was confirmed as lead-based paint.
- Orange paint on ship bollards (1232-09P) was confirmed as lead-based paint.

A summary of the paint chip sampling results for PCBs is presented in Table 3 of Appendix B. PCBs were not identified in any of the samples at or above the EPA criteria of 50 ppm for PCBs in paint. Based on this limited screening, paint waste will not be considered PCB bulk product waste during this project.

Other Regulated Building Materials

The EMB Consulting inventory documented the following Universal Wastes on Pier 4:

- Four light posts with high-intensity discharge lamps



If these materials will be removed during the Pier 4 demolition project, they will require removal, handling, and disposal as Universal Waste Lamps in accordance with WAC 173-303-573(5).

Limitations

Work for this project was performed, and this report prepared, in accordance with generally accepted professional practices for the nature and conditions of the work completed in the same or similar localities at the time the work was performed. It is intended for the exclusive use of Anchor QEA, LLC, the Port of Tacoma, and its contractors for specific application to the referenced property. No other warranty, express or implied, is made.

I appreciate the opportunity to be of service to you. Please contact me if you have questions regarding this report, or if you require additional information.

Sincerely,

A handwritten signature in blue ink that reads "E. Black".

Elisabeth Black, CIH
EMB Consulting LLC

Attachments:

Figure with Approximate Sample Locations

Site Photographs

Table 1 – Bulk Asbestos Sample Results, Pier 4, Port of Tacoma, Tacoma, Washington

Table 2 – Bulk Paint Results for Lead, Pier 4, Port of Tacoma, Tacoma, Washington

Table 3 – Bulk Paint Results for PCBs, Pier 4, Port of Tacoma, Tacoma, Washington

NVL Laboratories, Bulk Asbestos Fiber Analysis, NVL Batch #1418602.00, October 23, 2014

NVL Laboratories, Bulk Asbestos Fiber Analysis, NVL Batch #1417323.00, October 21, 2014

Analytical Resources, Inc., ARI Job No. ZG31, October 27, 2014

Asbestos Sample ID and Location

Lead/PCB Sample ID and Location

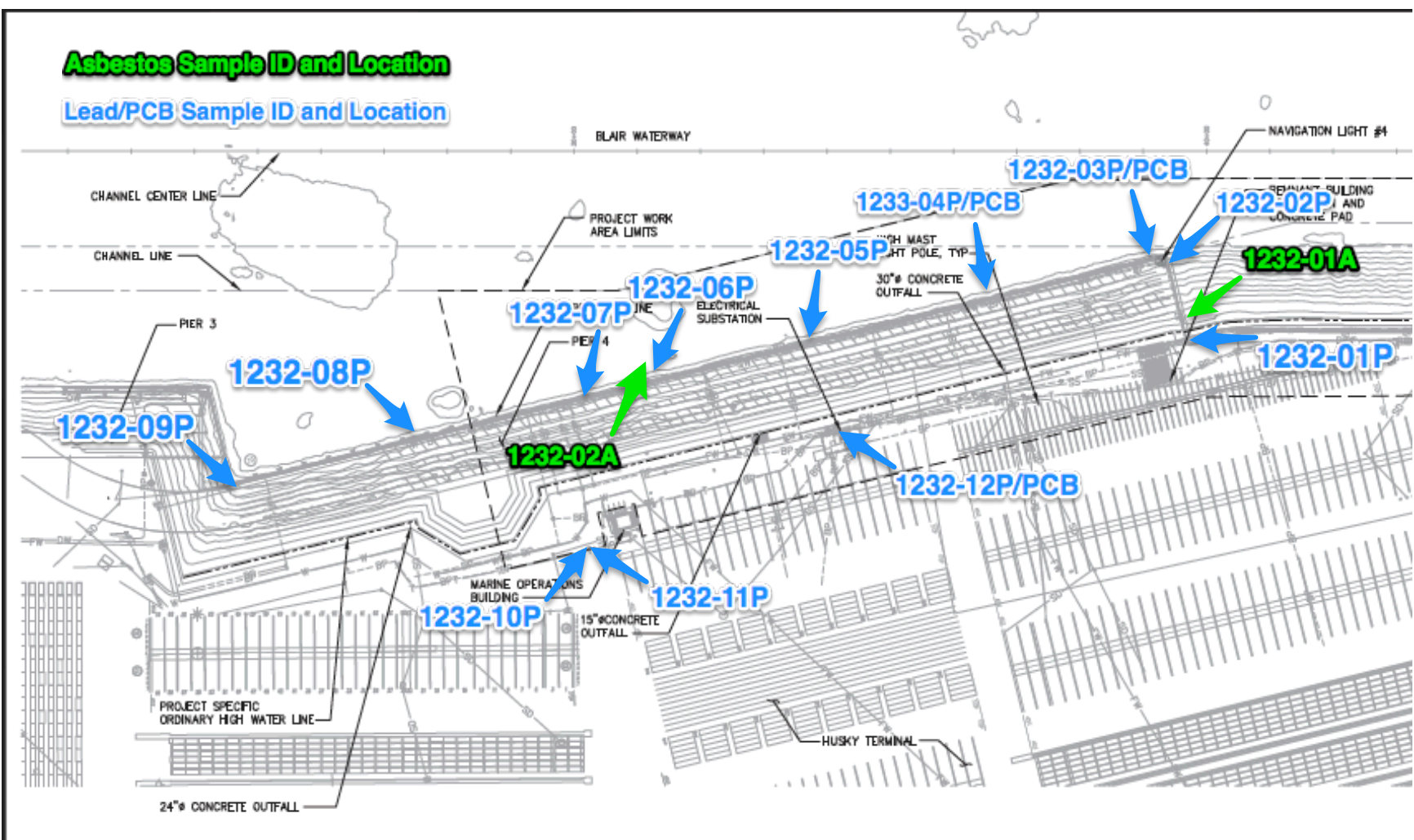

Table 1 - Bulk Asbestos Sample Results
Pier 4
Port of Tacoma
Tacoma, Washington

Sample ID	Material Description	Location	Asbestos (in Percent)
1232-01A	Wire Wrap L1: wrap (silver) L2: fabric (white)	SW End of Pier 4 Inside metal pipe-casing	L1: ND L2: ND
1232-02A	Fender System Pier Cap Material Asphaltic material with fabric (black/white)	Old fender system in water Directly N of Pier 4	5% chrysotile

ND = Non-Detect

**Table 2 - Bulk Paint Results for Lead
Pier 4
Port of Tacoma
Tacoma, Washington**

Sample ID	Material Description	Location	Lead (in mg/kg)	EPA Lead-Based Paint Criteria (in mg/kg)
1232-01P	Yellow Paint Barrier - Concrete	SE corner of Pier 4	16,000	5,000
1232-02P	Yellow Paint Bollard Post - Concrete and Metal	NE corner of Pier 4	40,000	
1232-03P	Yellow Paint Anchor Box - Metal	NE corner of Pier 4	<52	
1232-04P	Yellow Paint Ship Cleat - Metal	N side of Pier 4 along water SE end	390	
1232-05P	Blue Paint Bullrail Box - Metal	N side of Pier 4 along water SE end	<52	
1232-06P	Red and Grey Paint Bullrail Box - Metal	N side of Pier 4 along water Center	600	
1232-07P	Yellow Paint Ship Bollard - Metal	N side of Pier 4 along water Center	2,900	
1232-08P	Grey Paint Bullrail Box - Metal	N side of Pier 4 along water Center	<110	
1232-09P	Orange Paint Ship Bollard - Metal	N corner of Pier 4	47,000	
1232-10P	Black and Yellow Paint Light Pole - Metal	Light Pole E of Marine Ops Bldg	430	
1232-11P	Yellow Paint Light Pole Base - Concrete	Light Pole E of Marine Ops Bldg	<58	
1232-12P	Yellow Paint Railing - Metal	Railing around Substation S side of Pier 4	<63	

mg/kg - milligrams per kilogram

**Table 3 - Bulk Paint Results for PCBs
Pier 4
Port of Tacoma
Tacoma, Washington**

Sample ID	Material Description	Sample Location	PCB Results by Aroclor (in ppb)	EPA PCB Criteria (in ppb)
1232-03PCB	Yellow Paint Anchor Box - Metal	NE corner of Pier 4	Aroclor 1016 <790 Aroclor 1242 <790 Aroclor 1248 <790 Aroclor 1254 <790 Aroclor 1260 <790 Aroclor 1221 <790 Aroclor 1232 <790 Total PCBs ND	50,000
1232-04PCB	Yellow Paint Ship Cleat - Metal	N side of Pier 4 along water SE end	Aroclor 1016 <790 Aroclor 1242 <790 Aroclor 1248 <790 Aroclor 1254 <790 Aroclor 1260 <790 Aroclor 1221 <790 Aroclor 1232 <790 Total PCBs ND	
1232-12PCB	Yellow Paint Railing - Metal	Railing around Substation S side of Pier 4	Aroclor 1016 <2,700 Aroclor 1242 <2,700 Aroclor 1248 <2,700 Aroclor 1254 <2,700 Aroclor 1260 <2,700 Aroclor 1221 <2,700 Aroclor 1232 <2,700 Total PCBs ND	

PCBs - Polychlorinated Biphenyls

ppb - parts per billion

ND - Not detected at or above the laboratory limit of detection



Photograph 1: Pier 4, Wire Wrap inside Ducted Pipe (Sample 1232-01A)

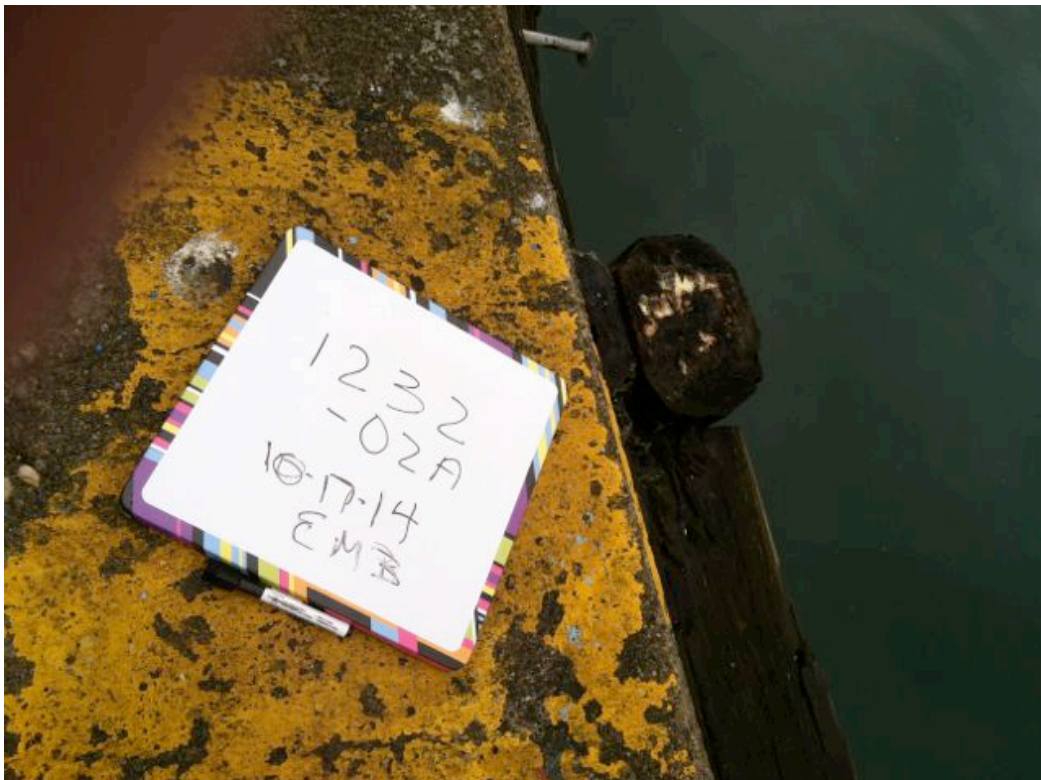

Photograph 2: Pier 4, Old Pier Cap Material (Sample 1232-02A)

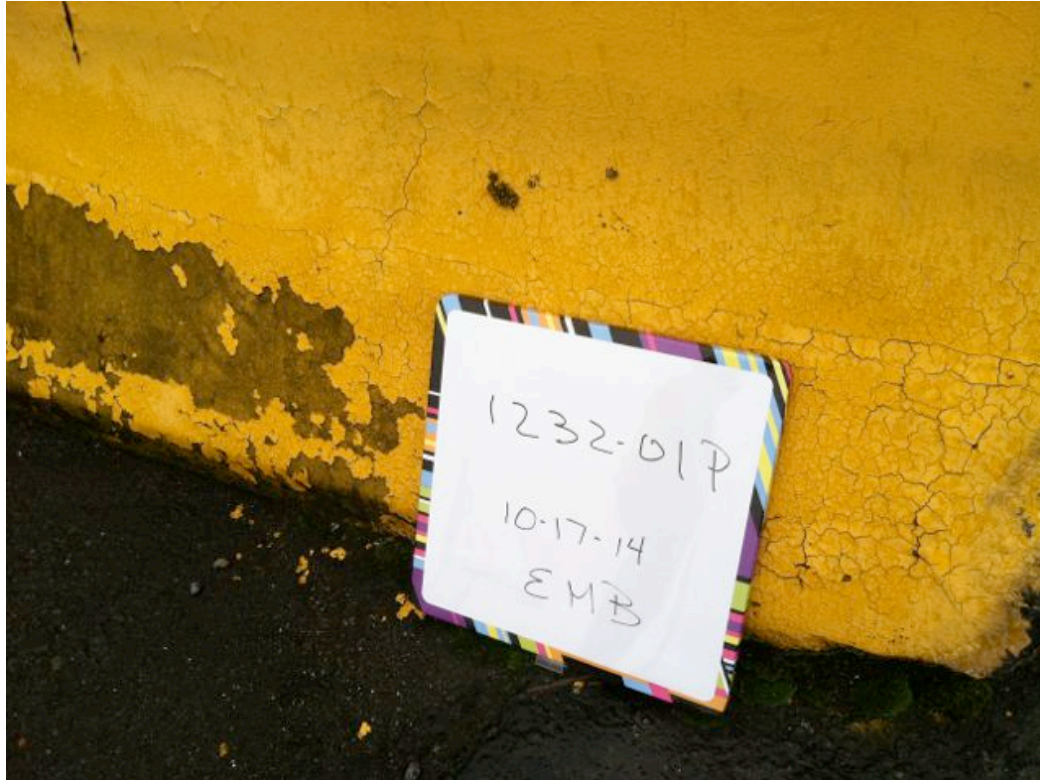

Photograph 3: Pier 4, Concrete Barrier – Yellow (Sample 1232-01P)



Photograph 4: Pier 4, Bollard Post - Yellow (Sample 1232-02P)



Photograph 5: Pier 4, Anchor Box - Yellow (Sample 1232-03P)



Photograph 6: Pier 4, Ship Cleat - Yellow (Sample 1232-04P)



Photograph 7: Pier 4, Bullrail Box - Blue (Sample 1232-05P)



Photograph 8: Pier 4, Bullrail Box - Red/Grey (Sample 1232-06P)



Photograph 9: Pier 4, Ship Bollard – Orange/Yellow (Sample 1232-07P)



Photograph 10: Pier 4, Ship Bollard – Orange (Sample 1232-09P)



Photograph 11: Pier 4, Light Pole – Black/Yellow (Sample 1232-10P)

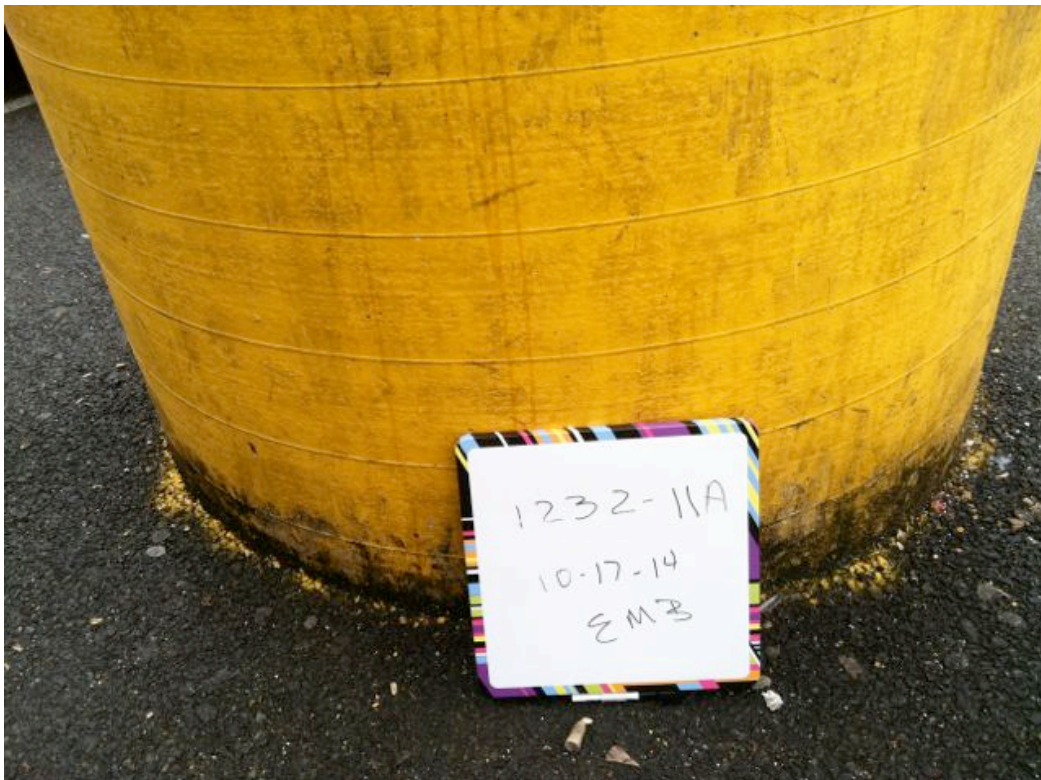

Photograph 12: Pier 4, Light Pole Base –Yellow (Sample 1232-11P)



Photograph 12: Pier 4, Railing at Substation –Yellow (Sample 1232-12P)



Bulk Asbestos Fibers Analysis

By Polarized Light Microscopy

Client: EMB Consulting, LLC
Address: PO Box 5171
Lynnwood, WA 98046

Batch #: 1418602.00

Client Project #: 1232
Date Received: 10/20/2014
Samples Received: 2
Samples Analyzed: 2
Method: EPA/600/R-93/116
& EPA/600/M4-82-020

Attention: Ms. Elisabeth Black
Project Location: POT - Pier 4

Lab ID: 14131787 Client Sample #: 1232-01A

Location: POT - Pier 4

Comments: Unsure of correct layer sequence

Layer 1 of 2	Description: Silver shiny plastic material	Non-Fibrous Materials:	Other Fibrous Materials:%	Asbestos Type: %
		Plastic	None Detected ND	

Layer 2 of 2	Description: Off-white woven fibers with soft white sticky material	Non-Fibrous Materials:	Other Fibrous Materials:%	Asbestos Type: %
		Binder/Filler, Miscellaneous particles, Fine particles	Cellulose 65%	

Lab ID: 14131788 Client Sample #: 1232-02A

Location: POT - Pier 4

Layer 1 of 1	Description: Black asphaltic built-up material with white woven fibers	Non-Fibrous Materials:	Other Fibrous Materials:%	Asbestos Type: %	
		Asphalt/Binder, Miscellaneous particles, Fine grains	Glass fibers 31%		Chrysotile 5%
			Cellulose 6%		

Sampled by: Client

Analyzed by: Matt Macfarlane

Date: 10/23/2014

DRAFT

Note: If samples are not homogeneous, then subsamples of the components were analyzed separately. All bulk samples are analyzed using both EPA 600/R-93/116 and 600/M4-82-020 Methods with the following measurement uncertainties for the reported % Asbestos (1%=0-3%, 5%=1-9%, 10%=5-15%, 20%=10-30%, 50%=40-60%). This report relates only to the items tested. If sample was not collected by NVL personnel, then the accuracy of the results is limited by the methodology and acuity of the sample collector. This report shall not be reproduced except in full, without written approval of NVL Laboratories, Inc. It shall not be used to claim product endorsement by NVLAP or any other agency of the US Government.

NVL Laboratories, Inc.

4708 Aurora Ave N, Seattle, WA 98103
 Tel: 206.547.0100 Emerg.Cell: 206.914.4646
 Fax: 206.634.1936 1.888.NVL.LABS (685.5227)

**CHAIN of CUSTODY
 SAMPLE LOG**

1418602

Client **EMB Consulting, LLC**
 Street **PO Box 5171**
 Lynnwood, WA 98046

NVL Batch Number _____
 Client Job Number **1232**
 Total Samples **2**

Project Manager **Ms. Elisabeth Black**
 Project Location **DOT - Pier 4**

Turn Around Time 1 Hr 6 Hrs 3 Days 10 Days
 2 Hrs 1 Day 4 Days
 4 Hrs 2 Days 5 Days
 Please call for TAT less than 24 Hrs

Phone: (206) 915-2395 Fax: _____

Email address **emblackconsult@gmail.com**

<input type="checkbox"/> Asbestos Air	<input type="checkbox"/> PCM (NIOSH 7400)	<input type="checkbox"/> TEM (NIOSH 7402)	<input type="checkbox"/> TEM (AHERA)	<input type="checkbox"/> TEM (EPA Level II)	<input type="checkbox"/> Other
<input checked="" type="checkbox"/> Asbestos Bulk	<input checked="" type="checkbox"/> PLM (EPA/600/R-93/116)	<input type="checkbox"/> PLM (EPA Point Count)	<input type="checkbox"/> PLM (EPA Gravimetry)	<input type="checkbox"/> TEM BULK	
<input type="checkbox"/> Mold/Fungus	<input type="checkbox"/> Mold Air	<input type="checkbox"/> Mold Bulk	<input type="checkbox"/> Rotometer Calibration		
METALS	Det. Limit	Matrix	RCRA Metals	<input type="checkbox"/> All 8	Other Metals
<input type="checkbox"/> Total Metals	<input type="checkbox"/> FAA (ppm)	<input type="checkbox"/> Air Filter	<input type="checkbox"/> Arsenic (As)	<input type="checkbox"/> Lead (Pb)	<input type="checkbox"/> All 3
<input type="checkbox"/> TCLP	<input type="checkbox"/> ICP (ppm)	<input type="checkbox"/> Drinking water	<input type="checkbox"/> Barium (Ba)	<input type="checkbox"/> Mercury (Hg)	<input type="checkbox"/> Copper (Cu)
<input type="checkbox"/> Cr 6	<input type="checkbox"/> GFAA (ppm)	<input type="checkbox"/> Dust/wipe (Area)	<input type="checkbox"/> Cadmium (Cd)	<input type="checkbox"/> Selenium (Se)	<input type="checkbox"/> Nickel (Ni)
		<input type="checkbox"/> Soil	<input type="checkbox"/> Chromium (Cr)	<input type="checkbox"/> Silver (Ag)	<input type="checkbox"/> Zinc (Zn)
<input type="checkbox"/> Other Types of Analysis	<input type="checkbox"/> Fiberglass	<input type="checkbox"/> Nuisance Dust	<input type="checkbox"/> Other (Specify) _____		
	<input type="checkbox"/> Silica	<input type="checkbox"/> Respirable Dust			

Condition of Package: Good Damaged (no spillage) Severe damage (spillage)

Seq. #	Lab ID	Client Sample Number	Comments (e.g Sample are, Sample Volume, etc)	A/R
1		1232-D1A		
2		1232-D2A		
3				
4				
5				
6				
7				
8				
9				
10				
11				
12				
13				
14				
15				

	Print Below	Sign Below	Company	Date	Time
Sampled by	Elisabeth Black	E. Black	EMB Consulting	10-20	3:00
Relinquished by	Elisabeth Black	E. Black	EMB Consulting	10-20	3:20
Received by	Tiffany Kannall	Tiffany Kannall	NVL	10-20-14	3:20pm
Analyzed by					
Results Called by					
Results Faxed by					

Special Instructions: Unless requested in writing, all samples will be disposed of two (2) weeks after analysis.

October 21, 2014

Elisabeth Black
EMB Consulting, LLC
PO Box 5171
Lynnwood, WA 98046



Laboratory | Management | Training

RE: Metals Analysis; NVL Batch # 1418601.00

Dear Ms. Black,

Enclosed please find the test results for samples submitted to our laboratory for analysis. Preparation of these samples was conducted following protocol outlined in EPA Method SW 846 -3051 unless stated otherwise. Analysis of these samples was performed using analytical instruments in accordance with U.S. EPA, NIOSH, OSHA and other ASTM methods.

For matrix materials submitted as paint, dust wipe, soil or TCLP samples, analysis for the presence of total metals is conducted using published U.S. EPA Methods. Paint and soil results are usually expressed in mg/Kg which is equivalent to parts per million (ppm). Lead (Pb) in paint is usually expressed in mg/Kg (ppm), Percent (%) or mg/cm² by area. Dust wipe sample results are usually expressed in ug/wipe and ug/ft². TCLP samples are reported in mg/L (ppm). For air filter samples, analyses are conducted using NIOSH and OSHA Methods. Results are expressed in ug/filter and ug/m³. Other matrix materials are analyzed accordingly using published methods or specified by client. The reported test results pertain only to items tested. Lead test results are not blank corrected.

For recent regulation updates pertaining to current regulatory levels or permissible exposure levels, please call your local regulatory agencies for more details.

This report is considered highly confidential and will not be released without your approval. Samples are archived for two weeks following analysis. Samples that are not retrieved by the client are discarded after two weeks.

Thank you for using our laboratory services. If you need further assistance please feel free to call us at 206-547-0100 or 1-888-NVLLABS.

Sincerely,

Nick Ly, Technical Director



1.888.NVL.LABS
1.888.(685.5227)
www.nvllabs.com

NVL Laboratories, Inc.
4708 Aurora Ave N, Seattle, WA 98103
p 206.547.0100 | f 206.634.1936

Analysis Report

Total Lead (Pb)

Client: EMB Consulting, LLC
 Address: PO Box 5171
 Lynnwood, WA 98046

Batch #: 1418601.00

Matrix: Paint
 Method: EPA 3051/7000B
 Client Project #: 1232
 Date Received: 10/20/2014
 Samples Received: 12
 Samples Analyzed: 12

Attention: Ms. Elisabeth Black
 Project Location: POT - Pier 4

Lab ID	Client Sample #	Sample Weight (g)	RL in mg/Kg	Results in mg/Kg	Results in percent
14131775	1232-01P	0.1987	51.0	16000.0	1.6000
14131776	1232-02P	0.1985	51.0	40000.0	4.0000
14131777	1232-03P	0.1952	52.0	< 52.0	<0.0052
14131778	1232-04P	0.1938	53.0	390.0	0.0390
14131779	1232-05P	0.1969	52.0	< 52.0	<0.0052
14131780	1232-06P	0.1583	64.0	600.0	0.0600
14131781	1232-07P	0.1895	54.0	2900.0	0.2900
14131782	1232-08P	0.0900	110.0	< 110.0	<0.0110
14131783	1232-09P	0.2057	50.0	47000.0	4.7000
14131784	1232-10P	0.0328	160.0	430.0	0.0430
14131785	1232-11P	0.1751	58.0	< 58.0	<0.0058
14131786	1232-12P	0.1630	63.0	< 63.0	<0.0063

Comments: Small sample size (<0.05g) for 1232-10P.

Sampled by: Client Analyzed by: Yasuyuki Hida Reviewed by: Nick Ly	Date Analyzed: 10/21/2014 Date Issued: 10/21/2014	 Nick Ly, Technical Director
--	--	--

mg/ Kg =Milligrams per kilogram

Percent = Milligrams per kilogram / 10000

Note : Method QC results are acceptable unless stated otherwise.

Unless otherwise indicated, the condition of all samples was acceptable at time of receipt.

RL = Reporting Limit

'<' = Below the reporting Limit

NVL Laboratories, Inc.

CHAIN of CUSTODY SAMPLE LOG

1418601

4708 Aurora Ave N, Seattle, WA 98103

Tel: 206.547.0100 Emerg. Cell: 206.914.4646

Fax: 206.634.1936 1.888.NVL.LABS (685.5227)

Client EMB Consulting, LLC

Street PO Box 5171

Lynnwood, WA 98046

NVL Batch Number _____

Client Job Number 1232

Total Samples 12

Turn Around Time

- 1 Hr 6 Hrs 3 Days 10 Days
 2 Hrs 1 Day 4 Days
 4 Hrs 2 Days 5 Days

Please call for TAT less than 24 Hrs

Email address emblackconsult@gmail.com

Project Manager Ms. Elisabeth Black

Project Location POT - Pier 4

Phone: (206) 915-2395 Fax: _____

<input type="checkbox"/> Asbestos Air	<input type="checkbox"/> PCM (NIOSH 7400)	<input type="checkbox"/> TEM (NIOSH 7402)	<input type="checkbox"/> TEM (AHERA)	<input type="checkbox"/> TEM (EPA Level II)	<input type="checkbox"/> Other
<input type="checkbox"/> Asbestos Bulk	<input type="checkbox"/> PLM (EPA/600/R-93/116)	<input type="checkbox"/> PLM (EPA Point Count)	<input type="checkbox"/> PLM (EPA Gravimetry)	<input type="checkbox"/> TEM BULK	
<input type="checkbox"/> Mold/Fungus	<input type="checkbox"/> Mold Air	<input type="checkbox"/> Mold Bulk	<input type="checkbox"/> Rotometer Calibration		
METALS	Det. Limit	Matrix	RCRA Metals	<input type="checkbox"/> All 8	Other Metals
<input checked="" type="checkbox"/> Total Metals	<input type="checkbox"/> FAA (ppm)	<input type="checkbox"/> Air Filter	<input checked="" type="checkbox"/> Paint Chips in %	<input checked="" type="checkbox"/> Lead (Pb)	<input type="checkbox"/> All 3
<input type="checkbox"/> TCLP	<input type="checkbox"/> ICP (ppm)	<input type="checkbox"/> Drinking water	<input type="checkbox"/> Paint Chips in cn	<input type="checkbox"/> Arsenic (As)	<input type="checkbox"/> Copper (Cu)
<input type="checkbox"/> Cr 6	<input type="checkbox"/> GFAA (ppl)	<input type="checkbox"/> Dust/wipe (Area)	<input type="checkbox"/> Waste Water	<input type="checkbox"/> Barium (Ba)	<input type="checkbox"/> Nickel (Ni)
	<input type="checkbox"/> Soil	<input type="checkbox"/> Other	<input type="checkbox"/> Cadmium (Cd)	<input type="checkbox"/> Chromium (Cr)	<input type="checkbox"/> Silver (Ag)
<input type="checkbox"/> Other Types of Analysis	<input type="checkbox"/> Fiberglass	<input type="checkbox"/> Nuisance Dust	<input type="checkbox"/> Other (Specify) _____		
	<input type="checkbox"/> Silica	<input type="checkbox"/> Respirable Dust			

Condition of Package: Good Damaged (no spillage) Severe damage (spillage)

Seq. #	Lab ID	Client Sample Number	Comments (e.g Sample are, Sample Volume, etc)	A/R
1		1232-01P		
2		-02P		
3		-03P		
4		-04P		
5		-05P		
6		-06P		
7		-07P		
8		-08P		
9		-09P		
10		-10P		
11		-11P		
12		-12P		
13				
14				
15				

	Print Below	Sign Below	Company	Date	Time
Sampled by	Elisabeth Black	E. Black	EMB Consulting	10/20	3:00
Relinquished by	Elisabeth Black	E. Black	EMB Consulting	10/20	3:20
Received by	Jiffy Kennell	Toby Hida	NVL	10/20/11	3:25 pm
Analyzed by	Yasuyuki Hida	[Signature]	[Signature]	10/20/11	10:40
Results Called by					
Results Faxed by					

Special Instructions: Unless requested in writing, all samples will be disposed of two (2) weeks after analysis.



Analytical Resources, Incorporated
Analytical Chemists and Consultants

October 27, 2014

Elisabeth Black, CIH
EMB Consulting, LLC.
PO Box 5171
Lynnwood, WA 98046

RE: Project: 1232
ARI Job No: ZG31

Dear Elisabeth:

Please find enclosed the original Chain-of-Custody (COC), sample receipt documentation, and the final report for the sample from the project referenced above. Analytical Resources, Inc. (ARI) accepted three solid samples in good condition on October 21, 2014. For further details regarding sample receipt, please refer to the enclosed Cooler Receipt Form.

The samples were analyzed for PCBs, as requested on the COC.

Sample 1232-12PCB has raised reporting limits due to limited sample volume.

There were no other anomalies associated with the analyses of the samples.

An electronic copy of this package will be kept on file with ARI. Should you have any questions regarding these results, please feel free to contact me at any time.

Sincerely,

ANALYTICAL RESOURCES, INC.

Kelly Bottem
Client Services Manager
(206) 695-6211
kellyb@arilabs.com
www.arilabs.com

cc: eFile ZG31

Chain of Custody Record & Laboratory Analysis Request

Analytical Resources, Incorporated
 Analytical Chemists and Consultants
 4611 South 134th Place, Suite 100
 Tukwila, WA 98168
 206-695-6200 206-695-6201 (fax)
 www.arilabs.com



Page: 1 of 1
 Date: 10/21/14 Ice Present? N
 No. of Coolers: 0 Cooler Temps: 21.1

ARI Assigned Number: 2631 Turn-around Requested: 7-day
 ARI Client Company: Elisa Beth Parcel Phone: 206-975-2385
 Client Contact: Elisa Beth Parcel
 Client Project Name: PCT - Pier 4
 Client Project #: 1232 Samplers: Elisabeth Parcel

Sample ID	Date	Time	Matrix	No. Containers	Analysis Requested			Notes/Comments
1232-D4 PCB	10/17		Point	1				
1232-03 PCB	"		"	1				
1232-12 PCB	"		"	1				

Comments/Special Instructions: 1

Relinquished by (Signature): <u>E. Parcel</u>	Received by (Signature): <u>[Signature]</u>
Printed Name: <u>Elisabeth Parcel</u>	Printed Name: <u>Jennifer Nilsep</u>
Company: <u>ARI</u>	Company: <u>ARI</u>
Date & Time: <u>10/21/14 11:30a</u>	Date & Time: <u>10/21/14 1130</u>

Limits of Liability: ARI will perform all requested services in accordance with appropriate methodology following ARI Standard Operating Procedures and the ARI Quality Assurance Program. This program meets standards for the industry. The total liability of ARI, its officers, agents, employees, or successors, arising out of or in connection with the requested services, shall not exceed the invoiced amount for said services. The acceptance by the client of a proposal for services by ARI release ARI from any liability in excess thereof, not withstanding any provision to the contrary in any contract, purchase order or co-signed agreement between ARI and the Client.

Sample Retention Policy: All samples submitted to ARI will be appropriately discarded no sooner than 90 days after receipt or 60 days after submission of hardcopy data, whichever is longer, unless alternate retention schedules have been established by work-order or contract.



Cooler Receipt Form

ARI Client: EMRB Consulting
 COC No(s): _____ NA
 Assigned ARI Job No: 2631

Project Name: POT-Pier 4
 Delivered by: Fed-Ex UPS Courier Hand Delivered Other: _____
 Tracking No: _____ NA

Preliminary Examination Phase:

Were intact, properly signed and dated custody seals attached to the outside of to cooler? YES NO
 Were custody papers included with the cooler? YES NO
 Were custody papers properly filled out (ink, signed, etc.) YES NO

Temperature of Cooler(s) (°C) (recommended 2.0-6.0 °C for chemistry) 21.1
 Time: _____
 If cooler temperature is out of compliance fill out form 00070F Temp Gun ID#: 90877952

Cooler Accepted by: Jm Date: 10/21/14 Time: 1130

Complete custody forms and attach all shipping documents

Log-In Phase:

Was a temperature blank included in the cooler? YES NO
 What kind of packing material was used? ... Bubble Wrap Wet Ice Gel Packs Baggies Foam Block Paper Other: _____
 Was sufficient ice used (if appropriate)? NA YES NO
 Were all bottles sealed in individual plastic bags? YES NO
 Did all bottles arrive in good condition (unbroken)? YES NO
 Were all bottle labels complete and legible? YES NO
 Did the number of containers listed on COC match with the number of containers received? YES NO
 Did all bottle labels and tags agree with custody papers? YES NO
 Were all bottles used correct for the requested analyses? YES NO
 Do any of the analyses (bottles) require preservation? (attach preservation sheet, excluding VOCs).. NA YES NO
 Were all VOC vials free of air bubbles? NA YES NO
 Was sufficient amount of sample sent in each bottle? YES NO
 Date VOC Trip Blank was made at ARI..... NA
 Was Sample Split by ARI : NA YES Date/Time: _____ Equipment: _____ Split by: _____

Samples Logged by: JS Date: 10-21-14 Time: 1203

**** Notify Project Manager of discrepancies or concerns ****

Sample ID on Bottle	Sample ID on COC	Sample ID on Bottle	Sample ID on COC

Additional Notes, Discrepancies, & Resolutions:

By: _____ Date: _____

			Small → "sm" (< 2 mm)
			Peabubbles → "pb" (2 to < 4 mm)
			Large → "lg" (4 to < 6 mm)
			Headspace → "hs" (> 6 mm)

Sample ID Cross Reference Report



ARI Job No: ZG31
Client: EMB Consulting LLC
Project Event: 1232
Project Name: POT-Pier 4

Sample ID	ARI Lab ID	ARI LIMS ID	Matrix	Sample Date/Time	VTSR
1. 1232-04PCB	ZG31A	14-22567	Paint	10/17/14	10/21/14 11:30
2. 1232-03PCB	ZG31B	14-22568	Paint	10/17/14	10/21/14 11:30
3. 1232-12PCB	ZG31C	14-22569	Paint	10/17/14	10/21/14 11:30

ORGANICS ANALYSIS DATA SHEET
PCB by GC/ECD Method SW8082A
Extraction Method: SW3580A
Page 1 of 1

Sample ID: 1232-04PCB
SAMPLE

Lab Sample ID: ZG31A
LIMS ID: 14-22567
Matrix: Paint
Data Release Authorized: *mm*
Reported: 10/27/14

QC Report No: ZG31-EMB Consulting LLC
Project: POT-Pier 4
1232
Date Sampled: 10/17/14
Date Received: 10/21/14

Date Extracted: 10/22/14
Date Analyzed: 10/23/14 17:13
Instrument/Analyst: ECD7/JGR
GPC Cleanup: No
Sulfur Cleanup: No
Acid Cleanup: Yes
Florisil Cleanup: No

Sample Amount: 1.01 g-as-rec
Final Extract Volume: 40.0 mL
Dilution Factor: 1.00
Silica Gel: Yes
Percent Moisture: NA

CAS Number	Analyte	LOQ	Result
12674-11-2	Aroclor 1016	790	< 790 U
53469-21-9	Aroclor 1242	790	< 790 U
12672-29-6	Aroclor 1248	790	< 790 U
11097-69-1	Aroclor 1254	790	< 790 U
11096-82-5	Aroclor 1260	790	< 790 U
11104-28-2	Aroclor 1221	790	< 790 U
11141-16-5	Aroclor 1232	790	< 790 U

Reported in µg/kg (ppb)

PCB Surrogate Recovery

Decachlorobiphenyl	89.0%
Tetrachlorometaxylene	71.8%

ORGANICS ANALYSIS DATA SHEET
PCB by GC/ECD Method SW8082A
Extraction Method: SW3580A
Page 1 of 1

Sample ID: 1232-03PCB
SAMPLE

Lab Sample ID: ZG31B
LIMS ID: 14-22568
Matrix: Paint
Data Release Authorized: *MMW*
Reported: 10/27/14

QC Report No: ZG31-EMB Consulting LLC
Project: POT-Pier 4
1232
Date Sampled: 10/17/14
Date Received: 10/21/14

Date Extracted: 10/22/14
Date Analyzed: 10/23/14 17:35
Instrument/Analyst: ECD7/JGR
GPC Cleanup: No
Sulfur Cleanup: No
Acid Cleanup: Yes
Florisil Cleanup: No

Sample Amount: 1.01 g-as-rec
Final Extract Volume: 40.0 mL
Dilution Factor: 1.00
Silica Gel: Yes
Percent Moisture: NA

CAS Number	Analyte	LOQ	Result
12674-11-2	Aroclor 1016	790	< 790 U
53469-21-9	Aroclor 1242	790	< 790 U
12672-29-6	Aroclor 1248	790	< 790 U
11097-69-1	Aroclor 1254	790	< 790 U
11096-82-5	Aroclor 1260	790	< 790 U
11104-28-2	Aroclor 1221	790	< 790 U
11141-16-5	Aroclor 1232	790	< 790 U

Reported in µg/kg (ppb)

PCB Surrogate Recovery

Decachlorobiphenyl	90.8%
Tetrachlorometaxylene	80.8%

ORGANICS ANALYSIS DATA SHEET
PCB by GC/ECD Method SW8082A
Extraction Method: SW3580A
Page 1 of 1

Sample ID: 1232-12PCB
SAMPLE

Lab Sample ID: ZG31C
LIMS ID: 14-22569
Matrix: Paint
Data Release Authorized: *MW*
Reported: 10/27/14

QC Report No: ZG31-EMB Consulting LLC
Project: POT-Pier 4
1232
Date Sampled: 10/17/14
Date Received: 10/21/14

Date Extracted: 10/22/14
Date Analyzed: 10/23/14 17:57
Instrument/Analyst: ECD7/JGR
GPC Cleanup: No
Sulfur Cleanup: No
Acid Cleanup: Yes
Florisil Cleanup: No

Sample Amount: 0.30 g-as-rec
Final Extract Volume: 40.0 mL
Dilution Factor: 1.00
Silica Gel: Yes
Percent Moisture: NA

CAS Number	Analyte	LOQ	Result
12674-11-2	Aroclor 1016	2,700	< 2,700 U
53469-21-9	Aroclor 1242	2,700	< 2,700 U
12672-29-6	Aroclor 1248	2,700	< 2,700 U
11097-69-1	Aroclor 1254	2,700	< 2,700 U
11096-82-5	Aroclor 1260	2,700	< 2,700 U
11104-28-2	Aroclor 1221	2,700	< 2,700 U
11141-16-5	Aroclor 1232	2,700	< 2,700 U

Reported in µg/kg (ppb)

PCB Surrogate Recovery

Decachlorobiphenyl	87.5%
Tetrachlorometaxylene	77.8%

ORGANICS ANALYSIS DATA SHEET
PCB by GC/ECD Method SW8082A
Extraction Method: SW3580A
Page 1 of 1

Sample ID: MB-102214
METHOD BLANK

Lab Sample ID: MB-102214
LIMS ID: 14-22567
Matrix: Paint
Data Release Authorized: *MW*
Reported: 10/27/14

QC Report No: ZG31-EMB Consulting LLC
Project: POT-Pier 4
1232
Date Sampled: NA
Date Received: NA

Date Extracted: 10/22/14
Date Analyzed: 10/23/14 16:07
Instrument/Analyst: ECD7/JGR
GPC Cleanup: No
Sulfur Cleanup: Yes
Acid Cleanup: Yes
Florisil Cleanup: No

Sample Amount: 1.00 g
Final Extract Volume: 40.0 mL
Dilution Factor: 1.00
Silica Gel: No
Percent Moisture: NA

CAS Number	Analyte	LOQ	Result
12674-11-2	Aroclor 1016	800	< 800 U
53469-21-9	Aroclor 1242	800	< 800 U
12672-29-6	Aroclor 1248	800	< 800 U
11097-69-1	Aroclor 1254	800	< 800 U
11096-82-5	Aroclor 1260	800	< 800 U
11104-28-2	Aroclor 1221	800	< 800 U
11141-16-5	Aroclor 1232	800	< 800 U

Reported in µg/kg (ppb)

PCB Surrogate Recovery

Decachlorobiphenyl	98.2%
Tetrachlorometaxylene	80.5%

SW8082/PCB SOIL/SOLID/SEDIMENT SURROGATE RECOVERY SUMMARY

Matrix: Paint

QC Report No: ZG31-EMB Consulting LLC
Project: POT-Pier 4
1232

<u>Client ID</u>	<u>DCBP % REC</u>	<u>DCBP LCL-UCL</u>	<u>TCMX % REC</u>	<u>TCMX LCL-UCL</u>	<u>TOT OUT</u>
MB-102214	98.2%	30-160	80.5%	30-160	0
LCS-102214	87.0%	30-160	70.0%	30-160	0
LCSD-102214	91.0%	30-160	77.0%	30-160	0
1232-04PCB	89.0%	30-160	71.8%	30-160	0
1232-03PCB	90.8%	30-160	80.8%	30-160	0
1232-12PCB	87.5%	30-160	77.8%	30-160	0

Medium Level Control Limits
Prep Method: SW3580A
Log Number Range: 14-22567 to 14-22569

ORGANICS ANALYSIS DATA SHEET
PCB by GC/ECD Method SW8082A
Page 1 of 1

Sample ID: LCS-102214
LCS/LCSD

Lab Sample ID: LCS-102214
LIMS ID: 14-22567
Matrix: Paint
Data Release Authorized: *MW*
Reported: 10/27/14

QC Report No: ZG31-EMB Consulting LLC
Project: POT-Pier 4
1232
Date Sampled: NA
Date Received: NA

Date Extracted LCS/LCSD: 10/22/14

Sample Amount LCS: 1.00 g-as-rec
LCSD: 1.00 g-as-rec

Date Analyzed LCS: 10/23/14 16:29
LCSD: 10/23/14 16:51
Instrument/Analyst LCS: ECD7/JGR
LCSD: ECD7/JGR

Final Extract Volume LCS: 40.0 mL
LCSD: 40.0 mL
Dilution Factor LCS: 1.00
LCSD: 1.00

GPC Cleanup: No
Sulfur Cleanup: Yes
Acid Cleanup: Yes
Florisil Cleanup: No

Silica Gel: No

Percent Moisture: NA

Analyte	LCS	Spike Added-LCS	LCS Recovery	LCSD	Spike Added-LCSD	LCSD Recovery	RPD
Aroclor 1016	16500	20000	82.5%	17800	20000	89.0%	7.6%
Aroclor 1260	18600	20000	93.0%	19400	20000	97.0%	4.2%

PCB Surrogate Recovery

	LCS	LCSD
Decachlorobiphenyl	87.0%	91.0%
Tetrachlorometaxylene	70.0%	77.0%

Results reported in µg/kg (ppb)
RPD calculated using sample concentrations per SW846.

**APPENDIX B –
STORMWATER POLLUTION
PREVENTION PLAN (PIER 4
SITE) DATED JANUARY 26,
2015**

Stormwater Pollution Prevention Plan

for the

Pier 4 Phase 1 Removal Action Project (Pier 4 Site)

Prepared for
Port of Tacoma

Owner	Developer	Operator/Contractor
Port of Tacoma	Port of Tacoma	TBD
P.O. Box 1837	P.O. Box 1837	XXX
Tacoma, WA 98401	Tacoma, WA 98401	XXX

Project Site Location

Pier 4, Husky Terminal
Project No. 091452
Contract No. 069982

Certified Erosion and Sediment Control Lead

TBD

SWPPP Prepared By

Jenn Stebbings, CPESC
Port of Tacoma, Environmental Analyst

SWPPP Preparation Date

01/26/2015

Approximate Project Construction Dates

03/01/2015

02/29/2016

Contents

1.0 Introduction	5
2.0 Site Description	7
2.1 Existing Conditions	7
2.2 Proposed Construction Activities.....	7
3.0 Construction Stormwater BMPs.....	8
3.1 The 12 BMP Elements	8
3.1.1 Element #1 – Mark Clearing Limits	8
3.1.2 Element #2 – Establish Construction Access.....	8
3.1.3 Element #3 – Control Flow Rates	9
3.1.4 Element #4 – Install Sediment Controls	9
3.1.5 Element #5 – Stabilize Soils.....	10
3.1.6 Element #6 – Protect Slopes	10
3.1.7 Element #7 – Protect Drain Inlets	11
3.1.8 Element #8 – Stabilize Channels and Outlets.....	11
3.1.9 Element #9 – Control Pollutants.....	12
3.1.10 Element #10 – Control Dewatering.....	13
3.1.11 Element #11 – Maintain BMPs	13
3.1.12 Element #12 – Manage the Project	13
4.0 Construction Phasing and BMP Implementation	16
5.0 Pollution Prevention Team.....	17
5.1 Roles and Responsibilities	17
5.2 Team Members	18
6.0 Site Inspections and Monitoring	18
6.1 Site Inspection.....	18
6.1.1 Site Inspection Frequency.....	19
6.1.2 Site Inspection Documentation.....	19
6.2 Stormwater Quality Monitoring	19
6.2.1 Turbidity.....	19
6.2.2 pH.....	20
7.0 Reporting and Recordkeeping	20
7.1 Recordkeeping	20
7.1.1 Site Log Book	20
7.1.2 Records Retention	20
7.1.3 Access to Plans and Records.....	21
7.1.4 Updating the SWPPP	21
7.2 Reporting.....	21
7.2.1 Discharge Monitoring Reports	21
7.2.2 Notification of Noncompliance	21

Appendix A – Site Plans	22
Appendix B – Construction BMPs	23
Appendix C – Alternative BMPs.....	24
Appendix D – Site Inspection Forms (and Site Log)	25

1.0 Introduction

This Stormwater Pollution Prevention Plan (SWPPP) has been prepared as part of the NPDES stormwater permit requirements for the Pier 4 Removal Action project (Project), located in Tacoma, Washington. The total project area is approximately 18 acres and includes a paved wharf, above- and belowground utilities, and other infrastructure that supports marine cargo transport at the Port of Tacoma's (Port) Husky Terminal located at 1101 Port of Tacoma Road, Tacoma, Washington, 98421.

The Project consists of removing the pier structure, including the existing bulkhead, decking, fender system and supporting batter piles. The existing crane beam and other crane appurtenances, bull rail, asphalt, ballast, and utilities will also be removed. The purpose of the project—in accordance with an Administrative Settlement Agreement and Order on Consent for Time Critical Removal Action entered into with the Environmental Protection Agency (EPA)—is to remove the pier in order to remediate sediment containing tributyltin (TBT).

Project activities will include demolition, pile extraction, excavation, dredging, and capping off and removing existing utilities. Upland activities are limited to demolition, excavation and trenching, utility removal, grading, and resurfacing. Dewatering at an off-site transload facility will be addressed in a separate document. The pier will not be replaced as part of this project.

The purpose of this SWPPP is to describe the proposed construction activities and all temporary and permanent erosion and sediment control (ESC) measures, pollution prevention measures, inspection/monitoring activities, and recordkeeping that will be implemented during the proposed project. The objectives of the SWPPP are to:

1. Implement Best Management Practices (BMPs) to prevent erosion and sedimentation, and to identify, reduce, eliminate or prevent stormwater contamination and water pollution from construction activity.
2. Prevent violations of surface water quality, ground water quality, or sediment management standards.
3. Prevent, during the construction phase, adverse water quality impacts including impacts on beneficial uses of the receiving water by controlling peak flow rates and volumes of stormwater runoff at the Permittee's outfalls and downstream of the outfalls.

This SWPPP was prepared using the Ecology SWPPP Template downloaded from the Ecology website on December 27, 2013. To the Port's knowledge, there has been no change in the template since that time. This SWPPP was prepared based on the

requirements set forth in the Construction Stormwater General Permit and the *Stormwater Management Manual for Western Washington* (SWMMWW 2012). The plan is divided into seven main sections with several appendices that include stormwater related reference materials. The topics presented in the each of the main sections are:

- Section 1 – INTRODUCTION. This section provides a summary description of the project, and the organization of the SWPPP document.
- Section 2 – SITE DESCRIPTION. This section provides a detailed description of the existing site conditions, proposed construction activities, and calculated stormwater flow rates for existing conditions and post-construction conditions.
- Section 3 – CONSTRUCTION BMPs. This section provides a detailed description of the BMPs to be implemented based on the 12 required elements of the SWPPP (SWMMWW 2012).
- Section 4 – CONSTRUCTION PHASING AND BMP IMPLEMENTATION. This section provides a description of the timing of the BMP implementation in relation to the project schedule.
- Section 5 – POLLUTION PREVENTION TEAM. This section identifies the appropriate contact names (emergency and non-emergency), monitoring personnel, and the on-site temporary erosion and sedimentation control inspector
- Section 6 – INSPECTION AND MONITORING. This section provides a description of the inspection and monitoring requirements such as the parameters of concern to be monitored, sample locations, sample frequencies, and sampling methods for all stormwater discharge locations from the site.
- Section 7 – RECORDKEEPING. This section describes the requirements for documentation of the BMP implementation, site inspections, monitoring results, and changes to the implementation of certain BMPs due to site factors experienced during construction.

Supporting documentation and standard forms are provided in the following Appendices:

- Appendix A – Site Plans
- Appendix B – Construction BMPs
- Appendix C – Alternative BMPs
- Appendix D – Site Log and Inspection Forms

2.0 Site Description

2.1 Existing Conditions

The proposed project site is located along the west side of the Blair Waterway, on the east side of the Port's "General Central Peninsula". A site vicinity map is provided in Appendix A. The Husky Terminal is approximately 91 acres in size and is currently an active, operating terminal that imports and exports container cargo. The project area is approximately 18 acres within the existing Husky Terminal. The topography of the site is generally flat.

The entire project is located on Port property and there are no drainage system tie-ins on the Husky Terminal to the City of Tacoma drainage system. Stormwater runoff discharges directly to the Blair Waterway. Blair Waterway is connected to Commencement Bay.

No critical areas such as wetlands, high erosion risk areas, or steep slopes (potential landslide area) are located on site.

TBT was detected above cleanup levels in the sediment immediately adjacent to the existing pier. The presence of TBT has been identified above cleanup levels at the ground surface below the pier to approximately 10.5 feet below ground surface.

2.2 Proposed Construction Activities

The existing Pier 4 structure including the existing bulkhead and supporting batter piles will be demolished. The existing fender system, asphalt pavement, ballast, utilities, will also be removed, along with the existing crane beam, bull rail and other appurtenances. Minor demolition work behind the bulkhead (i.e., pavement, water power, sanitary sewer, and storm drainage utilities) will also occur. The project will not increase the amount of on-site impervious pavement.

Sediment (both clean material and TBT-containing material) will be dredged from the area surrounding the demolished Pier 4 structure.

Two existing navigation lights will be relocated.

Construction activities will include site preparation, TESC installation, demolition, pile extraction, trenching, excavation, dredging, utility relocation, grading and asphalt paving.

The schedule and phasing of BMPs during construction is provided in Section 4.0.

The following summarizes details regarding site areas:

- Total project site area: 18 acres

- Percent impervious area before construction: 100.0 %
- Percent impervious area after construction: 100.0 %
- Upland disturbed area during construction: <0.5 acre
- Upland disturbed area that is characterized as impervious (i.e., access roads, staging, parking): <0.5 acre

3.0 Construction Stormwater BMPs

3.1 The 12 BMP Elements

3.1.1 Element #1 – Mark Clearing Limits

To protect adjacent properties and to reduce the area of soil exposed to construction, the limits of construction will be clearly marked before land-disturbing activities begin. Trees that are to be preserved, as well as all sensitive areas and their buffers, shall be clearly delineated, both in the field and on the plans. In general, natural vegetation and native topsoil shall be retained in an undisturbed state to the maximum extent possible. The BMPs relevant to marking the clearing limits that will be applied for this project include:

- **BMP C103: High Visibility Plastic or Metal Fence.** A temporary chain link fence, high visibility fence and/or silt fence will be installed to identify project limits. Demolition limits will be delineated in the field using paint, flagging and/or stakes.

Alternate BMPs for marking clearing limits are included in Appendix C as a quick reference tool for the on-site inspector in the event the BMP(s) listed above are deemed ineffective or inappropriate during construction. To avoid potential erosion and sediment control issues, the Certified Erosion and Sediment Control Lead will promptly initiate the implementation of one or more of the alternative BMPs listed in Appendix C after the first sign that existing BMPs are ineffective or failing.

3.1.2 Element #2 – Establish Construction Access

Construction access or activities occurring on unpaved areas shall be minimized, yet where necessary, access points shall be stabilized to prevent tracking sediment onto public roads, and wheel washing, street sweeping, and street cleaning shall be employed to prevent sediment from entering state waters. All wash wastewater shall be controlled on site. The specific BMPs related to establishing construction access that will be used on this project include:

- **BMP C105: Stabilized Construction Entrance/Exit.** Construction entrance/exit will be from an existing paved access route.

Alternate BMPs for marking clearing limits are included in Appendix C as a quick reference tool for the on-site inspector in the event the BMP(s) listed above are deemed ineffective or inappropriate during construction. To avoid potential erosion and sediment control issues, the Certified Erosion and Sediment Control Lead will promptly initiate the implementation of one or more of the alternative BMPs listed in Appendix C after the first sign that existing BMPs are ineffective or failing.

3.1.3 Element #3 – Control Flow Rates

In order to protect the surrounding properties and waterways downstream of the project site, stormwater discharges from the site will be controlled. The specific BMPs for flow control that shall be used on this project include:

- Since the site is currently 100% impervious, flow rates are not anticipated to increase. The removal of pavement from the over-water pier structure will reduce the amount of pollution-generating impervious surface coverage on the project site.
- **BMP C235: Wattles.** Straw wattles may be installed to control flow around the perimeter of the site, if needed.

Alternate BMPs for marking clearing limits are included in Appendix C as a quick reference tool for the on-site inspector in the event the BMP(s) listed above are deemed ineffective or inappropriate during construction. To avoid potential erosion and sediment control issues, the Certified Erosion and Sediment Control Lead will promptly initiate the implementation of one or more of the alternative BMPs listed in Appendix C after the first sign that existing BMPs are ineffective or failing.

3.1.4 Element #4 – Install Sediment Controls

All stormwater runoff from disturbed areas shall pass through an appropriate sediment removal BMP before leaving the construction site or prior to being discharged to an infiltration facility. The specific BMPs to be used for controlling sediment on this project include:

- **BMP C232: Gravel Filter Berm.** Gravel filter berms (or equivalent) will be installed along the perimeter of excavation and trenching areas to minimize sediment transport from the site.

Other sediment will be removed from paved areas in and adjacent to construction work areas manually or using mechanical sweepers, as needed, to minimize tracking of

sediments on vehicle tires away from the site and to minimize wash-off of sediments from adjacent streets in runoff.

Alternate BMPs for marking clearing limits are included in Appendix C as a quick reference tool for the on-site inspector in the event the BMP(s) listed above are deemed ineffective or inappropriate during construction. To avoid potential erosion and sediment control issues, the Certified Erosion and Sediment Control Lead will promptly initiate the implementation of one or more of the alternative BMPs listed in Appendix C after the first sign that existing BMPs are ineffective or failing.

3.1.5 Element #5 – Stabilize Soils

Exposed and unworked soils shall be stabilized with the application of effective BMPs to prevent erosion throughout the life of the project. The specific BMPs for soil stabilization that shall be used on this project include:

- **BMP C123: Plastic Covering.** Excavated upland material will be directly loaded into transport trucks whenever possible. Stockpiles that will be on site and unworked for longer than two days during the wet season (October 1 – April 30) or seven days during the dry season (May 1 – September 30) will be placed on and covered with impervious liner (plastic sheeting).
- **BMP C140: Dust Control.** Although dust is not anticipated since the site is entirely paved, water truck(s) will be made available to prevent fugitive dust from leaving the site. Water will be sprinkled to knock down dust but not so much as to create runoff.

Alternate BMPs for marking clearing limits are included in Appendix C as a quick reference tool for the on-site inspector in the event the BMP(s) listed above are deemed ineffective or inappropriate during construction. To avoid potential erosion and sediment control issues, the Certified Erosion and Sediment Control Lead will promptly initiate the implementation of one or more of the alternative BMPs listed in Appendix C after the first sign that existing BMPs are ineffective or failing.

In general, soil stockpiles will be temporarily covered with plastic sheeting. All stockpiled soils shall be stabilized from erosion, protected with sediment trapping measures, and where possible, be located away from storm drain inlets, waterways, and drainage channels.

3.1.6 Element #6 – Protect Slopes

Cut and fill slopes are not anticipated as part of this project. The only proposed slopes will derive from temporarily stockpiling soils. The following specific BMPs will be used to protect slopes for this project:

- **BMP C123: Plastic Sheeting.** Plastic sheeting will be used to protect any stockpiled soils from weather/erosion. No other slopes are located in the upland portion of the project area.

Alternate BMPs for marking clearing limits are included in Appendix C as a quick reference tool for the on-site inspector in the event the BMP(s) listed above are deemed ineffective or inappropriate during construction. To avoid potential erosion and sediment control issues, the Certified Erosion and Sediment Control Lead will promptly initiate the implementation of one or more of the alternative BMPs listed in Appendix C after the first sign that existing BMPs are ineffective or failing.

3.1.7 Element #7 – Protect Drain Inlets

All storm drain inlets made operable during construction shall be protected to prevent unfiltered or untreated water from entering the drainage conveyance system. However, the first priority is to keep all access roads clean of sediment and keep street wash water separate from entering storm drains until treatment can be provided. Storm Drain Inlet Protection (BMP C220) will be implemented for all drainage inlets that could potentially be impacted by sediment-laden runoff on and near the project site. The following inlet protection measures will be applied on this project:

- **BMP C220: Storm Drain Inlet Protection.** Storm drains located throughout the project area and adjacent to the project area will be protected.

Alternate BMPs for marking clearing limits are included in Appendix C as a quick reference tool for the on-site inspector in the event the BMP(s) listed above are deemed ineffective or inappropriate during construction. To avoid potential erosion and sediment control issues, the Certified Erosion and Sediment Control Lead will promptly initiate the implementation of one or more of the alternative BMPs listed in Appendix C after the first sign that existing BMPs are ineffective or failing.

3.1.8 Element #8 – Stabilize Channels and Outlets

Where site runoff is to be conveyed in channels, or discharged to a stream or some other natural drainage point, efforts will be taken to prevent downstream erosion.

- **BMP C209: Outlet Protection.** The outfall structure located within the project area will be demolished and the existing concrete outfall pipe will be stabilized at the dredge cutback slope. The outfall will be protected from any additional disturbance.

Alternate BMPs for marking clearing limits are included in Appendix C as a quick reference tool for the on-site inspector in the event the BMP(s) listed above are deemed ineffective or inappropriate during construction. To avoid potential erosion and sediment

control issues, the Certified Erosion and Sediment Control Lead will promptly initiate the implementation of one or more of the alternative BMPs listed in Appendix C after the first sign that existing BMPs are ineffective or failing.

3.1.9 Element #9 – Control Pollutants

All pollutants, including waste materials and demolition debris, that occur on site shall be handled and disposed of in a manner that does not cause contamination of stormwater. Good housekeeping and preventative measures will be taken to ensure that the site will be kept clean, well-organized, and free of debris. BMPs to be implemented to control specific sources of pollutants include:

- Vehicles, construction equipment, and/or petroleum storage/dispensing.
 - All vehicles, equipment, and petroleum storage/dispensing areas will be inspected regularly to detect any leaks or spills, and to identify maintenance needs to prevent leaks or spills.
 - On-site fueling tanks and petroleum product storage containers shall have secondary containment. Upland fueling operations will not occur within 50 feet of the shoreline.
 - Spill prevention measures, such as drip pans, will be used when conducting maintenance and repair of vehicles or equipment.
 - Emergency repairs on site will include placing plastic sheeting below and, if raining, above the vehicle.
 - If spills or leaks occur, surfaces that come into contact with the spilled material shall be cleaned immediately and disposed of properly.
 - A Spill Prevention, Control and Countermeasures (SPCC) Plan will be created and implemented to ensure proper response to potential environmental incidents.
 - **BMP C150: Materials On Hand and BMP C153: Material Delivery, Storage and Containment.**
- Debris and Waste Materials.
 - TBT-containing sediment shall be directly loaded onto a transport barge for removal from the site. Clean dredge

material will be disposed of at the open water Puget Sound Disposal Area.

- Demolition debris shall be segregated based on type and disposed of accordingly.
- Foundations and piles shall be dismantled and disposed of accordingly. Asphalt surfacing shall be replaced once demolition activities are complete and utilities are relocated. Appropriate pollution prevention measures will be implemented during these activities to ensure no concrete, slurry, asphalt, or other surfacing waste material enters surface waters.
- **BMP C123: Plastic Covering.**
- **BMP C151: Concrete Handling and BMP C152: Sawcutting and Surfacing Pollution Prevention.**

3.1.10 Element #10 – Control Dewatering

Dewatering and on-site treatment from the transload operations are covered under a separate document.

3.1.11 Element #11 – Maintain BMPs

All temporary and permanent erosion and sediment control BMPs shall be maintained and repaired as needed to assure continued performance of their intended function. Maintenance and repair shall be conducted in accordance with each particular BMPs specifications (attached). Visual monitoring of the BMPs will be conducted at least once every calendar week and within 24 hours of any stormwater or non-stormwater discharge from the site. If the site becomes inactive, and is temporarily stabilized, the inspection frequency will be reduced to once every month.

A CESCL (**BMP C160**) will conduct the ESC site inspections and be on site or on-call at all times during construction activity.

All temporary erosion and sediment control BMPs shall be removed within 30 days after the final site stabilization is achieved or after the temporary BMPs are no longer needed. Trapped sediment shall be removed or stabilized on site. Disturbed soil resulting from removal of BMPs or vegetation shall be permanently stabilized.

3.1.12 Element #12 – Manage the Project

Erosion and sediment control BMPs for this project have been designed based on the following principles:

- Design the project to fit the existing topography, soils, and drainage patterns.
- Emphasize erosion control rather than sediment control.
- Minimize the extent and duration of the area exposed.
- Keep runoff velocities low.
- Retain sediment on site.
- Thoroughly monitor site and maintain all ESC measures.
- Schedule major earthwork during the dry season, if possible.

In addition, project management will incorporate the key components listed below:

As this project site is located west of the Cascade Mountain Crest, the project will be managed according to the following key project components:

Phasing of Construction

- The construction project will be phased as needed in order to prevent soil erosion, and, to the maximum extent possible, the transport of sediment from the site during construction. Areas that have undergone remediation and/or demolition will be stabilized to the maximum extent practicable.

Seasonal Work Limitations

- From October 1 through April 30, clearing, grading, and other soil disturbing activities shall only be permitted if shown to the satisfaction of the local permitting authority that silt-laden runoff will be prevented from leaving the site through a combination of the following:
 - Site conditions including existing vegetative coverage, slope, soil type, and proximity to receiving waters; and
 - Limitations on activities and the extent of disturbed areas; and
 - Proposed erosion and sediment control measures.

- Based on the information provided and/or local weather conditions, the local permitting authority may expand or restrict the seasonal limitation on site disturbance.
- The following activities are exempt from the seasonal clearing and grading limitations:
 - Routine maintenance and necessary repair of erosion and sediment control BMPs;
 - Routine maintenance of public facilities or existing utility structures that do not expose the soil or result in the removal of the vegetative cover to soil; and
 - Activities where there is 100 percent infiltration of surface water runoff within the site in approved and installed erosion and sediment control facilities.

Coordination with Utilities and Other Jurisdictions

- Care has been taken to coordinate with utilities, other construction projects, and the local jurisdiction in preparing this SWPPP and scheduling the construction work.

Inspection and Monitoring

- All BMPs shall be inspected, maintained, and repaired as needed to assure continued performance of their intended function. Site inspections shall be conducted by a person who is knowledgeable in the principles and practices of erosion and sediment control. This person has the necessary skills to:
 - Assess the site conditions and construction activities that could impact the quality of stormwater, and
 - Assess the effectiveness of erosion and sediment control measures used to control the quality of stormwater discharges.
- A CESCL shall be on site or on-call at all times.
- Whenever inspection and/or monitoring reveals that the BMPs identified in this SWPPP are inadequate, due to the actual discharge of or potential to discharge a significant amount of any pollutant,

appropriate BMPs or design changes shall be implemented as soon as possible.

Maintaining an Updated Construction SWPPP

- This SWPPP shall be retained on site or within reasonable access to the site.
- The SWPPP shall be modified whenever there is a change in the design, construction, operation, or maintenance at the construction site that has, or could have, a significant effect on the discharge of pollutants to waters of the state.
- The SWPPP shall be modified if it is determined that the SWPPP is ineffective in eliminating or significantly minimizing pollutants in stormwater discharges from the site. The SWPPP shall be modified as necessary to include additional or modified BMPs designed to correct problems identified. Revisions to the SWPPP shall be completed within seven (7) days following the inspection.

4.0 Construction Phasing and BMP Implementation

The BMP implementation schedule is driven by the construction schedule. The following provides a sequential list of the proposed construction schedule milestones and the corresponding BMP implementation schedule. The list contains key milestones such as wet season construction.

BMP implementation schedule listed below is keyed to proposed phases of the construction project, and reflects differences in BMP installations and inspections that relate to wet season construction. The project site is located west of the Cascade Mountain Crest. As such, the dry season is considered to be May 1 – September 30 and the wet season is considered to be October 1 – April 30.

- | | |
|---|-----------------------|
| ▪ Wet Season starts: | 10 / 01 / 2014 |
| ▪ Estimate of Construction Start Date: | 03 / 01 / 2015 |
| ▪ Estimate of Construction Finish Date: | 02 / 29 / 2016 |

- Mobilize equipment on site: 04 / 09 / 2015
- Mobilize and store all ESC and soil stabilization products (store Materials On Hand BMP C150): 04 / 09 / 2015
- Install ESC measures: 04 / 13 / 2015
- Site inspections and monitoring conducted weekly and for applicable rain events as detailed in Section 6 of this SWPPP: 04 / 20 / 2015
- **Dry Season starts:** **05 / 01 / 2015**
- Begin utility and deck demolition: 05 / 09 / 2015
- Deck demolition complete: 08 / 16 / 2015
- Permanent ESC measures (gravel surfacing) begins: 08 / 16 / 2015

5.0 Pollution Prevention Team

5.1 Roles and Responsibilities

The pollution prevention team consists of personnel responsible for implementation of the SWPPP, including the following:

- CESCL (CESCL) – primary contractor contact, responsible for site inspections (BMPs, visual monitoring, sampling, etc.); to be called upon in case of failure of any ESC measures.
- Resident Engineer – for projects with engineered structures only (sediment ponds/traps, sand filters, etc.): site representative for the owner that is the project's supervising engineer responsible for inspections and issuing instructions and drawings to the contractor's site supervisor or representative
- Emergency Owner Contact – individual that is the site owner or representative of the site owner to be contacted in the case of an emergency.
- Monitoring Personnel – personnel responsible for conducting water quality monitoring; for most sites this person is also the CESCL.

5.2 Team Members

Names and contact information for those identified as members of the pollution prevention team are provided in the following table.

Title	Name(s)	Phone Number
Certified Erosion and Sediment Control Lead (CESCL)		
Port Project Manager	Stan Ryter	253.830.5315
Emergency Owner Contact	Port Security	253.383.9472
Emergency Ecology Contact	Southwest Regional Office	360.407.6300
Monitoring Personnel		

6.0 Site Inspections and Monitoring

Monitoring includes visual inspection, monitoring for water quality parameters of concern and documentation of the inspection and monitoring findings in a site log book. A site log book will be maintained for all on-site construction activities and will include:

- A record of the implementation of the SWPPP and other permit requirements;
- Site inspections; and,
- Stormwater quality monitoring.

For convenience, the inspection form and water quality monitoring forms included in this SWPPP include the required information for the site log book. This SWPPP may function as the site log book if desired, or the forms may be separated and included in a separate site log book. However, if separated, the site log book must be maintained on site or within reasonable access to the site and be made available upon request to Ecology or the local jurisdiction.

6.1 Site Inspection

All BMPs will be inspected, maintained, and repaired as needed to assure continued performance of their intended function. The inspector will be a CESCL per BMP C160. The name and contact information for the CESCL is provided in Section 5 of this SWPPP.

Site inspection will occur in all areas disturbed by construction activities and at all potential stormwater discharge points. Stormwater will be examined for the presence of suspended sediment, turbidity, discoloration, and oily sheen.

The site inspector will evaluate and document the effectiveness of the installed BMPs and determine if it is necessary to repair or replace any of the BMPs to improve the quality of stormwater discharges. All maintenance and repairs will be documented in the site log book or forms provided in this document. All new BMPs or design changes will be documented in the SWPPP as soon as possible.

6.1.1 Site Inspection Frequency

Site inspections will be conducted at least once a week and within 24 hours following any discharge from the site. For sites with temporary stabilization measures, the site inspection frequency will be reduced to once every month.

6.1.2 Site Inspection Documentation

The site inspector will record each site inspection using the site log inspection forms provided in Appendix D. The site inspection log forms may be separated from this SWPPP document, but will be maintained on site or within reasonable access to the site and be made available upon request to Ecology or the local jurisdiction.

6.2 Stormwater Quality Monitoring

6.2.1 Turbidity

Turbidity sampling and monitoring will be conducted during the entire construction phase of the project. Samples will be collected weekly at the discharge point nearest the current phase of the project work. If there is no flow at the discharge point, the attempt to sample will be recorded in the site log book and reported to the Port as “No Discharge”. Discharge reports will be submitted to the Port on a monthly basis. **Samples will be analyzed for turbidity using the Hach 2100Q Turbidimeter.**

The key benchmark turbidity value is 25 nephelometric turbidity units (NTU) for the downstream receiving water body. If the 25 NTU benchmark is exceeded in any sample collected, the following steps will be conducted:

1. Ensure all BMPs specified in this SWPPP are installed and functioning as intended.
2. Assess whether additional BMPs should be implemented, and document modified BMPs in the SWPPP as necessary.
3. Sample discharge daily until the discharge is 25 NTU or lower.

If the turbidity exceeds 250 NTU at any time, the following steps will be conducted:

1. Notify Ecology by phone within 24 hours of analysis (see Section 5.0 of this SWPPP for contact information).
2. Continue sampling daily until the discharge is 25 NTU or lower. Initiate additional treatment BMPs such as off-site treatment, infiltration, filtration and chemical treatment within 24 hours, and implement those additional treatment BMPs as soon as possible, but within a minimum of 7 days.
3. Describe inspection results and remedial actions taken in the site log book and in monthly discharge monitoring reports as described in Section 7.0 of this SWPPP.

6.2.2 pH

Sampling and monitoring for pH occurs if significant concrete work (>1,000 cubic yards poured throughout the life of the project) or use of engineered soils (e.g., cement-treated base) is anticipated. No significant concrete work or engineered soils are planned for this project; therefore, no pH testing will be performed.

7.0 Reporting and Recordkeeping

7.1 Recordkeeping

7.1.1 Site Log Book

A site log book will be maintained for all on-site construction activities and will include:

- A record of the implementation of the SWPPP and other permit requirements;
- Site inspections; and,
- Stormwater quality monitoring.

For convenience, the inspection form and water quality monitoring forms included in this SWPPP include the required information for the site log book.

7.1.2 Records Retention

Records of all monitoring information (site log book, inspection reports/checklists, etc.), this SWPPP, and any other documentation of compliance with permit requirements will be retained during the life of the construction project and for a minimum of three years.

7.1.3 Access to Plans and Records

The SWPPP and Site Log Book will be retained on site or within reasonable access to the site and will be made immediately available upon request to Ecology or the local jurisdiction. A copy of this SWPPP will be provided to Ecology within 14 days of receipt of a written request for the SWPPP from Ecology. Any other information requested by Ecology will be submitted within a reasonable time. A copy of the SWPPP or access to the SWPPP will be provided to the public when requested in writing.

7.1.4 Updating the SWPPP

This SWPPP will be modified if the SWPPP is ineffective in eliminating or significantly minimizing pollutants in stormwater discharges from the site or there has been a change in design, construction, operation, or maintenance at the site that has a significant effect on the discharge, or potential for discharge, of pollutants to the waters of the State. The SWPPP will be modified within seven (7) days of determination based on inspection(s) that additional or modified BMPs are necessary to correct problems identified, and an updated timeline for BMP implementation will be prepared.

7.2 Reporting

7.2.1 Discharge Monitoring Reports

Stormwater discharge reports will be submitted to the Port monthly. If there was no discharge during a given monitoring period, the Contractor shall submit the form as required, with the words "No Discharge" entered in the place of the monitoring results. The discharge report due date is 15 days following the end of each month.

7.2.2 Notification of Noncompliance

If any of the terms and conditions of the permit is not met, and it causes a threat to human health or the environment, the following steps will be taken in accordance with permit section S5.F:

1. Ecology will be immediately notified of the failure to comply.
2. Immediate action will be taken to control the noncompliance issue and to correct the problem. If applicable, sampling and analysis of any noncompliance will be repeated immediately and submitted to Ecology within five days of becoming aware of the violation.
3. A detailed report describing the noncompliance will be submitted to Ecology within five days, unless requested earlier by Ecology.

Appendix A – Site Plans

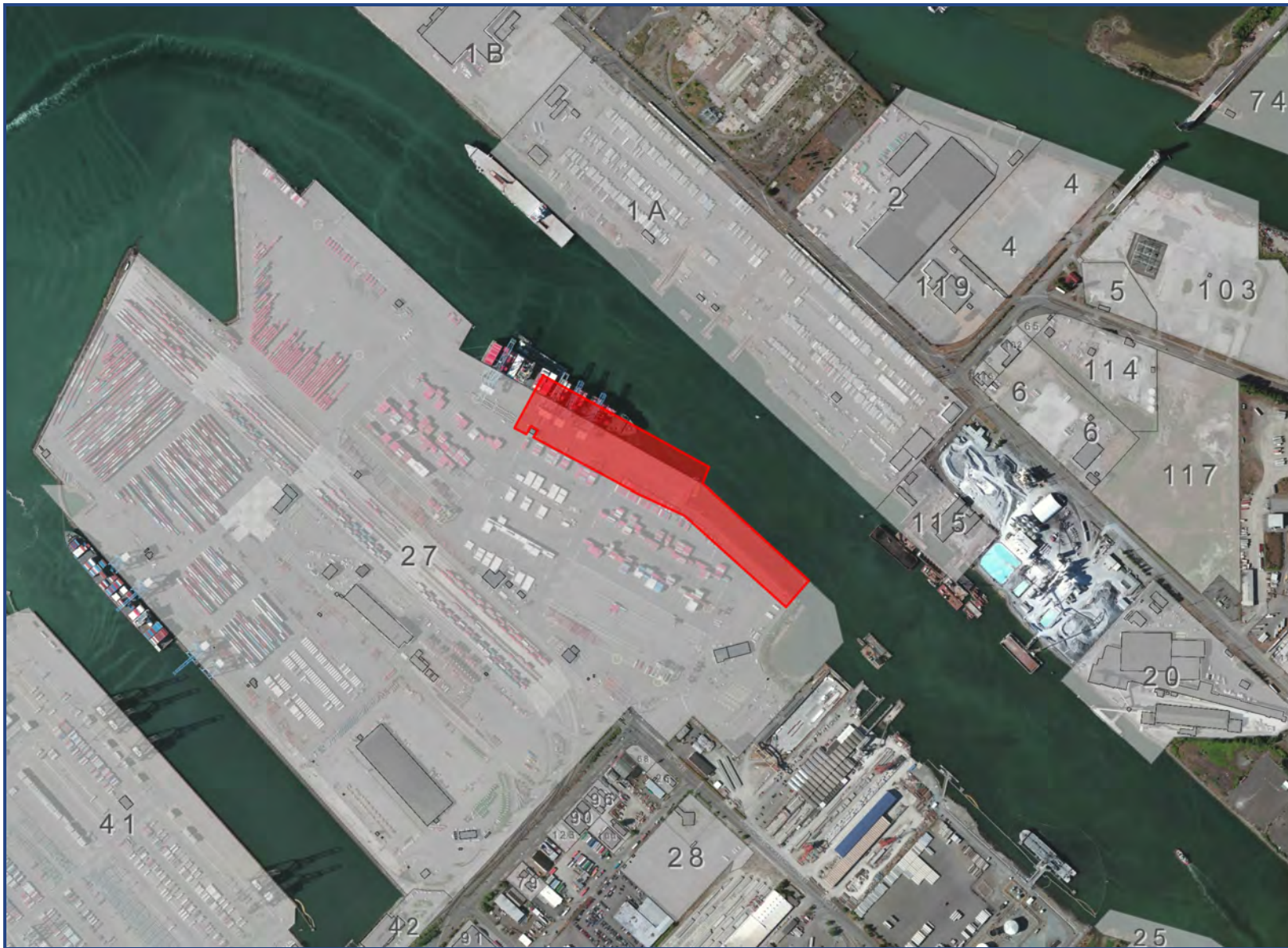

Legend

- Building Footprints
- Port Parcels

Notes

SCALE 1: 15,000



DISCLAIMER: The information included on this map has been compiled by Port of Tacoma staff from a variety of sources and is subject to change without notice. These data are intended for informational purposes and should not be considered authoritative for engineering, navigational, legal and other site-specific uses. The Port of Tacoma makes no representations or warranties, express or implied, as to accuracy, completeness, timeliness, or rights to the use of such information.

2407 North 31st Street, Suite 100
Tacoma, Washington 98407
(253) 396-0150 Fax (253) 396-0162

TESC NOTES:

1. APPROVAL OF THIS TEMPORARY EROSION CONTROL (TESC) PLAN DOES NOT CONSTITUTE AN APPROVAL OF DRAINAGE DESIGN (E.G. SIZE AND LOCATION OF PIPES, STRUCTURES, ETC.) OR THE CONTRACTOR MAINTAINED CONSTRUCTION STORM WATER POLLUTION PREVENTION PLAN (SWPPP).
2. THE CONTRACTOR SHALL COMPLY WITH, MAINTAIN, AND MODIFY AS NEEDED THE APPROVED CONSTRUCTION SWPPP IN ACCORDANCE WITH THE CONTRACT DOCUMENTS.
3. THE IMPLEMENTATION OF THESE TESC PLANS AND CONSTRUCTION, MAINTENANCE, REPLACEMENT AND UPGRADING OF THESE FACILITIES IS THE RESPONSIBILITY OF THE CONTRACTOR UNTIL ALL CONSTRUCTION IS COMPLETED AND APPROVED.
4. THE TESC FACILITIES SHOWN ON THIS PLAN ARE THE MINIMUM REQUIREMENTS ANTICIPATED FOR SITE CONDITIONS. DURING THE CONSTRUCTION PERIOD, THESE TESC FACILITIES SHALL BE UPGRADED AS NEEDED FOR UNEXPECTED STORM EVENTS AND TO ENSURE THAT SEDIMENT AND SEDIMENT-LADEN WATER DOES NOT LEAVE THE SITE.
5. ON-SITE EROSION CONTROL MEASURES SHALL BE INSTALLED PRIOR TO THE START OF WORK AND SHALL BE MAINTAINED DURING AND AFTER EXCAVATION AND GRADING OPERATIONS TO THE APPROVAL OF THE PORT.
6. IF CONSTRUCTION OCCURS DURING DRY WEATHER PERIODS, DUST FROM CONSTRUCTION SHALL BE MINIMIZED THROUGH USE OF BEST MANAGEMENT PRACTICES (BMPs) OUTLINED IN THE SWPPP AND THE CITY'S STORMWATER MANUAL.
7. THE TESC FACILITIES SHOWN ON THIS PLAN SHALL BE CONSTRUCTED IN SUCH A MANNER AS TO ENSURE THAT SEDIMENT-LADEN WATER DOES NOT ENTER THE PORT DRAINAGE SYSTEM, THE BLAIR WATERWAY, OR VIOLATE APPLICABLE WATER QUALITY STANDARDS
8. THE TESC FACILITIES SHALL BE INSPECTED DAILY BY THE CONTRACTOR AND MAINTAINED AS NECESSARY TO ENSURE THEIR CONTINUED FUNCTION. DAILY INSPECTION REPORTS MUST BE REVIEWED BY THE CONTRACTOR, SIGNED AND MADE AVAILABLE TO THE PORT, CITY AND ANY OTHER ENVIRONMENTAL AUTHORITIES AT ALL TIMES. A COPY OF ALL INSPECTION RECORDS SHALL BE KEPT ON SITE.
9. ALL FACILITIES SHALL BE MAINTAINED ON SITE BY SWEEPING TO PREVENT DEBRIS, DUST AND MUD FROM ACCUMULATING ON THE PAVED SURFACES, BANK SLOPE, OR IN THE BLAIR WATERWAY, SITCUM WATERWAY, AND COMMENCEMENT BAY.
10. NON-COMPLIANCE WITH THE EROSION CONTROL AND WATER QUALITY REQUIREMENTS MAY RESULT IN A TEMPORARY STOP-WORK ORDER AT THE CONTRACTORS EXPENSE, UNTIL SAID EROSION CONTROL MEASURES ARE FUNCTIONAL.
11. THE CONTRACTOR SHALL REMOVE MATERIAL DROPPED, WASHED OR TRACKED FROM VEHICLES OUTSIDE OF THE DESIGNATED PROJECT WORK AREA LIMITS OR INTO THE EXISTING STORM DRAINAGE SYSTEM. DEBRIS SHALL NOT BE WASHED INTO THE STORM DRAINAGE SYSTEM, ONTO THE BANK SLOPE, OR INTO THE BLAIR WATERWAY, SITCUM WATERWAY, AND COMMENCEMENT BAY.
12. DEWATERING ACTIVITIES SHALL BE PERFORMED IN A MANNER THAT ENSURES NO SILT-LADEN WATER ENTERS THE BLAIR WATERWAY, SITCUM WATERWAY, COMMENCEMENT BAY, OR STORM DRAINAGE SYSTEM.
13. ALL CATCH BASIN INLET PROTECTION INSTALLED SHALL BE REPLACED AND LEFT IN PLACE AT THE END OF CONSTRUCTION, AFTER FINAL INSPECTION AND ACCEPTANCE.
14. REMOVE SEDIMENT FROM THE STORM SYSTEM ONCE THE SITE IS PERMANENTLY STABILIZED. THE CLEANING AND REMOVAL OPERATION SHALL NOT FLUSH SEDIMENT DOWNSTREAM.
15. COORDINATE TESC PROVISION THAT ARE OUTSIDE OF THE PROJECT WORK AREA WITH THE ENGINEER AND PORT.
16. THE CONTRACTOR SHALL REMOVE MATERIAL AND/OR DEBRIS FROM VEHICLES EXITING THE PROJECT LIMITS, BUT NOT WASH THE DEBRIS INTO THE EXISTING STORM DRAINAGE SYSTEM.
17. IN ADDITION TO INLET PROTECTION SHOWN ON PLAN, CONTRACTOR SHALL INSTALL AND MAINTAIN INLET PROTECTION ON ALL EXISTING CATCH BASINS THAT ARE DISCOVERED IN FIELD WITHIN THE PROJECT WORK AREA LIMITS.
18. THE TEMPORARY FLOATING DEBRIS BOOM SHALL BE INSTALLED AT THE START OF WORK AND MAINTAINED, UPGRADED, REPAIRED OR REPLACED THE ENTIRE CONSTRUCTION PERIOD UNTIL ALL CONSTRUCTION IS COMPLETED AND APPROVED.

G8.1	PIER 4 PHASE 1 REMOVAL ACTION PROJECT TESC GENERAL NOTES	APPROVED:	
CONT/CONS: 069982	TOWNSHIP: SECTION:	CHECKED BY:	DATE:
M. ID: 091452	RANGE: MLLW 19.39 @ Tide 22 1933	PROJECT ENGR:	DATE:
PHASE: 90%	VERT: WA83-SF	PRINTED BY: kvong	Jan 23, 2015
	PARCEL: DRAWING SCALE: AS NOTED	PORT ADDRESS: ONE SITCUM PLAZA	TACOMA, WA 98401-1837



2407 North 31st Street, Suite 100
Tacoma, Washington 98407
(253) 396-0150 Fax (253) 396-0162



Port of Tacoma
P.O. BOX 1837 TACOMA, WA 98401 (253)396-3441



BLAIR WATERWAY

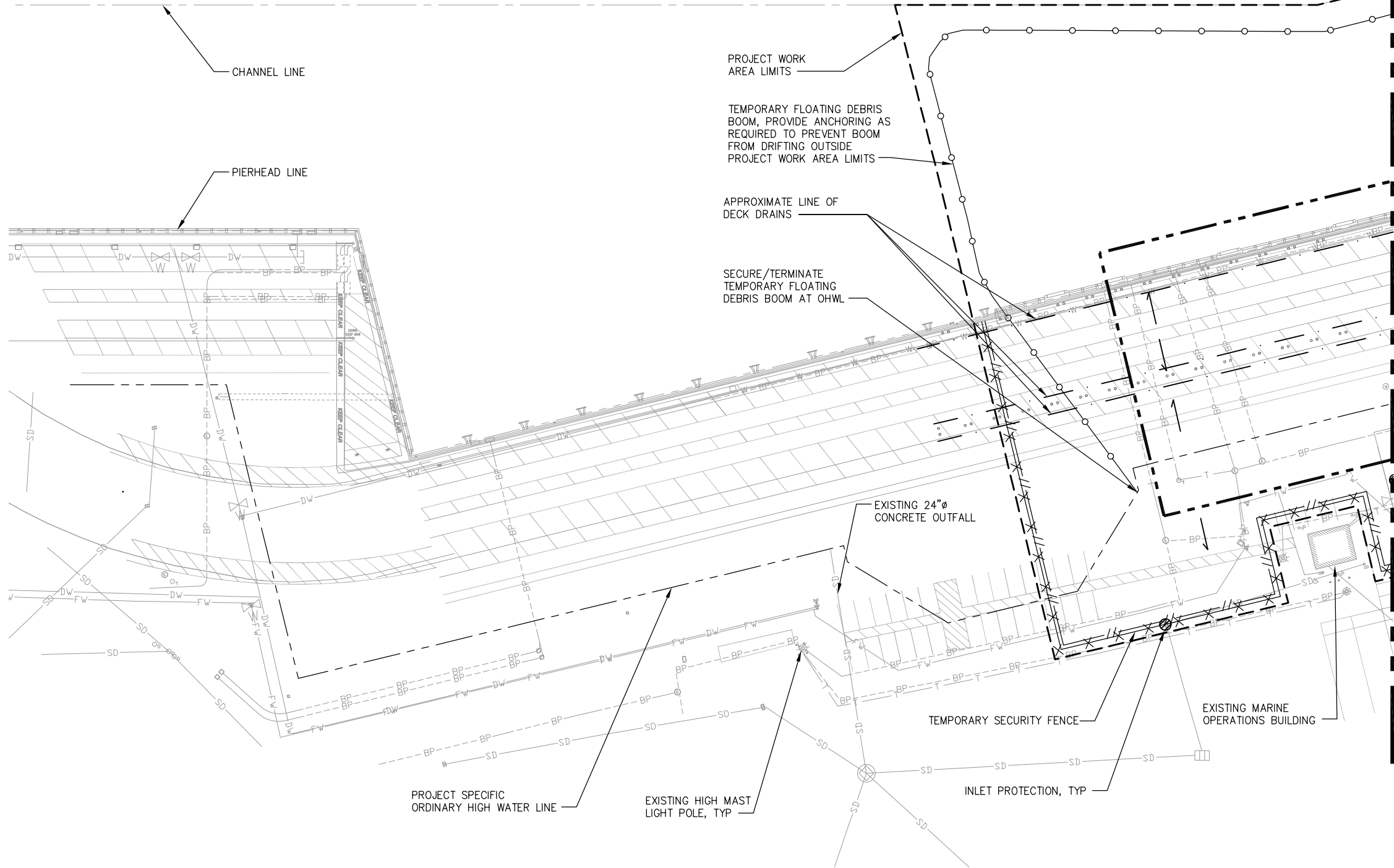

TESC PLAN
SCALE: 1"=40'

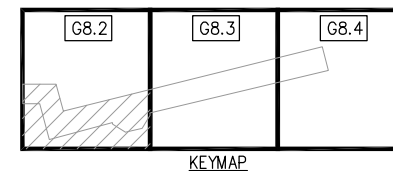

TESC NOTES

1. SEE SHEET G8.1 FOR TESC NOTES.
2. SEE SHEET G6.1 FOR TEMPORARY SECURITY FENCE LOCATION.

LEGEND

- PROJECT WORK AREA LIMITS
- - - DEMOLITION LIMIT LINE, SEE DEMOLITION PLANS
- × × TEMPORARY SECURITY FENCE ON CONCRETE TRAFFIC BARRIERS
- ⊗ INLET PROTECTION, (1) G8.5
- ○ TEMPORARY FLOATING DEBRIS BOOM
- // TEMPORARY SEDIMENT BARRIER (2) G8.5
- - - PROJECT SPECIFIC ORDINARY HIGH WATER LINE
- - - APPROXIMATE LINE OF DECK DRAINS
- GENERAL DIRECTION OF SURFACE FLOW

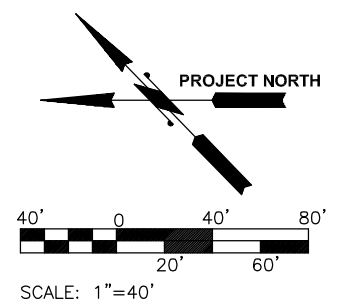

MATCH LINE SEE SHEET G8.3

Port of Tacoma
P.O. BOX 1837 TACOMA, WA 98401 (206)383-3441

kpff
2407 North 31st Street, Suite 100
Tacoma, Washington 98407
(253) 396-0150 Fax (253) 396-0162

PROVISIONAL

APPROVED:	CHECKED BY:	DATE:
DIRECTOR ENG. DATE:	PROJ. ENGR.	DATE:
PRINTED BY: enielsen	Jan 23, 2015	
PORT ADDRESS: ONE SITCUM PLAZA		
TACOMA, WA 98401-1837		

PIER 4 PHASE 1	TOWNSHIP:	SECTION:	RANGE:
REMOVAL ACTION PROJECT	DATE-HRZ: WA83-SF	DATE: MLLW 19.39 @ Tide 22 1933	VERT: MLLW 19.39 @ Tide 22 1933
TESC PLAN - SHEET 1	PARCEL:	DRAWING SCALE: AS NOTED	

G8.2	SH #	OF #
069982	069982	
091452	091452	
90%	90%	

90% SUBMITTAL - NOT FOR CONSTRUCTION

THIS DRAWING IS THE PROPERTY OF THE PORT OF TACOMA AND SHALL NOT BE USED ON OTHER WORK, DISCLOSED, COPIED, IN WHOLE OR IN PART, WITHOUT WRITTEN PERMISSION

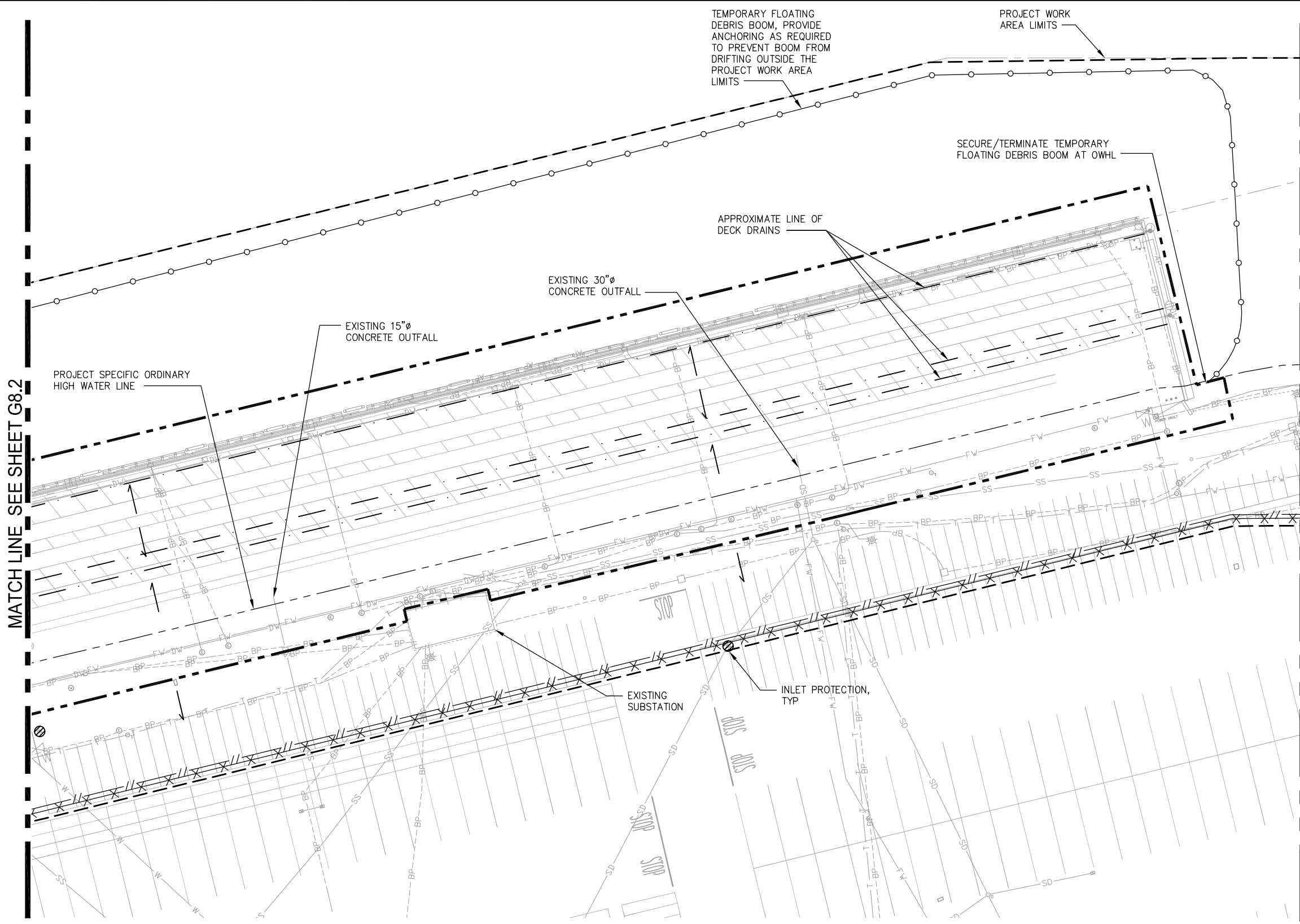

TESC NOTES

- SEE SHEET G8.1 FOR TESC NOTES.
- SEE SHEET G6.1 FOR TEMPORARY SECURITY FENCE LOCATION.

LEGEND

- PROJECT WORK AREA LIMITS
- DEMOLITION LIMIT LINE, SEE DEMOLITION PLANS
- TEMPORARY SECURITY FENCE ON CONCRETE TRAFFIC BARRIERS
- INLET PROTECTION, (1) G8.5
- TEMPORARY FLOATING DEBRIS BOOM
- TEMPORARY SEDIMENT BARRIER (2) G8.5
- PROJECT SPECIFIC ORDINARY HIGH WATER LINE
- APPROXIMATE LINE OF DECK DRAINS
- GENERAL DIRECTION OF SURFACE FLOW

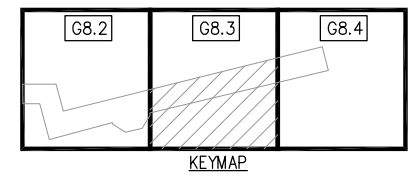
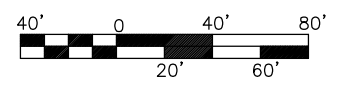
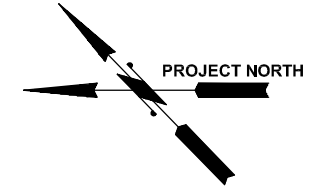

TESC PLAN

SCALE: 1"=40'

Part of Tacoma
P.O. BOX 1837 TACOMA, WA 98401 (203)3834841

2407 North 31st Street, Suite 100
Tacoma, Washington 98407
(253) 396-0150 Fax (253) 396-0162

DATE: _____

APPR: _____

BY: _____

REVISION: _____

MARK: _____

APPROVED:

CHECKED BY	DATE	DIRECTOR ENGR. DATE	PROJ. ENGR. DATE
		enijensen	Jan 23, 2015
PRINTED BY:		PORT ADDRESS: ONE SITCUM PLAZA	
		TACOMA, WA 98401-1837	

PIER 4 PHASE 1
REMOVAL ACTION PROJECT
TESC PLAN - SHEET 2

TOWNSHIP:	SECTION:	RANGE:	DATE:
		MLLW 19.39 @ Tide 22 1933	091452
PARCEL:		DRAWING SCALE: AS NOTED	

G8.3

SH# OF #

CONT/CONS: 069982

M. ID: 091452

PHASE: 90%

THIS DRAWING IS THE PROPERTY OF THE PORT OF TACOMA AND SHALL NOT BE USED ON OTHER WORK, DISCLOSED, COPIED, IN WHOLE OR IN PART, WITHOUT WRITTEN PERMISSION

90% SUBMITTAL - NOT FOR CONSTRUCTION

MATCH LINE SEE SHEET G8.3

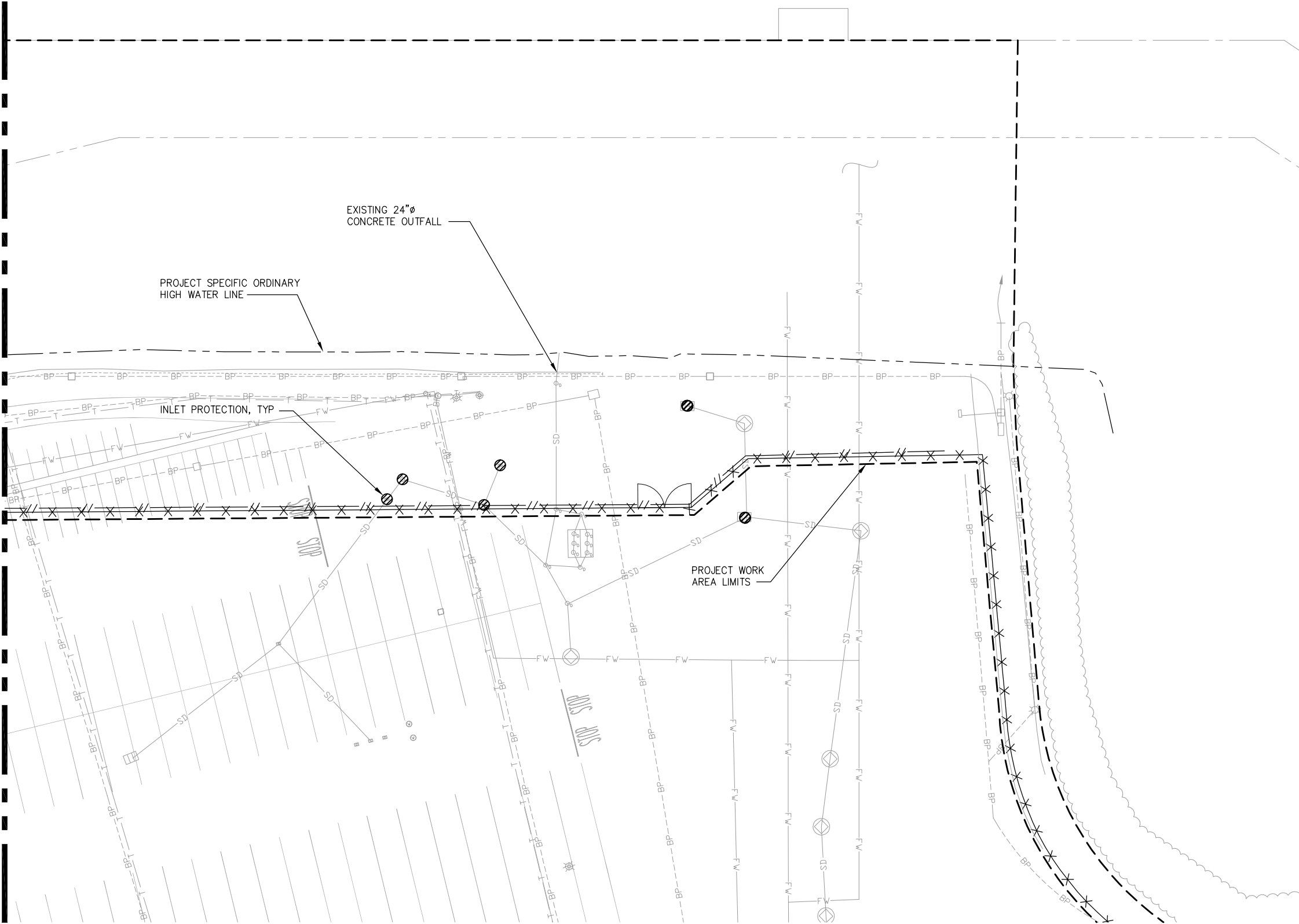

TESC PLAN
SCALE: 1"=40'

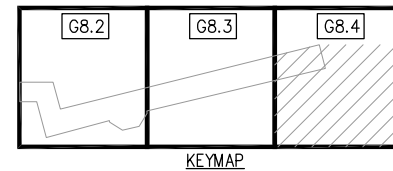

TESC NOTES

- SEE SHEET G8.1 FOR TESC NOTES.
- SEE SHEET G6.1 FOR TEMPORARY SECURITY FENCE LOCATION.

LEGEND

- PROJECT WORK AREA LIMITS
- - - DEMOLITION LIMIT LINE, SEE DEMOLITION PLANS
- X X TEMPORARY SECURITY FENCE ON CONCRETE TRAFFIC BARRIERS
- ⊙ INLET PROTECTION, (1) G8.5
- ○ TEMPORARY FLOATING DEBRIS BOOM
- // TEMPORARY SEDIMENT BARRIER (2) G8.5
- - - PROJECT SPECIFIC ORDINARY HIGH WATER LINE
- - - APPROXIMATE LINE OF DECK DRAINS
- GENERAL DIRECTION OF SURFACE FLOW

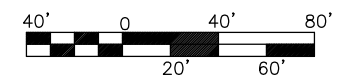
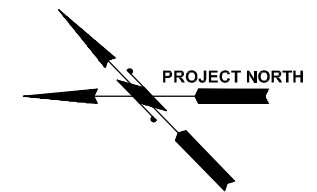

SCALE: 1"=40'

90% SUBMITTAL - NOT FOR CONSTRUCTION



kpff
 2407 North 31st Street, Suite 100
 Tacoma, Washington 98407
 (253) 396-0150 Fax (253) 396-0162

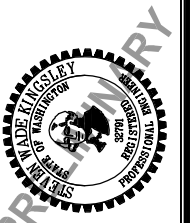

APPROVED:	CHECKED BY:	DATE:
DIRECTOR ENGR. DATE:	PROJ. ENGR. DATE:	
PRINTED BY: enielsen	Jan 23, 2015	
PORT ADDRESS: ONE SITCUM PLAZA		
TACOMA, WA 98401-1837		

PIER 4 PHASE 1
REMOVAL ACTION PROJECT
 TESC PLAN - SHEET 3

G8.4
 SH# OF #
 CONT/CONS: 069982
 M. ID: 091452
 PHASE: 90%

THIS DRAWING IS THE PROPERTY OF THE PORT OF TACOMA AND SHALL NOT BE USED ON OTHER WORK, DISCLOSED, COPIED, IN WHOLE OR IN PART, WITHOUT WRITTEN PERMISSION

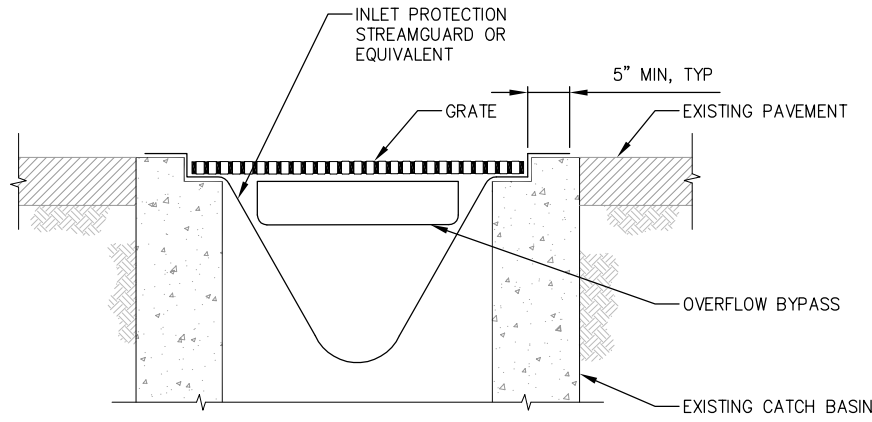

MAINTENANCE STANDARDS:

1. ANY ACCUMULATED SEDIMENT ON OR AROUND THE FILTER FABRIC SHALL BE REMOVED IMMEDIATELY. SEDIMENT SHALL NOT BE REMOVED BY FLUSHING. ALL SEDIMENT MUST BE DISPOSED OF OFF-SITE.
2. ANY SEDIMENT IN THE CATCH BASIN INSERT SHALL BE REMOVED WHEN SEDIMENT HAS FILLED ONE-THIRD OF THE AVAILABLE STORAGE. THE FILTER MEDIA FOR THE INSERT SHALL BE CLEANED OR REPLACED AT LEAST MONTHLY, OR AS DIRECTED BY THE ENGINEER.

CATCH BASIN INLET PROTECTION

1
G8.2, G8.3, G8.4 NTS

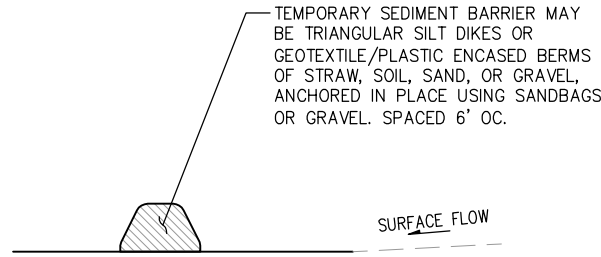

TEMPORARY SEDIMENT BARRIER

2
G8.2, G8.3, G8.4 NTS

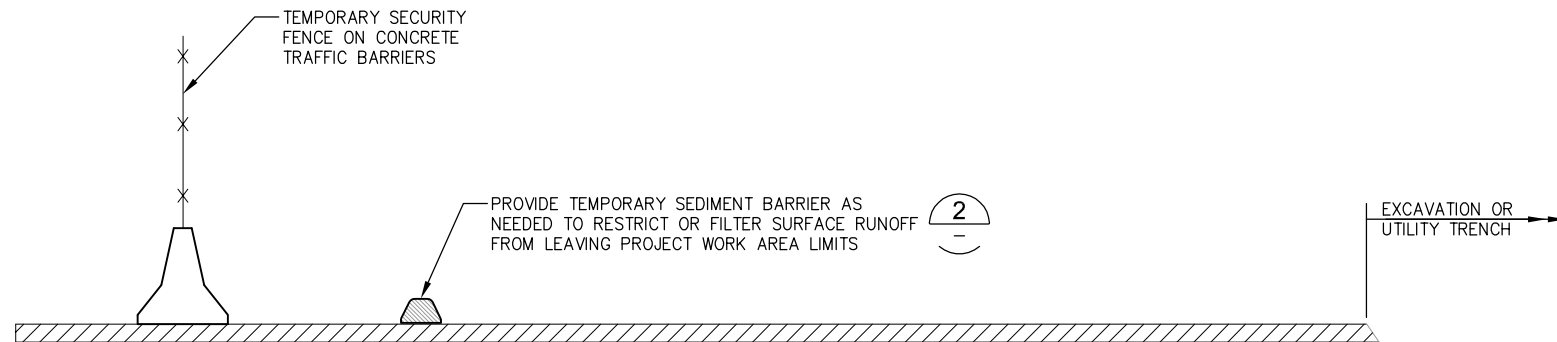

DETAIL-TYP EXCAVATION SECTION

3
G8.2, G8.3, G8.4 NTS

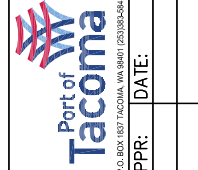

kpff
 2407 North 31st Street, Suite 100
 Tacoma, Washington 98407
 (253) 396-0150 Fax (253) 396-0162



APPROVED:	CHECKED BY:	DATE:
DIRECTOR ENGR. DATE:	PROJ. ENGR. DATE:	
PRINTED BY: kwang	Jan 23, 2015	
PORT ADDRESS: ONE SITCUM PLAZA	TACOMA, WA 98401-1837	

G8.5 SH # OF #	CONT/CONS: 069982	TOWNSHIP: SECTION:	RANGE: MLLW 19.39 @ Tide 22 1933
	M. ID: 091452	DATE-HRZ: WA83-SF	VERT: TIDE 22 1933
	PHASE: 90%	PARCEL:	DRAWING SCALE: AS NOTED
	PIER 4 PHASE 1 REMOVAL ACTION PROJECT TESC DETAILS		

MARK:	REVISION:	BY:	DATE:

THIS DRAWING IS THE PROPERTY OF THE PORT OF TACOMA AND SHALL NOT BE USED ON OTHER WORK, DISCLOSED, COPIED, IN WHOLE OR IN PART, WITHOUT WRITTEN PERMISSION

Appendix B – Construction BMPs

BMP C103: High Visibility Fence

<i>Purpose</i>	Fencing is intended to: <ol style="list-style-type: none">1. Restrict clearing to approved limits.2. Prevent disturbance of sensitive areas, their buffers, and other areas required to be left undisturbed.3. Limit construction traffic to designated construction entrances, exits, or internal roads.4. Protect areas where marking with survey tape may not provide adequate protection.
<i>Conditions of Use</i>	To establish clearing limits plastic, fabric, or metal fence may be used: <ul style="list-style-type: none">• At the boundary of sensitive areas, their buffers, and other areas required to be left uncleared.• As necessary to control vehicle access to and on the site.
<i>Design and Installation Specifications</i>	<p>High visibility plastic fence shall be composed of a high-density polyethylene material and shall be at least four feet in height. Posts for the fencing shall be steel or wood and placed every 6 feet on center (maximum) or as needed to ensure rigidity. The fencing shall be fastened to the post every six inches with a polyethylene tie. On long continuous lengths of fencing, a tension wire or rope shall be used as a top stringer to prevent sagging between posts. The fence color shall be high visibility orange. The fence tensile strength shall be 360 lbs./ft. using the ASTM D4595 testing method.</p> <p>If appropriate install fabric silt fence in accordance with BMP C233 to act as high visibility fence. Silt fence shall be at least 3 feet high and must be highly visible to meet the requirements of this BMP.</p> <p>Metal fences shall be designed and installed according to the manufacturer's specifications.</p> <p>Metal fences shall be at least 3 feet high and must be highly visible.</p> <p>Fences shall not be wired or stapled to trees.</p>
<i>Maintenance Standards</i>	If the fence has been damaged or visibility reduced, it shall be repaired or replaced immediately and visibility restored.

BMP C105: Stabilized Construction Entrance / Exit

Purpose Stabilized Construction entrances are established to reduce the amount of sediment transported onto paved roads by vehicles or equipment. This is done by constructing a stabilized pad of quarry spalls at entrances and exits for construction sites.

Conditions of Use Construction entrances shall be stabilized wherever traffic will be entering or leaving a construction site if paved roads or other paved areas are within 1,000 feet of the site.

For residential construction provide stabilized construction entrances for each residence, rather than only at the main subdivision entrance. Stabilized surfaces shall be of sufficient length/width to provide vehicle access/parking, based on lot size/configuration.

On large commercial, highway, and road projects, the designer should include enough extra materials in the contract to allow for additional stabilized entrances not shown in the initial Construction SWPPP. It is difficult to determine exactly where access to these projects will take place; additional materials will enable the contractor to install them where needed.

Design and Installation Specifications

See [Figure 4.1.1](#) for details. Note: the 100' minimum length of the entrance shall be reduced to the maximum practicable size when the size or configuration of the site does not allow the full length (100').

Construct stabilized construction entrances with a 12-inch thick pad of 4-inch to 8-inch quarry spalls, a 4-inch course of asphalt treated base (ATB), or use existing pavement. Do not use crushed concrete, cement, or calcium chloride for construction entrance stabilization because these products raise pH levels in stormwater and concrete discharge to surface waters of the State is prohibited.

A separation geotextile shall be placed under the spalls to prevent fine sediment from pumping up into the rock pad. The geotextile shall meet the following standards:

Grab Tensile Strength (ASTM D4751)	200 psi min.
Grab Tensile Elongation (ASTM D4632)	30% max.
Mullen Burst Strength (ASTM D3786-80a)	400 psi min.
AOS (ASTM D4751)	20-45 (U.S. standard sieve size)

- Consider early installation of the first lift of asphalt in areas that will be paved; this can be used as a stabilized entrance. Also consider the installation of excess concrete as a stabilized entrance. During large concrete pours, excess concrete is often available for this purpose.

- Fencing (see [BMP C103](#)) shall be installed as necessary to restrict traffic to the construction entrance.
- Whenever possible, the entrance shall be constructed on a firm, compacted subgrade. This can substantially increase the effectiveness of the pad and reduce the need for maintenance.
- Construction entrances should avoid crossing existing sidewalks and back of walk drains if at all possible. If a construction entrance must cross a sidewalk or back of walk drain, the full length of the sidewalk and back of walk drain must be covered and protected from sediment leaving the site.

Maintenance Standards

Quarry spalls shall be added if the pad is no longer in accordance with the specifications.

- If the entrance is not preventing sediment from being tracked onto pavement, then alternative measures to keep the streets free of sediment shall be used. This may include replacement/cleaning of the existing quarry spalls, street sweeping, an increase in the dimensions of the entrance, or the installation of a wheel wash.
- Any sediment that is tracked onto pavement shall be removed by shoveling or street sweeping. The sediment collected by sweeping shall be removed or stabilized on site. The pavement shall not be cleaned by washing down the street, except when high efficiency sweeping is ineffective and there is a threat to public safety. If it is necessary to wash the streets, the construction of a small sump to contain the wash water shall be considered. The sediment would then be washed into the sump where it can be controlled.
- Perform street sweeping by hand or with a high efficiency sweeper. Do not use a non-high efficiency mechanical sweeper because this creates dust and throws soils into storm systems or conveyance ditches.
- Any quarry spalls that are loosened from the pad, which end up on the roadway shall be removed immediately.
- If vehicles are entering or exiting the site at points other than the construction entrance(s), fencing (see [BMP C103](#)) shall be installed to control traffic.
- Upon project completion and site stabilization, all construction accesses intended as permanent access for maintenance shall be permanently stabilized.

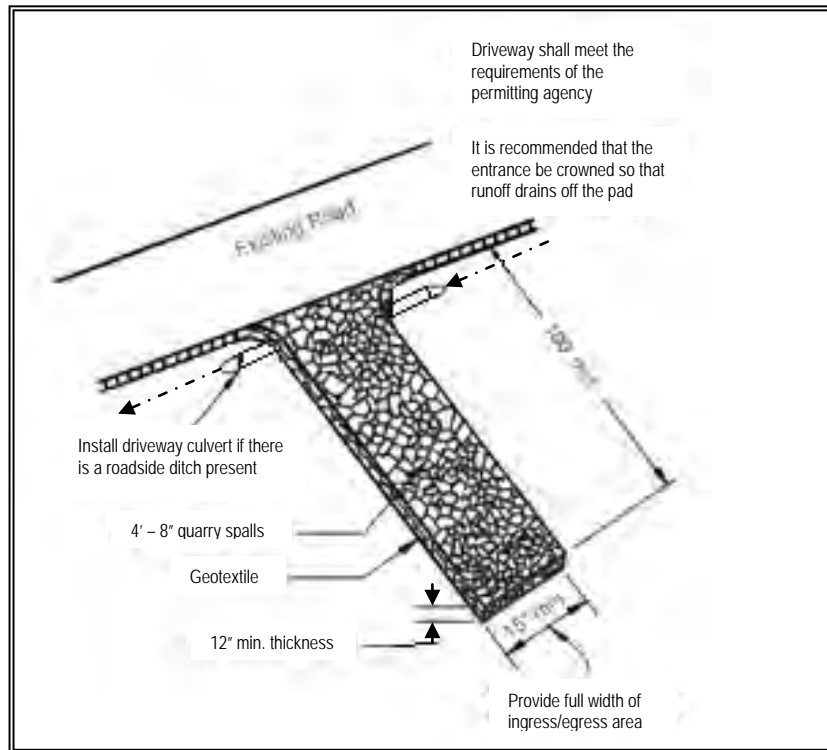

Figure 4.1.1 – Stabilized Construction Entrance

Approved as Equivalent

Ecology has approved products as able to meet the requirements of [BMP C105](#). The products did not pass through the Technology Assessment Protocol – Ecology (TAPE) process. Local jurisdictions may choose not to accept this product approved as equivalent, or may require additional testing prior to consideration for local use. The products are available for review on Ecology’s website at <http://www.ecy.wa.gov/programs/wq/stormwater/newtech/equivalent.html>

BMP C123: Plastic Covering

Purpose

Plastic covering provides immediate, short-term erosion protection to slopes and disturbed areas.

Conditions of Use

Plastic covering may be used on disturbed areas that require cover measures for less than 30 days, except as stated below.

- Plastic is particularly useful for protecting cut and fill slopes and stockpiles. Note: The relatively rapid breakdown of most polyethylene sheeting makes it unsuitable for long-term (greater than six months) applications.
- Due to rapid runoff caused by plastic covering, do not use this method upslope of areas that might be adversely impacted by concentrated runoff. Such areas include steep and/or unstable slopes.
- Plastic sheeting may result in increased runoff volumes and velocities, requiring additional on-site measures to counteract the increases. Creating a trough with wattles or other material can convey clean water away from these areas.
- To prevent undercutting, trench and backfill rolled plastic covering products.
- While plastic is inexpensive to purchase, the added cost of installation, maintenance, removal, and disposal make this an expensive material, up to \$1.50-2.00 per square yard.
- Whenever plastic is used to protect slopes install water collection measures at the base of the slope. These measures include plastic-covered berms, channels, and pipes used to convey clean rainwater away from bare soil and disturbed areas. Do not mix clean runoff from a plastic covered slope with dirty runoff from a project.
- Other uses for plastic include:
 1. Temporary ditch liner.
 2. Pond liner in temporary sediment pond.
 3. Liner for bermed temporary fuel storage area if plastic is not reactive to the type of fuel being stored.
 4. Emergency slope protection during heavy rains.
 5. Temporary drainpipe (“elephant trunk”) used to direct water.
- Plastic slope cover must be installed as follows:
 1. Run plastic up and down slope, not across slope.
 2. Plastic may be installed perpendicular to a slope if the slope length is less than 10 feet.
 3. Minimum of 8-inch overlap at seams.

Design and Installation Specifications

4. On long or wide slopes, or slopes subject to wind, tape all seams.
 5. Place plastic into a small (12-inch wide by 6-inch deep) slot trench at the top of the slope and backfill with soil to keep water from flowing underneath.
 6. Place sand filled burlap or geotextile bags every 3 to 6 feet along seams and tie them together with twine to hold them in place.
 7. Inspect plastic for rips, tears, and open seams regularly and repair immediately. This prevents high velocity runoff from contacting bare soil which causes extreme erosion.
 8. Sandbags may be lowered into place tied to ropes. However, all sandbags must be staked in place.
- Plastic sheeting shall have a minimum thickness of 0.06 millimeters.
 - If erosion at the toe of a slope is likely, a gravel berm, riprap, or other suitable protection shall be installed at the toe of the slope in order to reduce the velocity of runoff.
 - Torn sheets must be replaced and open seams repaired.
 - Completely remove and replace the plastic if it begins to deteriorate due to ultraviolet radiation.
 - Completely remove plastic when no longer needed.
 - Dispose of old tires used to weight down plastic sheeting appropriately.

Maintenance Standards

Approved as Equivalent

Ecology has approved products as able to meet the requirements of [BMP C123](#). The products did not pass through the Technology Assessment Protocol – Ecology (TAPE) process. Local jurisdictions may choose not to accept this product approved as equivalent, or may require additional testing prior to consideration for local use. The products are available for review on Ecology’s website at <http://www.ecy.wa.gov/programs/wq/stormwater/newtech/equivalent.html>

BMP C140: Dust Control

- Purpose*** Dust control prevents wind transport of dust from disturbed soil surfaces onto roadways, drainage ways, and surface waters.
- Conditions of Use***
- In areas (including roadways) subject to surface and air movement of dust where on-site and off-site impacts to roadways, drainage ways, or surface waters are likely.
- Design and Installation Specifications***
- Vegetate or mulch areas that will not receive vehicle traffic. In areas where planting, mulching, or paving is impractical, apply gravel or landscaping rock.
 - Limit dust generation by clearing only those areas where immediate activity will take place, leaving the remaining area(s) in the original condition. Maintain the original ground cover as long as practical.
 - Construct natural or artificial windbreaks or windscreens. These may be designed as enclosures for small dust sources.
 - Sprinkle the site with water until surface is wet. Repeat as needed. To prevent carryout of mud onto street, refer to Stabilized Construction Entrance ([BMP C105](#)).
 - Irrigation water can be used for dust control. Irrigation systems should be installed as a first step on sites where dust control is a concern.
 - Spray exposed soil areas with a dust palliative, following the manufacturer's instructions and cautions regarding handling and application. Used oil is prohibited from use as a dust suppressant. Local governments may approve other dust palliatives such as calcium chloride or PAM.
 - PAM ([BMP C126](#)) added to water at a rate of 0.5 lbs. per 1,000 gallons of water per acre and applied from a water truck is more effective than water alone. This is due to increased infiltration of water into the soil and reduced evaporation. In addition, small soil particles are bonded together and are not as easily transported by wind. Adding PAM may actually reduce the quantity of water needed for dust control. Use of PAM could be a cost-effective dust control method.

Techniques that can be used for unpaved roads and lots include:

- Lower speed limits. High vehicle speed increases the amount of dust stirred up from unpaved roads and lots.
- Upgrade the road surface strength by improving particle size, shape, and mineral types that make up the surface and base materials.
- Add surface gravel to reduce the source of dust emission. Limit the amount of fine particles (those smaller than .075 mm) to 10 to 20 percent.

- Use geotextile fabrics to increase the strength of new roads or roads undergoing reconstruction.
- Encourage the use of alternate, paved routes, if available.
- Restrict use of paved roadways by tracked vehicles and heavy trucks to prevent damage to road surface and base.
- Apply chemical dust suppressants using the admix method, blending the product with the top few inches of surface material. Suppressants may also be applied as surface treatments.
- Pave unpaved permanent roads and other trafficked areas.
- Use vacuum street sweepers.
- Remove mud and other dirt promptly so it does not dry and then turn into dust.
- Limit dust-causing work on windy days.
- Contact your local Air Pollution Control Authority for guidance and training on other dust control measures. Compliance with the local Air Pollution Control Authority constitutes compliance with this BMP.

***Maintenance
Standards***

Respray area as necessary to keep dust to a minimum.

BMP C150: Materials on Hand

Purpose Keep quantities of erosion prevention and sediment control materials on the project site at all times to be used for regular maintenance and emergency situations such as unexpected heavy summer rains. Having these materials on-site reduces the time needed to implement BMPs when inspections indicate that existing BMPs are not meeting the Construction SWPPP requirements. In addition, contractors can save money by buying some materials in bulk and storing them at their office or yard.

- Conditions of Use**
- Construction projects of any size or type can benefit from having materials on hand. A small commercial development project could have a roll of plastic and some gravel available for immediate protection of bare soil and temporary berm construction. A large earthwork project, such as highway construction, might have several tons of straw, several rolls of plastic, flexible pipe, sandbags, geotextile fabric and steel “T” posts.
 - Materials are stockpiled and readily available before any site clearing, grubbing, or earthwork begins. A large contractor or developer could keep a stockpile of materials that are available for use on several projects.
 - If storage space at the project site is at a premium, the contractor could maintain the materials at their office or yard. The office or yard must be less than an hour from the project site.

Design and Installation Specifications

Depending on project type, size, complexity, and length, materials and quantities will vary. A good minimum list of items that will cover numerous situations includes:

Material
Clear Plastic, 6 mil
Drainpipe, 6 or 8 inch diameter
Sandbags, filled
Straw Bales for mulching,
Quarry Spalls
Washed Gravel
Geotextile Fabric
Catch Basin Inserts
Steel “T” Posts
Silt fence material
Straw Wattles

- Maintenance Standards**
- All materials with the exception of the quarry spalls, steel “T” posts, and gravel should be kept covered and out of both sun and rain.
 - Re-stock materials used as needed.

BMP C151: Concrete Handling

Purpose Concrete work can generate process water and slurry that contain fine particles and high pH, both of which can violate water quality standards in the receiving water. Concrete spillage or concrete discharge to surface waters of the State is prohibited. Use this BMP to minimize and eliminate concrete, concrete process water, and concrete slurry from entering waters of the state.

Conditions of Use Any time concrete is used, utilize these management practices. Concrete construction projects include, but are not limited to, the following:

- Curbs
- Sidewalks
- Roads
- Bridges
- Foundations
- Floors
- Runways
- Wash out concrete truck chutes, pumps, and internals into formed areas only. Assure that washout of concrete trucks is performed off-site or in designated concrete washout areas. Do not wash out concrete trucks onto the ground, or into storm drains, open ditches, streets, or streams. Refer to [BMP C154](#) for information on concrete washout areas.
- Return unused concrete remaining in the truck and pump to the originating batch plant for recycling. Do not dump excess concrete on site, except in designated concrete washout areas.
- Wash off hand tools including, but not limited to, screeds, shovels, rakes, floats, and trowels into formed areas only.
- Wash equipment difficult to move, such as concrete pavers in areas that do not directly drain to natural or constructed stormwater conveyances.
- Do not allow washdown from areas, such as concrete aggregate driveways, to drain directly to natural or constructed stormwater conveyances.

**Design and
Installation
Specifications**

- Contain washwater and leftover product in a lined container when no formed areas are available,. Dispose of contained concrete in a manner that does not violate ground water or surface water quality standards.
- Always use forms or solid barriers for concrete pours, such as pilings, within 15-feet of surface waters.
- Refer to [BMPs C252](#) and [C253](#) for pH adjustment requirements.
- Refer to the Construction Stormwater General Permit for pH monitoring requirements if the project involves one of the following activities:
 - Significant concrete work (greater than 1,000 cubic yards poured concrete or recycled concrete used over the life of a project).
 - The use of engineered soils amended with (but not limited to) Portland cement-treated base, cement kiln dust or fly ash.
 - Discharging stormwater to segments of water bodies on the 303(d) list (Category 5) for high pH.

***Maintenance
Standards***

Check containers for holes in the liner daily during concrete pours and repair the same day.

BMP C152: Sawcutting and Surfacing Pollution Prevention

<i>Purpose</i>	Sawcutting and surfacing operations generate slurry and process water that contains fine particles and high pH (concrete cutting), both of which can violate the water quality standards in the receiving water. Concrete spillage or concrete discharge to surface waters of the State is prohibited. Use this BMP to minimize and eliminate process water and slurry created through sawcutting or surfacing from entering waters of the State.
<i>Conditions of Use</i>	Utilize these management practices anytime sawcutting or surfacing operations take place. Sawcutting and surfacing operations include, but are not limited to, the following: <ul style="list-style-type: none">• Sawing• Coring• Grinding• Roughening• Hydro-demolition• Bridge and road surfacing
<i>Design and Installation Specifications</i>	<ul style="list-style-type: none">• Vacuum slurry and cuttings during cutting and surfacing operations.• Slurry and cuttings shall not remain on permanent concrete or asphalt pavement overnight.• Slurry and cuttings shall not drain to any natural or constructed drainage conveyance including stormwater systems. This may require temporarily blocking catch basins.• Dispose of collected slurry and cuttings in a manner that does not violate ground water or surface water quality standards.• Do not allow process water generated during hydro-demolition, surface roughening or similar operations to drain to any natural or constructed drainage conveyance including stormwater systems. Dispose process water in a manner that does not violate ground water or surface water quality standards.• Handle and dispose cleaning waste material and demolition debris in a manner that does not cause contamination of water. Dispose of sweeping material from a pick-up sweeper at an appropriate disposal site.
<i>Maintenance Standards</i>	Continually monitor operations to determine whether slurry, cuttings, or process water could enter waters of the state. If inspections show that a violation of water quality standards could occur, stop operations and immediately implement preventive measures such as berms, barriers, secondary containment, and vacuum trucks.

BMP C153: Material Delivery, Storage and Containment

Purpose

Prevent, reduce, or eliminate the discharge of pollutants to the stormwater system or watercourses from material delivery and storage. Minimize the storage of hazardous materials on-site, store materials in a designated area, and install secondary containment.

Conditions of Use

These procedures are suitable for use at all construction sites with delivery and storage of the following materials:

- Petroleum products such as fuel, oil and grease
- Soil stabilizers and binders (e.g. Polyacrylamide)
- Fertilizers, pesticides and herbicides
- Detergents
- Asphalt and concrete compounds
- Hazardous chemicals such as acids, lime, adhesives, paints, solvents and curing compounds
- Any other material that may be detrimental if released to the environment

Design and Installation Specifications

The following steps should be taken to minimize risk:

- Temporary storage area should be located away from vehicular traffic, near the construction entrance(s), and away from waterways or storm drains.
- Material Safety Data Sheets (MSDS) should be supplied for all materials stored. Chemicals should be kept in their original labeled containers.
- Hazardous material storage on-site should be minimized.
- Hazardous materials should be handled as infrequently as possible.
- During the wet weather season (Oct 1 – April 30), consider storing materials in a covered area.
- Materials should be stored in secondary containments, such as earthen dike, horse trough, or even a children’s wading pool for non-reactive materials such as detergents, oil, grease, and paints. Small amounts of material may be secondarily contained in “bus boy” trays or concrete mixing trays.
- Do not store chemicals, drums, or bagged materials directly on the ground. Place these items on a pallet and, when possible, and within secondary containment.
- If drums must be kept uncovered, store them at a slight angle to reduce ponding of rainwater on the lids to reduce corrosion. Domed plastic covers are inexpensive and snap to the top of drums, preventing water from collecting.

Material Storage Areas and Secondary Containment Practices:

- Liquids, petroleum products, and substances listed in 40 CFR Parts 110, 117, or 302 shall be stored in approved containers and drums and shall not be overfilled. Containers and drums shall be stored in temporary secondary containment facilities.
- Temporary secondary containment facilities shall provide for a spill containment volume able to contain 10% of the total enclosed container volume of all containers, or 110% of the capacity of the largest container within its boundary, whichever is greater.
- Secondary containment facilities shall be impervious to the materials stored therein for a minimum contact time of 72 hours.
- Secondary containment facilities shall be maintained free of accumulated rainwater and spills. In the event of spills or leaks, accumulated rainwater and spills shall be collected and placed into drums. These liquids shall be handled as hazardous waste unless testing determines them to be non-hazardous.
- Sufficient separation should be provided between stored containers to allow for spill cleanup and emergency response access.
- During the wet weather season (Oct 1 – April 30), each secondary containment facility shall be covered during non-working days, prior to and during rain events.
- Keep material storage areas clean, organized and equipped with an ample supply of appropriate spill clean-up material (spill kit).
- The spill kit should include, at a minimum:
 - 1-Water Resistant Nylon Bag
 - 3-Oil Absorbent Socks 3”x 4’
 - 2-Oil Absorbent Socks 3”x 10’
 - 12-Oil Absorbent Pads 17”x19”
 - 1-Pair Splash Resistant Goggles
 - 3-Pair Nitrile Gloves
 - 10-Disposable Bags with Ties
 - Instructions

BMP C160: Certified Erosion and Sediment Control Lead

Purpose

The project proponent designates at least one person as the responsible representative in charge of erosion and sediment control (ESC), and water quality protection. The designated person shall be the Certified Erosion and Sediment Control Lead (CESCL) who is responsible for ensuring compliance with all local, state, and federal erosion and sediment control and water quality requirements.

Conditions of Use

A CESCL shall be made available on projects one acre or larger that discharge stormwater to surface waters of the state. Sites less than one acre may have a person without CESCL certification conduct inspections; sampling is not required on sites that disturb less than an acre.

- The CESCL shall:
 - Have a current certificate proving attendance in an erosion and sediment control training course that meets the minimum ESC training and certification requirements established by Ecology (see details below).

Ecology will maintain a list of ESC training and certification providers at:

<http://www.ecy.wa.gov/programs/wq/stormwater/cescl.html>

OR

- Be a Certified Professional in Erosion and Sediment Control (CPESC); for additional information go to: www.cpesc.net

Specifications

- Certification shall remain valid for three years.
- The CESCL shall have authority to act on behalf of the contractor or developer and shall be available, or on-call, 24 hours per day throughout the period of construction.
- The Construction SWPPP shall include the name, telephone number, fax number, and address of the designated CESCL.
- A CESCL may provide inspection and compliance services for multiple construction projects in the same geographic region.

Duties and responsibilities of the CESCL shall include, but are not limited to the following:

- Maintaining permit file on site at all times which includes the Construction SWPPP and any associated permits and plans.
- Directing BMP installation, inspection, maintenance, modification, and removal.

- Updating all project drawings and the Construction SWPPP with changes made.
- Completing any sampling requirements including reporting results using WebDMR.
- Keeping daily logs, and inspection reports. Inspection reports should include:
 - Inspection date/time.
 - Weather information; general conditions during inspection and approximate amount of precipitation since the last inspection.
 - A summary or list of all BMPs implemented, including observations of all erosion/sediment control structures or practices. The following shall be noted:
 1. Locations of BMPs inspected.
 2. Locations of BMPs that need maintenance.
 3. Locations of BMPs that failed to operate as designed or intended.
 4. Locations of where additional or different BMPs are required.
 - Visual monitoring results, including a description of discharged stormwater. The presence of suspended sediment, turbid water, discoloration, and oil sheen shall be noted, as applicable.
 - Any water quality monitoring performed during inspection.
 - General comments and notes, including a brief description of any BMP repairs, maintenance or installations made as a result of the inspection.
- Facilitate, participate in, and take corrective actions resulting from inspections performed by outside agencies or the owner.

BMP C209: Outlet Protection

<i>Purpose</i>	Outlet protection prevents scour at conveyance outlets and minimizes the potential for downstream erosion by reducing the velocity of concentrated stormwater flows.
<i>Conditions of use</i>	Outlet protection is required at the outlets of all ponds, pipes, ditches, or other conveyances, and where runoff is conveyed to a natural or manmade drainage feature such as a stream, wetland, lake, or ditch.
<i>Design and Installation Specifications</i>	<p>The receiving channel at the outlet of a culvert shall be protected from erosion by rock lining a minimum of 6 feet downstream and extending up the channel sides a minimum of 1-foot above the maximum tailwater elevation or 1-foot above the crown, whichever is higher. For large pipes (more than 18 inches in diameter), the outlet protection lining of the channel is lengthened to four times the diameter of the culvert.</p> <ul style="list-style-type: none">• Standard wingwalls, and tapered outlets and paved channels should also be considered when appropriate for permanent culvert outlet protection. (See WSDOT Hydraulic Manual, available through WSDOT Engineering Publications).• Organic or synthetic erosion blankets, with or without vegetation, are usually more effective than rock, cheaper, and easier to install. Materials can be chosen using manufacturer product specifications. ASTM test results are available for most products and the designer can choose the correct material for the expected flow.• With low flows, vegetation (including sod) can be effective.• The following guidelines shall be used for riprap outlet protection:<ol style="list-style-type: none">1. If the discharge velocity at the outlet is less than 5 fps (pipe slope less than 1 percent), use 2-inch to 8-inch riprap. Minimum thickness is 1-foot.2. For 5 to 10 fps discharge velocity at the outlet (pipe slope less than 3 percent), use 24-inch to 48-inch riprap. Minimum thickness is 2 feet.3. For outlets at the base of steep slope pipes (pipe slope greater than 10 percent), an engineered energy dissipater shall be used.• Filter fabric or erosion control blankets should always be used under riprap to prevent scour and channel erosion.

- New pipe outfalls can provide an opportunity for low-cost fish habitat improvements. For example, an alcove of low-velocity water can be created by constructing the pipe outfall and associated energy dissipater back from the stream edge and digging a channel, over-widened to the upstream side, from the outfall. Overwintering juvenile and migrating adult salmonids may use the alcove as shelter during high flows. Bank stabilization, bioengineering, and habitat features may be required for disturbed areas. This work may require a HPA. See Volume V for more information on outfall system design.

***Maintenance
Standards***

- Inspect and repair as needed.
- Add rock as needed to maintain the intended function.
- Clean energy dissipater if sediment builds up.

BMP C220: Storm Drain Inlet Protection

Purpose Storm drain inlet protection prevents coarse sediment from entering drainage systems prior to permanent stabilization of the disturbed area.

Conditions of Use Use storm drain inlet protection at inlets that are operational before permanent stabilization of the disturbed drainage area. Provide protection for all storm drain inlets downslope and within 500 feet of a disturbed or construction area, unless conveying runoff entering catch basins to a sediment pond or trap.

Also consider inlet protection for lawn and yard drains on new home construction. These small and numerous drains coupled with lack of gutters in new home construction can add significant amounts of sediment into the roof drain system. If possible delay installing lawn and yard drains until just before landscaping or cap these drains to prevent sediment from entering the system until completion of landscaping. Provide 18-inches of sod around each finished lawn and yard drain.

[Table 4.2.2](#) lists several options for inlet protection. All of the methods for storm drain inlet protection tend to plug and require a high frequency of maintenance. Limit drainage areas to one acre or less. Possibly provide emergency overflows with additional end-of-pipe treatment where stormwater ponding would cause a hazard.

Table 4.2.2 Storm Drain Inlet Protection			
Type of Inlet Protection	Emergency Overflow	Applicable for Paved/ Earthen Surfaces	Conditions of Use
Drop Inlet Protection			
Excavated drop inlet protection	Yes, temporary flooding will occur	Earthen	Applicable for heavy flows. Easy to maintain. Large area Requirement: 30' X 30'/acre
Block and gravel drop inlet protection	Yes	Paved or Earthen	Applicable for heavy concentrated flows. Will not pond.
Gravel and wire drop inlet protection	No		Applicable for heavy concentrated flows. Will pond. Can withstand traffic.
Catch basin filters	Yes	Paved or Earthen	Frequent maintenance required.
Curb Inlet Protection			
Curb inlet protection with a wooden weir	Small capacity overflow	Paved	Used for sturdy, more compact installation.
Block and gravel curb inlet protection	Yes	Paved	Sturdy, but limited filtration.
Culvert Inlet Protection			
Culvert inlet sediment trap			18 month expected life.

***Design and
Installation
Specifications***

Excavated Drop Inlet Protection - An excavated impoundment around the storm drain. Sediment settles out of the stormwater prior to entering the storm drain.

- Provide a depth of 1-2 ft as measured from the crest of the inlet structure.
- Slope sides of excavation no steeper than 2H:1V.
- Minimum volume of excavation 35 cubic yards.
- Shape basin to fit site with longest dimension oriented toward the longest inflow area.
- Install provisions for draining to prevent standing water problems.
- Clear the area of all debris.
- Grade the approach to the inlet uniformly.
- Drill weep holes into the side of the inlet.
- Protect weep holes with screen wire and washed aggregate.
- Seal weep holes when removing structure and stabilizing area.
- Build a temporary dike, if necessary, to the down slope side of the structure to prevent bypass flow.

Block and Gravel Filter - A barrier formed around the storm drain inlet with standard concrete blocks and gravel. See [Figure 4.2.8](#).

- Provide a height of 1 to 2 feet above inlet.
- Recess the first row 2-inches into the ground for stability.
- Support subsequent courses by placing a 2x4 through the block opening.
- Do not use mortar.
- Lay some blocks in the bottom row on their side for dewatering the pool.
- Place hardware cloth or comparable wire mesh with ½-inch openings over all block openings.
- Place gravel just below the top of blocks on slopes of 2H:1V or flatter.
- An alternative design is a gravel donut.
- Provide an inlet slope of 3H:1V.
- Provide an outlet slope of 2H:1V.
- Provide a 1-foot wide level stone area between the structure and the inlet.
- Use inlet slope stones 3 inches in diameter or larger.
- Use gravel ½- to ¾-inch at a minimum thickness of 1-foot for the outlet slope.

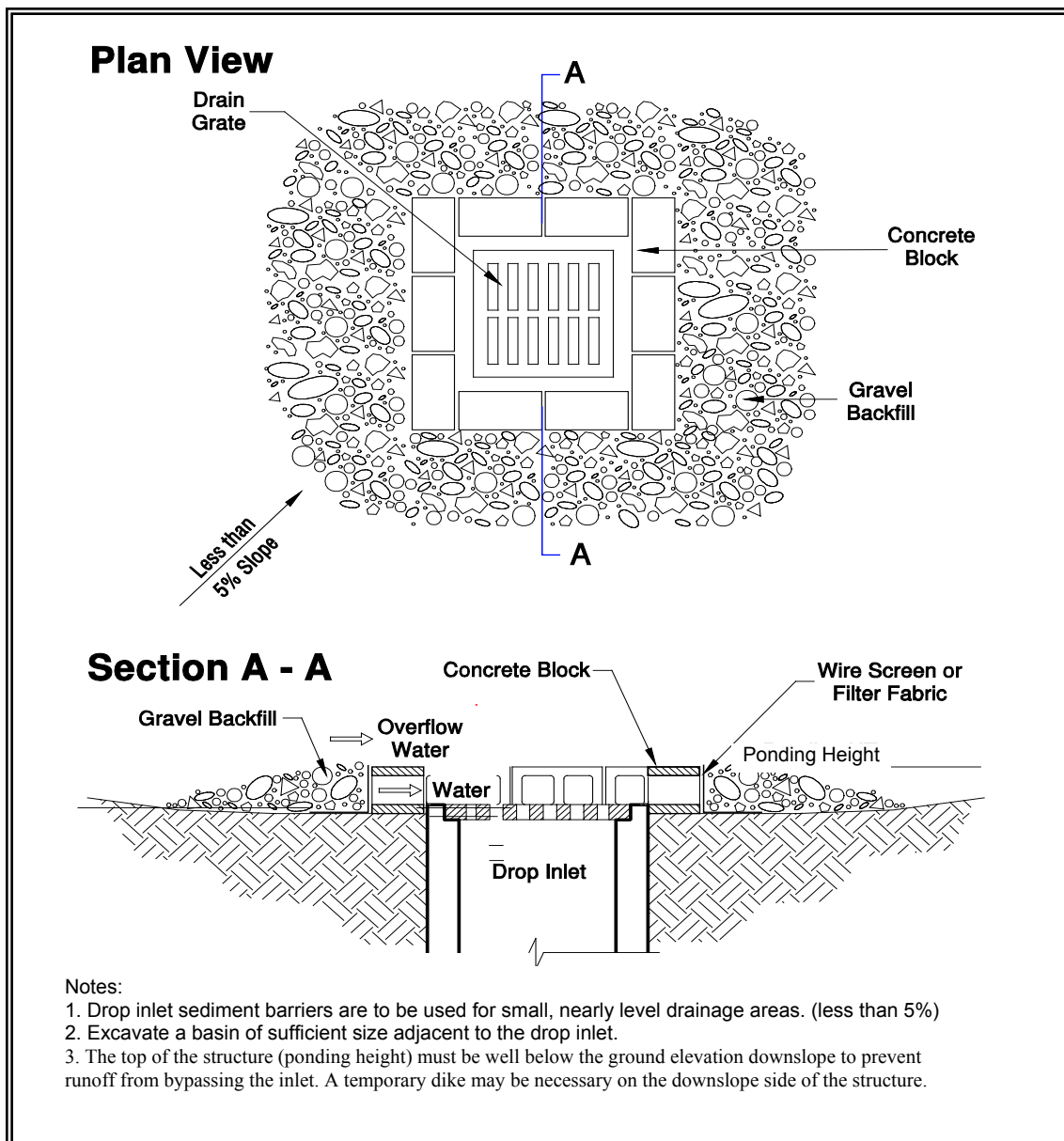

Figure 4.2.8 – Block and Gravel Filter

Gravel and Wire Mesh Filter - A gravel barrier placed over the top of the inlet. This structure does not provide an overflow.

- Use a hardware cloth or comparable wire mesh with ½-inch openings.
- Use coarse aggregate.
- Provide a height 1-foot or more, 18-inches wider than inlet on all sides.
- Place wire mesh over the drop inlet so that the wire extends a minimum of 1-foot beyond each side of the inlet structure.
- Overlap the strips if more than one strip of mesh is necessary.

- Place coarse aggregate over the wire mesh.
- Provide at least a 12-inch depth of gravel over the entire inlet opening and extend at least 18-inches on all sides.

Catchbasin Filters – Use inserts designed by manufacturers for construction sites. The limited sediment storage capacity increases the amount of inspection and maintenance required, which may be daily for heavy sediment loads. To reduce maintenance requirements combine a catchbasin filter with another type of inlet protection. This type of inlet protection provides flow bypass without overflow and therefore may be a better method for inlets located along active rights-of-way.

- Provides 5 cubic feet of storage.
- Requires dewatering provisions.
- Provides a high-flow bypass that will not clog under normal use at a construction site.
- Insert the catchbasin filter in the catchbasin just below the grating.

Curb Inlet Protection with Wooden Weir – Barrier formed around a curb inlet with a wooden frame and gravel.

- Use wire mesh with ½-inch openings.
- Use extra strength filter cloth.
- Construct a frame.
- Attach the wire and filter fabric to the frame.
- Pile coarse washed aggregate against wire/fabric.
- Place weight on frame anchors.

Block and Gravel Curb Inlet Protection – Barrier formed around a curb inlet with concrete blocks and gravel. See [Figure 4.2.9](#).

- Use wire mesh with ½-inch openings.
- Place two concrete blocks on their sides abutting the curb at either side of the inlet opening. These are spacer blocks.
- Place a 2x4 stud through the outer holes of each spacer block to align the front blocks.
- Place blocks on their sides across the front of the inlet and abutting the spacer blocks.
- Place wire mesh over the outside vertical face.
- Pile coarse aggregate against the wire to the top of the barrier.

Curb and Gutter Sediment Barrier – Sandbag or rock berm (riprap and aggregate) 3 feet high and 3 feet wide in a horseshoe shape. See [Figure 4.2.10](#).

***Maintenance
Standards***

- Construct a horseshoe shaped berm, faced with coarse aggregate if using riprap, 3 feet high and 3 feet wide, at least 2 feet from the inlet.
- Construct a horseshoe shaped sedimentation trap on the outside of the berm sized to sediment trap standards for protecting a culvert inlet.
- Inspect catch basin filters frequently, especially after storm events. Clean and replace clogged inserts. For systems with clogged stone filters: pull away the stones from the inlet and clean or replace. An alternative approach would be to use the clogged stone as fill and put fresh stone around the inlet.
- Do not wash sediment into storm drains while cleaning. Spread all excavated material evenly over the surrounding land area or stockpile and stabilize as appropriate.

***Approved as
Equivalent***

Ecology has approved products as able to meet the requirements of [BMP C220](#). The products did not pass through the Technology Assessment Protocol – Ecology (TAPE) process. Local jurisdictions may choose not to accept this product approved as equivalent, or may require additional testing prior to consideration for local use. The products are available for review on Ecology’s website at <http://www.ecy.wa.gov/programs/wq/stormwater/newtech/equivalent.html>

Plan View

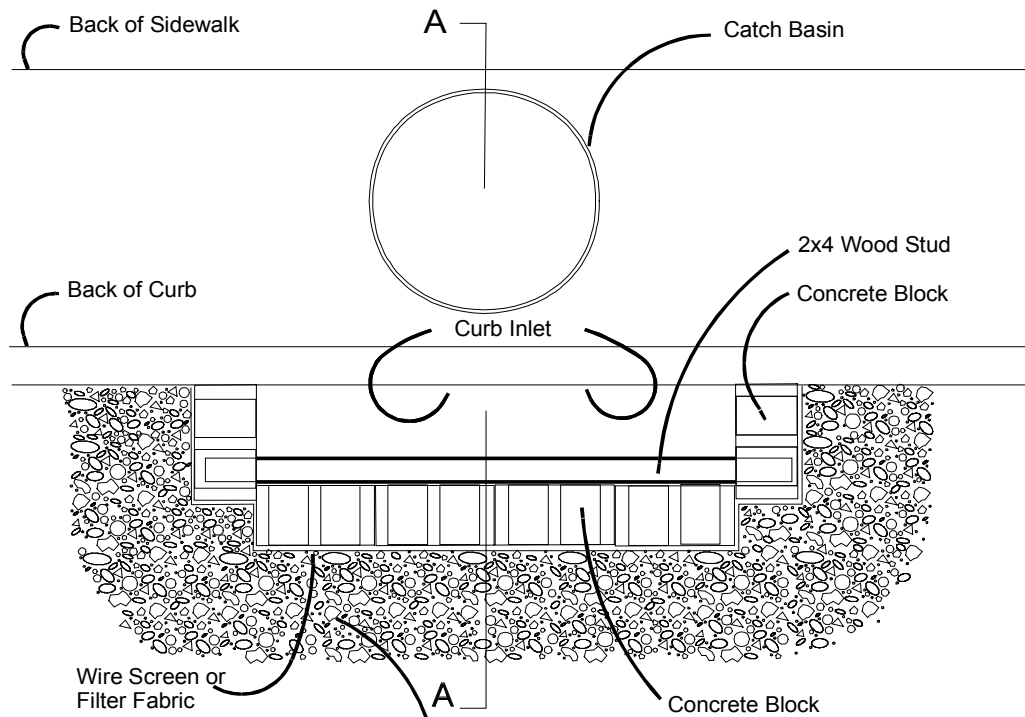

Section A - A

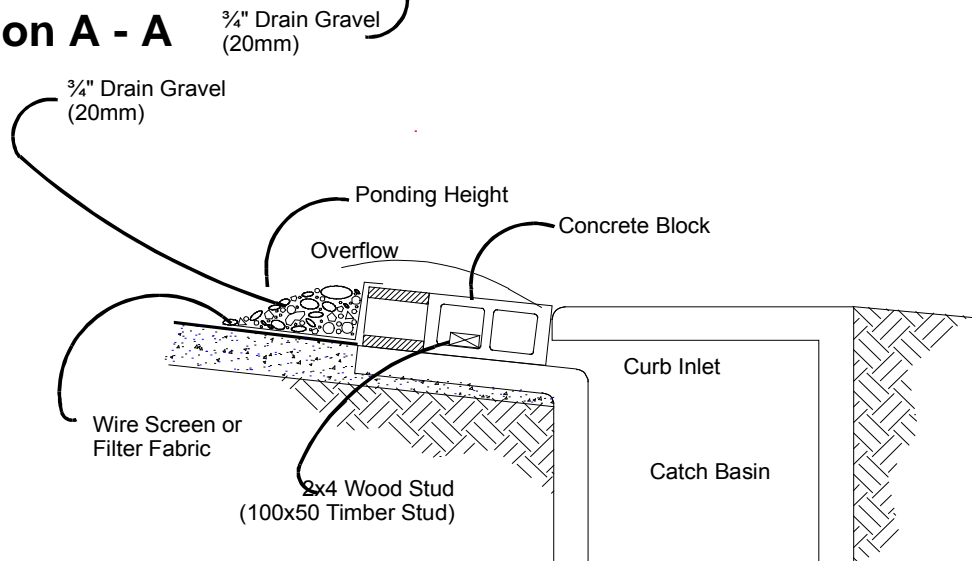

NOTES:

1. Use block and gravel type sediment barrier when curb inlet is located in gently sloping street segment, where water can pond and allow sediment to separate from runoff.
2. Barrier shall allow for overflow from severe storm event.
3. Inspect barriers and remove sediment after each storm event. Sediment and gravel must be removed from the traveled way immediately.

Figure 4.2.9 – Block and Gravel Curb Inlet Protection

Plan View

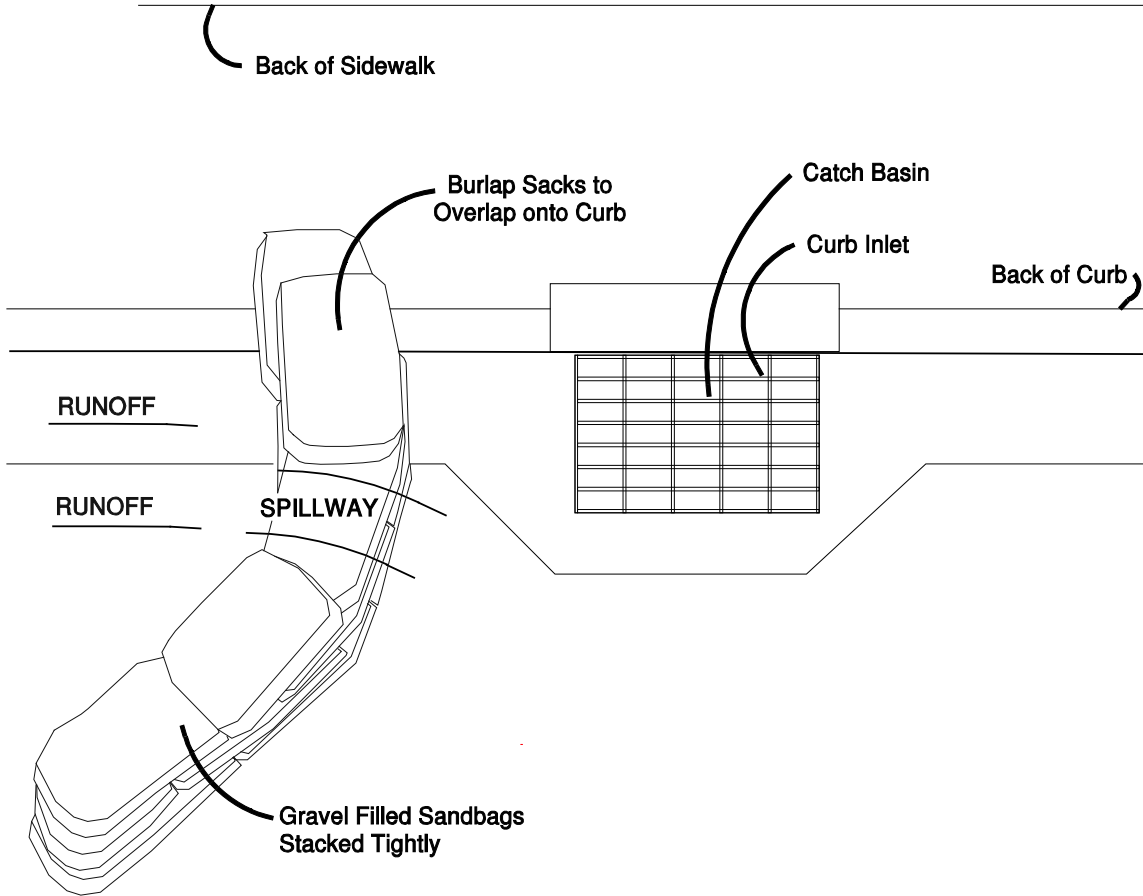

NOTES:

1. Place curb type sediment barriers on gently sloping street segments, where water can pond and allow sediment to separate from runoff.
2. Sandbags of either burlap or woven 'geotextile' fabric, are filled with gravel, layered and packed tightly.
3. Leave a one sandbag gap in the top row to provide a spillway for overflow.
4. Inspect barriers and remove sediment after each storm event. Sediment and gravel must be removed from the traveled way immediately.

Figure 4.2.10 – Curb and Gutter Barrier

BMP C232: Gravel Filter Berm

<i>Purpose</i>	A gravel filter berm is constructed on rights-of-way or traffic areas within a construction site to retain sediment by using a filter berm of gravel or crushed rock.
<i>Conditions of Use</i>	Where a temporary measure is needed to retain sediment from rights-of-way or in traffic areas on construction sites.
<i>Design and Installation Specifications</i>	<ul style="list-style-type: none">• Berm material shall be $\frac{3}{4}$ to 3 inches in size, washed well-grade gravel or crushed rock with less than 5 percent fines.• Spacing of berms:<ul style="list-style-type: none">– Every 300 feet on slopes less than 5 percent– Every 200 feet on slopes between 5 percent and 10 percent– Every 100 feet on slopes greater than 10 percent• Berm dimensions:<ul style="list-style-type: none">– 1 foot high with 3H:1V side slopes– 8 linear feet per 1 cfs runoff based on the 10-year, 24-hour design storm
<i>Maintenance Standards</i>	<ul style="list-style-type: none">• Regular inspection is required. Sediment shall be removed and filter material replaced as needed.

Appendix C – Alternative BMPs

BMP C102: Buffer Zones

<i>Purpose</i>	Creation of an undisturbed area or strip of natural vegetation or an established suitable planting that will provide a living filter to reduce soil erosion and runoff velocities.
<i>Conditions of Use</i>	<p>Natural buffer zones are used along streams, wetlands and other bodies of water that need protection from erosion and sedimentation. Vegetative buffer zones can be used to protect natural swales and can be incorporated into the natural landscaping of an area.</p> <p>Critical-areas buffer zones should not be used as sediment treatment areas. These areas shall remain completely undisturbed. The local permitting authority may expand the buffer widths temporarily to allow the use of the expanded area for removal of sediment.</p>
<i>Design and Installation Specifications</i>	<ul style="list-style-type: none">• Preserving natural vegetation or plantings in clumps, blocks, or strips is generally the easiest and most successful method.• Leave all unstable steep slopes in natural vegetation.• Mark clearing limits and keep all equipment and construction debris out of the natural areas and buffer zones. Steel construction fencing is the most effective method in protecting sensitive areas and buffers. Alternatively, wire-backed silt fence on steel posts is marginally effective. Flagging alone is typically not effective.• Keep all excavations outside the dripline of trees and shrubs.• Do not push debris or extra soil into the buffer zone area because it will cause damage from burying and smothering.• Vegetative buffer zones for streams, lakes or other waterways shall be established by the local permitting authority or other state or federal permits or approvals.
<i>Maintenance Standards</i>	Inspect the area frequently to make sure flagging remains in place and the area remains undisturbed. Replace all damaged flagging immediately.

BMP C106: Wheel Wash

Purpose

Wheel washes reduce the amount of sediment transported onto paved roads by motor vehicles.

Conditions of Use

When a stabilized construction entrance (see [BMP C105](#)) is not preventing sediment from being tracked onto pavement.

- Wheel washing is generally an effective BMP when installed with careful attention to topography. For example, a wheel wash can be detrimental if installed at the top of a slope abutting a right-of-way where the water from the dripping truck can run unimpeded into the street.
- Pressure washing combined with an adequately sized and surfaced pad with direct drainage to a large 10-foot x 10-foot sump can be very effective.
- Discharge wheel wash or tire bath wastewater to a separate on-site treatment system that prevents discharge to surface water, such as closed-loop recirculation or upland land application, or to the sanitary sewer with local sewer district approval.
- Wheel wash or tire bath wastewater should not include wastewater from concrete washout areas.

Design and Installation Specifications

Suggested details are shown in [Figure 4.1.2](#). The Local Permitting Authority may allow other designs. A minimum of 6 inches of asphalt treated base (ATB) over crushed base material or 8 inches over a good subgrade is recommended to pave the wheel wash.

Use a low clearance truck to test the wheel wash before paving. Either a belly dump or lowboy will work well to test clearance.

Keep the water level from 12 to 14 inches deep to avoid damage to truck hubs and filling the truck tongues with water.

Midpoint spray nozzles are only needed in extremely muddy conditions.

Wheel wash systems should be designed with a small grade change, 6- to 1-inches for a 10-foot-wide pond, to allow sediment to flow to the low side of pond to help prevent re-suspension of sediment. A drainpipe with a 2- to 3-foot riser should be installed on the low side of the pond to allow for easy cleaning and refilling. Polymers may be used to promote coagulation and flocculation in a closed-loop system. Polyacrylamide (PAM) added to the wheel wash water at a rate of 0.25 - 0.5 pounds per 1,000 gallons of water increases effectiveness and reduces cleanup time. If PAM is already being used for dust or erosion control and is being applied by a water truck, the same truck can be used to change the wash water.

Maintenance Standards

The wheel wash should start out the day with fresh water.

The wash water should be changed a minimum of once per day. On large earthwork jobs where more than 10-20 trucks per hour are expected, the wash water will need to be changed more often.

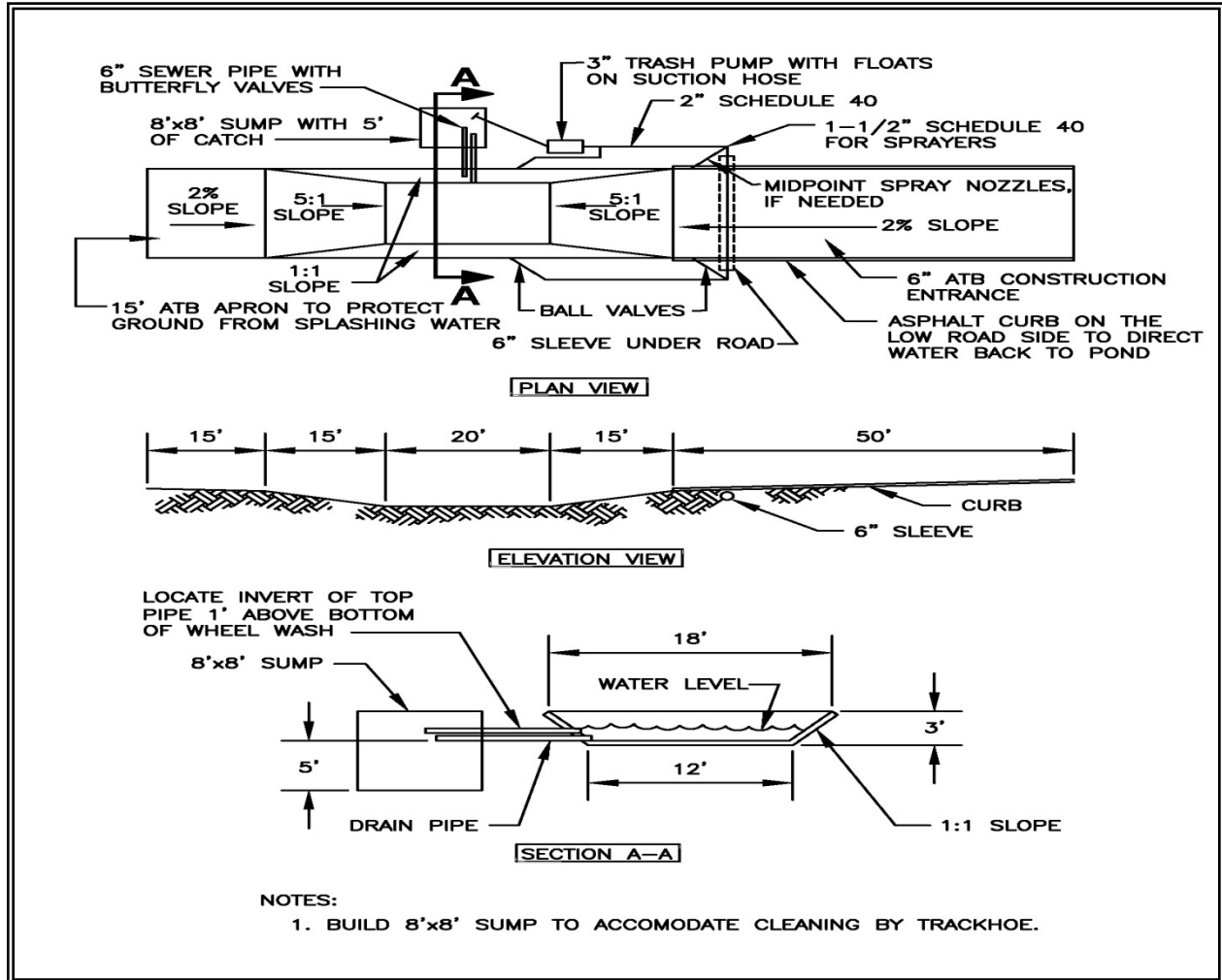

Figure 4.1.2 – Wheel Wash

Notes:

1. Asphalt construction entrance 6 in. asphalt treated base (ATB).
2. 3-inch trash pump with floats on the suction hose.
3. Midpoint spray nozzles, if needed.
4. 6-inch sewer pipe with butterfly valves. Bottom one is a drain. Locate top pipe's invert 1 foot above bottom of wheel wash.
5. 8 foot x 8 foot sump with 5 feet of catch. Build so the sump can be cleaned with a trackhoe.
6. Asphalt curb on the low road side to direct water back to pond.
7. 6-inch sleeve under road.
8. Ball valves.
9. 15 foot. ATB apron to protect ground from splashing water.

BMP C107: Construction Road/Parking Area Stabilization

<i>Purpose</i>	Stabilizing subdivision roads, parking areas, and other on-site vehicle transportation routes immediately after grading reduces erosion caused by construction traffic or runoff.
<i>Conditions of Use</i>	Roads or parking areas shall be stabilized wherever they are constructed, whether permanent or temporary, for use by construction traffic. <ul style="list-style-type: none">• High Visibility Fencing (see BMP C103) shall be installed, if necessary, to limit the access of vehicles to only those roads and parking areas that are stabilized.
<i>Design and Installation Specifications</i>	<ul style="list-style-type: none">• On areas that will receive asphalt as part of the project, install the first lift as soon as possible.• A 6-inch depth of 2- to 4-inch crushed rock, gravel base, or crushed surfacing base course shall be applied immediately after grading or utility installation. A 4-inch course of asphalt treated base (ATB) may also be used, or the road/parking area may be paved. It may also be possible to use cement or calcium chloride for soil stabilization. If cement or cement kiln dust is used for roadbase stabilization, pH monitoring and BMPs (BMPs C252 and C253) are necessary to evaluate and minimize the effects on stormwater. If the area will not be used for permanent roads, parking areas, or structures, a 6-inch depth of hog fuel may also be used, but this is likely to require more maintenance. Whenever possible, construction roads and parking areas shall be placed on a firm, compacted subgrade.• Temporary road gradients shall not exceed 15 percent. Roadways shall be carefully graded to drain. Drainage ditches shall be provided on each side of the roadway in the case of a crowned section, or on one side in the case of a super-elevated section. Drainage ditches shall be directed to a sediment control BMP.• Rather than relying on ditches, it may also be possible to grade the road so that runoff sheet-flows into a heavily vegetated area with a well-developed topsoil. Landscaped areas are not adequate. If this area has at least 50 feet of vegetation that water can flow through, then it is generally preferable to use the vegetation to treat runoff, rather than a sediment pond or trap. The 50 feet shall not include wetlands or their buffers. If runoff is allowed to sheetflow through adjacent vegetated areas, it is vital to design the roadways and parking areas so that no concentrated runoff is created.• Storm drain inlets shall be protected to prevent sediment-laden water entering the storm drain system (see BMP C220).
<i>Maintenance Standards</i>	Inspect stabilized areas regularly, especially after large storm events. Crushed rock, gravel base, etc. shall be added as required to maintain a

stable driving surface and to stabilize any areas that have eroded.

Following construction, these areas shall be restored to pre-construction condition or better to prevent future erosion.

Perform street cleaning at the end of each day or more often if necessary.

BMP C233: Silt Fence

Purpose Use of a silt fence reduces the transport of coarse sediment from a construction site by providing a temporary physical barrier to sediment and reducing the runoff velocities of overland flow. See [Figure 4.2.12](#) for details on silt fence construction.

Conditions of Use Silt fence may be used downslope of all disturbed areas.

- Silt fence shall prevent soil carried by runoff water from going beneath, through, or over the top of the silt fence, but shall allow the water to pass through the fence.
- Silt fence is not intended to treat concentrated flows, nor is it intended to treat substantial amounts of overland flow. Convey any concentrated flows through the drainage system to a sediment pond.
- Do not construct silt fences in streams or use in V-shaped ditches. Silt fences do not provide an adequate method of silt control for anything deeper than sheet or overland flow.

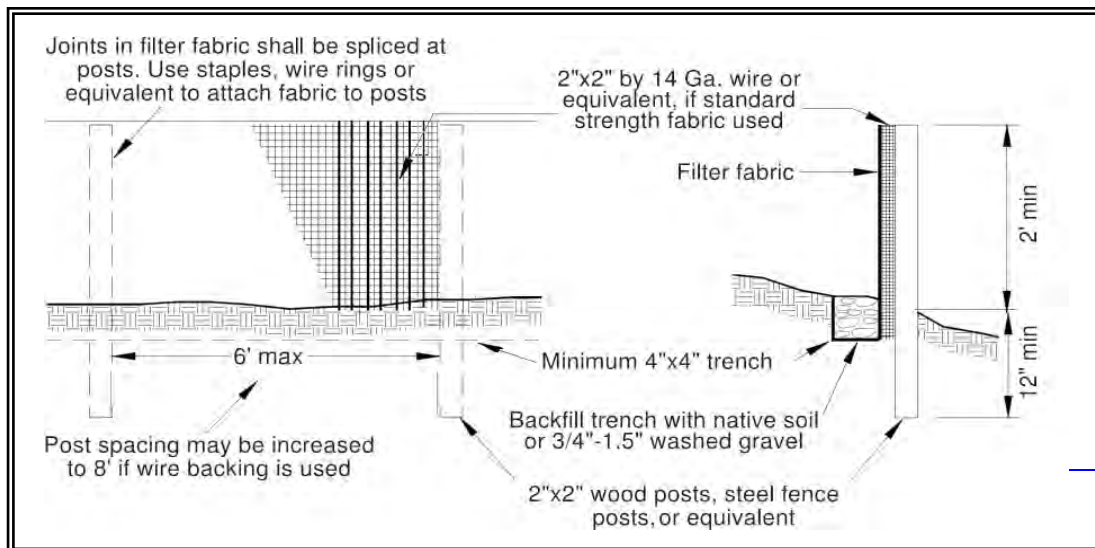

Figure 4.2.12 – Silt Fence

***Design and
Installation
Specifications***

- Use in combination with sediment basins or other BMPs.
- Maximum slope steepness (normal (perpendicular) to fence line) 1H:1V.
- Maximum sheet or overland flow path length to the fence of 100 feet.
- Do not allow flows greater than 0.5 cfs.
- The geotextile used shall meet the following standards. All geotextile properties listed below are minimum average roll values (i.e., the test result for any sampled roll in a lot shall meet or exceed the values shown in [Table 4.2.3](#)):

Table 4.2.3 Geotextile Standards	
Polymeric Mesh AOS (ASTM D4751)	0.60 mm maximum for slit film woven (#30 sieve). 0.30 mm maximum for all other geotextile types (#50 sieve). 0.15 mm minimum for all fabric types (#100 sieve).
Water Permittivity (ASTM D4491)	0.02 sec ⁻¹ minimum
Grab Tensile Strength (ASTM D4632)	180 lbs. Minimum for extra strength fabric. 100 lbs minimum for standard strength fabric.
Grab Tensile Strength (ASTM D4632)	30% maximum
Ultraviolet Resistance (ASTM D4355)	70% minimum

- Support standard strength fabrics with wire mesh, chicken wire, 2-inch x 2-inch wire, safety fence, or jute mesh to increase the strength of the fabric. Silt fence materials are available that have synthetic mesh backing attached.
- Filter fabric material shall contain ultraviolet ray inhibitors and stabilizers to provide a minimum of six months of expected usable construction life at a temperature range of 0°F. to 120°F.
- One-hundred percent biodegradable silt fence is available that is strong, long lasting, and can be left in place after the project is completed, if permitted by local regulations.

- Refer to [Figure 4.2.12](#) for standard silt fence details. Include the following standard Notes for silt fence on construction plans and specifications:
 1. The contractor shall install and maintain temporary silt fences at the locations shown in the Plans.
 2. Construct silt fences in areas of clearing, grading, or drainage prior to starting those activities.
 3. The silt fence shall have a 2-foot min. and a 2½-foot max. height above the original ground surface.
 4. The filter fabric shall be sewn together at the point of manufacture to form filter fabric lengths as required. Locate all sewn seams at support posts. Alternatively, two sections of silt fence can be overlapped, provided the Contractor can demonstrate, to the satisfaction of the Engineer, that the overlap is long enough and that the adjacent fence sections are close enough together to prevent silt laden water from escaping through the fence at the overlap.
 5. Attach the filter fabric on the up-slope side of the posts and secure with staples, wire, or in accordance with the manufacturer's recommendations. Attach the filter fabric to the posts in a manner that reduces the potential for tearing.
 6. Support the filter fabric with wire or plastic mesh, dependent on the properties of the geotextile selected for use. If wire or plastic mesh is used, fasten the mesh securely to the up-slope side of the posts with the filter fabric up-slope of the mesh.
 7. Mesh support, if used, shall consist of steel wire with a maximum mesh spacing of 2-inches, or a prefabricated polymeric mesh. The strength of the wire or polymeric mesh shall be equivalent to or greater than 180 lbs. grab tensile strength. The polymeric mesh must be as resistant to the same level of ultraviolet radiation as the filter fabric it supports.
 8. Bury the bottom of the filter fabric 4-inches min. below the ground surface. Backfill and tamp soil in place over the buried portion of the filter fabric, so that no flow can pass beneath the fence and scouring cannot occur. When wire or polymeric back-up support mesh is used, the wire or polymeric mesh shall extend into the ground 3-inches min.

9. Drive or place the fence posts into the ground 18-inches min. A 12-inch min. depth is allowed if topsoil or other soft subgrade soil is not present and 18-inches cannot be reached. Increase fence post min. depths by 6 inches if the fence is located on slopes of 3H:1V or steeper and the slope is perpendicular to the fence. If required post depths cannot be obtained, the posts shall be adequately secured by bracing or guying to prevent overturning of the fence due to sediment loading.
 10. Use wood, steel or equivalent posts. The spacing of the support posts shall be a maximum of 6-feet. Posts shall consist of either:
 - Wood with dimensions of 2-inches by 2-inches wide min. and a 3-foot min. length. Wood posts shall be free of defects such as knots, splits, or gouges.
 - No. 6 steel rebar or larger.
 - ASTM A 120 steel pipe with a minimum diameter of 1-inch.
 - U, T, L, or C shape steel posts with a minimum weight of 1.35 lbs./ft.
 - Other steel posts having equivalent strength and bending resistance to the post sizes listed above.
 11. Locate silt fences on contour as much as possible, except at the ends of the fence, where the fence shall be turned uphill such that the silt fence captures the runoff water and prevents water from flowing around the end of the fence.
 12. If the fence must cross contours, with the exception of the ends of the fence, place gravel check dams perpendicular to the back of the fence to minimize concentrated flow and erosion. The slope of the fence line where contours must be crossed shall not be steeper than 3H:1V.
 - Gravel check dams shall be approximately 1-foot deep at the back of the fence. Gravel check dams shall be continued perpendicular to the fence at the same elevation until the top of the check dam intercepts the ground surface behind the fence.
 - Gravel check dams shall consist of crushed surfacing base course, gravel backfill for walls, or shoulder ballast. Gravel check dams shall be located every 10 feet along the fence where the fence must cross contours.
- Refer to [Figure 4.2.13](#) for slicing method details. Silt fence installation using the slicing method specifications:

1. The base of both end posts must be at least 2- to 4-inches above the top of the filter fabric on the middle posts for ditch checks to drain properly. Use a hand level or string level, if necessary, to mark base points before installation.
2. Install posts 3- to 4-feet apart in critical retention areas and 6- to 7-feet apart in standard applications.
3. Install posts 24-inches deep on the downstream side of the silt fence, and as close as possible to the filter fabric, enabling posts to support the filter fabric from upstream water pressure.
4. Install posts with the nipples facing away from the filter fabric.
5. Attach the filter fabric to each post with three ties, all spaced within the top 8-inches of the filter fabric. Attach each tie diagonally 45 degrees through the filter fabric, with each puncture at least 1-inch vertically apart. Each tie should be positioned to hang on a post nipple when tightening to prevent sagging.
6. Wrap approximately 6-inches of fabric around the end posts and secure with 3 ties.
7. No more than 24-inches of a 36-inch filter fabric is allowed above ground level.

Compact the soil immediately next to the filter fabric with the front wheel of the tractor, skid steer, or roller exerting at least 60 pounds per square inch. Compact the upstream side first and then each side twice for a total of four trips. Check and correct the silt fence installation for any deviation before compaction. Use a flat-bladed shovel to tuck fabric deeper into the ground if necessary.

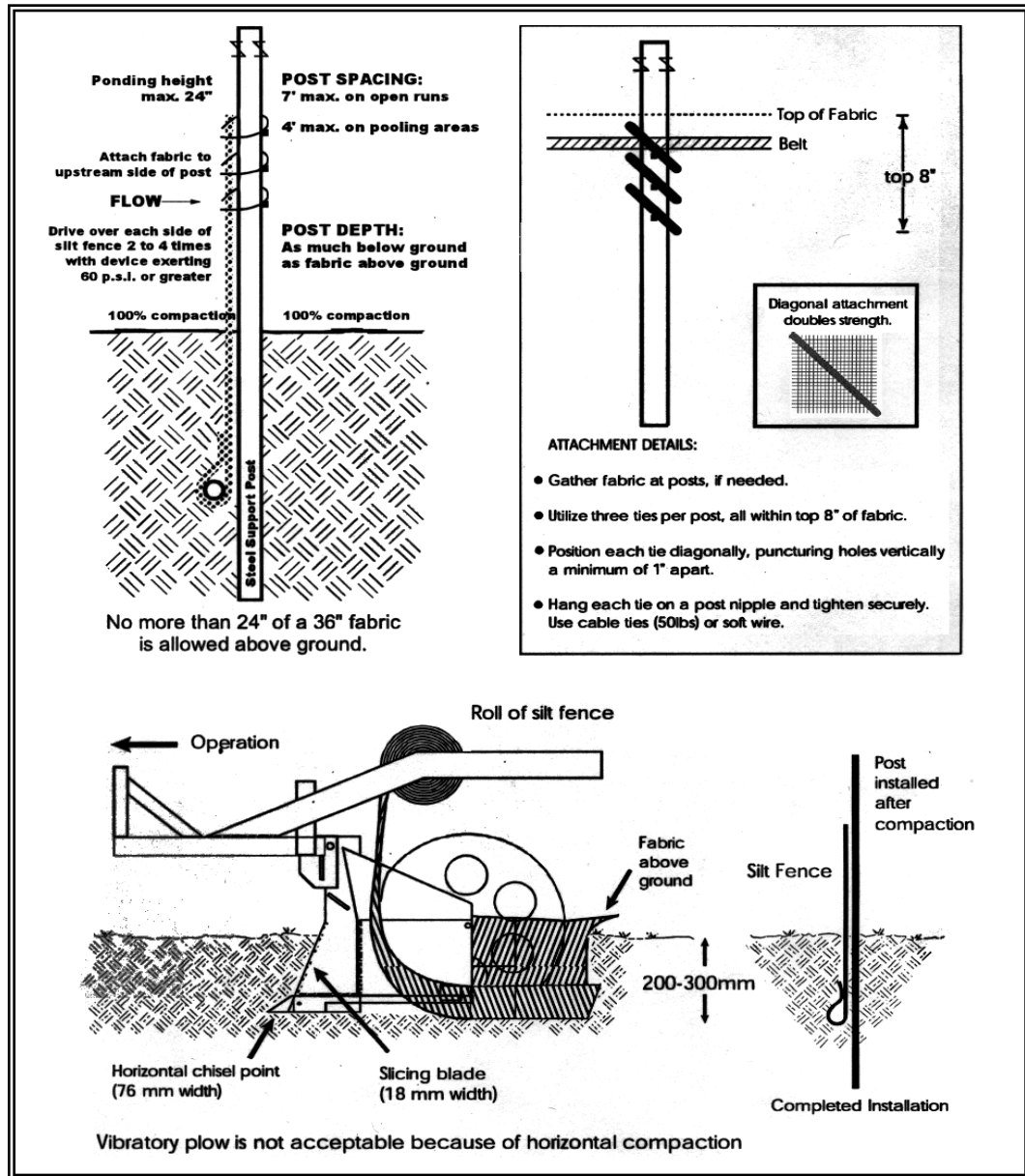

Figure 4.2.13 – Silt Fence Installation by Slicing Method

Maintenance Standards

- Repair any damage immediately.
- Intercept and convey all evident concentrated flows uphill of the silt fence to a sediment pond.
- Check the uphill side of the fence for signs of the fence clogging and acting as a barrier to flow and then causing channelization of flows parallel to the fence. If this occurs, replace the fence or remove the trapped sediment.
- Remove sediment deposits when the deposit reaches approximately one-third the height of the silt fence, or install a second silt fence.
- Replace filter fabric that has deteriorated due to ultraviolet breakdown.

BMP C235: Wattles

Purpose

Wattles are temporary erosion and sediment control barriers consisting of straw, compost, or other material that is wrapped in biodegradable tubular plastic or similar encasing material. They reduce the velocity and can spread the flow of rill and sheet runoff, and can capture and retain sediment. Wattles are typically 8 to 10 inches in diameter and 25 to 30 feet in length. Wattles are placed in shallow trenches and staked along the contour of disturbed or newly constructed slopes. See [Figure 4.2.14](#) for typical construction details. WSDOT Standard Plan I-30.30-00 also provides information on Wattles (<http://www.wsdot.wa.gov/Design/Standards/Plans.htm#SectionI>)

Conditions of Use

- Use wattles:
 - In disturbed areas that require immediate erosion protection.
 - On exposed soils during the period of short construction delays, or over winter months.
 - On slopes requiring stabilization until permanent vegetation can be established.
- The material used dictates the effectiveness period of the wattle. Generally, Wattles are typically effective for one to two seasons.
- Prevent rilling beneath wattles by properly entrenching and abutting wattles together to prevent water from passing between them.

Design Criteria

- Install wattles perpendicular to the flow direction and parallel to the slope contour.
- Narrow trenches should be dug across the slope on contour to a depth of 3- to 5-inches on clay soils and soils with gradual slopes. On loose soils, steep slopes, and areas with high rainfall, the trenches should be dug to a depth of 5- to 7- inches, or 1/2 to 2/3 of the thickness of the wattle.
- Start building trenches and installing wattles from the base of the slope and work up. Spread excavated material evenly along the uphill slope and compacted using hand tamping or other methods.
- Construct trenches at intervals of 10- to 25-feet depending on the steepness of the slope, soil type, and rainfall. The steeper the slope the closer together the trenches.
- Install the wattles snugly into the trenches and abut tightly end to end. Do not overlap the ends.
- Install stakes at each end of the wattle, and at 4-foot centers along entire length of wattle.

- If required, install pilot holes for the stakes using a straight bar to drive holes through the wattle and into the soil.
- Wooden stakes should be approximately 3/4 x 3/4 x 24 inches min. Willow cuttings or 3/8-inch rebar can also be used for stakes.
- Stakes should be driven through the middle of the wattle, leaving 2 to 3 inches of the stake protruding above the wattle.
- Wattles may require maintenance to ensure they are in contact with soil and thoroughly entrenched, especially after significant rainfall on steep sandy soils.
- Inspect the slope after significant storms and repair any areas where wattles are not tightly abutted or water has scoured beneath the wattles.

Maintenance Standards

Approved as Equivalent

Ecology has approved products as able to meet the requirements of [BMP C235](#). The products did not pass through the Technology Assessment Protocol – Ecology (TAPE) process. Local jurisdictions may choose not to accept this product approved as equivalent, or may require additional testing prior to consideration for local use. The products are available for review on Ecology’s website at <http://www.ecy.wa.gov/programs/wq/stormwater/newtech/equivalent.html>

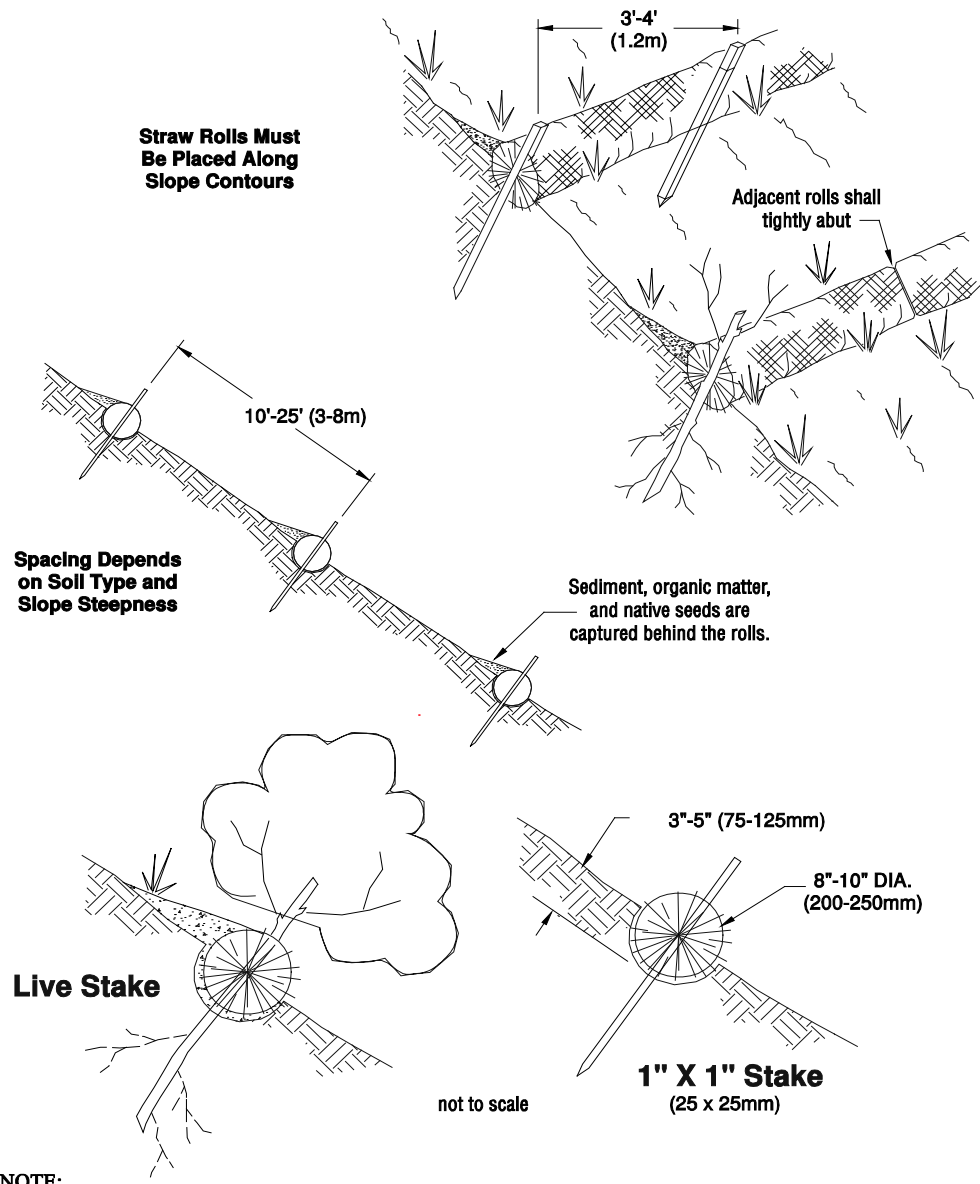

NOTE:
 1. Straw roll installation requires the placement and secure staking of the roll in a trench, 3"-5" (75-125mm) deep, dug on contour. runoff must not be allowed to run under or around roll.

Figure 4.2.14 – Wattles

Appendix D – Site Inspection Forms (and Site Log)

Stormwater/Erosion Control Inspection Form									
DATE:			TIME:			CONTACT:			
SITE:			ACRES:						
LOCATION:									
WEATHER:									
PERMIT ON SITE			PERMIT NO.						
SWPPP ON SITE			CONTRACTOR:						
Best Management Practices in the SWPPP:									
Control BMPs	In Plan	Properly installed	Treatment BMPs	In Plan	Properly Installed	Other:			
Preserv Nat Veg			Intercept Dike/Swale						
Buffer Zones			Grass Lines Swales						
High Vis Fence			Channel Lining						
Stake & Wire Fence			Water bars						
Stabilized Entrance			Pipe Slope Drains						
Wheel Wash			Subsurface Drains						
Road/Pk Area Stable			Level Spreader						
Temp/Perm Seeding			Check Dams						
Mulching			Triangular Silt Dike						
Nets/Blankets			Outlet Protection						
Plastic Covering			Sto Drain Inlet Protec						
Sodding			Straw Bale Barrier						
Topsoiling			Brush Barrier						
Polyacrylamides			Gravel Filter Berm						
Surface roughing			Silt Fence						
Gradient Terraces			Vegetated Strip						
Dust Control			Straw Wattles						
Materials On Hand			Sediment trap						
Concrete Handling			Temp Sed Pond						
Sawcut & Surface			SW Chem Treatment						
Erosion Control Lead			SW Filtration						
Pay Erosion Work			Is the site stabilized?		Partially				
Scheduling			Turbid Water is being discharged?						
Small Project			Receiving Water:						
Water Quality Samples Taken?			Results:	pH	TUR	CON	TEM	Other:	
Sample ID:			LOC:						
Sample ID:			LOC:						
Sample ID:			LOC:						
This site is IN/OUT of compliance with the terms of the SWPPP & Permit.									
Summary of remedial action(if needed):									
<i>I certify under penalty of law that this report is true, accurate and complete, to the best of my knowledge and belief.</i>									
Name:			Title:						
Signature:									

**APPENDIX C –
TACOMA-PIERCE COUNTY
HEALTH DEPARTMENT -
WASTE DISPOSAL
AUTHORIZATION**



No. 1843

Tacoma - Pierce County
Health Department
Healthy People in Healthy Communities
www.tpchd.org

WASTE DISPOSAL AUTHORIZATION

Tacoma Pierce County
Health Department

- Non-Asbestos New
- Asbestos (PSCAA Case # _____) Amendment

11/21/2014 9:39:26 AM
 Clerk 53-T5
 Waste Disposal Auth Initial
 \$145.00
 Receipt #360994
 ck200155 Port of Tac 1101 Por

- A. Generator Name: Port of Tacoma – Pier 4
- B. Generator Address: 1101 Port of Tacoma Road, Pier 4, Tacoma, WA
- C. Transporter Name: To Be Determined
- D. Technical Contact: Scott Hooten, Port of Tacoma Phone: (253)383-9428
- E. Waste Description: Contaminated Dredge Sediments - Port of Tacoma Pier 4 on the Blair Waterway
 Sludge Solid PCS Other
- F. Approved Quantity: 80,000 Tons (~50,000 Yds³)
- G. Actual Quantity (Filled in upon disposal): _____
- H. Multiple Loads: Yes No
- I. Dates of Disposal: January 1, 2015 through December 31, 2015
- J. Testing: LPAH, HPAH, Dioxins/Furans, Pesticides, Metals (including Tributyltin), PCB's, Phenols, VOC's
- K. Reviewed by Department of Ecology: Yes No
- L. Disposal/Transportation Requirements: **A copy of this WDA must be transported with EACH load of waste and presented to the LRI Landfill Scalehouse Operator. These sediments qualify for management as a Special Waste per WAC 173-303-073, Conditional Exclusion of Special Wastes. As such, sediments are suitable for disposal in a MSWLF permitted in accordance with Chapter 173-351 WAC. Sediments are currently authorized for disposal only, unless LRI can demonstrate to the satisfaction of the TPCHD that the sediments physical characteristics are suitable for use as an ADC. Sediments shall be sufficiently dewatered such that they pass the Paint Filter Test prior to transport. In the event that liquids separate during transportation, the trucks must contain 100% of the liquids within the transportation vehicle. No leakage or spillage during transportation is acceptable and may result in revocation of this WDA. Load sizes shall comply with conditional-use and solid waste permit criteria.**
- M. Facility: LRI Landfill (304th Street LF), 30919 Meridian Street, Eatonville, WA

CERTIFICATION

I hereby certify that I have personally examined and am familiar with the information submitted in this document and any supporting material. Based on my inquiry of those individuals immediately responsible for obtaining the information, the information submitted is true, accurate and complete to the best of my knowledge and ability and that all known and suspected hazards have been disclosed. I agree that the generator and/or transporter will abide by all conditions specified in line (L) or any attachments thereto.

11/21/14 ENV. PROGRAMS ANALYST [Signature]
 Date Title Signature

AUTHORIZED BY:

[Signature]
 Andy Comstock, TPCHD (253)798-6538

APPROVED

OCT 29 2014

TACOMA-PIERCE COUNTY HEALTH DEPT.
ENVIRONMENTAL HEALTH DIV.
 For Official Use Only

Cc: LRI LF Scalehouse via Fax – 253 875 7205

**APPENDIX D –
DREDGED MATERIAL
MANAGEMENT PROGRAM
(DMMP) SUITABILITY
DETERMINATION, DATED
JANUARY 8, 2015**

MEMORANDUM FOR: RECORD

January 8, 2015

SUBJECT: DETERMINATION REGARDING THE SUITABILITY OF PROPOSED DREDGED MATERIAL FROM PHASE 1 OF THE PORT OF TACOMA PIER 4 CLEANUP AND RECONFIGURATION PROJECT EVALUATED FOR UNCONFINED OPEN-WATER DISPOSAL AT THE COMMENCEMENT BAY DISPOSAL SITE OR BENEFICIAL USE

1. **Introduction.** This memorandum reflects the consensus determination of the Dredged Material Management Program (DMMP) agencies (U.S. Army Corps of Engineers, Washington State Department of Ecology, Washington State Department of Natural Resources, and the U.S. Environmental Protection Agency) regarding the suitability of up to 11,300 cubic yards (cy) of dredged material from Phase 1 of the Port of Tacoma's Pier 4 Cleanup and Reconfiguration project for open-water disposal at the Commencement Bay nondispersive site or for beneficial use, and for compliance with the State of Washington Antidegradation Policy.
2. **Background.** In early 2013 the Port of Tacoma proposed dredging of approximately 550,000 cy of material to cutback and reconfigure Pier 4 to be in alignment with Pier 3 within Husky Container Terminal on the Blair Waterway (see Figure 1 for project location and extent). During sediment sampling in April 2013 for characterization of the proposed dredged material, levels of porewater tributyltin (TBT) were found in the in-water DMMU A exceeding the DMMP screening level (SL) for porewater TBT of 0.15 µg/L. Subsequent sampling events in August and November 2013 to determine the extent of TBT contamination revealed very high levels of TBT in bulk sediment analysis, up to 50,000 µg/kg, nearly three orders of magnitude above the DMMP bulk TBT SL of 73 µg/kg.

A fourth sampling event in July 2014 was conducted under an Agreed Order on Consent (AOC) between the Environmental Protection Agency (USEPA) and the Port of Tacoma to determine the vertical and horizontal extent of TBT contamination at Pier 4. Following review of the preliminary results of the July sampling event, USEPA determined that the cleanup of the TBT-contaminated sediments was to proceed as a Time Critical Removal Action. Therefore, the work occurring at Pier 4 will have two distinct work phases: (1) the Phase 1 Removal Action, which includes a USEPA-ordered cleanup of contaminated sediment, and (2) the Phase 2 Reconfiguration Project, which includes reconfiguration of the existing pier. A brief description of the work associated with each phase of the project follows:

Phase 1

Removal of approximately 49,000 cy of TBT-contaminated sediment will be removed under an AOC between the Port of Tacoma and USEPA (Floyd|Snider, 2014). Prior to removal of the contaminated material along the slope and at the pier face, the upper portion of the slope must be removed to maintain slope stability. This suitability determination applies only to the 11,300 cy of top-of-slope dredged material, see Figure 2.

Phase 2

Following the removal of the 49,000 cy of TBT-contaminated sediments, the Port will continue work to cutback Pier 4 to be in alignment with Pier 3. This work, which will include dredging of approximately 500,000 cy of material, is subject to review and permitting under Section 404 of the Clean Water Act, and will receive a separate suitability determination from the DMMP agencies at a future date.

3. **Project Summary.** Table 1 includes project summary and tracking information.

Table 1. Project Summary

Project ranking	High
Proposed dredging volume	11,300 cy
Proposed dredging depth	Upslope from -2 ft MLLW, with a depth of 8,9, or 11 ft. (plus 1 ft of overdepth) in the southern, northern, and middle sections, respectively
Sampling dates	April 11-19, 2013
	August 8-9, 2013
	November 13-16, 2013
	June 30 - July 9, 2014
Draft suitability memo	September 18, 2014
Comments provided on draft suitability memo	October 6, 2014
Second draft suitability memo	November 13, 2014
Comments provided on 2 nd draft memo	December 1, 2014
Third draft suitability memo	December 5, 2014
Comments on 3 rd draft suitability memo	December 17, 2014
Final suitability memo received	December 22, 2014
EIM Study ID	POTP413
Recency Determination (high rank = 3 years)	July 2017

4. **Project Ranking and Sampling Requirements.** This project was originally ranked moderate by the DMMP agencies according to a review of previous testing results and the guidelines set out in the DMMP User Manual for areas on the Blair Waterway (DMMP, 2013). However, as a result of the extremely high levels of TBT found in the sediments along Pier 4, the area is now considered a high ranked area.

In a high-ranked area the number of samples and analyses are calculated using the following guidelines (DMMP, 2013):

- Maximum volume of sediment represented by each field sample = 4,000 cubic yards
- Maximum volume of sediment represented by each analysis in the upper 4-feet of the dredging prism (surface sediment) = 4,000 cubic yards

- Maximum volume of sediment represented by each analysis in the subsurface portion of the dredging prism = 12,000 cubic yards

Samples representing the proposed dredged material were collected over several sampling events as described in section 5 below and in detail in the Pier 4 Phase 2 Reconfiguration Project Sediment Characterization Report (Floyd|Snider, 2014a). Nevertheless, the total number of samples collected from within the proposed dredge footprint is sufficient to meet the DMMP requirements for a high ranked project. Five samples were collected from within the dredge prism and were analyzed individually to represent the 11,300 cy of material. See Table 2 for sample locations and Table 3 for collection dates, type of equipment used, mudline elevations and sample intervals collected for each bore.

5. **Sampling.** As mentioned above, sampling over the entire project area took place over four events between April 2013 and July 2014. A detailed description of the activities and results from each sampling event can be found in the Pier 4 Phase 2 Reconfiguration Project Sediment Characterization Report (Floyd|Snider, 2014a). Figure 4.1 includes all the results from all sampling events.

The sample locations considered in this suitability determination are shown in Figures 2 & 3 and are summarized below:

- In April 2013 samples C1 and C2 were collected to represent the upland cutback material by direct push boring. Both of these samples were collected in 4 foot intervals from the surface to 20 feet depth and composited together to represent surface DMMU P4-C1 and subsurface DMMUs P4-C2 and P4-C3.
- In November 2013 sample locations A12 and A14 were collected by roto-sonic boring after cutting a hole in the deck of the pier. This method of sampling was used in order to penetrate the rip rap slope armoring on the surface beneath the pier.
- In July 2014 a final sampling event took place as part of a site removal action evaluation under an AOC between USEPA and the Port. During this sampling event samples A18, B14 and B15 were collected by roto-sonic boring and samples C3, C4 and C5 were collected by direct-push soil boring.

All upland soil borings were advanced by Cascade Drilling of Woodinville, WA and collected in 4 or 5 foot intervals using a direct-push Geoprobe equipped with a disposable sample tube liner. All samples were photographed and documented on field boring log forms using the Unified Soil Classification System (USCS). A dark gray fine sand unit with red and white grains and occasional shell and wood fragments was assumed to be native material.

All under-pier roto-sonic sediment borings were advanced by Holt Services, Inc. of Edgewood, WA. Roto-sonic drilling uses resonant sonic energy to exploit weaknesses in hard materials such as rip rap, allowing collection of the sediment beneath the armored under-pier slope. Samples were collected continuously from the steel casing within the drill rods, which were lined with disposable polyethylene liners. All sample units and material types encountered were photographed and documented on a boring log form according to the USCS.

At the three under-pier locations representing the clean dredged material (A18, B14, and B15), sample recovery was poor due to the difficulty of sampling through the rock armor. At two of these three locations the surface sediment interval (immediately beneath the rip rap layer) could not be collected. As explained in the Sediment Characterization Report, "At under-pier Sampling Locations A18 and B15, the presence of surface riprap prevented sediments located within and underlying the riprap from being recovered and sampled because the sediments were not dense enough to push the riprap up through the core barrel. However, the surface intervals were able to be recovered at under-pier Sampling Location B14 because a large piece of riprap at 3 feet prevented further downward movement of the core barrel. The driller was able to pull up the core barrel with the top 3 feet of rock and intermixed sediment that was intact and the material was sampled. This differed from Sampling Locations A18 and B15 in that the riprap completely plugged the core barrel, preventing any additional material from being captured and retained. Samples were collected at approximately 2-foot intervals where sediment was recovered below the riprap slope armor." (Floyd|Snider, 2014)

6. **Chemical Analysis.** Analysis of conventionals, standard DMMP COCs and both bulk and porewater TBT was conducted by Analytical Resources, Inc. of Tukwila, WA.

The conventional results from composited upland DMMU C showed that the dredged material is predominantly sand with 64-93% percent sand, 4-14% percent silt and 0.4-2.6% percent clay. Total organic carbon (TOC) was 0.12-0.285 % in the composited DMMU. Results from individual under-pier boring locations show that the proposed dredged material is predominantly gravel in the upper sections and predominantly sand in the deeper intervals. TOC was highest at the surface at location C3 and C4 and quickly dropped at depth. See Table 6 for TOC and grain size results.

Results of the initial April 2013 sampling found that the only COC present in the project area was TBT. All other DMMP COCs in all upland and in-water sample locations were below DMMP screening levels (SLs). Sample locations C1 and C2, composited to represent DMMU C, are upland from the proposed dredged material, but are the closest samples to the dredge prism with analysis of the full DMMP suite of chemicals. Results from DMMU C are presented in Tables 4 and 5. Dioxin results for DMMU C were lower than the DMMP site management objective of 4 ppt TEQ (DMMP, 2010), as were dioxin results for all composited DMMUs (Floyd|Snider, 2014a). Based on these results it was determined that subsequent sampling events would only analyze for TBT.

TBT results are presented in Table 6. All samples collected from within the proposed dredge prism (A18, B14, B15, C4 and C5) are below the DMMP SL of 73 µg/kg and the majority of those results were undetected. In addition, results from A12 and A14, downslope of the proposed dredge prism and from C3, landward of the proposed dredge prism, were all less than the DMMP SL.

7. **Rock Armoring.** There is a 2 foot layer (2,300 cy) of approximately 18" rip rap armoring the slope within the proposed dredge prism. As outlined in the DMMP User Manual (DMMP, 2014) disposal of debris is not allowed at DMMP disposal sites. This includes all floatable debris and large non-floatable debris such as logs, piling, rip-rap and concrete.

Therefore, following pier demolition, the rip rap layer (2,300 cy) will be removed for reuse or upland disposal. Only then will the underlying 9,000 cy of clean material be dredged.

8. **Dredging Residuals.** Prior to dredging the majority of Pier 4 will be demolished and removed along with the supporting piles. In total, approximately 1,047 concrete piles, 87 creosote-treated timber piles and 22 steel piles will be removed by vibratory pile extraction, including the removal of piles from within the areas of highest TBT contamination.

The DMMP agencies expressed concern over the possibility that contaminated sediment could be suspended during pile extraction and deposited over the area of proposed clean dredged material at the top of the slope. To address these concerns, Floyd|Snider provided the following lines of evidence supporting the conclusion that pile removal is unlikely to affect clean top of slope sediments:

- The proposed Phase 1 clean dredged material will remain isolated from pier removal influences and any potential resuspension due to an overlying 2 foot layer of rip rap. Following pier demolition, the rip rap layer (2,300 cy) will be removed for reuse or upland disposal. Only then will the underlying 9,000 cy of clean material be dredged.
- Vibratory pile extraction shears sediment from the sides of the piles, resulting in very little sediment remaining attached to the pile, thereby reducing the amount of sediment available to be resuspended and deposited on the top of slope sediments.
- No sediment cover was found on the rock armoring within the top 30% of the slope, indicating that during normal tide cycles and operating conditions at Pier 4 resuspended sediment does not travel up slope far enough to reach the proposed dredge prism.
- The estimated the worst case scenario of how much contaminated sediment could be resuspended and deposited on the top-of slope clean material results in TBT concentrations in the top 1-ft of material that are less than the TBT SL. The details of these calculations, including all assumptions, can be found in Appendix A: Proposed Suitability of the Pier 4 Phase 1 Removal Action Project Clean Material Memo.

Therefore, based on these lines of evidence, the DMMP agencies determined using best professional judgment that the proposed dredged material is not likely to be contaminated during pile extraction.

9. **Sediment Exposed by Dredging.** The sediment to be exposed by dredging must either meet the State of Washington Sediment Quality Standards (SQS) or the State's Antidegradation standard (Ecology, 2013) as outlined by DMMP guidance (DMMP, 2008).

A first tier evaluation of antidegradation is to compare the dredged material to the DMMP Marine guidelines. As demonstrated by the results of the above analyses, the chemical concentrations in the project dredged material at the depth of the new exposed surface are below DMMP SLs. Therefore the sediment to be exposed by dredging is not considered to be degraded relative to the currently exposed sediment surface.

Note, the sediment that will be exposed after dredging of the Phase 1 top-of-slope clean material will only be exposed to the environment for a limited time. The final exposed surface will be the surface that remains after the completion of Phase 2 dredging. The antidegradation status of the final exposed surface will be evaluated in the forthcoming DMMP suitability determination for Phase 2 of the Port of Tacoma Pier 4 Reconfiguration Project.

10. **Suitability Determination.** This memorandum documents the evaluation of the suitability of sediment proposed for dredging from Phase 1 of the Port of Tacoma Pier 4 cleanup and reconfiguration project for unconfined open-water disposal at the Commencement Bay site. The approved sampling and analysis plans were followed and the data gathered were deemed sufficient and acceptable for regulatory decision-making under the DMMP program.

In summary, based on the results of the previously described testing, the DMMP agencies conclude that **up to 9,000 cy of dredged material from Phase 1 of the Port of Tacoma's Pier 4 cleanup are suitable** for open-water disposal at the Commencement Bay non-dispersive disposal site or for beneficial use. **Approximately 2,300 cy of riprap from the top two feet of the dredge prism is unsuitable** for open-water disposal, and must be disposed of in an approved manner. After removal of the top two feet of rip rap, any incidental rip rap mixed with sediment within the dredged material will be allowed to be disposed of at the Commencement Bay disposal site as long as the rip rap is less than 2' x 2'. Sorting of dredged material through a mesh screen may be required.

A determination regarding the suitability of material for upland disposal must be coordinated with the local Health Department.

*This suitability determination does **not** constitute final agency approval of the project. A pre-dredge meeting with DNR, Ecology, EPA and the Corps of Engineers is required at least 7 days prior to dredging. A dredging quality control plan must be developed and submitted to the Agencies at least 7 days prior to the pre-dredge meeting. A DNR site use authorization must also be acquired.*

11. **References.**

DMMP, 2014. *Dredged Material Evaluation and Disposal Procedures (Users Manual)*. Prepared by the Seattle District Dredged Material Management Office for the Dredged Material Management Program, December 2014.

DMMP, 2010. *Dredged Material Management Program New Interim Guidelines for Dioxins*. December 6, 2010.

DMMP, 2008. *Quality of Post-Dredge Sediment Surfaces (Updated)*. A Clarification Paper Prepared by David Fox (USACE), Erika Hoffman (EPA) and Tom Gries (Ecology) for the Dredged Material Management Program, June 2008.

Ecology, 2013. *Sediment Management Standards – Chapter 173-204 WAC*. Washington State Department of Ecology, February 2013.

Floyd|Snider, 2014a. Pier 4 Phase 2 Reconfiguration Project Sediment Characterization Report. Prepared for the Port of Tacoma by Floyd|Snider. November 24, 2014.

Floyd|Snider, 2014b. Memorandum regarding the Proposed Suitability of the Pier 4 Phase 1 Removal Action Project Clean Material. December 22, 2014.

12. Agency Signatures.

Concur:

1/8/2015
Date

Kelsey van der Elst - Seattle District Corps of Engineers

1-8-15
Date

Justine Barton - Environmental Protection Agency

1-8-15
Date

Erika Hoffman - Environmental Protection Agency

01/09/2015
Date

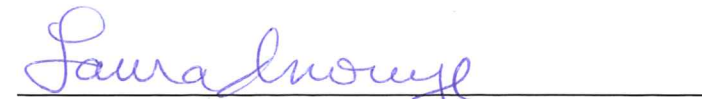
Laura Inouye, Ph.D. - Washington Department of Ecology

1/8/15
Date

Celia Barton - Washington Department of Natural Resources

Copies furnished:

DMMP signatories

Jessi Massingale, Floyd|Snider

Erin Murray, Floyd|Snider

Scott Hooton, Port of Tacoma

Trevor Thornsley, Port of Tacoma

Table 2. Sample Locations and Collection Information

Station	Coordinates		Mudline elevation (ft MLLW)	Total length of boring (ft)	Total Project Volume (CY)
	Northing	Easting			
A18	713043.0	1166941.389	-2	0-13	11,300
B14	712954.5	1167089.387	-3	0-10	
B15	712850.6	1167263.0	-2.2	0-15.5	
C4	712918.3	1167068.0	17	0-6	
C5	712813.5	1167243.223	17	0-6	
A12	713261.5	1166701.1	-30.6	0-10	
A14	713236.2	1166689.1	-17.6	0-5	
C1	712933.8	1166950.1	17	0-20	
C2	712728.3	1167258.7	17	0-20	
C3	712995.6	1166897.699	17	0-6	

Notes:

Coordinates are in Washington State Plane S, US Feet.

Table 3. Sampling Date, Equipment and Sample Intervals Collected

Station	Sampling Date	Sample type	Mudline elevation (ft MLLW)	Bore intervals collected
A12	November 2013	Roto-sonic boring	-30.6	1.5 - 3
				3-5
				9-10
A14			-17.6	2-4
				4-5
A18			-2	7-9
				9-10
				11-13
B14	July 2014	Roto-sonic boring	-3	0-2
				2-3
				8-10
B15			-2.2	9-10
				11.5-13.5
				13.5-15.5
C1	April 2013	Direct push boring - composited into DMMU C	17	0-4
				4-8
				8-12
				12-16
				16-20
C2			17	0-4
				4-8
				8-12
				12-16
				16-20
C3			17	0-2
				2-4
				4-6
C4	July 2014	Direct push boring	17	0-2
				2-4
				4-6
C5			17	0-2
				2-4
				4-6

Table 4. Chemical results compared to DMMP regulatory guidelines.

CHEMICAL	DMMP Guidelines			P4-C1 0-4 ft		P4-C2 4-8 ft		P4-C3 8-12 ft	
	SL	BT	ML	conc	LQ	conc	LQ	conc	LQ
CONVENTIONALS									
Gravel, %				18.8		1.6		1.6	
Sand, %				64.4		89.9		93.3	
Silt, %				14.2		7.9		4.2	
Clay, %				2.6		0.4		1	
Fines (Silt + Clay), %				16.8		8.4		5.1	
Total Solids, %				92.4		94.55		86.8	
Volatile Solids, %				1.18		0.88		0.84	
Total Organic Carbon, %				0.136		0.136		0.12	
Total Sulfides, mg/kg				1.53	J	2.17	J	1.08	UJ
Total Ammonia, mg N/kg				0.1	U	0.1	U	0.11	U
METALS (mg/kg dry)									
Antimony	150	---	200	5	UJ	5	UJ	6	UJ
Arsenic	57	507	700	5	U	5	U	6	U
Cadmium	5.1	11.3	14.0	0.4		0.3		0.3	
Chromium	260	260	---	15.7		12.2		11.2	
Copper	390	1,027	1,300	13.4		10.9		9.8	
Lead	450	975	1,200	4		2	U	2	U
Mercury	0.41	1.5	2.3	0.02	U	0.02	U	0.02	U
Selenium	---	3	---	0.5	U	0.5	U	0.6	U
Silver	6.1	6.1	8.4	0.3	U	0.3	U	0.3	U
Zinc	410	2,783	3,800	22		22		18	
ORGANOMETALLIC COMPOUNDS (ug/kg)									
Tributyltin (bulk)	0.15	0.15	---	3.4	U	3	U	3.2	U
PAHs (ug/kg dry)									
Total LPAH	5,200	---	29,000	19	U	19	U	18	U
Naphthalene	2,100	---	2,400	19	U	19	U	18	U
Acenaphthylene	560	---	1,300	19	U	19	U	18	U
Acenaphthene	500	---	2,000	19	U	19	U	18	U
Fluorene	540	---	3,600	19	U	19	U	18	U
Phenanthrene	1,500	---	21,000	19	U	19	U	18	U
Anthracene	960	---	13,000	19	U	19	U	18	U
2-Methylnaphthalene	670	---	1,900	19	U	19	U	18	U
Total HPAH	12,000	---	69,000	21	J	37	U	36	U
Fluoranthene	1,700	4,600	30,000	19	U	19	U	18	U
Pyrene	2,600	11,980	16,000	9.7	JQ	19	U	18	U
Benzo(a)anthracene	1,300	---	5,100	11	JQ	37	U	36	U
Chrysene	1,400	---	21,000	19	U	19	U	18	U
Total benzofluoranthenes	3,200	---	9,900	19	U	19	U	18	U
Benzo[a]pyrene	1,600	---	3,600	4.8	U	4.6	U	4.5	U
Indeno(1,2,3-c,d)pyrene	600	---	4,400	19	U	19	U	18	U
Dibenzo(a,h)anthracene	230	---	1,900	19	U	19	U	18	U
Benzo(g,h,i)perylene	670	---	3,200	19	U	19	U	18	U
CHLORINATED BENZENES (ug/kg dry)									
1,2-Dichlorobenzene	35	---	110	4.8	U	4.6	U	4.5	U
1,4-Dichlorobenzene	110	---	120	4.8	U	4.6	U	4.5	U
1,2,4-Trichlorobenzene	31	---	64	4.8	U	4.6	U	4.5	U
Hexachlorobenzene	22	168	230	0.92	U	0.94	U	0.95	U

CHEMICAL	DMMP Guidelines			P4-C1 0-4 ft		P4-C2 4-8 ft		P4-C3 8-12 ft	
	SL	BT	ML						
PHTHALATE ESTERS (ug/kg dry)									
Dimethyl phthalate	71	---	1,400	4.8	U	4.6	U	4.5	U
Diethyl phthalate	200	---	1,200	48	U	46	U	45	U
Di-n-butyl phthalate	1,400	---	5,100	19	U	19	U	18	U
Butyl benzyl phthalate	63	---	970	4.8	U	4.6	U	4.5	U
Bis(2-ethylhexyl)phthalate	1,300	---	8,300	24	U	14	JQ	22	U
Di-n-octyl phthalate	6,200	---	6,200	19	U	19	U	18	U
PHENOLS (ug/kg dry)									
Phenol	420	---	1,200	19	U	19	U	18	UJ
2 Methylphenol	63	---	77	4.8	U	4.6	U	4.5	UJ
4 Methylphenol	670	---	3,600	19	U	19	U	18	UJ
2,4-Dimethylphenol	29	---	210	19	U	19	U	18	J
Pentachlorophenol	400	504	690	48	UJ	46	UJ	45	UJ
MISCELLANEOUS EXTRACTABLES (ug/kg dry)									
Benzoic acid	650	---	760	390	U	370	U	360	UJ
Benzyl alcohol	57	---	870	19	U	19	U	18	U
Dibenzofuran	540	---	1,700	19	U	19	U	18	U
Hexachlorobutadiene	11	---	270	0.92	U	0.94	U	0.95	U
Hexachloroethane	---	---	---	19	U	19	U	18	U
N-Nitrosodiphenylamine	28	---	130	19	U	19	U	18	U
PESTICIDES (ug/kg dry)									
Aldrin	10	---	---	0.46	U	0.47	U	0.47	U
Total Chlordane	3	37	---	0.46	U	0.47	U	0.47	U
Dieldrin	2	---	---	0.92	U	0.94	U	0.95	U
Heptachlor	2	---	---	0.46	U	0.47	U	0.47	U
p,p'-DDE	9	---	---	0.92	U	0.94	U	0.95	U
p,p'-DDD	16	---	---	0.92	U	0.94	U	0.95	U
p,p'-DDT	5	---	---	0.92	U	0.94	U	0.95	U
Total DDT		50	69	0.92	U	0.94	U	0.95	U
PCBs (ug/kg dry)									
Total PCBs	130	---	3,100	3.8	U	3.7	U	3.7	U
Total PCBs (mg/kg OC)	---	38	---	na		na		na	

J = estimated concentration

U = undetected

OC = organic carbon

SL = screening level

BT = bioaccumulation trigger

ML = maximum level

na = TOC outside the range of 0.5 - 2% used for carbon normalization

Table 5. Dioxin Results from composited DMMU C

CHEMICAL	TEF	P4-C1 0-4 ft				P4-C2 4-8 ft				P4-C3 8-12 ft			
		conc	VQ	TEQ (U = 0)	TEQ (U = 1/2 RL)	conc	VQ	TEQ (U = 0)	TEQ (U = 1/2 RL)	conc	VQ	TEQ (U = 0)	TEQ (U = 1/2 RL)
DIOXINS/FURANS													
2,3,7,8-TCDD	1	0.168	U	0	0.084	0.152	U	0	0.076	0.0279	U	0	0.01395
1,2,3,7,8-PeCDD	1	0.737	J	0.737	0.737	0.0819	U	0	0.04095	0.0739	U	0	0.03695
1,2,3,4,7,8-HxCDD	0.1	0.707	J	0.0707	0.0707	0.0899	J	0.00899	0.00899	0.0439	U	0	0.002195
1,2,3,6,7,8-HxCDD	0.1	1.88		0.188	0.188	0.244	J	0.0244	0.0244	0.194	U	0	0.0097
1,2,3,7,8,9-HxCDD	0.1	1.32		0.132	0.132	0.174	J	0.0174	0.0174	0.0699	U	0	0.003495
1,2,3,4,6,7,8-HpCDD	0.01	35.2		0.352	0.352	4.26	U	0	0.0213	3.79	U	0	0.01895
OCDD	0.0003	321		0.0963	0.0963	42.5	U	0	0.006375	41.9	U	0	0.006285
2,3,7,8-TCDF	0.1	0.42	U	0	0.021	0.0779	U	0	0.003895	0.0659	U	0	0.003295
1,2,3,7,8-PeCDF	0.03	0.402	U	0	0.00603	0.0819	U	0	0.0012285	0.0559	J	0.001677	0.001677
2,3,4,7,8-PeCDF	0.3	0.384	J	0.1152	0.1152	0.0639	U	0	0.009585	0.0339	U	0	0.005085
1,2,3,4,7,8-HxCDF	0.1	1.01		0.101	0.101	0.176	J	0.0176	0.0176	0.12	J	0.012	0.012
2,3,4,6,7,8-HxCDF	0.1	0.763	J	0.0763	0.0763	0.0619	U	0	0.003095	0.0499	U	0	0.002495
1,2,3,7,8,9-HxCDF	0.1	0.332	U	0	0.0166	0.0579	U	0	0.002895	0.0619	U	0	0.003095
1,2,3,4,6,7,8-HpCDF	0.01	7.5		0.075	0.075	0.977	J	0.00977	0.00977	1.27		0.0127	0.0127
1,2,3,6,7,8-HxCDF	0.1	0.503	J	0.0503	0.0503	0.0779	U	0	0.003895	0.0419	U	0	0.002095
1,2,3,4,7,8,9-HpCDF	0.01	0.681	U	0	0.003405	0.0799	U	0	0.0003995	0.0818	U	0	0.000409
OCDF	0.0003	17	U	0	0.00255	2.33	U	0	0.0003495	2.78	U	0	0.000417
TOTAL TEQ				1.994	2.127			0.078	0.248			0.026	0.135

Table 6. TBT and grain size results.

Station	Mudline elevation (ft MLLW)	Core intervals collected	Tributyltin (bulk; µg/kg)		Total Organic Carbon (%)		% Gravel		% Sand		% Silt		% Clay	
			Result	VQ	Result	VQ	Result	VQ	Result	VQ	Result	VQ	Result	VQ
A12	-30.6	1.5 - 3	8.4		0.605		55.9		30.2		9.8		4.1	
		3-5	3.4		0.474		1.2		72.6		20		6	
		9-10	6.6		1.09		8.4		64.8		18.3		8.6	
A14	-17.6	2-4	4.4		0.739		34.5		43.9		14.8		6.8	
		4-5	3.6		0.258		0.1		54.3		39.6		6	
A18	-2	7-9	3.4	U	0.699	U	49.7		42.2		5.8		2.3	
		9-10	3.5	U	0.042	U	44.9		53.2		2	U	2	U
		11-13	3.5	U	---		---		---		---		---	
B14	-3	0-2	4.7		0.224		51		43.7		3		2.4	
		2-3	4.8		---		---		---		---		---	
		8-10	3.7	U	0.116		36		63.4		0.7	U	0.7	U
B15	-2.2	9-10	18		0.658		51.6		41.2		3.9		3.3	
		11.5-13.5	3.5	U	0.069		60.7		37.9		1.4	U	1.4	U
		13.5-15.5	3.6	U	---		---		---		---		---	
C1 and C2 composite	17	0-4	3.4	U	0.285		18.8		64.4		14.2		2.6	
		4-8	3	U	0.136		1.6		89.9		7.9		0.4	
		8-12	3.2	U	0.12		1.6		93.3		4.2		1	
		12-16	---		---		---		---		---		---	
		16-20	---		---		---		---		---		---	
C3	17	0-2	3.3	UJ	1.94		33.4		57.2		7.4		2.1	
		2-4	3.4	UJ	---		---		---		---		---	
		4-6	3.5	UJ	0.674		6.4		85.2		6.7		1.7	
C4	17	0-2	2.2	JQ	6.25		80.3		16.3		2.3		0.9	
		2-4	3.4	U	---		---		---		---		---	
		4-6	3.4	U	0.239		2.4		77.6		16.1		3.9	
C5	17	0-2	3.3	UJ	6.27		87.1		10.5		2.4	U	2.4	U
		2-4	3.4	U	---		---		---		---		---	
		4-6	3.4	U	1.23		38.9		51.9		6.6		2.6	

--- not analyzed

- Notes:
1. Based on Anchor QEA data.
 2. Provided by Hart Crowser, Inc.
 - In-water core and boring sampling locations included sample collection to an elevation of -55 feet MLLW to characterize the dredge prism with a 2-foot over-dredge allowance and the post-dredge Z-layer.
 - Proposed locations may not be visible because they closely match the actual sampling locations and the proposed symbols are underneath the actual location symbols.
 - Existing and proposed Pier 4 locations provided by KPFF.
 - Bathymetric contour data provided by Port of Tacoma.
 - Background aerial imagery provided by Esri, 2011.

Abbreviations:
 DMMU = Dredged Material Management Unit
 MLLW = Mean lower low water
 OHWM = Ordinary High Water Mark

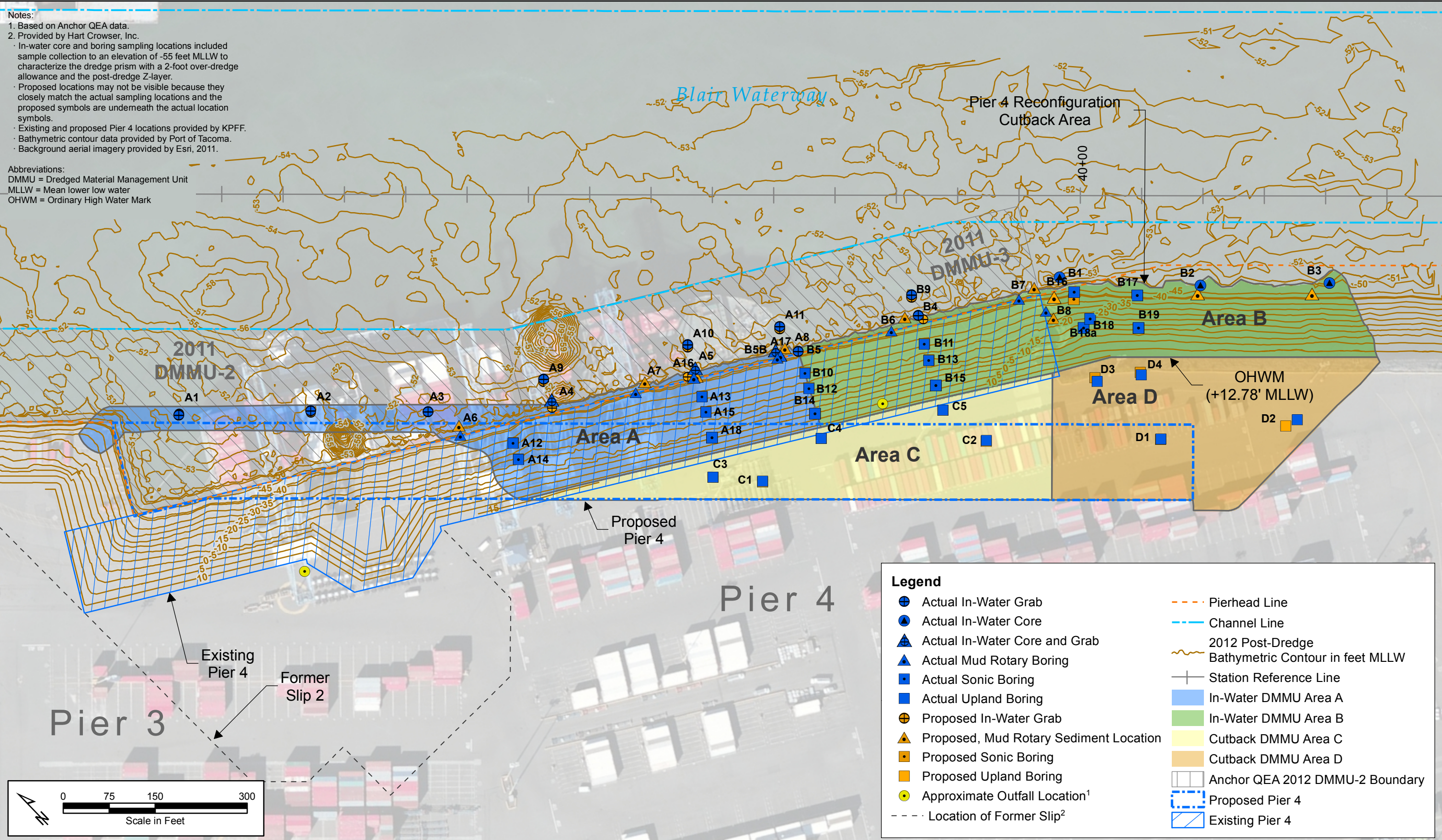

Legend

⊕	Actual In-Water Grab	- - -	Pierhead Line
⊙	Actual In-Water Core	—	Channel Line
⊕	Actual In-Water Core and Grab	—	2012 Post-Dredge Bathymetric Contour in feet MLLW
⊕	Actual Mud Rotary Boring	+	Station Reference Line
⊕	Actual Sonic Boring	■	In-Water DMMU Area A
⊕	Actual Upland Boring	■	In-Water DMMU Area B
⊕	Proposed In-Water Grab	■	Cutback DMMU Area C
⊕	Proposed, Mud Rotary Sediment Location	■	Cutback DMMU Area D
⊕	Proposed Sonic Boring	□	Anchor QEA 2012 DMMU-2 Boundary
⊕	Proposed Upland Boring	□	Proposed Pier 4
⊕	Approximate Outfall Location ¹	□	Existing Pier 4
⊕	Location of Former Slip ²		

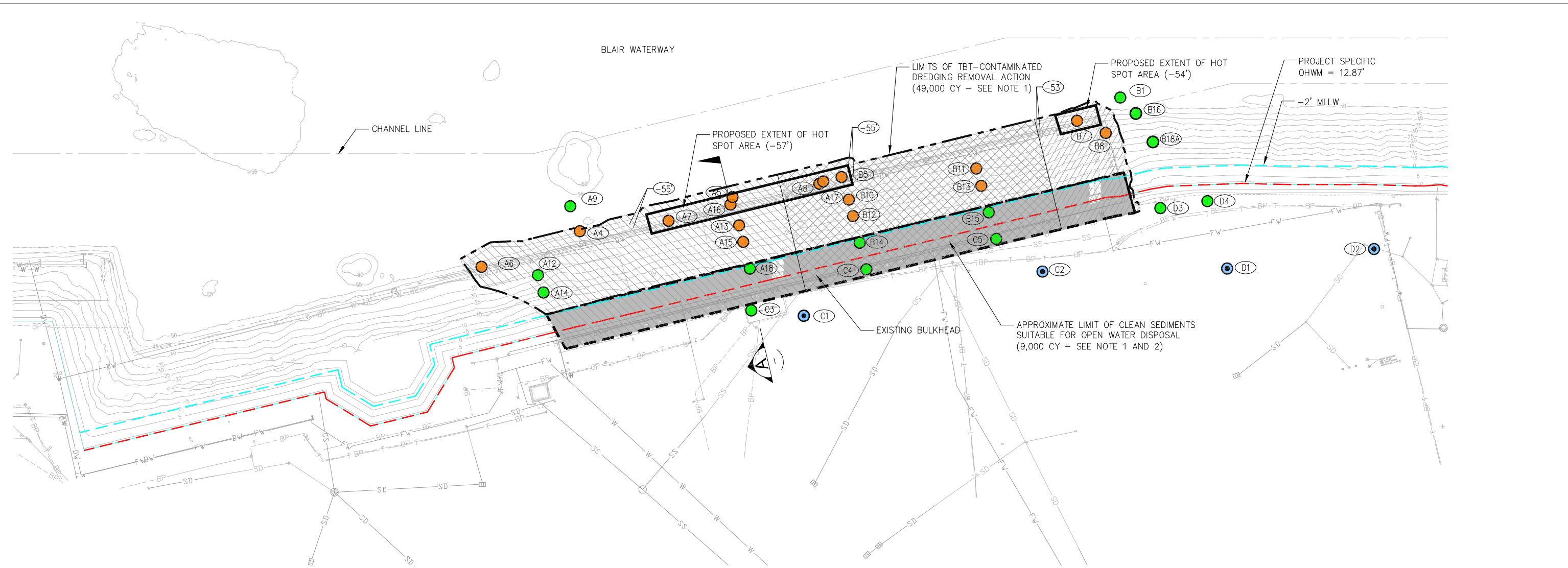

PHASE 1 DREDGE PLAN
SCALE: 1"=150'

LEGEND

- EXISTING CONTOUR
- TOE OF DREDGE, SEE NOTE 3
- SAMPLE LOCATION
- DREDGE SEDIMENT ALONG DEMOLISHED PIER FACE TO -55' MLLW AND UPPER 9FT OF SLOPE, SEE NOTE 3
- DREDGE SEDIMENT ALONG DEMOLISHED PIER FACE TO -55' MLLW AND UPPER 11FT OF SLOPE, SEE NOTE 3
- DREDGE SEDIMENT ALONG DEMOLISHED PIER FACE TO -53' MLLW AND UPPER 8FT OF SLOPE, SEE NOTE 3
- CROSS SECTION LOCATION
- SAMPLE LOCATIONS WITH SEDIMENT SAMPLES CONTAINING TBT CONCENTRATIONS GREATER THAN THE DMMP SCREENING LEVEL OF 73 UG/KG
- SAMPLE LOCATIONS WHERE THERE ARE NO TBT EXCEEDANCES OF THE DMMP TBT SCREENING LEVEL (73 UG/KG) (SAMPLES ANALYZED FOR TBT ONLY)
- SAMPLE LOCATIONS WHERE THERE ARE NO CHEMICAL EXCEEDANCES OF THE DMMP SCREENING LEVELS FOR THE DMMP SUITE OF CHEMICALS OF CONCERN

NOTES

1. VOLUME IS APPROXIMATE AND INCLUDES THE 1-FOOT OVERDREDGE ALLOWANCE.
2. THE 2-FOOT RIP RAP ARMORED SLOPE MATERIAL (APPROXIMATELY 2,3000 CY) HAS BEEN DEDUCTED FROM THE VOLUME.
3. DREDGE DEPTHS DO NOT INCLUDE THE 1-FOOT OVERDREDGE ALLOWANCE.

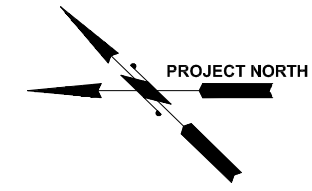

kpff Consulting Engineers

101 Stewart Street, Suite 400
Seattle, Washington 98101
(206) 382-0600 Fax (206) 382-0500

PROPOSED SUITABILITY OF PHASE 1 PROJECT
CLEAN MATERIAL
TACOMA, WASHINGTON
Figure 2 PHASE 1 DREDGE PLAN

DATE: DECEMBER 2014 SCALE: 1" = 150'-0"

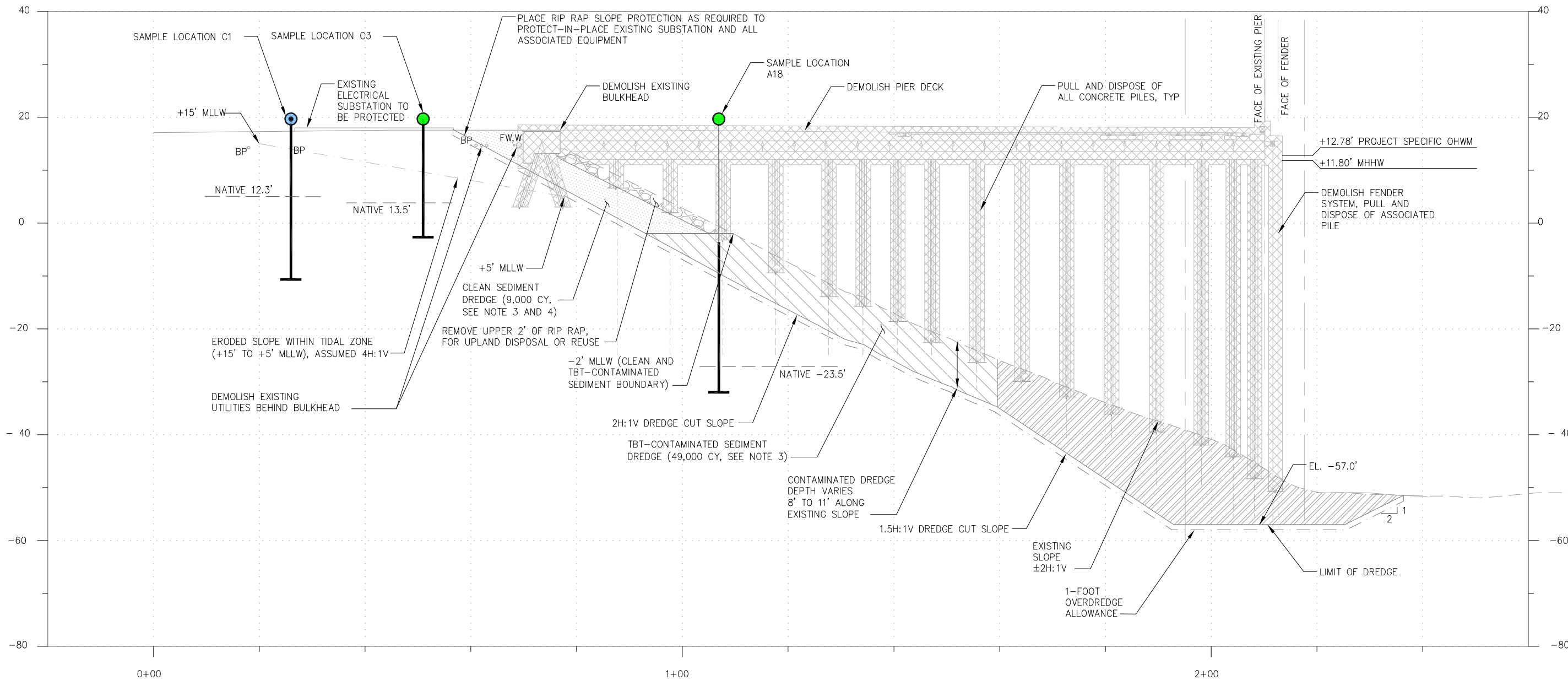

DREDGE SECTION A
SCALE: 1"=10'

LEGEND:

- EXISTING PIER TO BE DEMOLISHED DURING PHASE 1
- APPROXIMATE LOCATION OF CONTAMINATED SEDIMENT TO BE DREDGED (49,000 CY)
- APPROXIMATE LOCATION OF CLEAN SEDIMENT TO BE DREDGED (9,000 CY)
- LOCAL HOT SPOT (INCLUDED IN 49,000 CY)
- BP BURIED POWER CONDUIT
- FW FIRE WATER LINE
- W WATER LINE

- SAMPLE LOCATIONS WHERE THERE ARE NO TBT EXCEEDANCES OF THE DMMP TBT SCREENING LEVEL (73 UG/KG) (SAMPLES ANALYZED FOR TBT ONLY)
- SAMPLE LOCATIONS WHERE THERE ARE NO CHEMICAL EXCEEDANCES OF THE DMMP SCREENING LEVELS FOR THE DMMP SUITE OF CHEMICALS OF CONCERN

NOTES:

1. THE BOUNDARY BETWEEN THE CLEAN, NON-TBT CONTAMINATED SEDIMENTS AND THE TBT-CONTAMINATED SEDIMENTS AT -2 FT MLLW IS BASED ON THE LOCATION OF UNDER-PIER SEDIMENT CORES WHERE THE RESULTS OF THE TBT CHEMICAL ANALYSIS OF COLLECTED SAMPLES SHOWED THAT TBT WAS NOT DETECTED OR DETECTED AT CONCENTRATIONS BELOW THE DMMP TBT SCREENING LEVEL OF 73 UG/KG.
2. ONLY SAMPLE LOCATIONS BOUNDING THE CONTAMINATED SEDIMENT FROM THE CLEAN SEDIMENT ARE SHOWN.
3. VOLUME IS APPROXIMATE AND INCLUDES THE 1-FOOT OVERDREDGE ALLOWANCE.
4. THE 2-FOOT RIP RAP ARMORED SLOPE MATERIAL (APPROXIMATELY 2,300 CY) HAS BEEN DEDUCTED FROM THE VOLUME.



101 Stewart Street, Suite 400
Seattle, Washington 98101
(206) 382-0600 Fax (206) 382-0500

**PROPOSED SUITABILITY OF PHASE 1 PROJECT
CLEAN MATERIAL
TACOMA, WASHINGTON**
Figure 3 DREDGE SECTION A

DATE: DECEMBER 2014 SCALE: 1" = 10'-0"

- Notes:
- Based on Anchor QEA data.
 - Provided by Hart Crowser, Inc.
 - Result shown is TBT in porewater and is less than DMMP porewater screening level of 0.15 µg/L. Results from April 2013 Geoprobe sampling did not exceed the DMMP TBT screening level and are not shown on this figure.
 - Existing and proposed Pier 4 locations provided by KPFF.
 - Bathymetric contour data provided by Port of Tacoma.
 - Background aerial imagery provided by Esri, 2011.

Abbreviations:
 bml = Below mudline
 DMMP = Dredged Material Management Program
 DMMU = Dredged Material Management Unit
 ft = Feet
 MLLW = Mean lower low water
 µg/kg = Micrograms per kilograms
 µg/L = Micrograms per liter
 OHWM = Ordinary high water mark
 TBT = Tributyltin

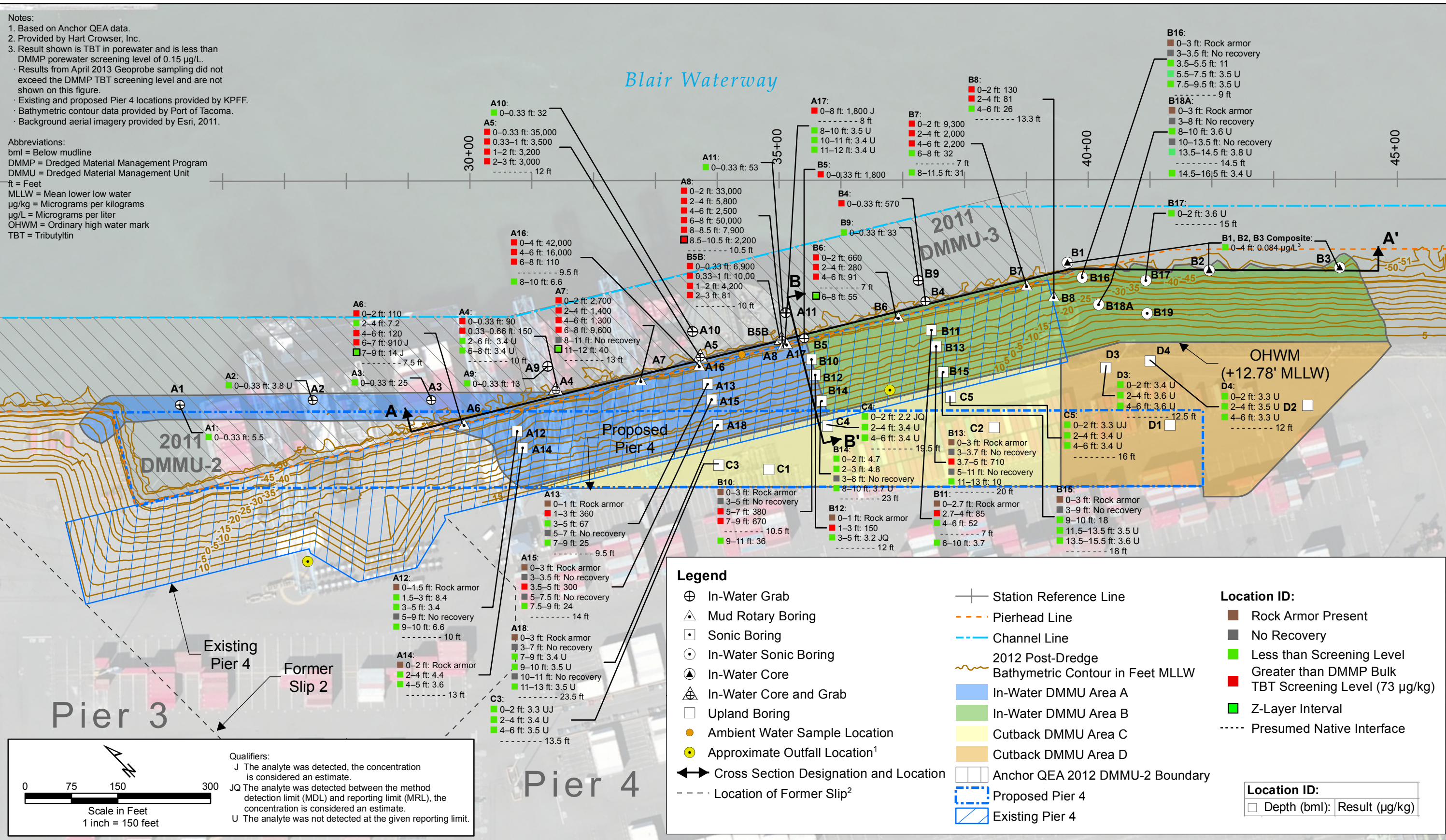

**Sediment Characterization Report
 Pier 4 Phase 2 Reconfiguration Project
 Tacoma, Washington**

**Figure 4.1
 Pier 4 Sediment and Soil Sample TBT Results**

Appendix A

Memorandum

To: Kelsey van der Elst, Dredged Material Management Office (DMMO)
Copies: Scott Hooton, Port of Tacoma
From: Jessi Massingale, Floyd|Snider
Date: December 22, 2014
Project No: POT-Pier 4
Re: Proposed Suitability of the Pier 4 Phase 1 Removal Action Project Clean Material

INTRODUCTION

The purpose of this memorandum is to describe the portion of material located within the Port of Tacoma (Port) Pier 4 Phase 1 Removal Action Project (Phase 1 Removal Action) dredge prism that is clean and not contaminated with tributyltin (TBT), and request that this material be determined suitable for open-water disposal at the Commencement Bay open-water disposal site by the Dredged Material Management Program (DMMP). The three objectives of this memorandum are to (1) provide a brief summary of the project phases, (2) present the delineation and characterization of the clean non-TBT-contaminated sediments, (3) describe the construction sequence for the removal of the clean sediments, as well as the extraction of concrete piling located within the clean material footprint and the concrete piling located downslope within the TBT-contaminated material, and (4) present the results of a conservative (assumed worst-case) piling removal contaminated sediment suspension calculation.

BACKGROUND

As part of the conceptual design and permitting process for the reconfiguration of Pier 4 (Terminal 4) to be in alignment with Pier 3 within the Husky Container Terminal, Floyd|Snider, on behalf of the Port, conducted three soil and sediment sampling events in 2013 under the DMMP for the characterization of the project cutback material for open water disposal or beneficial habitat reuse. The results of the characterization events identified TBT-contaminated sediments underneath and at the face of Pier 4. In consultation with the U.S. Environmental Protection Agency (USEPA) and the DMMP representatives, based on the TBT concentrations detected at Pier 4, the Port entered into an Agreed Order on Consent (AOC) with USEPA in June 2014 for a site removal action evaluation, which included an additional soil, sediment, and ambient site water sampling event that was conducted in July 2014. Following the review of the

preliminary results of the July sampling event, USEPA determined that the cleanup of the TBT-contaminated sediments is to proceed as a Time Critical Removal Action.

The Port is proceeding with removal of approximately 49,000 cubic yards (CY) of TBT-contaminated sediments located under Pier 4 as part of a future AOC with USEPA, and then reconfiguring and reconstructing Pier 4 to be in alignment with Pier 3 within the Husky Container Terminal. Pier 4 is located on the west side of the northern portion of the Blair Waterway, which lies within the Port's Industrial Development District (Figure 1).

The work occurring at Pier 4 will have two distinct work phases: (1) the Phase 1 Removal Action, which includes a USEPA-ordered cleanup of contaminated sediment, and (2) the Phase 2 Reconfiguration Project (Phase 2 Project), which includes reconfiguration of the existing pier. The proposed project, including both phases, is planned to be completed over 3 years, with work tentatively scheduled to be conducted between 2015 and early 2018. The schedule and construction timing of Phase 2 is dependent upon the timing of the completion of the Phase 1 Removal Action, and will not start until the Phase 1 project is deemed complete by USEPA.

The Port is requesting that a portion of material located within the Phase 1 Removal Action dredge prism that is clean and not contaminated with TBT be determined suitable for open-water disposal via a suitability determination. The removal of the approximately 9,000¹ CY of clean sediments located at the top of the slope will occur prior to the removal of the approximately 49,000 CY of TBT-contaminated sediments and then post-dredge confirmational sampling (to be approved by both USEPA and the DMMP) will be conducted to confirm that the removal action achieved the project objectives and completion requirements. Post-dredge confirmational sampling will also be used to confirm the suitability of the underlying 500,000 CY of cutback material to be dredged under Phase 2 for open water disposal or beneficial use. As part of the Phase 2 Project, the Port will continue to work with the DMMP to secure a suitability determination for the Phase 2 cutback material for open-water disposal or beneficial use. Therefore, the Port is seeking to secure two separate suitability determinations, the first (described in this memorandum) for the Phase 1 Removal Action top of slope clean 9,000 CY and the second for the Phase 2 Project 500,000 CY of cutback material. The characterization of the Phase 2 cutback material, as well as sampling results to support the delineation of the top of slope clean 9,000 CY, is summarized in the Sediment Characterization Report (Floyd|Snider 2014a).

TOP OF SLOPE MATERIAL PROPOSED SUITABILITY

As part of the Phase 1 Removal Action, prior to removal of the TBT-contaminated sediments under the pier and at the pier face, the majority of the existing pier structure will be demolished (Figure 2). In order to facilitate the dredging of the approximately 9,000 CY of clean sediments, prior to dredging, the 2-foot layer of riprap armor (approximately 2,300 CY) will be removed and

¹ The approximately 9,000 CY of clean sediments does not include the upper 2 feet of riprap armoring that will be removed separately from the clean material. The volume does include an assumed 1-foot over-dredge allowance.

disposed of upland at an appropriate facility or reused by the Port. In order to access the approximately 49,000 CY of TBT-contaminated sediments located under the mid- to lower-slope of the pier and the pier face, approximately 9,000 CY of clean material will be removed from the existing bulkhead, down to an elevation of -2 feet mean lower low water (MLLW). This cut of clean material will be the full length of the existing pier, approximately 1,000 feet long, extending downslope approximately 30 feet, and to a variable depth of 8 to 11 feet. If this clean material were left in place when the contaminated material downslope is dredged it would create an unstable slope, which would likely collapse; therefore, this clean material must be removed prior to the dredging of the downslope TBT-contaminated sediment. It is this top of slope 9,000 CY that the Port is requesting be considered for suitability for disposal at the Commencement Bay open-water disposal site.

Soil and Sediment Characterization Results

The characterization sampling results to support the delineation of the top of slope clean 9,000 CY is summarized in the Sediment Characterization Report (Floyd|Snider 2014a). Table 1 provides a summary of the TBT sediment and soil analytical results. Additionally, Figure 3 shows the dredge plan of the top of slope 9,000 CY of clean, non-TBT-contaminated sediments, and the downslope TBT-contaminated sediments. Figure 4 shows a cross section of the boundary of clean and TBT-contaminated sediments upslope of the proposed hot spot, in line with Locations A16 and A5.

In general, field characterization events have not encountered any unique fill or debris material and no visual indications of contamination (e.g., paint chips, sheen, odor, etc.) have been observed in any upland or sediment location.

Soil sampling conducted in April 2013 found no exceedances of any of the DMMP screening levels (SLs) in any upland location, as shown by the blue symbols in Figures 3 and 4.

In July 2014, five upland borings (C3, C4, C5, D3, and D4) were advanced in order to define the boundary between the upland DMMUs and the in-water DMMUs. Sample Locations C3, C4, and C5 were positioned in-line with and shoreward of under-pier Sample Locations A18, B14, and B15 (described below). Based on previous sampling events, native material has been confirmed to be clean. Native material was encountered at depths ranging from 13.5 to 19 feet below ground surface (bgs). The top three samples collected from C3, C4, and C5 were analyzed for bulk TBT. TBT was detected at 2.2 micrograms per kilogram ($\mu\text{g}/\text{kg}$) in the surface sample collected from C4, and remaining sample results for all locations were non-detect at laboratory reporting limits ranging from 3.3 to 3.5 $\mu\text{g}/\text{kg}$. These sample locations are shown as green symbols on Figure 3.

In November 2013, rows of roto-sonic borings were advanced through holes in the pier deck at approximately -33 feet MLLW and -29 feet MLLW. These borings encountered riprap rock armor, which prevented recovery in most of the surface intervals. TBT contamination greater than the DMMP SL was encountered in the central and southern portions of the under-pier slope. At the

northern end of the pier, detected TBT concentrations were less than the DMMP SL (Figure 3). Sample recovery was generally good immediately below the riprap rock armor in this area. At Sample Location A12, TBT was detected at 8.4 µg/kg in the shallowest sample, 1.5 to 3 feet below mudline (bml), able to be collected from below the riprap rock armor and at 3.4 µg/kg in the underlying 3 to 5 feet bml sample. At Sample Location A14, TBT was detected at 4.4 µg/kg in the shallowest, 2 to 4 feet bml sample able to be collected and 3.6 µg/kg in the underlying 4 to 6 feet bml sample. Native material was encountered at -40 feet MLLW at A12 and -30 feet MLLW at A14. These sample locations are shown as green symbols on Figure 3.

In the July 2014 event, an additional row of roto-sonic borings were advanced through holes in the pier deck at -2 feet MLLW to provide upslope delineation of the under-pier TBT contamination encountered during the November 2013 sampling event at Sample Locations A15, B12, and B13, as shown in Figure 3. During the July 2014 sampling event, the under-pier roto-sonic borings were advanced at their planned locations; however, the riprap also resulted in poor recovery at most locations during this event, primarily in the surface intervals. At Sample Locations A18 and B15, the presence of surface riprap prevented the “soupy” nature of the sediments located within and underlying the riprap from being recovered and sampled because the sediments were not dense enough to push the riprap up through the core barrel. However, the surface intervals were able to be recovered at Sample Location B14 because a large piece of riprap at 3 feet prevented further downward movement of the core barrel. The driller was able to pull up the core barrel with the top 3 feet of rock and intermixed sediment that was intact and the material was sampled. This differed from Sample Locations A18 and B15 in that the riprap completely plugged the core barrel, preventing any additional material from being captured and retained. B14 is the sampling location upslope and closest to the central hot spot, thereby providing confirmation that the upper intervals at this elevation are not impacted by the down slope TBT concentrations. The upper intervals of material at Sampling Locations A18 and B15 that were not able to be recovered are presumed to consist of approximately 2 feet of riprap, with the underlying non-recovered interval presumed to be a mix of small gravel and sediment, based on how the driller could physically feel the change in resistance between riprap and sediment.

Native material at Sample Locations A18, B14, and B15 was encountered at elevations between -20 feet and -26 feet MLLW. The top four samples that were able to be collected from Sample Locations A18, B14, and B15 were analyzed for bulk TBT. TBT was detected in the top (0 to 2 feet bml) and the 2 to 3 feet bml samples collected from B14 (4.7 µg/kg and 4.8 µg/kg, respectively). At B15, TBT was detected at 18 µg/kg in the uppermost (9 to 10 feet bml) sample able to be collected. All TBT detections were significantly less than the DMMP TBT SL of 73 µg/kg. TBT was not detected in the samples collected from A18, or deeper samples collected from B14 and B15, at laboratory reporting limits ranging from 3.4 to 3.7 µg/kg. These sample locations are shown as green symbols on Figure 3.

Therefore, TBT contamination has been determined to not be present in sediments at elevation -2 feet MLLW as supported by sample results from A18, B14, and B15 located at this elevation and from A12 and A14 located downslope of -2 feet MLLW at the northern end of the pier. No

assumptions were made about the clean material extending downslope and this elevation forms the basis for the downslope/waterward boundary between clean, non-TBT-contaminated sediment and TBT-contaminated material. The results from the upland locations described above confirm the upper, shoreward boundary of the clean, non-TBT-contaminated sediment.

Phase 1 Removal Action Construction Sequence

The majority of the existing pier structure will be demolished prior to the removal of any underlying sediment (Figure 2). This demolition includes the removal of approximately 140,550 square feet of pier structure and vibratory extraction of approximately 1,047 concrete piles, 87 creosote-treated timber piles, and 22 steel piles associated with the existing pier.

The Phase 1 Removal Action construction sequence for demolition, pile extraction, and dredging includes the following:

- Demolition of the existing fender system (located at the pier face), utilities, and other appurtenances, and existing crane beam, bull rail, and all crane appurtenances.
- Demolition of the pier deck, deck beams, and pile caps. The bulkhead will also be demolished and removed, along with the pier structure, as the pier deck demolition progresses.
- Vibratory extraction of the pier face fender system timber and steel piling and the slope concrete piling.
- Removal of the 2-foot layer of riprap armor on top of the 9,000 CY of clean, non-TBT contaminated sediment (approximately 2,300 CY).
- Removal of the top of slope 9,000 CY of clean, non-TBT-contaminated sediments.
- Removal of the mid-slope to toe of slope 49,000 CY of TBT-contaminated sediments.
- Surveying and post-dredge confirmational sediment sampling to confirm the removal of the TBT-contaminated sediments.

Figure 3 shows the dredge plan of the top of slope 9,000 CY of clean, non-TBT-contaminated sediments, and the downslope TBT-contaminated sediments. Also shown on Figure 3 are the material characterization sample locations, as described above. Removal of the clean top of slope material will be conducted either from the uplands with the use of a crawler crane or from a mechanical bucket dredge on a floating derrick barge. The thickness of the dredge cut along the slope through the entire Phase 1 dredge prism varies based on the depth of detected TBT concentrations greater than the DMMP SL. The slope dredge cut thicknesses of 9 feet, 11 feet, and 8 feet, as indicated on Figures 3 and 4, apply to both the top of slope clean material and the downslope TBT-contaminated material.

Figure 4 also shows the location of the pier face fender system, which includes creosote-treated timber and steel piles, as well as the under-pier 16.5-inch-diameter concrete piles. The piles

located within the clean, top of slope material and the downslope TBT-contaminated material, are concrete piles until the pier face.

SLOPE CONCRETE PILE EXTRACTION AND CONTAMINATED SEDIMENT SUSPENSION

During initial discussion of the potential suitability of the top of slope clean material for open-water disposal with the DMMP, a question arose regarding the possibility that during vibratory pile extraction of the concrete piles located downslope of the clean top of slope material, TBT-contaminated sediment could be suspended and deposited on the top of slope material. The question as discussed on the August 28, 2014 conference call was:

Could TBT-contaminated sediment particles that were attached to the concrete slope piling be suspended in the water column and transported upslope to be deposited on the clean top of slope material proposed for open water disposal at a concentration of concern?

The following sections are presented to address this question by providing concrete piling extraction methodology information, relevant site condition information, and a conservative, assumed worst-case calculation that determines the thickness of TBT-contaminated sediment that could be suspended during pile extraction and deposited as a thin veneer over the top of slope clean material footprint, as well as what concentration of TBT would have to be present within that deposited sediment to result in the top 1 foot of the dredge prism sediment exceeding the DMMP TBT SL of 73 µg/kg.

Concrete Piling Extraction Methodology

The methodology that will be used to extract large structural concrete piles will be to vibrate them out using a “vibro-hammer” or “vibratory driver/extractor.” Such a device consists of three main components: (1) the clamp that attaches the device to the top of the pile, (2) the vibrating mechanism consisting of weights that are spun generating an oscillating force in the up or down direction (up direction for extraction), and (3) the suspension system that isolates the crane from the vibrating mechanism for safety of the crane. The vibro-hammer is provided power by a diesel engine driving a hydraulic pump. Although typically there is little-to-no sound or visible operation of the vibro-hammer during piling extraction, a substantial amount of energy is transferred directly into the pile, making the pile vibrate up and down approximately ¾ of an inch at a time.

The effect of this transfer of energy to the pile and significant weight included in both the vibrating parts of the hammer and the pile itself (e.g., on the order of tens of thousands of pounds) is to shear the sediment away from the sides of the pile and “liquefy” the sediment in the immediate surrounding area. This results in minimal sediment remaining attached to the piling, particularly the concrete piles. The suspension system and crane can then pull up the pile and extract it from the sediment.

The vibratory methodology results in a breaking of the suction between the pile and the surrounding sediments the pile is embedded in, and, as described above, shears sediment from the sides of the pile, limiting the amount of sediment adhering to the pile sides. The primary sediment composition at Pier 4, which consists of silty sands and riprap underlain by more sandy sediments with some silt and gravel lenses, further reduces the potential for sediment remaining attached to the piles. Additionally, the piling at Pier 4 will be pulled up through riprap rock, which acts to scrape sediment residue off the pile before that portion of the pile encounters the water column, further reducing suspension of any attached sediment.

Photograph 1 below shows the limited amount of clay attached to a recently extracted concrete pile from Gulf Port, Mississippi. As sand will tend not to adhere to the pile, much less sediment would be expected to adhere to the concrete piling at Pier 4 relative to a sediment composed primarily of clay. Photograph 2 shows an extracted concrete pile from Port of Long Beach sediments with a lower clay content, and relatively little attached sediment on the right end of the pile and marine growth on the left, upper end of the pile.



Photograph 1. Port of Gulfport Restoration Program -
West Pier Wharf Upgrade (September 2013)



Photograph 2. Port of Long Beach Pier T Demolition

Pier 4 Under-Pier Diver Sediment Survey Findings

The Pier 4 wharf overlies a 2:1 riprap armored slope with variable thicknesses of accumulated sediment on top of the riprap. In July 2014 an underwater inspection of the concrete piles and a survey of the depth of sediment cover over riprap was conducted within the area of the structure to be demolished, or the majority of the pier (Echelon 2014). The July 2014 diver survey was conducted by probing the sediments along individual and representative bents (rows of concrete piles extending from top of slope to the pier face toe of slope) at approximate 10-bent intervals. The data were obtained by inserting a calibrated 6-foot-long, 1/8-inch-diameter steel probe into the sediment and pushing it down until refusal. The sediment thickness was recorded to the nearest ¼ foot.

No sediment cover was found throughout the upper/shoreward 30 percent of the concrete pile bents, or approximate shoreward 40 feet of the pier structure. This upper 30 percent extends outward to an elevation below -2 feet MLLW. Therefore, even under existing conditions of tidal fluctuation and vessel berthing with associated water movement, sediment has not been deposited within this top of slope area. Down slope of the 9,000 CY clean non-TBT-contaminated sediment dredge prism, for the remaining approximately 90 feet of the pier, the sediment depth was found to range from less than ¼ foot near the interface of the riprap and sediment, to approximately 4 to 6 feet at the pier face (Echelon 2014).

Conservative (Worst-Case) Pile Extraction and Suspended Sediment Calculation

As described above, the July 2014 diver survey documented that no sediment cover was found throughout the upper/shoreward 30 percent of the concrete pile bents, which includes the 9,000 CY clean non-TBT-contaminated sediment dredge prism. This is consistent with the expectation that the probable location and direction of deposition of suspended sediment would be on the lower portions of the slope and outward to the toe of slope and not upslope. However, to address the DMMP suspended sediment question, a calculation was performed to determine the assumed worst-case thickness of TBT-contaminated sediment that could be suspended during pile extraction and deposited as a thin veneer over the top of slope clean material footprint, as well as what concentration of TBT would have to be present within that deposited sediment to result in the top 1 foot of the clean dredge prism sediment exceeding the DMMP TBT SL of 73 µg/kg. The site information and assumptions used in the calculation are presented in Table 2 and in summary include the following:

- Concrete pile size of slope piles to be removed: 16.5 inches in diameter.
- Average thickness of TBT-contaminated sediment located on the lower slope: 10 feet.
- Conservative assumed worst case assumed thickness of sediment attached to 10 feet of the piling surface: 0.25 inches.
- Approximate number of concrete piles located within TBT-contaminated sediment: 691 piles or approximately two thirds of the 1,047 total concrete piles to be removed.
- 100 percent of the TBT-contaminated sediment attached to the concrete piles is suspended in the water column (not removed from the pile as it is extracted through the slope armoring, nor remaining attached to the pile as it is pulled up and out of the water column).
- 100 percent of the TBT-contaminated sediment suspended in the water column from the pile is carried up slope and deposited within the footprint of the top of slope clean material dredge prism.
 - The TBT-contaminated sediment that is deposited upslope is spread uniformly over the clean material dredge prism surface.

Under the assumptions and site pile information identified above, the results of the conservative calculation include the following:

- The maximum volume of TBT-contaminated sediment that could be suspended and deposited over the clean material dredge prism surface is approximately 24 CY.
 - This is 24 CY spread over 43,300 square feet and a total clean material dredge prism volume of 9,000 CY (approximately 0.2 percent of the dredge prism volume).

- The maximum thickness of TBT-contaminated sediment that could be deposited over the clean material dredge prism surface as a thin veneer is approximately 0.18 inches.
 - Existing conditions with tidal fluctuations and vessel berthing and water movement, as determined in the July 2014 survey, have resulted in no sediment cover over the top of slope area.
- The TBT-concentration of the sediment resulting from extracting piles from the contaminated downslope area and subsequent deposition over the clean material dredge prism that would result in a TBT concentration in the top 1 foot of the clean material dredge prism exceeding the DMMP SL (73 µg/kg) is 4,540 µg/kg. The TBT-concentration of the top 1 foot for the dredge prism is calculated using the following equation, where the concentration in the top 1 foot is 73 µg/kg, the contaminated depth is 0.18 inches (0.015 feet), the clean depth is 0.985 feet, and the assumed clean concentration is 5 µg/kg.

$$TBT\text{-conc. of sed} = \frac{\text{top 1 foot conc.} \times 1 \text{ foot} - \text{clean depth} \times \text{clean conc.}}{\text{contaminated depth}}$$

- The average TBT sediment concentration of samples collected from the under-pier area (excluding the pier face samples) is 127 µg/kg, which is substantially less than the 4,540 µg/kg determined necessary to result in the top 1 foot of the clean material dredge prism exceeding the DMMP TBT SL.
- The average TBT sediment concentration of all samples collected from within the dredge prism (including the pier face samples and hot spot areas located approximately 90 feet from the waterward edge of the clean material dredge prism) is 3,250 µg/kg; less than the 4,540 µg/kg determined necessary to result in the top 1 foot of the clean material dredge prism exceeding the DMMP TBT SL.
- The thickness of TBT-contaminated sediment that would have to be suspended and deposited over the clean material dredge prism, if the average TBT sediment concentration of samples collected from the under-pier area (127 µg/kg)² was assumed, is approximately 6.7 inches.
 - Based on the calculation assumptions and pile information (the pile diameter size, the thickness of slope contaminated sediment, assumed sediment thickness attached to piles, and 100 percent sediment transport and deposition, etc.) the maximum thickness of TBT-contaminated sediment that could be deposited over the clean material dredge prism surface as a thin veneer is approximately 0.18 inches, which is less than 3 percent of the thickness necessary to result in the

² The TBT chemical results collected from the sampling borings located under the pier and within the dredge prism were used to calculate the average concentration of 127 µg/kg. Samples collected from locations A13, A15, A18, B10, B11, B12, B13, B14, and B15.

surface exceedance (6.7 inches) using the average TBT sediment concentration of samples collected from the under-pier area.

CLEAN DREDGING ADDITIONAL BEST MANAGEMENT PRACTICES

In addition to the dredge best management practices (BMPs) that are described in the *Final Pier 4 Phase 1 Removal Action Project - Phase 1 Project Description Document* (Floyd|Snider 2014b) to be implemented during the Phase 1 Removal Action, during the dredging of the top of slope clean 9,000 CY, prior to the dredging of TBT-contaminated sediments, the following BMPs will be implemented:

- Following removal of the overlying pier structure and riprap and during the beginning of dredging, a visual inspection of the clean material to be dredged will be conducted by verifying depth and visually monitoring the dredge material on the barge to ensure there is no debris present at the surface of the dredge prism.
- If the dredging is conducted at dusk or at night, the Contractor shall ensure that sufficient light is provided for visual monitoring of the dredge prism for turbidity and to visually inspect for debris or large rocks within the disposal barge.

CONCLUSION

Based on the results of the sediment characterization sampling that has been conducted under both the DMMO and USEPA programs, the results of the July 2014 diver survey, and the physical location and site conditions of the top of slope 9,000 CY, the Port proposes the top of slope 9,000 CY material is suitable for disposal at the Commencement Bay open-water disposal site. The proposed suitability of the top of slope clean 9,000 CY is specifically based on the following characterization results and physical conditions:

- TBT contamination has been determined to not be present in sediments at elevation -2 feet MLLW. No assumptions were made about the clean material extending downslope and this elevation forms the basis for the downslope/waterward boundary between clean, non-TBT-contaminated sediment and TBT-contaminated material.
 - As described above, multiple feet at the surface of Sample Locations A18 and B15 was not recovered due to the presence of rock armor on the slope. However, the surface 3 feet of rock and intermixed sediment was recovered and analyzed for TBT at Sample Location B14. The resulting TBT concentrations were less than 5 µg/kg, just greater than the analytical reporting limit. Sample Location B14 is located upslope and closest to the pier face Sample Location A8 with the maximum TBT concentration of 50,000 µg/kg (Table 1). Therefore, the results of the analysis of samples collected from this location support the conclusion that the extent of TBT contamination does not extend to the -2 feet MLLW sampling elevation.

- During the July 2014 diver survey, no sediment cover was found throughout the upper slope including the footprint of the 9,000 CY clean, non-TBT-contaminated sediment dredge prism. Therefore, even under existing conditions of tidal fluctuation and vessel berthing with associated water movement, sediment has not been deposited within this top of slope area. The results of the sampling events conducted to date indicate that the TBT-contaminated sediment located downslope of the 9,000 CY clean non-TBT-contaminated sediment dredge prism is associated with sediment located directly over and under riprap armoring. The lack of sediment cover on the clean dredge prism further supports that this area has not been impacted by the downslope TBT contamination.
- The 9,000 CY clean sediment dredge prism is located from top of slope at approximate elevation of 18 feet MLLW down to elevation -2 feet MLLW. During the majority of the tidal cycle, this upper portion of the slope is not inundated with water and is in the dry, above the water level of the waterway. This also reduces the potential for suspension and deposition of downslope sediment on top of the proposed clean sediment dredge prism.

Additionally, the concrete piling vibratory extraction methodology, relevant site conditions, and results of the conservative contaminated sediment and pile extraction calculation provide multiple lines of evidence that even under assumed worst-case calculation scenarios, the suspension of contaminated sediment during pile extraction prior to the removal of the clean material dredge prism will not result in recontamination of the clean top of slope 9,000 CY of material.

REFERENCES

Echelon Engineering, Inc. (Echelon). 2014. Pier 4 Relocation Pile *Inspection*. Prepared for KPFF Consulting Engineers. July.

Floyd|Snider. 2014a. *Sediment Characterization Report, Pier 4 Reconfiguration Project, Blair Waterway, Tacoma, Washington*. Prepared for Port of Tacoma. 24 November.

Floyd|Snider. 2014b. *Final Pier 4 Phase 1 Removal Action Project Phase 1 Project Description Document*. Prepared for Port of Tacoma. 12 September.

TABLES

Table 1	Summary of Tributyltin Analytical Results in Sediment and Soil Samples
Table 2	Potential Sediment Suspension and Tributyltin Concentrations Results from Concrete Pile Extraction

FIGURES

- Figure 1 Site Location Map of Pier 4
- Figure 2 Phase 1 Site Plan
- Figure 3 Phase 1 Dredge Plan
- Figure 4 Dredge Section A

Tables

Table 1
Summary of Tributyltin Analytical Results in Sediment and Soil Samples

DMMU Sampling Location		Pier Face—Power Grab and Mud Mole Core Samples																	
		A4				A5				B4	B5	B5-B							
Sample ID		A4-01	A4-01A	A4-02	A4-03A	A4-04A	A5-01	A5-01A	A5-02A	A5-03A	A5-04A	B4-01	B5-01A	B5-01B	B5-02B	B5-03B	B5-04B		
Sample Date		1/0/1900	8/8/2013	4/19/2013	8/8/2013	8/8/2013	4/19/2013	8/8/2013	8/8/2013	8/8/2013	8/8/2013	8/9/2013	8/9/2013	8/9/2013	8/9/2013	8/9/2013	8/9/2013		
Depth (bml)		0-10 cm	0-10 cm	10-20 cm	2-6 ft	6-8 ft	0-10 cm	0-10 cm	10 cm-1 ft	1-2 ft	2-3 ft	0-10 cm	0-10 cm	0-10 cm	10 cm-1 ft	1-2 ft	2-3 ft		
Chemical	Unit	DMMP Criteria																	
		SL	BT																
Tributyltin (Bulk)	µg/kg	73	73	90	17 J	150	3.4 U	3.4 U	7,000	35,000	3,500	3,200	3,000	570	1,800	6,900	10,000	4,200	81
Tributyltin (Interstitial Water)	µg/L	0.15	0.15	NA	0.037	NA	0.018 JQ	NA	NA	3.8	5.1	0.73 UJ	0.2	0.12	1	1.5 UJ	NA	NA	NA

DMMU Sampling Location		Pier Face—Mud Rotary Boring Samples																	
		A6					A7					A8							
Sample ID		A6-01	A6-02	A6-03	A6-04	A6-05	A7-01	A7-02	A7-03	A7-04	A7-05	A8-01	A8-02	A8-03	A8-04	A8-05	A8-06		
Sample Date		11/15/2013	11/15/2013	11/15/2013	11/15/2013	11/15/2013	11/15/2013	11/15/2013	11/15/2013	11/15/2013	11/15/2013	11/16/2013	11/16/2013	11/16/2013	11/16/2013	11/16/2013	11/16/2013		
Depth (bml)		0-2 ft	2-4 ft	4-6 ft	6-7 ft	7-9 ft	0-2 ft	2-4 ft	4-6 ft	6-8 ft	11-12 ft	0-2 ft	2-4 ft	4-6 ft	6-8 ft	8-8.5 ft	8.5-10.5 ft		
Chemical	Unit	DMMP Criteria																	
		SL	BT																
Tributyltin (Bulk)	µg/kg	73	73	110	7.2	120	910 J	14 J	2,700	1,400	1,300	9,600	40	33,000	5,800	2,500	50,000	7,900	2,200

DMMU Sampling Location		A16				A17				B6				B7							
Sample ID		A16-01	A16-02	A16-03	A16-04	A17-01	X17-01 (dup)	A17-02	A17-03	A17-04	B6-01	B6-02	B6-03	B6-04	B7-01	B7-02	B7-03	B7-04	B7-05		
Sample Date		7/11/2014	7/11/2014	7/11/2014	7/11/2014	7/10/2014	7/10/2014	7/10/2014	7/10/2014	7/10/2014	11/16/2013	11/16/2013	11/16/2013	11/16/2013	11/14/2013	11/14/2013	11/14/2013	11/14/2013	11/14/2013		
Depth (bml)		0-4 ft	4-6 ft	6-8 ft	8-10 ft	0-8 ft	0-8 ft	8-10 ft	10-11 ft	11-12 ft	0-2 ft	2-4 ft	4-6 ft	6-8 ft	0-2 ft	2-4 ft	4-6 ft	6-8 ft	8-11.5 ft		
Chemical	Unit	DMMP Criteria																			
		SL	BT																		
Tributyltin (Bulk)	µg/kg	73	73	42,000	16,000	110	6.6	1,800 J	340 J	3.5 U	3.4 U	3.4 U	660	280	91	55	9,300	2,000	2,200	32	31

DMMU Sampling Location		S. Pier End—Mud Rotary Boring Samples (at Midslope)					
		B18A					
Sample ID		B18A-01 ¹	X18A-01 ¹ (dup)	B18A-02	B18A-03		
Sample Date		7/1/2014	7/1/2014	7/1/2014	7/1/2014		
Depth (bml)		8-10 ft	8-10 ft	13.5-14.5 ft	14.5-16.5 ft		
Chemical	Unit	DMMP Criteria					
		SL	BT				
Tributyltin (Bulk)	µg/kg	73	73	3.6 U	3.6 U	3.8 U	3.4 U

DMMU Sampling Location		S. Pier End—Mud Rotary Boring Samples (at approx. -28 ft MLLW)				
		B8				
Sample ID		B8-01	B8-02	B8-03		
Sample Date		11/13/2013	11/13/2013	11/13/2013		
Depth (bml)		0-2 ft	2-4 ft	4-6 ft		
Chemical	Unit	DMMP Criteria				
		SL	BT			
Tributyltin (Bulk)	µg/kg	73	73	130	81	26

DMMU Sampling Location		S. Pier End—Mud Rotary Boring Samples (at Midslope)					
		B16					
Sample ID		B16-01 ¹	B16-02	B16-03	B17-01		
Sample Date		7/1/2014	6/30/2014	6/30/2014	7/1/2014		
Depth (bml)		3.5-5.5 ft	5.5-7.5 ft	7.5-9.5 ft	0-2 ft		
Chemical	Unit	DMMP Criteria					
		SL	BT				
Tributyltin (Bulk)	µg/kg	73	73	11	3.5 U	3.5 U	3.6 UJ

DMMU Sampling Location		A1				
		A1	A2	A3		
Sample ID		A1-01	A2-01	A3-01		
Sample Date		4/19/2013	4/19/2013	4/19/2013		
Depth (bml)		0-10 cm	0-10 cm	0-10 cm		
Chemical	Unit	DMMP Criteria				
		SL	BT			
Tributyltin (Bulk)	µg/kg	73	73	5.5	3.8U	25
Tributyltin (Interstitial Water)	µg/L	0.15	0.15	NA	NA	NA

DMMU Sampling Location		Berth Outside of Dredge Prism—Power Grab Samples					
		A9					
Sample ID		A9-01	A10-01	A11-01	B9-01		
Sample Date		11/14/2013	11/14/2013	11/14/2013	11/14/2013		
Depth (bml)		0-10 cm	0-10 cm	0-10 cm	0-10 cm		
Chemical	Unit	Criteria					
		SL	BT				
Tributyltin	µg/kg	73	73	13	32	53	33
Tributyltin	µg/kg	73	73	13	32	53	33

DMMU Sampling Location		Under Pier—Roto-sonic Boring Samples (at approx. -33 ft MLLW)																
		A12			A13				B10				B11					
Sample ID		A12-01	A12-02	A12-03	A13-01	A13-02	R13-02 (dup)	A13-03	B10-01	B10-02	B10-03	R10-03 (dup)	B11-01	B11-02	B11-03	R11-03 (dup)		
Sample Date		11/15/2013	11/15/2013	11/15/2013	11/15/2013	11/15/2013	11/15/2013	11/15/2013	11/14/2013	11/14/2013	11/14/2013	11/14/2013	11/13/2013	11/13/2013	11/13/2013	11/13/2013		
Depth (bml)		1.5-3 ft	3-5 ft	9-10 ft	1-3 ft	3-5 ft	3-5 ft	7-9 ft	5-7 ft	7-9 ft	9-11 ft	9-11 ft	2.7-4 ft	4-6 ft	6-10 ft	6-10 ft		
Chemical	Unit	DMMP Criteria																
		SL	BT															
Tributyltin (Bulk)	µg/kg	73	73	8.4	3.4	6.6	360	45 J	67	25	380	670	36	13	85	52	3.4	3.7

Table 1
Summary of Tributyltin Analytical Results in Sediment and Soil Samples

Under Pier—Roto-sonic Boring Samples (at approx. -19 ft MLLW)											
DMMU Sampling Location		A14		A15		B12		B13			
Sample ID		A14-01	A14-02	A15-01	A15-02	B12-01	B12-02	B13-01	B13-02		
Sample Date		11/16/2013	11/16/2013	11/15/2013	11/15/2013	11/14/2013	11/14/2013	11/13/2013	11/13/2013		
Depth (bml)		2-4 ft	4-5 ft	3.5-5 ft	7.5-9 ft	1-3 ft	3-5 ft	3.7-5 ft	11-13 ft		
Chemical	Unit	DMMMP Criteria									
		SL	BT								
Tributyltin (Bulk)	µg/kg	73	73	4.4	3.6	300	24	150	3.2 JQ	710	10

Under Pier—Roto-sonic Boring Samples (at approx. -2 ft MLLW)													
DMMU Sampling Location		A18			B14			B15					
Sample ID		A18-01 ¹	A18-02	A18-03	B14-01	B-14-02	B14-03	X14-03 (dup)	B15-01 ¹	B15-02	B-15-03		
Sample Date		7/3/2014	7/3/2014	7/3/2014	7/3/2014	7/3/2014	7/3/2014	7/3/2014	7/3/2014	7/3/2014	7/3/2014		
Depth (bml)		7-9 ft	9-10 ft	11-13 ft	0-2 ft	2-3 ft	8-10 ft	8-10 ft	9-10 ft	11.5-13.5 ft	13.5-15.5 ft		
Chemical	Unit	DMMMP Criteria											
		SL	BT										
Tributyltin (Bulk)	µg/kg	73	73	3.4 U	3.5 U	3.5 U	4.7	4.8	3.7 U	3.7 U	18	3.5 U	3.6 U

Shoreline Cutback—North Area													
DMMU Sampling Location		C3			C4			C5					
Sample ID		C3-01	C3-02	C3-03	X3-01 (dup)	C4-01	C4-02	C4-03	C5-01	C5-02	C5-03		
Sample Date		7/9/2014	7/9/2014	7/9/2014	7/9/2014	7/9/2014	7/9/2014	7/9/2014	7/9/2014	7/9/2014	7/9/2014		
Depth (bml)		0-2 ft	2-4 ft	4-6 ft	4-6 ft	0-2 ft	2-4 ft	4-6 ft	0-2 ft	2-4 ft	4-6 ft		
Chemical	Unit	DMMMP Criteria											
		SL	BT										
Tributyltin (Bulk)	µg/kg	73	73	3.3 UJ	3.4 U	3.5 U	3.3 U	2.2 JQ	3.4 U	3.4 U	3.3 UJ	3.4 U	3.4 U

Shoreline Cutback—South Area										
DMMU Sampling Location		D3			D4					
Sample ID		D3-01	D3-02	D3-03	D4-01	D4-02	X4-02 (dup)	D4-03		
Sample Date		7/9/2014	7/9/2014	7/9/2014	7/9/2014	7/9/2014	7/9/2014	7/9/2014		
Depth (bml)		0-2 ft	2-4 ft	4-6 ft	0-2 ft	2-4 ft	2-4 ft	4-6 ft		
Chemical	Unit	DMMMP Criteria								
		SL	BT							
Tributyltin (Bulk)	µg/kg	73	73	3.4 U	3.6 U	3.6 U	3.3 U	3.5 U	3.4 U	3.3 U

Note:
Bold red Indicates an exceedance of DMMP criteria.

- Abbreviations:
- bml Below mudline
 - BT Bioaccumulation trigger
 - cm Centimeters
 - DMMP Dredged Material Management Program
 - DMMU Dredged Material Management Unit
 - ft Feet
 - µg/L Micrograms per liter
 - µg/kg Micrograms per kilogram
 - MLLW Mean lower low water
 - NA Not applicable
 - SL Screening level

- Qualifiers:
- J The analyte was detected; the concentration is considered an estimate.
 - JQ The analyte was detected between the method detection limit and the reporting limit; the concentration is considered an estimate.
 - U The analyte was not detected at the given reporting limit.
 - UJ The analyte was not detected; the concentration is the reporting limit, which is considered an estimate.

Table 2
Potential Sediment Suspension and Tributyltin Concentrations Results from Concrete Pile Extraction

Pier 4 Slope Concrete Pile Diameter	Perimeter Inches	Area per Foot of Pile (sf)	Thickness of Contaminated Layer (ft)	Contaminated Area of Pile (sf)	Thickness of Mud on Pile (inches)	Volume of Contaminated Sediment per Pile (cf)	Number of Concrete Piles Located within Contaminated Sediment	Total CY of Contaminated Sediment Potential Suspended	Area of Top of Slope Clean Material (SF)	Possible Thickness of TBT-Contaminated Sediments on Clean Material Area (inches)
16.5	54.6	4.6	10	45.5	0.25	0.95	691	24.3	43,400	0.18

Notes:

Gray shading indicates conservative contamination-related assumptions used for the calculation.

Bold Indicates key calculation results.

Abbreviations:

- cf Cubic feet
- CY Cubic yards
- ft Feet
- sf Square feet
- TBT Tributyltin

Figures



Notes:
 · Pier 4 location based on KPFF data.
 · Background aerial imagery provided by Esri, August 1, 2011.



FLOYD | SNIDER
 strategy ■ science ■ engineering

**Proposed Suitability of Phase 1 Clean Material
 Pier 4 Phase 1 Removal Action Project
 Tacoma, Washington**

Figure 1
 Site Location Map of Pier 4

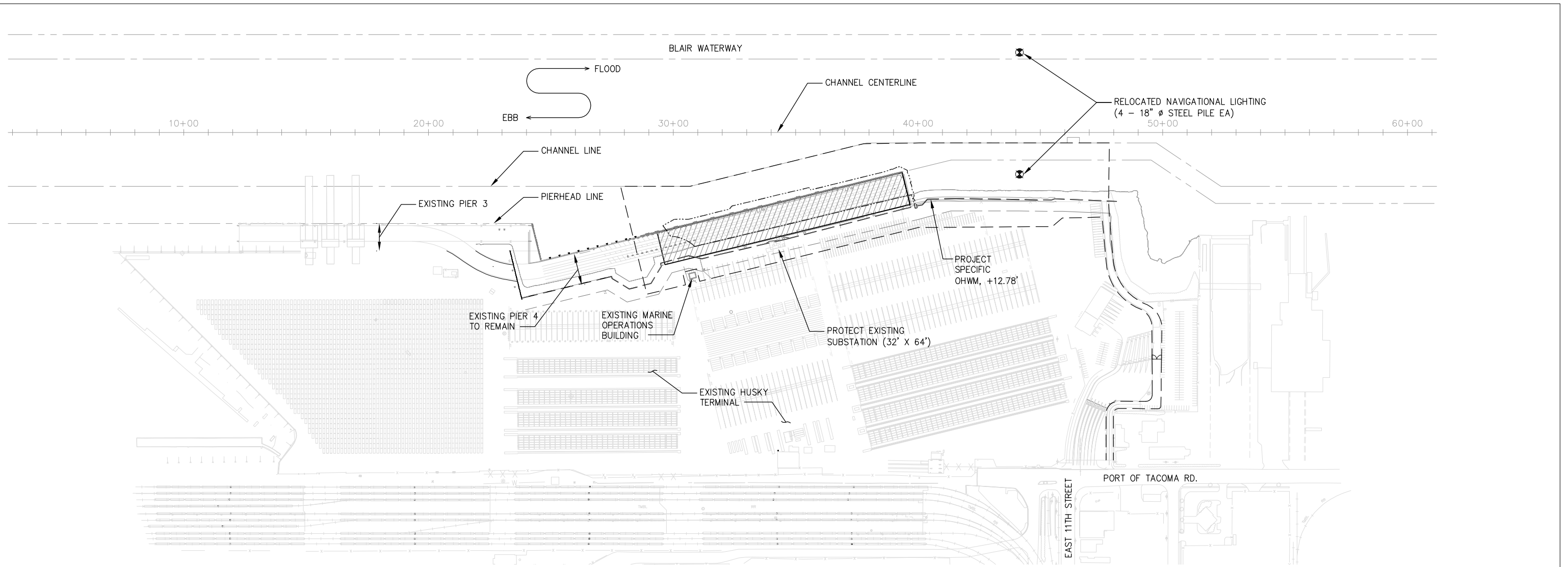

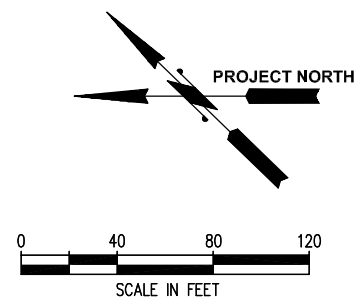

FIGURE 2 - SITE PLAN

SCALE: 1"=200'

LEGEND

- PROJECT WORK LIMITS
- - - - - LIMITS OF DREDGING REMOVAL ACTION
-  EXISTING PIER 4 DEMOLITION (140,550 SQ FT)



kpff Consulting Engineers

101 Stewart Street, Suite 400
 Seattle, Washington 98101
 (206) 382-0600 Fax (206) 382-0500

PROPOSED SUITABILITY OF PHASE 1 PROJECT
 CLEAN MATERIAL
 TACOMA, WASHINGTON
 FIGURE 2 - SITE PLAN

DATE: DECEMBER 2014 SCALE: 1" = 200'-0"

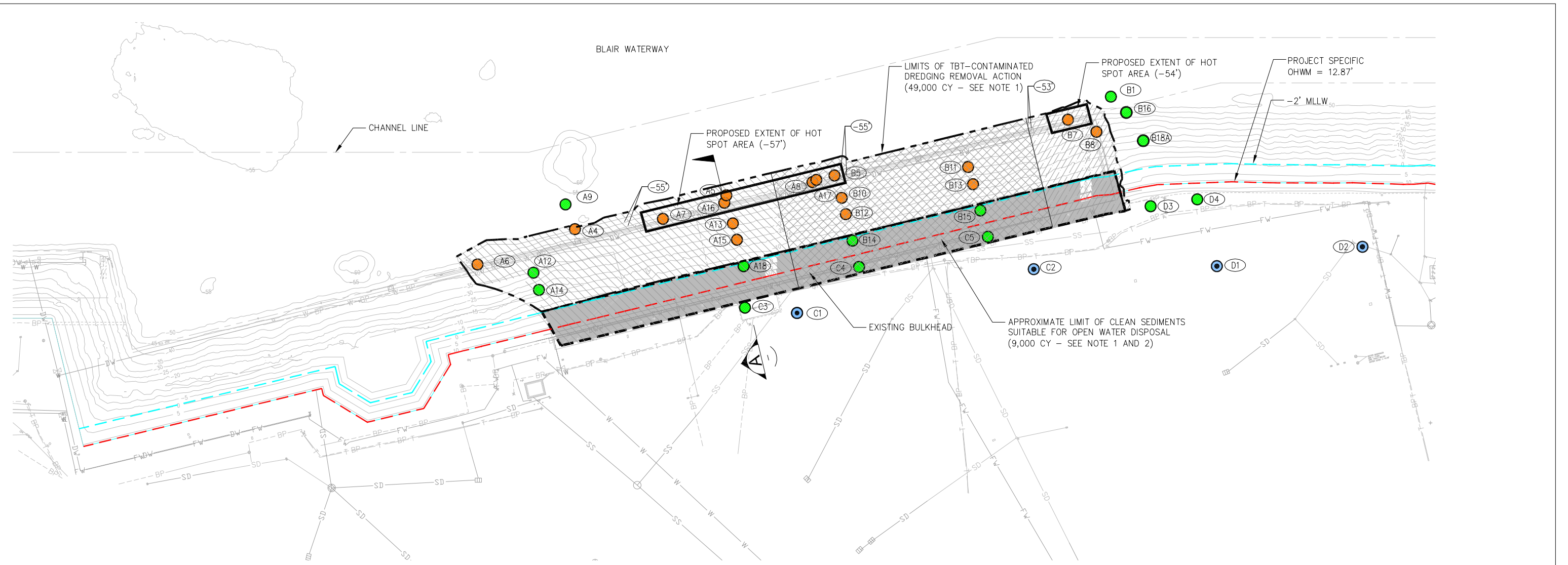

FIGURE 3 - PHASE 1 DREDGE PLAN

SCALE: 1"=150'

LEGEND

- EXISTING CONTOUR
- TOE OF DREDGE, SEE NOTE 3
- SAMPLE LOCATION
- DREDGE SEDIMENT ALONG DEMOLISHED PIER FACE TO -55' MLLW AND UPPER 9FT OF SLOPE, SEE NOTE 3
- DREDGE SEDIMENT ALONG DEMOLISHED PIER FACE TO -55' MLLW AND UPPER 11FT OF SLOPE, SEE NOTE 3
- DREDGE SEDIMENT ALONG DEMOLISHED PIER FACE TO -53' MLLW AND UPPER 8FT OF SLOPE, SEE NOTE 3
- CROSS SECTION LOCATION

- SAMPLE LOCATIONS WITH SEDIMENT SAMPLES CONTAINING TBT CONCENTRATIONS GREATER THAN THE DMMP SCREENING LEVEL OF 73 UG/KG
- SAMPLE LOCATIONS WHERE THERE ARE NO TBT EXCEEDANCES OF THE DMMP TBT SCREENING LEVEL (73 UG/KG) (SAMPLES ANALYZED FOR TBT ONLY)
- SAMPLE LOCATIONS WHERE THERE ARE NO CHEMICAL EXCEEDANCES OF THE DMMP SCREENING LEVELS FOR THE DMMP SUITE OF CHEMICALS OF CONCERN

NOTES

1. VOLUME IS APPROXIMATE AND INCLUDES THE 1-FOOT OVERDREDGE ALLOWANCE.
2. THE 2-FOOT RIP RAP ARMORED SLOPE MATERIAL (APPROXIMATELY 2,3000 CY) HAS BEEN DEDUCTED FROM THE VOLUME.
3. DREDGE DEPTHS DO NOT INCLUDE THE 1-FOOT OVERDREDGE ALLOWANCE.

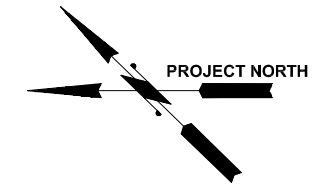

kpff Consulting Engineers

101 Stewart Street, Suite 400
 Seattle, Washington 98101
 (206) 382-0600 Fax (206) 382-0500

PROPOSED SUITABILITY OF PHASE 1 PROJECT
 CLEAN MATERIAL
 TACOMA, WASHINGTON
 FIGURE 3 - PHASE 1 DREDGE PLAN

DATE: DECEMBER 2014 SCALE: 1" = 150'-0"

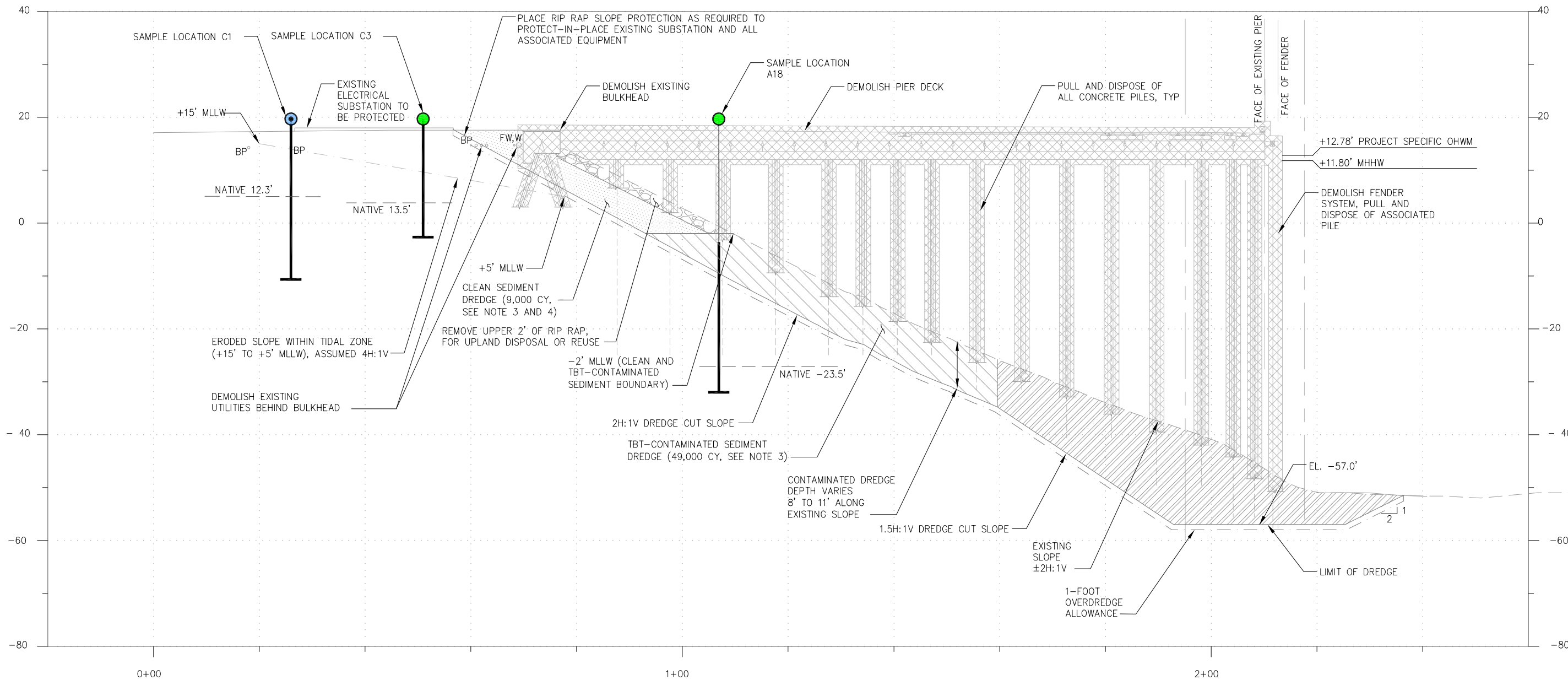



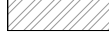



FIGURE 4 - DREDGE SECTION A
SCALE: 1"=10'

LEGEND:

-  EXISTING PIER TO BE DEMOLISHED DURING PHASE 1
-  APPROXIMATE LOCATION OF CONTAMINATED SEDIMENT TO BE DREDGED (49,000 CY)
-  APPROXIMATE LOCATION OF CLEAN SEDIMENT TO BE DREDGED (9,000 CY)
-  LOCAL HOT SPOT (INCLUDED IN 49,000 CY)
- BP BURIED POWER CONDUIT
- FW FIRE WATER LINE
- W WATER LINE

-  SAMPLE LOCATIONS WHERE THERE ARE NO TBT EXCEEDANCES OF THE DMMP TBT SCREENING LEVEL (73 UG/KG) (SAMPLES ANALYZED FOR TBT ONLY)
-  SAMPLE LOCATIONS WHERE THERE ARE NO CHEMICAL EXCEEDANCES OF THE DMMP SCREENING LEVELS FOR THE DMMP SUITE OF CHEMICALS OF CONCERN

NOTES:

1. THE BOUNDARY BETWEEN THE CLEAN, NON-TBT CONTAMINATED SEDIMENTS AND THE TBT-CONTAMINATED SEDIMENTS AT -2 FT MLLW IS BASED ON THE LOCATION OF UNDER-PIER SEDIMENT CORES WHERE THE RESULTS OF THE TBT CHEMICAL ANALYSIS OF COLLECTED SAMPLES SHOWED THAT TBT WAS NOT DETECTED OR DETECTED AT CONCENTRATIONS BELOW THE DMMP TBT SCREENING LEVEL OF 73 UG/KG.
2. ONLY SAMPLE LOCATIONS BOUNDING THE CONTAMINATED SEDIMENT FROM THE CLEAN SEDIMENT ARE SHOWN.
3. VOLUME IS APPROXIMATE AND INCLUDES THE 1-FOOT OVERDREDGE ALLOWANCE.
4. THE 2-FOOT RIP RAP ARMORED SLOPE MATERIAL (APPROXIMATELY 2,300 CY) HAS BEEN DEDUCTED FROM THE VOLUME.



101 Stewart Street, Suite 400
Seattle, Washington 98101
(206) 382-0600 Fax (206) 382-0500

**PROPOSED SUITABILITY OF PHASE 1 PROJECT
CLEAN MATERIAL
TACOMA, WASHINGTON
FIGURE 4 - DREDGE SECTION A**

DATE: DECEMBER 2014 SCALE: 1" = 10'-0"

**APPENDIX E -
ADMINISTRATIVE
SETTLEMENT AGREEMENT
AND ORDER ON CONCENT
FOR TIME CRITICAL REMOVAL
ACTION (AOC) (PENDING)**

UNITED STATES ENVIRONMENTAL
PROTECTION AGENCY REGION 10

IN THE MATTER OF:
BLAIR WATERWAY TBT SITE
Tacoma, Pierce County, WA

ADMINISTRATIVE SETTLEMENT
AGREEMENT AND ORDER ON
CONSENT FOR TIME CRITICAL
REMOVAL ACTION

PORT OF TACOMA,

Respondent

U.S. EPA Region 10
CERCLA Docket No. _____

Proceeding Under Sections 104, 106(a), 107
and 122 of the Comprehensive
Environmental Response, Compensation,
and Liability Act, as amended, 42 U.S.C. §§
9604, 9606(a), 9607 and 9622

TABLE OF CONTENTS

I.	JURISDICTION AND GENERAL PROVISIONS.....	3
II.	PARTIES BOUND.....	3
III.	DEFINITIONS.....	4
IV.	FINDINGS OF FACT.....	6
V.	CONCLUSIONS OF LAW AND DETERMINATIONS.....	7
VI.	SETTLEMENT AGREEMENT AND ORDER.....	8
VII.	DESIGNATION OF CONTRACTOR, PROJECT COORDINATOR, AND ON-SCENE COORDINATOR.....	8
VIII.	WORK TO BE PERFORMED.....	9
IX.	ACCESS.....	12
X.	ACCESS TO INFORMATION.....	13
XI.	RECORD RETENTION.....	14
XII.	COMPLIANCE WITH OTHER LAWS.....	15
XIII.	EMERGENCY RESPONSE AND NOTIFICATION OF RELEASES.....	15
XIV.	PAYMENT OF RESPONSE COSTS.....	16
XV.	DISPUTE RESOLUTION.....	17
XVI.	FORCE MAJEURE.....	18
XVII.	STIPULATED PENALTIES.....	19
XVIII.	COVENANTS BY EPA.....	21
XIX.	RESERVATIONS OF RIGHTS BY EPA.....	21
XX.	CONVENANTS BY RESPONDENT.....	23
XXI.	OTHER CLAIMS.....	23
XXII.	EFFECT OF SETTLEMENT/CONTRIBUTION.....	24
XXIII.	INDEMNIFICATION.....	25
XXIV.	INSURANCE.....	26
XXV.	FINANCIAL ASSURANCE.....	26
XXVI.	MODIFICATION.....	26
XXVII.	ADDITIONAL REMOVAL ACTION.....	26
XXVII.	NOTICE OF COMPLETION OF WORK.....	26
XXIX.	INTEGRATION/APPENDICES.....	27
XXX.	EFFECTIVE DATE.....	27

I. JURISDICTION AND GENERAL PROVISIONS

1. This Administrative Settlement Agreement and Order on Consent (“Settlement Agreement”) is entered into voluntarily by the United States Environmental Protection Agency (“EPA”) and Port of Tacoma (“Respondent”). This Settlement Agreement provides for the performance of a time critical removal action by Respondent and the reimbursement of certain response costs incurred by the United States at or in connection with the Blair Waterway TBT Site (the “Site”) generally located at Pier 4 on the Blair Waterway in Tacoma, Pierce County, Washington.

2. This Settlement Agreement is issued under the authority vested in the President of the United States by Sections 104, 106(a), 107 and 122 of the Comprehensive Environmental Response, Compensation, and Liability Act of 1980, 42 U.S.C. §§ 9604, 9606(a), 9607 and 9622, as amended (“CERCLA”). This authority was delegated to the Administrator of EPA on January 23, 1987, by Executive Order 12580, 52 Fed. Reg. 2926 (Jan. 29, 1987), and further delegated to Regional Administrators on May 11, 1994, by EPA Delegation Nos. 14-14-C (Administrative Actions Through Consent Orders) and 14-14-D (Cost Recovery Non-Judicial Agreements and Administrative Consent Orders). On April 20, 2013 this authority was further delegated (in R10-14-14-C) by the Region 10 Administrator to the Director of the Office of Environmental Cleanup, and then ultimately redelegated via R10-14-14-C(1) to the Emergency Management Program Manager.

3. EPA has notified the State of Washington (the “State”) of this action pursuant to Section 106(a) of CERCLA, 42 U.S.C. § 9606(a).

4. EPA and Respondent recognize that this Settlement Agreement has been negotiated in good faith and that the actions undertaken by Respondent in accordance with this Settlement Agreement do not constitute an admission of any liability. Respondent does not admit, and retains the right to controvert in any subsequent proceedings other than proceedings to implement or enforce this Settlement Agreement, the validity of the findings of facts, conclusions of law, and determinations in Sections IV (Findings of Fact) and V (Conclusions of Law and Determinations) of this Settlement Agreement. Respondent agrees to comply with and be bound by the terms of this Settlement Agreement and further agrees that it will not contest the basis or validity of this Settlement Agreement or its terms.

II. PARTIES BOUND

5. This Settlement Agreement applies to and is binding upon EPA and upon Respondent and its successors and assigns. Any change in ownership or corporate status of the Respondent including, but not limited to, any transfer of assets or real or personal property shall not alter Respondent’s responsibilities under this Settlement Agreement.

6. Respondent is responsible for carrying out all activities required by this Settlement Agreement.

7. Respondent shall provide a copy of this Order to each contractor hired to

perform the Work required by this Order and to each person representing Respondent with respect to the Site or the Work, and shall condition all contracts entered into hereunder upon performance of the Work in conformity with the terms of this Order. Respondent or its contractors shall provide written notice of the Order to all subcontractors hired to perform any portion of the Work by this Order. Respondent shall nonetheless be responsible for ensuring that its contractors perform the work in accordance with the terms of this Order.

III. DEFINITIONS

8. Unless otherwise expressly provided in this Settlement Agreement, terms used in this Settlement Agreement which are defined in CERCLA or in regulations promulgated under CERCLA shall have the meaning assigned to them in CERCLA or in such regulations. Whenever terms listed below are used in this Settlement Agreement or in the appendices attached hereto and incorporated hereunder, the following definitions shall apply:

a. "Action Memorandum" shall mean the EPA Action Memorandum relating to the Site signed on January 27, 2015, by the Regional Administrator, EPA Region 10, or his delegate, and all attachments thereto. The Action Memorandum is attached as Appendix B.

b. "CERCLA" shall mean the Comprehensive Environmental Response, Compensation, and Liability Act of 1980, as amended, 42 U.S.C. §§ 9601, *et seq.*

c. "Day" shall mean a calendar day. In computing any period of time under this Settlement Agreement, where the last day would fall on a Saturday, Sunday, or Federal holiday, the period shall run until the close of business of the next working day.

d. "Effective Date" shall be the effective date of this Settlement Agreement as provided in Section XXIX.

e. "EPA" shall mean the United States Environmental Protection Agency and any successor departments or agencies of the United States.

f. "EPA Hazardous Substance Superfund" shall mean the Hazardous Substance Superfund established by the Internal Revenue Code, 26 U.S.C. § 9507.

g. "Ecology" shall mean the Washington State Department of Ecology and any successor departments or agencies of the State.

h. "Future Response Costs" shall mean all costs, including, but not limited to, direct and indirect costs, that the United States incurs in reviewing or developing plans, reports, and other deliverables submitted pursuant to this Settlement Agreement, in overseeing implementation of the Work, or otherwise implementing, overseeing, or enforcing this Settlement Agreement, including but not limited to, payroll costs, contractor costs, travel costs, laboratory costs, the costs incurred pursuant to Section IX (Access) (including, but not limited to, the cost of attorney time and any monies paid to secure access

including, but not limited to, the amount of just compensation), Section XIII (Emergency Response and Notification of Releases), Paragraph 64 (Work Takeover), community involvement (including, but not limited to, the costs of any technical assistance grant under Section 117(e) of CERCLA, 42 U.S.C. § 9617(e), Section XV (Dispute Resolution), and all litigation costs. Future Response Costs shall also include Agency for Toxic Substances and Disease Registry (“ATSDR”) costs regarding the Site, all Interim Response Costs, and all Interest on those Past Response Costs Respondent has agreed to pay under this Settlement Agreement that has accrued pursuant to 42 U.S.C. § 9607(a) during the period prior to the Effective Date.

i. “Interest” shall mean interest at the rate specified for interest on investments of the EPA Hazardous Substance Superfund established by 26 U.S.C. § 9507, compounded annually on October 1 of each year, in accordance with 42 U.S.C. § 9607(a). The applicable rate of interest shall be the rate in effect at the time the interest accrues. The rate of interest is subject to change on October 1 of each year.

j. “Interim Response Costs” shall mean all costs, including direct and indirect costs, a) paid by the United States in connection with the Site between April 30, 2014 and the Effective Date, or b) incurred prior to the Effective Date, but paid after that date.

k. “National Contingency Plan” or “NCP” shall mean the National Oil and Hazardous Substances Pollution Contingency Plan promulgated pursuant to Section 105 of CERCLA, 42 U.S.C. § 9605, codified at 40 C.F.R. Part 300, and any amendments thereto.

l. “Paragraph” shall mean a portion of this Settlement Agreement identified by an Arabic numeral.

m. “Parties” shall mean EPA and Respondent.

n. “Past Response Costs” shall mean all costs, including, but not limited to, direct and indirect costs, that the United States paid at or in connection with the Site prior to the Effective Date, plus Interest on all such costs through such date, but excludes costs paid by Respondent pursuant to Parties’ Administrative Settlement and Order on Consent, CERCLA Docket No. 10-2014-0128, effective June 13, 2014.

o. “RCRA” shall mean the Solid Waste Disposal Act, as amended, 42 U.S.C. §§6901, *et seq.* (also known as the Resource Conservation and Recovery Act).

p. “Respondent” shall mean the Port of Tacoma. Respondent’s contacts are as follows:

For Technical Matters:
Scott Hooton
Port of Tacoma, Environmental Project Manager
PO Box 1837, Tacoma, WA 98401 – 1837
253-383-9428
shooton@portoftacoma.com

For Legal Matters:
Kimberly Seely
Coastline Law Group
4015 Ruston Way, Ste 200
Tacoma, WA 98403
253-203-6820
kseely@coastlinelaw.com

q. “Section” shall mean a portion of this Settlement Agreement identified by a Roman numeral.

r. “Settlement Agreement” shall mean this Administrative Settlement Agreement and Order on Consent and all appendices attached hereto (listed in Section XXVIII). In the event of conflict between this Settlement Agreement and any appendix, this Settlement Agreement shall control.

s. “Site” shall mean the Blair Waterway TBT Site, encompassing approximately 21 acres, located at Pier 4 on the Blair Waterway in Tacoma, Pierce County, Washington, and depicted generally on the map attached as Appendix A.

t. “Blair Waterway TBT Special Account” shall mean the special account within the EPA Hazardous Substance Superfund, established for the Site by EPA pursuant to Section 122(b)(3) of CERCLA, 42 U.S.C. § 9622(b)(3).

u. “State” shall mean the State of Washington.

v. “Statement of Work” or “SOW” shall mean the statement of work for implementation of the time critical removal action, as set forth in Appendix C to this Settlement Agreement, and any modifications made thereto in accordance with this Settlement Agreement.

w. “United States” shall mean the United States of America and each department, agency, and instrumentality of the United States, including EPA.

x. “Waste Material” shall mean 1) any “hazardous substance” under Section 101(14) of CERCLA, 42 U.S.C. § 9601(14); 2) any pollutant or contaminant under Section 101(33) of CERCLA, 42 U.S.C. § 9601(33); 3) any “solid waste” under Section 1004(27) of RCRA, 42 U.S.C. § 6903(27); and 4) any “hazardous substance” under Section 70.105D.010(10) of the Model Toxics Control Act (“MTCA”).

y. “Work” shall mean all activities Respondent is required to perform under this Settlement Agreement.

IV. FINDINGS OF FACT

EPA makes the following Findings of Fact, without any express or implied admissions of such facts by Respondent:

9. Respondent is owner of Pier 4, a deep water terminal located on the Blair Waterway in Tacoma, Pierce County, Washington.

10. In 2013, Respondent conducted sediment sampling events under and at Pier 4 pursuant to the Dredge Material Management Program (“DMMP”). This sampling was necessary to characterize sediments for purposes of a dredging project involving the reconfiguration of Pier 4.

11. Tributyltin (“TBT”) is a hazardous substance as that term is defined under CERCLA, RCRA and MTCA, and constitutes waste material as defined in Section III.u above. TBT was encountered at levels exceeding the DMMP TBT screening level at some locations within or near the projected dredge prism. TBT at these levels may render approximately 40,000 cubic yards of sediments unsuitable for open water disposal or beneficial use.

12. To further investigate the presence of TBT at the Site, Respondent conducted investigation activities under an Administrative Settlement and Order on Consent, CERCLA Docket No. 10-2014-0128, effective June 13, 2014. Results of such activities were documented in a Removal Site Evaluation Report (RSER).

13. Based on findings documented in the RSER, EPA completed an Action Memorandum, executed on January 27, 2015, attached hereto as Appendix B and incorporated into this Settlement Agreement by reference. The Action Memorandum concludes that a Time Critical Removal Action is appropriate at this Site.

14. Project tasks conducted under this Settlement Agreement may be eligible for a remedial action grant through Ecology’s grant program. Reimbursement eligibility for project tasks conducted under this Settlement Agreement is contingent upon the determination by Ecology’s Toxic Cleanup Program that the work performed complies with the substantive requirements of Chapter 173-340 WAC and is consistent with the removal activities required under this Settlement Agreement.

V. CONCLUSIONS OF LAW AND DETERMINATIONS

15. Based on the Findings of Fact set forth above, and the Administrative Record supporting these removal activities, EPA has determined that:

a. The Blair Waterway TBT Site is a “facility” as defined by Section 101(9) of CERCLA, 42 U.S.C. § 9601(9).

b. The contamination found at the Site, as identified in the Findings of Fact above, includes “hazardous substances” as defined by Section 101(14) of CERCLA, 42 U.S.C. § 9601(14).

c. Respondent is a “person” as defined by Section 101(21) of CERCLA, 42 U.S.C. § 9601(21).

d. Respondent is a responsible party under Section 107(a) of CERCLA, 42 U.S.C. § 9607(a), and is jointly and severally liable for performance of response action and for response costs incurred and to be incurred at the Site. Respondent is the “owner” and/or “operator” of the facility, as defined by Section 101(20) of CERCLA, 42 U.S.C. § 9601(20), and within the meaning of Section 107(a)(1) of CERCLA, 42 U.S.C. § 9607(a)(1)..

e. The conditions described in Paragraphs 9-14 of the Findings of Fact above constitute an actual or threatened of “release” of a hazardous substance from the facility as defined by Section 101(22) of CERCLA, 42 U.S.C. § 9601(22).

f. The conditions at the Site may present an imminent and substantial endangerment to the public health or welfare or the environment within the meaning of Section 106(a) of CERCLA, 42 U.S.C. § 9606(a).

g. The removal activities required by this Settlement Agreement are necessary to protect the public health, welfare, or the environment and, if carried out in compliance with the terms of this Settlement Agreement, will be consistent with the NCP, as provided in Section 300.700(c)(3)(ii) of the NCP.

VI. SETTLEMENT AGREEMENT AND ORDER

Based upon the foregoing Findings of Fact, Conclusions of Law, Determinations, and the Administrative Record for this Site, it is hereby Ordered and Agreed that Respondent shall comply with all provisions of this Settlement Agreement, including, but not limited to, all attachments to this Settlement Agreement and all documents incorporated by reference into this Settlement Agreement.

VII. DESIGNATION OF CONTRACTOR, PROJECT COORDINATOR, AND ON-SCENE COORDINATOR

16. Respondent has retained, and EPA has not disapproved, Floyd/Snider Environmental Consultants to perform the Work with respect to drafting of planning documents. Respondent shall also notify EPA of the name(s) and qualification(s) of any other contractor(s) or subcontractor(s) retained to perform the Work at least 14 days prior to commencement of such Work. EPA retains the right to disapprove of any or all of the contractors and/or subcontractors retained by Respondent. If EPA disapproves of a selected contractor, Respondent shall retain a different contractor and shall notify EPA of that contractor’s name and qualifications within 30 days of EPA’s disapproval.

a. EPA recognizes that Respondent must select contractors pursuant to statutory requirements applicable to port districts set forth under Public Contracts and Indebtedness Title 39 RCW and Title 53 RCW. As such, if EPA disapproves of a selected contractor and Respondent cannot retain a different contractor within the required 30 days, upon proof of good faith effort by Respondent, EPA may extend this deadline by an additional 30 days.

17. Respondent has retained, and EPA has not disapproved the following individual as Project Coordinator, who shall be responsible for administration of all planning actions by

Respondent required by this Settlement Agreement: Ms. Jessi Massingale, PE, of Floyd Snider, 601 Union Street, Suite 600, Seattle, WA 98101, 206-292-2078, jessi.massingale@floydsnider.com. To the greatest extent possible, the Project Coordinator shall be present on Site or readily available during Site work. EPA retains the right to disapprove of the designated Project Coordinator. If EPA disapproves of the designated Project Coordinator, Respondent shall retain a different Project Coordinator and shall notify EPA of that person's name, address, telephone number, and qualifications within 14 days following EPA's disapproval. Notice or communication relating to this Settlement Agreement from EPA to Respondent's Project Coordinator shall constitute notice or communication to Respondent. EPA and Respondent shall have the right, subject to Paragraph 16, to change their respective designated OSC or Project Coordinator. Respondent shall notify EPA 10 days before such a change is made. The initial notification by Respondent may be made orally, but shall be promptly followed by a written notice.

18. EPA has designated Kathy Parker, of the EPA Region 10 Emergency Management Program Branch, as its On-Scene Coordinator ("OSC"). Except as otherwise provided in this Settlement Agreement, Respondent shall direct all submissions required by this Settlement Agreement to the OSC at USEPA Region 10, 1200 Sixth Ave., Suite 900, MS: ECL-133, Seattle, WA 98101. Respondent shall submit one paper and one electronic copy of all plans, reports, or other deliverables required by this Settlement Agreement, the Statement of Work, or any approved work plan. All data evidencing Site conditions shall be submitted to EPA in electronic form. Sampling and monitoring data contained in any deliverables must be submitted in CLP-type Electronic Data Deliverable ("EDD") format.

19. The OSC shall be responsible for overseeing Respondent's implementation of this Settlement Agreement. The OSC shall have the authority vested in an OSC by the NCP, including the authority to halt, conduct, or direct any Work required by this Settlement Agreement, or to direct any other removal action undertaken at the Site. Absence of the OSC from the Site shall not be cause for stoppage of work unless specifically directed by the OSC.

VIII. WORK TO BE PERFORMED

20. Respondent shall perform, at a minimum, all actions necessary to implement the Statement of Work. The actions to be implemented generally include, but are not limited to, the following:

- a. Preparation of a Removal Action Work Plan, including a schedule and work to be performed to accomplish the removal action. The Removal Action Work Plan shall include as appendices: 1) a Water Quality Monitoring and Protection Plan; 2) a Dredge Water Treatment Compliance Sampling Plan; and 3) a Post-Dredge Confirmation Sampling Plan and associated Health and Safety Plan.;
- b. Implementation of the Time Critical Removal Action consistent with the Removal Action Work Plan; and
- c. Preparation and approval of a Time Critical Removal Action Report, which summarizes work performed, monitoring and confirmational sampling conducted, and provides waste disposal documentation.

21. Work Plan and Implementation.

a. Within 30 days after the Effective Date, Respondent shall submit to EPA for approval the draft Removal Action Work Plan for performing the removal action generally described in Paragraph 20 above, and detailed more specifically in the SOW. The draft Work Plan shall provide a description of, and an expeditious schedule for, the actions required by this Settlement Agreement.

b. EPA may approve, disapprove, require revisions to, or modify the draft Work Plan in whole or in part. If EPA requires revisions, Respondent shall submit a revised draft Work Plan within 14 days of receipt of EPA's notification of the required revisions. Respondent shall implement the Work Plan as approved in writing by EPA in accordance with the schedule approved by EPA. Once approved, or approved with modifications, the Work Plan, the schedule, and any subsequent modifications shall be incorporated into and become fully enforceable under this Settlement Agreement.

c. Upon approval of the Removal Action Work Plan Respondent shall commence implementation of the Work in accordance with the schedule included therein. Respondent shall not commence any Work except in conformance with the terms of this Settlement Agreement.

d. Unless otherwise provided in this Settlement Agreement, any additional plans, reports, or other deliverables that require EPA approval under the SOW or Removal Action Work Plan shall be reviewed and approved by EPA in accordance with this Paragraph.

22. Health and Safety Plan. Prior to starting construction/dredging work, Respondent's contractor shall submit for EPA review and comment a plan that ensures the protection of the public health and safety during performance of on-site work under this Settlement Agreement. This plan shall be prepared in accordance with EPA's Standard Operating Safety Guide (PUB 9285.1-03, PB 92-963414, June 1992). In addition, the plan shall comply with all currently applicable Occupational Safety and Health Administration ("OSHA") regulations found at 29 C.F.R. Part 1910. If EPA determines that it is appropriate, the plan shall also include contingency planning. Respondent's contractor shall incorporate all changes to the plan recommended by EPA and shall implement the plan during the pendency of the removal action.

23. Quality Assurance Sampling, and Data Analysis.

a. Respondent shall use quality assurance, quality control, and other technical activities and chain of custody procedures for all samples consistent with "EPA Requirements for Quality Assurance Project Plans (QA/R5)" (EPA/240/B-01/003, March 2001, reissued May 2006), "Guidance for Quality Assurance Project Plans (QA/G-5)" (EPA/240/R-02/009, December 2002), and subsequent amendments to such guidelines upon notification by EPA to Respondent of such amendment. Amended guidelines shall apply only to procedures conducted after such notification.

b. In accordance with the Post-Dredge Confirmation Sampling Plan, Respondent shall submit to EPA for approval a Quality Assurance Project Plan (“QAPP”) that is consistent with the SOW, the NCP, and applicable guidance documents. Respondent shall ensure that EPA personnel and its authorized representatives are allowed access at reasonable times to all laboratories utilized by Respondent in implementing this Settlement Agreement. In addition, Respondent shall ensure that such laboratories shall analyze all samples submitted by EPA pursuant to the QAPP for quality assurance, quality control, and technical activities that will satisfy the stated performance criteria as specified in the QAPP. Respondent shall ensure that the laboratories it utilizes for the analysis of samples taken pursuant to this Settlement Agreement perform all analyses according to accepted EPA methods. Accepted EPA methods consist of, but are not limited to, methods that are documented in the EPA’s Contract Laboratory Program (<http://www.epa.gov/superfund/programs/clp/>), SW 846 “Test Methods for Evaluating Solid Waste, Physical/Chemical Methods” (<http://www.epa.gov/epawaste/hazard/testmethods/sw846/online/index.htm>), “Standard Methods for the Examination of Water and Wastewater” (<http://www.standardmethods.org/>), 40 C.F.R. Part 136, “Air Toxics - Monitoring Methods” (<http://www.epa.gov/ttnamti1/airtox.html>),” and any amendments made thereto during the course of the implementation of this Settlement Agreement. However, upon approval by EPA, Respondent may use other appropriate analytical method(s), as long as (a) quality assurance/quality control (“QA/QC”) criteria are contained in the method(s) and the method(s) are included in the QAPP, (b) the analytical method(s) are at least as stringent as the methods listed above, and (c) the method(s) have been approved for use by a nationally recognized organization responsible for verification and publication of analytical methods, e.g., EPA, ASTM, NIOSH, OSHA, etc. Respondent shall ensure that all laboratories it uses for analysis of samples taken pursuant to this Settlement Agreement have a documented Quality System that complies with ANSI/ASQC E-4-2004, “Quality Systems for Environmental Data and Technology Programs: Requirements with Guidance for Use” (American National Standard, and “EPA Requirements for Quality Management Plans (QA/R-2)” (EPA/240/B-01/002, March 2001, reissued May 2006), or equivalent documentation as determined by EPA. EPA may consider Environmental Response Laboratory Network (“ERLN”) laboratories, laboratories accredited under the National Environmental Laboratory Accreditation Program (“NELAP”), or laboratories that meet International Standardization Organization (ISO 17025) standards or other nationally recognized programs (<http://www.epa.gov/fem/accredit.htm>) as meeting the Quality System requirements. Respondent shall ensure that all field methodologies utilized in collecting samples for subsequent analysis pursuant to this Settlement Agreement are conducted in accordance with the procedures set forth in the QAPP approved by EPA.

c. Upon request, Respondent shall provide split or duplicate samples to EPA or its authorized representatives. Respondent shall notify EPA not less than 7 days in advance of any sample collection activity unless shorter notice is agreed to by EPA. In addition, EPA shall have the right to take any additional samples that EPA deems necessary. Upon request, EPA shall provide to Respondent split or duplicate samples of any samples it takes as part of EPA’s oversight of Respondent’s implementation of the Work.

d. Respondent shall submit to EPA the results of all sampling and/or tests or other data obtained or generated by or on behalf of Respondent with respect to the Site and/or the implementation of this Settlement Agreement.

e. Notwithstanding any provision of this Settlement Agreement, the United States retains all of its information gathering and inspection authorities and rights, including enforcement actions related thereto, under CERCLA, RCRA, and any other applicable statutes and regulations.

24. Reporting.

a. Respondent shall submit a written progress report to EPA concerning actions undertaken pursuant to this Settlement Agreement every 30th day after the date of receipt of EPA's approval of the Work Plan until issuance of Notice of Completion of Work pursuant Section XXVI, unless otherwise directed in writing by the OSC. These reports shall describe all significant developments during the preceding period, including the actions performed and any problems encountered, analytical data received during the reporting period, and the developments anticipated during the next reporting period, including a schedule of actions to be performed, anticipated problems, and planned resolutions of past or anticipated problems.

b. Respondent shall submit one paper and one electronic copy of all plans, reports or other submissions required by this Settlement Agreement, the Statement of Work, or any approved work plan.

25. Final Report. Within 90 days after completion of all Work required by this Settlement Agreement, other than continuing obligations required by Paragraph 94 (Notice of Completion), Respondent shall submit for EPA review and approval the Time Critical Removal Action Report summarizing the actions taken to comply with this Settlement Agreement. The Report shall conform, at a minimum, with the requirements set forth in Section 300.165 of the NCP entitled "OSC Reports." The Report shall also include the following certification signed by a responsible corporate official of Respondent or Respondent's Project Coordinator: "I certify under penalty of law that this document and all attachments were prepared under my direction or supervision in accordance with a system designed to assure that qualified personnel properly gather and evaluate the information submitted. Based on my inquiry of the person or persons who manage the system, or those persons directly responsible for gathering the information, the information submitted is, to the best of my knowledge and belief, true, accurate, and complete. I am aware that there are significant penalties for submitting false information, including the possibility of fine and imprisonment for knowing violations."

a. Interim Approval of Dredging Completion. EPA recognizes that this Time Critical Removal Action is part of a larger construction project involving the realignment of Pier 4. To further continuation of the construction project and avoid delay, EPA agrees to issue a Memorandum to the Port stating that the dredging work has been completed to EPA's satisfaction, although such Memorandum shall in no way compromise EPA's rights under Sections XIX (Reservation of Rights by EPA), XXVI (Modification), XXVIII (Additional Removal Action), or XXVII (Notice of Completion of Work) of this Settlement Agreement.

IX. ACCESS

26. If the Site, or any other real property where access and/or land, water, or other resource use restrictions are needed, is owned or controlled by Respondent:

a. Respondent shall, commencing on the Effective Date, provide the United States and their representatives, contractors, and subcontractors, with access at all reasonable times to the Site, or such other real property, to conduct any activity regarding the Settlement Agreement including, but not limited to, the following activities:

- (1) Monitoring the Work;
- (2) Verifying any data or information submitted to EPA;
- (3) Conducting investigations regarding contamination at or near the Site;
- (4) Obtaining samples;
- (5) Assessing the need for, planning, or implementing additional response actions at or near the Site;
- (6) Assessing implementation of quality assurance and quality control practices as defined in the approved QAPP;
- (7) Implementing the Work pursuant to the conditions set forth in Paragraph 64 (Work Takeover);
- (8) Inspecting and copying records, operating logs, contracts, or other documents maintained or generated by Respondent or its agents, consistent with Section X (Access to Information);
- (9) Assessing Respondent's compliance with the Settlement Agreement; and
- (10) Determining whether the Site or other real property is being used in a manner that is prohibited or restricted, or that may need to be prohibited or restricted under the Settlement Agreement.

27. Where any action under this Settlement Agreement is to be performed in areas owned by or in possession of someone other than Respondent, Respondent shall use its best efforts to obtain all necessary access agreements within 30 days after the Effective Date, or as otherwise specified in writing by the OSC. Respondent shall immediately notify EPA if after using its best efforts, Respondent is unable to obtain such agreements. For purposes of this Paragraph, "best efforts" includes the payment of reasonable sums of money in consideration of access. Respondent shall describe in writing its efforts to obtain access. EPA may then assist Respondent in gaining access, to the extent necessary to effectuate the response actions described in this Settlement Agreement, using such means as EPA deems appropriate. Respondent shall reimburse EPA for all costs incurred, direct or indirect, by the United States in obtaining such access, including, but not limited to, the cost of attorney time and the amount of monetary consideration, in accordance with the procedures in Section XV (Payment of Response Costs).

28. Notwithstanding any provision of this Settlement Agreement, EPA retains all of its access authorities and rights, including enforcement authorities related thereto, under CERCLA, RCRA, MTCA, and any other applicable statutes or regulations.

X. ACCESS TO INFORMATION

29. Respondent shall provide to EPA, upon request, copies of all records, reports, documents and information (including records, reports, documents, and other information in electronic form) (hereinafter referred to as “Records”) within its possession or control or that of its contractors or agents relating to activities at the Site or to the implementation of this Settlement Agreement, including, but not limited to, sampling, analysis, chain of custody records, manifests, trucking logs, receipts, reports, sample traffic routing, correspondence, or other documents or information related to the Work. Respondent shall also make available to EPA, for purposes of investigation, information gathering, or testimony, its employees, agents, or representatives with knowledge of relevant facts concerning the performance of the Work.

30. Privileged and Protected Claims.

a. Respondent may assert that all or part of a Record requested by EPA is privileged or protected as provided under federal law, in lieu of providing the Record, provided Respondent complies with Paragraph 30.b and except as provided in Paragraph 30.c.

b. If Respondent asserts such a privilege or protection, it shall provide EPA with the following information regarding such Record: its title; its date; the name, title, affiliation (e.g., company or firm), and address of the author, of each addressee, and of each recipient; a description of the Record’s contents; and the privilege or protection asserted. If a claim of privilege or protection applies only to a portion of a Record, the Record shall be provided to EPA in redacted form to mask the privileged or protected portion only. Respondent shall retain all Records that it claims to be privileged or protected until EPA has had a reasonable opportunity to dispute the privilege or protection claim and any such dispute has been resolved in Respondent’s favor.

c. Respondent may make no claim of privilege or protection regarding:

- (1) any data regarding the Site, including, but not limited to, all sampling, analytical, monitoring, hydrogeologic, scientific, chemical, radiological, or engineering data, or the portion of any other Record that evidence conditions at or around the Site; or
- (2) the portion of any Record that Respondent is required to create or generate pursuant to this Settlement Agreement.

31. **Business Confidential Claims.** Respondent may assert that all or part of a Record provided to EPA under this Section or Section XI (Retention of Records) is business confidential to the extent permitted by and in accordance with Section 104(e)(7) of CERCLA, 42 U.S.C. § 9604(e)(7), and 40 C.F.R. § 2.203(b). Respondent shall segregate and clearly identify all Records or parts thereof submitted under this Settlement Agreement for which

Respondent assert business confidentiality claims. Records submitted to EPA determined to be confidential by EPA will be afforded the protection specified in 40 C.F.R. Part 2, Subpart B. If no claim of confidentiality accompanies Records when they are submitted to EPA, or if EPA has notified Respondent that the Records are not confidential under the standards of Section 104(e)(7) of CERCLA or 40 C.F.R. Part 2, Subpart B, the public may be given access to such Records without further notice to Respondent.

32. Notwithstanding any provision of this Settlement Agreement, EPA retains all of its information gathering and inspection authorities and rights, including enforcement actions related thereto, under CERCLA, RCRA, MTCA, and any other applicable statutes or regulations.

XI. RECORD RETENTION

33. Until 10 years after EPA provides Respondent with notice, pursuant to Section XXVI (Notice of Completion of Work), that all Work has been fully performed in accordance with this Settlement Agreement, Respondent shall preserve and retain all non- identical copies of records and documents (including records or documents in electronic form) now in its possession or control or which come into its possession or control that relate in any manner its liability under CERCLA with respect to the Site. Respondent must also retain, and instruct its contractors and agents to preserve, for the same period of time specified above all non-identical copies of the last draft or final version of any Records (including Records in electronic form) now in its possession or control or that come into its possession or control that relate in any manner to the performance of the Work, provided, however, that Respondent (and its contractors and agents) must retain, in addition, copies of all data generated during the performance of the Work and not contained in the aforementioned Records required to be retained. Each of the above record retention requirements shall apply regardless of any corporate retention policy to the contrary. As used herein, Respondent's obligation to "possess" and "retain" may include Respondent's records storage at a secure off site location. As used herein, Respondent's obligation to "possess" and "retain" may include Respondent's records storage at a secure off site location.

34. At the conclusion of the document retention period, as described in Paragraph 33 herein or such longer period as may be required under applicable law, Respondent shall notify EPA at least 90 days prior to the destruction of any Records, and, upon request by EPA, and except as provided in Paragraph 30 (Privileged and Protected Claims), Respondent shall deliver any such records or documents to EPA.

35. Respondent hereby certifies that to the best of its knowledge and belief, after thorough inquiry, it has not altered, mutilated, discarded, destroyed or otherwise disposed of any records, documents or other information (other than identical copies) relating to its potential liability regarding the Site since notification of potential liability by EPA, and that it has fully complied with any and all EPA requests for information pursuant to Sections 104(e) and 122(e) of CERCLA, 42 U.S.C. §§9604(e) and 9622(e), and Section 3007 of RCRA, 42 U.S.C. § 6927 and State law.

XII. COMPLIANCE WITH OTHER LAWS

36. Nothing in this Settlement Agreement limits Respondent's obligations to comply with the requirements of all applicable state and federal laws and regulations, except as provided in Section 121(e) of CERCLA, 42 U.S.C. § 6921(e), and 40 C.F.R. §§ 300.400(e) and 300.415(j). In accordance with 40 C.F.R. § 300.415(j), all on-Site actions required pursuant to this Settlement Agreement shall, to the extent practicable, as determined by EPA, considering the exigencies of the situation, attain applicable or relevant and appropriate requirements ("ARARs") under federal environmental or state environmental or facility siting laws. Respondents shall identify ARARs in the Work Plan subject to EPA approval.

XIII. EMERGENCY RESPONSE AND NOTIFICATION OF RELEASES

37. Emergency Response. In the event any action or occurrence during performance of the Work causes or threatens a release of Waste Material from the Site that constitutes an emergency situation or may present an immediate threat to public health or welfare or the environment, Respondent shall immediately take all appropriate action. Respondent shall take these actions in accordance with all applicable provisions of this Settlement Agreement, including, but not limited to, the Health and Safety Plan, in order to prevent, abate or minimize such release or endangerment caused or threatened by the release. Respondent shall also immediately notify the OSC or, in the event of his/her unavailability, the Regional Duty Officer at the Region 10 Emergency Management Program Branch at (206) 553-1264, and the EPA National Response Center at (800) 424-8802, of the incident or Site conditions. In the event that Respondent fails to take appropriate response action as required by this Paragraph, and EPA takes such action instead, Respondent shall reimburse EPA all costs of the response action not inconsistent with the NCP pursuant to Section XIV (Payment of Response Costs).

38. In addition, in the event of any release of a hazardous substance from the Site, Respondent shall immediately notify the OSC at (206) 553-1264, and the National Response Center at (800) 424-8802. Respondent shall submit a written report to EPA within 7 days after each release, setting forth the events that occurred and the measures taken or to be taken to mitigate any release or endangerment caused or threatened by the release and to prevent the reoccurrence of such a release. This reporting requirement is in addition to, and not in lieu of, reporting under Section 103(c) of CERCLA, 42 U.S.C. § 9603(c), and Section 304 of the Emergency Planning and Community Right-To-Know Act of 1986, 42 U.S.C. § 11004, *et seq.*

XIV. PAYMENT OF RESPONSE COSTS

39. Payment of Response Costs. Respondent agrees to pay Past and Interim Response Costs not previously billed under the Administrative Settlement and Order on Consent, CERCLA Docket No. 10-2014-0128, effective June 13, 2014. Respondent shall also pay EPA all Future Response Costs not inconsistent with the NCP. On a periodic basis, EPA will send Respondent a bill requiring payment that includes a cost summary report, which includes direct and indirect costs incurred by EPA, its contractors, subcontractors, and the United States Department of Justice. Respondent shall make all payments within 60 days after Respondent's receipt of each bill requiring payment

40. Method of Payment.

- a. Payment shall be made to EPA by Fedwire Electronic Funds Transfer (“EFT”) to:

Federal Reserve Bank of New York
ABA = 021030004
Account = 68010727
SWIFT address = FRNYUS33
33 Liberty Street
New York, NY 10045
Field Tag 4200 of the Fedwire message should read “D 68010727
Environmental Protection Agency”

and shall reference the name and address of the party making the payment as well as the Site/Spill ID Number 10MY and the EPA docket number for this action.

- b. At the time of payment, Respondent shall send notice that payment has been made to the EPA Cincinnati Finance Office by email at acctsreceivable.cinwd@epa.gov, or by mail to:

EPA Cincinnati Finance Office
26 Martin Luther King Drive
Cincinnati, Ohio 45268

Such notice shall reference Site/Spill ID Number 10MY and the EPA docket number for this action.

41. Interest. In the event that payment of any (Past, Interim or Future) Response Costs are not made within 60 days of Respondent’s receipt of a bill, Respondent shall pay Interest on the unpaid balance. The Interest shall begin to accrue on the date of the bill and shall continue to accrue until the date of payment. Payments of Interest made under this Paragraph shall be in addition to such other remedies or sanctions available to the United States by virtue of Respondent’s failure to make timely payments under this Section, including but not limited to, payment of stipulated penalties pursuant to Section XVII.

42. Respondent may submit a Notice of Dispute, initiating the procedures of Section XV (Dispute Resolution) regarding payment of any (Past, Interim or Future) Response Costs billed under Paragraphs 39 and 40 if it determines that EPA has made a mathematical error, or if it believes EPA incurred excess costs as a direct result of an EPA action that was inconsistent with the NCP. Such Notice of Dispute shall be submitted in writing within 60 days of receipt of the bill and must be sent to the OSC. Any such Notice of Dispute shall specifically identify the contested Past, Interim or Future Response Costs and the basis for objection. If Respondent submits a Notice of Dispute, Respondent shall within the 60-day period pay all uncontested Response Costs to EPA in the manner described in Paragraph 40. Simultaneously, Respondent shall establish, in a duly chartered bank or trust company, an interest-bearing escrow account that is insured by the Federal Deposit Insurance Corporation (“FDIC”), and remit to that escrow account funds equivalent to the amount of the contested Response Costs. Respondent shall send to the OSC a copy of the transmittal letter and check paying the uncontested Response Costs, and a copy of the correspondence that establishes and funds the escrow account, including, but not limited to, information containing the

identity of the bank and bank account under which the escrow account is established as well as a bank statement showing the initial balance of the escrow account. If EPA prevails in the dispute, within 5 days of the resolution of the dispute, Respondent shall pay the sums due (with accrued interest) to EPA in the manner described in Paragraph 40. If Respondent prevails concerning any aspect of the contested costs, Respondent shall pay that portion of the costs (plus associated accrued interest) for which it did not prevail to EPA in the manner described in Paragraph 40. Respondent shall be disbursed any balance of the escrow account. The dispute resolution procedures set forth in this Paragraph in conjunction with the procedures set forth in Section XV (Dispute Resolution) shall be the exclusive mechanisms for resolving disputes regarding Respondent's obligation to reimburse EPA for its Past, Interim or Future Response Costs.

XV. DISPUTE RESOLUTION

43. Unless otherwise expressly provided for in this Settlement Agreement, the dispute resolution procedures of this Section shall be the exclusive mechanism for resolving disputes arising under this Settlement Agreement. The Parties shall attempt to resolve any disagreements concerning this Settlement Agreement expeditiously and informally.

44. Informal Dispute Resolution. If Respondent objects to any EPA action taken pursuant to this Settlement Agreement, excluding billings for Past, Interim or Future Response Costs, it shall send EPA a written Notice of Dispute describing the objection(s) within 30 days of such action. If Respondent objects to EPA action taken related to billing for Past, Interim or Future Response Costs, it shall send such notice within 60 days, consistent with Paragraph 42, above. EPA and Respondent shall have 30 days from EPA's receipt of Respondent's Notice of Dispute to resolve the dispute through informal negotiations (the "Negotiation Period"). The Negotiation Period may be extended at the sole discretion of EPA. Any agreement reached by the Parties pursuant to this Section shall be in writing and shall, upon signature by the Parties, be incorporated into and become an enforceable part of this Settlement Agreement.

45. Formal Dispute Resolution. If the Parties are unable to reach an agreement within the Negotiation Period, Respondent shall, within 20 days after the end of the Negotiation Period, submit a statement of position to the OSC. EPA may, within 20 days thereafter, submit a statement of position. Thereafter, the Director of the EPA Region 10 Office of Environmental Cleanup will issue a written decision on the dispute to Respondent. EPA's decision shall be incorporated into and become an enforceable part of this Settlement Agreement. Following resolution of the dispute, as provided by this Section, Respondent shall fulfill the requirement that was the subject of the dispute in accordance with the agreement reached or with EPA's decision, whichever occurs.

46. The invocation of formal dispute resolution procedures under this Section shall not extend, postpone, or affect in any way any obligation of Respondent under this Settlement Agreement, not directly in dispute, unless EPA provides otherwise in writing. Stipulated penalties with respect to the disputed matter shall continue to accrue but payment shall be stayed pending resolution of the dispute as provided in Paragraph 55. Notwithstanding the stay of payment, stipulated penalties shall accrue from the first day of noncompliance with any

applicable provision of this Settlement Agreement. In the event that Respondent does not prevail on the disputed issue, stipulated penalties shall be assessed and paid as provided in Section XVII (Stipulated Penalties).

XVI. FORCE MAJEURE

47. “Force Majeure” for purposes of this Settlement Agreement, is defined as any event arising from causes beyond the control of Respondent, of any entity controlled by Respondent, or of Respondent’s contractors that delays or prevents the performance of any obligation under this Settlement Agreement despite Respondent’s best efforts to fulfill the obligation. The requirement that Respondent exercises “best efforts to fulfill the obligation” includes using best efforts to anticipate any potential force majeure and best efforts to address the effects of any potential force majeure (a) as it is occurring and (b) following the potential force majeure such that the delay and any adverse effects of the delay are minimized to the greatest extent possible. “Force majeure” does not include financial inability to complete the Work, or increased cost of performance.

48. If any event occurs or has occurred that may delay the performance of any obligation under this Settlement Agreement for which Respondent intends or may intend to assert a claim of force majeure, Respondent shall notify EPA’s OSC orally or, in his or her absence, the alternate EPA OSC, or, in the event both of EPA’s designated representatives are unavailable, the Director of the Emergency Management Program Branch, EPA Region 10, within 72 hours of when Respondent first knew that the event might cause a delay. Within 10 days thereafter, Respondent shall provide in writing to EPA an explanation and description of the reasons for the delay; the anticipated duration of the delay; all actions taken or to be taken to prevent or minimize the delay; a schedule for implementation of any measures to be taken to prevent or mitigate the delay or the effect of the delay; Respondent’s rationale for attributing such delay to a force majeure; and a statement as to whether, in the opinion of Respondent, such event may cause or contribute to an endangerment to public health or welfare, or the environment. Respondent shall include with any notice all available documentation supporting their claim that the delay was attributable to a force majeure. Respondent shall be deemed to know of any circumstance of which Respondent, any entity controlled by Respondent, or Respondent’s contractors knew or should have known. Failure to comply with the above requirements regarding an event shall preclude Respondent from asserting any claim of force majeure regarding that event, provided, however, that if EPA, despite the late or incomplete notice, is able to assess to its satisfaction whether the event is a force majeure under Paragraph 47 and whether Respondent has exercised its best efforts under Paragraph 47, EPA may, in its unreviewable discretion, excuse in writing Respondent’s failure to submit timely or complete notices under this Paragraph.

49. If EPA agrees that the delay or anticipated delay is attributable to a force majeure, the time for performance of the obligations under this Settlement Agreement that are affected by the force majeure event will be extended by EPA for such time as is necessary to complete those obligations. An extension of the time for performance of the obligations affected by the force majeure event shall not, of itself, extend the time for performance of any other obligation. If EPA does not agree that the delay or anticipated delay has been or will be caused by a force majeure event, EPA will notify Respondent in writing of its decision. If EPA agrees that the delay is attributable to a force majeure event, EPA will notify

Respondent in writing of the length of the extension, if any, for performance of the obligations affected by the force majeure.

50. If Respondent elects to invoke the dispute resolution procedures set forth in Section XV (Dispute Resolution), it shall do so no later than 15 days after receipt of EPA's notice. In any such proceeding, Respondent shall have the burden of demonstrating by a preponderance of the evidence that the delay or anticipated delay has been or will be caused by a force majeure, that the duration of the delay or the extension sought was or will be warranted under the circumstances, that best efforts were exercised to avoid and mitigate the effects of the delay, and that Respondent complied with the requirements of Paragraphs 47 and 48. If Respondent carries this burden, the delay at issue shall be deemed not to be a violation by Respondent of the affected obligation of this Settlement Agreement identified to EPA.

XVII. STIPULATED PENALTIES

51. Respondent shall be liable to EPA for stipulated penalties in the amounts set forth in Paragraphs 52 and 53 for failure to comply with the requirements of this Settlement Agreement specified below, unless excused under Section XVI (Force Majeure). "Compliance" by Respondent shall include completion of all payments and activities required under this Settlement Agreement, or any plan, report, or other deliverable approved under this Settlement Agreement, in accordance with all applicable requirements of law, this Settlement Agreement, the SOW, and any plans, reports, or other deliverables approved under this Settlement Agreement and within the specified time schedules established by and approved under this Settlement Agreement.

52. Stipulated Penalty Amounts – Work (Including Payments and Excluding Plans, Reports, and Other Deliverables.

a. The following stipulated penalties shall accrue per violation per day for failure to submit timely or adequate reports or other deliverables, or any noncompliance identified in this Paragraph:

<u>Penalty Per Violation Per Day</u>	<u>Period of Noncompliance</u>
\$200.00	1st through 14th day
\$500.00	15th through 30th day
\$1,000.00	31st day and beyond

b. Compliance Milestones

- (1) Failure to timely submit modifications requested by EPA or its representatives to the draft Work Plan;
- (2) Failure to timely submit payment for Past, Interim or Future Response Costs required by Paragraphs 39 and 40;

(3) Failure to obtain insurance as required by Paragraph 82; and

(4) Failure to comply with any schedule in the EPA-approved Work Plan.

53. Stipulated Penalty Amounts – Plans, Reports, and Other Deliverables. The following stipulated penalties shall accrue per violation per day for failure to submit timely or adequate reports or other written documents pursuant to this Settlement Agreement:

<u>Penalty Per Violation Per Day</u>	<u>Period of Noncompliance</u>
<u>\$100.00</u>	1st through 14th day
<u>\$250.00</u>	15th through 30th day
<u>\$500.00</u>	31st day and beyond

54. In the event that EPA assumes performance of all or any portion(s) of the Work pursuant to Paragraph 64 (Work Takeover), Respondent shall be liable for a stipulated penalty in the amount of \$20,000.00.

55. All penalties shall begin to accrue on the day after the complete performance is due or the day a violation occurs, and shall continue to accrue through the final day of the correction of the noncompliance or completion of the activity. However, stipulated penalties shall not accrue: a) with respect to a deficient submission under Paragraph 21 (Work Plan and Implementation), during the period, if any, beginning on the 31st day after EPA's receipt of such submission until the date that EPA notifies Respondent of any deficiency; and b) with respect to a decision by the Director of the Office of Environmental Cleanup for Region 10 of EPA, under Paragraph 45 of Section XV (Dispute Resolution), during the period, if any, beginning on the 21st day after the Negotiation Period begins until the date that the EPA management official issues a final decision regarding such dispute. Nothing in this Settlement Agreement shall prevent the simultaneous accrual of separate penalties for separate violations of this Settlement Agreement. Penalties shall continue to accrue during any dispute resolution period, and shall be paid within 15 days after the agreement or the receipt of EPA's decision or order.

56. Following EPA's determination that Respondent has failed to comply with a requirement of this Settlement Agreement, EPA may give Respondent written notification of the failure and describe the noncompliance. EPA may send Respondent a written demand for payment of the penalties. However, penalties shall accrue as provided in the preceding Paragraph regardless of whether EPA has notified Respondent of a violation.

57. All penalties accruing under this Section shall be due and payable to EPA within 30 days of Respondent's receipt from EPA of a demand for payment of the penalties, unless Respondent invokes the dispute resolution procedures under Section XV (Dispute Resolution). All payments to EPA under this Section shall indicate that the payment is for stipulated penalties and shall be made in accordance with Paragraph 39 (Payment of Response Costs).

58. Nothing in this Settlement Agreement shall be construed as prohibiting, altering, or in any way limiting the ability of EPA to seek any other remedies or sanctions available by virtue of Respondent's violation of this Settlement Agreement or of the statutes and regulations

upon which it is based, including, but not limited to, penalties pursuant to Section 122(l) of CERCLA, 42 U.S.C. § 9622(l), provided however, that the EPA shall not seek civil penalties pursuant to Section 122(l) of CERCLA for any violation for which a stipulated penalty is provided in this Settlement Agreement, except in the case of a willful violation of this Settlement Agreement.

59. The payment of penalties and Interest, if any, shall not alter in any way Respondent's obligation to complete performance of the Work required under this Settlement Agreement.

60. Notwithstanding any other provision of this Section, EPA may, in its unreviewable discretion, waive any portion of stipulated penalties that have accrued pursuant to this Settlement Agreement.

XVIII. COVENANTS BY EPA

61. In consideration of the actions that will be performed and the payments that will be made by Respondent under the terms of this Settlement Agreement, and except as otherwise specifically provided in this Settlement Agreement, EPA covenants not to sue or to take administrative action against Respondent pursuant to Sections 106 and 107(a) of CERCLA, 42 U.S.C. §§ 9606 and 9607(a), for the Work, Past Response Costs, and Future Response Costs. These covenants shall take effect upon receipt by EPA of the payment due under Section XIV (Payment of Response Costs) of this Settlement Agreement and any Interest or Stipulated Penalties due thereon under Paragraph 41 (Interest) or Section XVII (Stipulated Penalties). These covenants are conditioned upon the complete and satisfactory performance by Respondent of its obligations under this Settlement Agreement, including, but not limited to, payment of Past, Interim or Future Response Costs pursuant to Section XV. These covenants extend only to Respondent and do not extend to any other person.

XIX. RESERVATIONS OF RIGHTS BY EPA

62. Except as specifically provided in this Settlement Agreement, nothing in this Settlement Agreement shall limit the power and authority of EPA or the United States to take, direct, or order all actions necessary to protect public health, welfare, or the environment or to prevent, abate, or minimize an actual or threatened release of hazardous substances, pollutants or contaminants, or hazardous or solid waste on, at, or from the Site. Further, nothing in this Settlement Agreement shall prevent EPA from seeking legal or equitable relief to enforce the terms of this Settlement Agreement, from taking other legal or equitable action as it deems appropriate and necessary, or from requiring Respondent in the future to perform additional activities pursuant to CERCLA or any other applicable law.

63. The covenants not to sue set forth in Section XVIII (Covenants by EPA) above do not pertain to any matters other than those expressly identified therein. EPA reserves, and this Settlement Agreement is without prejudice to, all rights against Respondent with respect to all other matters, including, but not limited to:

a. liability for failure by Respondent to meet a requirement of this Settlement Agreement;

- b. liability for costs not included within the definitions of Past, Interim or Future Response Costs;
- c. liability for performance of response action other than the Work;
- d. criminal liability;
- e. liability for damages for injury to, destruction of, or loss of natural resources, and for the costs of any natural resource damage assessments;
- f. liability arising from the past, present, or future disposal, release or threat of release of Waste Materials outside of the Site;
- g. liability for violations of federal or state law that occur during or after implementation of the Work; and
- h. liability for costs incurred or to be incurred by the Agency for Toxic Substances and Disease Registry related to the Site not paid as Future Response Costs under this Settlement Agreement.

64. Work Takeover. In the event EPA determines that Respondent has ceased implementation of any portion of the Work, is seriously or repeatedly deficient or late in its performance of the Work, or is implementing the Work in a manner which may cause an endangerment to human health or the environment, EPA may issue a written notice (“Work Takeover Notice”) to Respondent and assume the performance of all or any portion(s) of the Work as EPA deems necessary (“Work Takeover”). Any Work Takeover Notice issued by EPA (which writing may be electronic) will specify the grounds upon which such notice was issued. Respondent may invoke the procedures set forth in Section XV (Dispute Resolution) to dispute EPA’s determination that takeover of the Work is warranted under this Paragraph. However, notwithstanding Respondent’s invocation of such dispute resolution procedures, and during the pendency of any such dispute, EPA may in its sole discretion commence and continue a Work Takeover until the earlier of the date that Respondent remedies, to EPA’s satisfaction, the circumstances giving rise to EPA’s issuance of the relevant Work Takeover Notice, or the date that a written decision terminating such Work Takeover is rendered in accordance with Paragraph 45.

XX. COVENANTS BY RESPONDENT

65. Respondent covenants not to sue and agrees not to assert any claims or causes of action against the United States, or its contractors or employees, with respect to the Work, Future Response Costs, or this Settlement Agreement, including, but not limited to:

- a. any direct or indirect claim for reimbursement from the Hazardous Substance Superfund established by 26 U.S.C. § 9507, based on Sections 106(b)(2),

107, 111, 112, or 113 of CERCLA, 42 U.S.C. §§ 9606(b)(2), 9607, 9611, 9612, or 9613, or any other provision of law;

b. any claim arising out of response actions at or in connection with the Site, including any claim under the United States Constitution, the Washington State Constitution, the Tucker Act, 28 U.S.C. § 1491, the Equal Access to Justice Act, 28 U.S.C. § 2412, as amended, or at common law; or

c. any claim against the United States pursuant to Sections 107 and 113 of CERCLA, 42 U.S.C. §§ 9607 and 9613, relating to the Work, or Future Response Costs.

66. Except as provided in Paragraph 69 (Claims Against De Micromis Parties), these covenants not to sue shall not apply in the event the United States brings a cause of action or issues an order pursuant to any of the reservations set forth in Section XIX (Reservations of Rights by EPA), other than in Paragraph 63.a (liability for failure to meet a requirement of the Settlement Agreement) or 63.d (criminal liability), but only to the extent that Respondent's claim arises from the same response action, response costs, or damages that the United States is seeking pursuant to the applicable reservation.

67. Nothing in this Agreement shall be deemed to constitute approval or preauthorization of a claim within the meaning of Section 111 of CERCLA, 42 U.S.C. § 9611, or 40 C.F.R. § 300.700(d).

68. Respondent reserves, and this Settlement Agreement is without prejudice to, claims against the United States, subject to the provisions of Chapter 171 of Title 28 of the United States Code, and brought pursuant to any statute other than CERCLA or RCRA and for which the waiver of sovereign immunity is found in a statute other than CERCLA or RCRA, for money damages for injury or loss of property or personal injury or death caused by the negligent or wrongful act or omission of any employee of the United States, as that term is defined in 28 U.S.C. § 2671, while acting within the scope of his or her office or employment under circumstances where the United States, if a private person, would be liable to the claimant in accordance with the law of the place where the act or omission occurred. However, the foregoing shall not include any claim based on EPA's selection of response actions, or the oversight or approval of Respondent's plans, reports, other deliverables or activities.

69. Claims Against De Micromis Parties. Respondent agrees not to assert any claims and to waive all claims or causes of action (including but not limited to claims or causes of action under Sections 107(a) and 113 of CERCLA) that it may have for all matters relating to the Site against any person where the person's liability to Respondent with respect to the Site is based solely on having arranged for disposal or treatment, or for transport for disposal or treatment, of hazardous substances at the Site, or having accepted for transport for disposal or treatment of hazardous substances at the Site, if all or part of the disposal, treatment, or transport occurred before April 1, 2001, and the total amount of material containing hazardous substances contributed by such person to the Site was less than 110 gallons of liquid materials or 200 pounds of solid materials.

70. The waiver in Paragraph 69 shall not apply with respect to any defense, claim, or cause of action that Respondent may have against any person meeting the above criteria if such person asserts a claim or cause of action relating to the Site against Respondent. This waiver also shall not apply to any claim or cause of action against any person meeting the above criteria if EPA determines: (a) that such person has failed to comply with any EPA requests for information or administrative subpoenas issued pursuant to Section 104(e) or 122(e) of CERCLA, 42 U.S.C. §§ 9604(e) or 9622(e), or Section 3007 of RCRA, 42 U.S.C. § 6972, or has impeded or is impeding, through action or inaction, the performance of a response action or natural resource restoration with respect to the Site, or has been convicted of a criminal violation for the conduct to which this waiver would apply and that conviction has not been vitiated on appeal or otherwise; or (b) that the materials containing hazardous substances contributed to the Site by such person have contributed significantly, or could contribute significantly, either individually or in the aggregate, to the cost of response action or natural resource restoration at the Site.

XXI. OTHER CLAIMS

71. By issuance of this Settlement Agreement, the United States and EPA assume no liability for injuries or damages to persons or property resulting from any acts or omissions of Respondent. The United States or EPA shall not be deemed a party to any contract entered into by Respondent or its directors, officers, employees, agents, successors, representatives, assigns, contractors, or consultants in carrying out actions pursuant to this Settlement Agreement.

72. Except as expressly provided in Section XVIII (Covenants by EPA), nothing in this Settlement Agreement constitutes a satisfaction of or release from any claim or cause of action against Respondent or any person not a party to this Settlement Agreement, for any liability such person may have under CERCLA, other statutes, or common law, including but not limited to any claims of the United States for costs, damages, and interest under Sections 106 and 107 of CERCLA, 42 U.S.C. §§ 9606 and 9607.

73. No action or decision by EPA pursuant to this Settlement Agreement shall give rise to any right to judicial review, except as set forth in Section 113(h) of CERCLA, 42 U.S.C. § 9613(h).

XXII. EFFECT OF SETTLEMENT/CONTRIBUTION

74. Nothing in this Settlement Agreement shall be construed to create any rights in, or grant any cause of action to, any person not a Party to this Settlement Agreement. Except as provided in Section XX (Covenants by Respondent), each of the Parties expressly reserves any and all rights (including, but not limited to, pursuant to Section 113 of CERCLA, 42 U.S.C. § 9613), defenses, claims, demands, and causes of action which each Party may have with respect to any matter, transaction, or occurrence relating in any way to the Site against any person not a Party hereto. Nothing in this Settlement Agreement diminishes the right of the United States, pursuant to Section 113(f)(2) and (3) of CERCLA, 42 U.S.C. § 9613(f)(2)-(3), to pursue any such persons to obtain additional response costs or response action and to enter into settlements that give rise to contribution protection pursuant to Section 113(f)(2).

75. The Parties agree that this Settlement Agreement constitutes an administrative settlement for purposes of Sections 113(f)(2) and 122(h)(4) of CERCLA, 42 U.S.C. §§ 9613(f)(2) and 9622(h)(4), and that Respondent is entitled, as of the Effective Date, to protection from contribution actions or claims as provided by Sections 113(f)(2) and 122(h)(4) of CERCLA, 42 U.S.C. §§ 9613(f)(2) and 9622(h)(4), or as may be otherwise provided by law, for “matters addressed” in this Settlement Agreement. The “matters addressed” in this Settlement Agreement are the Work and Past, Future Response Costs. The Parties further agree that this Settlement Agreement constitutes an administrative settlement for purposes of Section 113(f)(3)(B) of CERCLA, 42 U.S.C. § 9613(f)(3)(B), pursuant to which Respondent has, as of the Effective Date, resolved its liability to the United States for the Work and Past, Interim or Future Response Costs.

76. Respondent shall, with respect to any suit or claim brought by it for matters related to this Settlement Agreement, notify EPA in writing no later than 60 days prior to the initiation of such suit or claim. Respondent also shall, with respect to any suit or claim brought against it for matters related to this Settlement Agreement, notify EPA in writing within 10 days after service of the complaint or claim upon it. In addition, Respondent shall notify EPA within 10 days after service or receipt of any Motion for Summary Judgment and within 10 days after receipt of any order from a court setting a case for trial, for matters related to this Settlement Agreement.

77. In any subsequent administrative or judicial proceeding initiated by EPA, or by the United States on behalf of EPA, for injunctive relief, recovery of response costs, or other relief relating to the Site, Respondent shall not assert, and may not maintain, any defense or claim based upon the principles of waiver, res judicata, collateral estoppel, issue preclusion, claim-splitting, or other defenses based upon any contention that the claims raised in the subsequent proceeding were or should have been brought in the instant case; provided, however, that nothing in this Paragraph affects the enforceability of the covenant by EPA set forth in Section XVIII (Covenants By EPA).

78. Effective upon signature of this Settlement Agreement by Respondent, Respondent agrees that the time period commencing on the date of its signature and ending on the date EPA receives from Respondent the payments required by Section XIV (Payment of Response Costs) and, if any, Section XVII (Stipulated Penalties) shall not be included in computing the running of any statute of limitations potentially applicable to any action brought by the United States related to the “matters addressed” as defined in Paragraph 75 and that, in any action brought by the United States related to the “matters addressed,” Respondent will not assert, and may not maintain, any defense or claim based upon principles of statute of limitations, waiver, laches, estoppel, or other defense based on the passage of time during such period. If EPA gives notice to Respondent that it will not make this Settlement Agreement effective, the statute of limitations shall begin to run again commencing ninety days after the date such notice is sent by EPA.

XXIII. INDEMNIFICATION

79. Respondent shall indemnify, save and hold harmless the United States, its officials, agents, contractors, subcontractors, employees and representatives from any and all claims or causes of action arising from, or on account of, negligent or other wrongful acts or omissions of Respondent, its officers, directors, employees, agents, contractors, or

subcontractors, in carrying out actions pursuant to this Settlement Agreement. In addition, Respondent agrees to pay the United States all costs incurred by the United States, including but not limited to attorneys fees and other expenses of litigation and settlement, arising from or on account of claims made against the United States based on negligent or other wrongful acts or omissions of Respondent, its officers, directors, employees, agents, contractors, subcontractors and any persons acting on its behalf or under its control, in carrying out activities pursuant to this Settlement Agreement. The United States shall not be held out as a party to any contract entered into by or on behalf of Respondent in carrying out activities pursuant to this Settlement Agreement. Neither Respondent nor any such contractor shall be considered an agent of the United States.

80. The United States shall give Respondent notice of any claim for which the United States plans to seek indemnification pursuant to this Section and shall consult with Respondent prior to settling such claim.

81. Respondent waives all claims against the United States for damages or reimbursement or for set-off of any payments made or to be made to the United States, arising from or on account of any contract, agreement, or arrangement between Respondent and any person for performance of Work on or relating to the Site, including, but not limited to, claims on account of construction delays. In addition, Respondent shall indemnify and hold harmless the United States with respect to any and all claims for damages or reimbursement arising from or on account of any contract, agreement, or arrangement between Respondent and any person for performance of Work on or relating to the Site, including, but not limited to, claims on account of construction delays.

XXIV. INSURANCE

82. At least 14 days prior to commencing any on-Site work under this Settlement Agreement, Respondent shall secure, and shall maintain for the duration of this Settlement Agreement, commercial general liability insurance with limits of \$3.5 million dollars, for any one occurrence, and automobile insurance with limits of \$1 million dollars, combined single limit, naming EPA as an additional insured with respect to all liability arising out of the activities performed by or on behalf of Respondent pursuant to this Settlement Agreement. Within the same time period, Respondent shall provide EPA with certificates of such insurance no later than 14 days prior to commencing on-Site work, and a copy of each insurance policy as soon as it becomes available. Respondent shall submit such certificates and copies of policies each year on the anniversary of the Effective Date, or as soon as they become available thereafter. In addition, for the duration of the Settlement Agreement, Respondent shall satisfy, or shall ensure that their contractors or subcontractors satisfy, all applicable laws and regulations regarding the provision of worker's compensation insurance for all persons performing the Work on behalf of Respondent in furtherance of this Settlement Agreement. If Respondent demonstrates by evidence satisfactory to EPA that any contractor or subcontractor maintains insurance equivalent to that described above, or insurance covering some or all of the same risks but in an equal or lesser amount, then Respondent need provide only that portion of the insurance described above which is not maintained by such contractor or subcontractor.

XXV. FINANCIAL ASSURANCE

83. In order to ensure completion of the Work, Respondent shall establish, maintain, and submit to EPA financial assurance, initially in the amount of \$18,500,000.00 (the “Estimated Cost of the Work”), for the benefit of EPA. The financial assurance, which must be satisfactory in form and substance to EPA, shall be in the form of one or more of the following mechanisms (provided that, if Respondent intends to use multiple mechanisms, such multiple mechanisms shall be limited to surety bonds, letters of credit, trust funds, and insurance policies).

a. A surety bond that provides EPA with acceptable rights as a beneficiary thereof unconditionally guaranteeing payment and/or performance of the Work;

b. An irrevocable letter of credit, payable to or at the direction of EPA, that is issued by an entity that has the authority to issue letters of credit and whose letter-of-credit operations are regulated and examined by a federal or state agency;

c. A trust fund established for the benefit of EPA that is administered by a trustee acceptable in all respects to EPA;

d. A policy of insurance that provides EPA with acceptable rights as a beneficiary thereof, is issued by an insurance carrier acceptable in all respects to EPA, and ensures the payment and/or performance of the Work;

e. A demonstration by Respondent that such Respondent meets the financial test criteria of 40 C.F.R. § 264.143(f) with respect to the Estimated Cost of the Work (plus the amount(s) of any other federal, state, or tribal environmental obligations financially assured through the use of a financial test or guarantee), provided that all other requirements of 40 C.F.R. § 264.143(f) and this Section are satisfied; and/or

f. A written guarantee to fund or perform the Work executed in favor of EPA provided by one or more of the following: (1) a direct or indirect parent company of Respondent, or (2) a company that has a “substantial business relationship” (as defined in 40 C.F.R. § 264.141(h)) with Respondent; provided, however, that any company providing such a guarantee must demonstrate to the satisfaction of EPA that it satisfies the financial test and reporting requirements for owners and operators set forth in subparagraphs (1) through (8) of 40 C.F.R. § 264.143(f) and this Section with respect to the Estimated Cost of the Work (plus the amount(s) of any other federal, state, or tribal environmental obligations financially assured through the use of a financial test or guarantee).

84. Within 30 days after the Effective Date, Respondent shall submit all executed or otherwise finalized mechanisms or other documents required, to Kathy Parker, US EPA Region 10, 1200 Sixth Street, M/S ORC-113, Seattle, WA 98101.

85. If Respondent provides or obtains financial assurance for completion of the Work by means of a demonstration or guarantee pursuant to Paragraph 83.e or 83.f, Respondent and/or its guarantors shall also comply with the other relevant requirements of 40 C.F.R. § 264.143(f) relating to these mechanisms unless otherwise provided in this Settlement Agreement, and with the requirements of this Section, including but not limited to: (a) the initial submission of required financial reports and statements from the relevant entity’s chief

financial officer and independent certified public accountant to EPA no later than 30 days after the Effective Date; (b) the annual re-submission of such reports and statements within 90 days after the close of each such entity's fiscal year; and (c) the notification of EPA no later than 30 days after any such entity determines that it no longer satisfies the financial test requirements set forth at 40 C.F.R. § 264.143(f)(1) and in any event within 90 days after the close of any fiscal year for which the year-end financial data show that such entity no longer satisfies such financial test requirements. Respondent agrees that EPA may also, based on a belief that the relevant entity may no longer meet the financial test requirements of this Section, require reports of financial condition at any time from the relevant entity in addition to those specified in this Section. For purposes of the financial assurance mechanisms specified in this Section, references in 40 C.F.R. Part 264, Subpart H to: (1) the terms "current closure cost estimate," "current post-closure cost estimate," and "current plugging and abandonment cost estimate" shall also include the Estimated Cost of the Work; (2) "the sum of current closure and post-closure cost estimates and the current plugging and abandonment cost estimates" shall mean "the sum of all environmental obligations" (including obligations under CERCLA, RCRA, EPA's Underground Injection Control program, 40 C.F.R. Part 144, enacted as part of the Solid Waste Disposal Act, 42 U.S.C. §§ 6901 to 6992k, the Toxic Substances Control Act, 15 U.S.C. §§ 2601 to 2695d, and any other federal, state, or tribal environmental obligation) guaranteed by Respondent or for which Respondent is otherwise financially obligated in addition to the Estimated Cost of the Work to be performed in accordance with this Settlement Agreement; (3) the terms "owner" and "operator" shall be deemed to refer to Respondent obtaining a guarantee or making a demonstration under Paragraph 83.e or 83.f; and (4) the terms "facility" and "hazardous waste management facility" shall be deemed to include the Site.

86. Respondent shall diligently monitor the adequacy of the financial assurance. In the event that EPA determines and so notifies Respondent, or Respondent becomes aware of information indicating, that financial assurance provided pursuant to this Section is inadequate or otherwise no longer satisfies the requirements set forth in this Section, whether due to an increase in the estimated cost of completing the Work or for any other reason, Respondent shall notify EPA of the inadequacy within 30 days and, within 30 days after providing to or receiving from EPA such notice, shall obtain and submit to EPA for approval a proposal for a revised or alternative form of financial assurance that satisfies the requirements set forth in this Section. If EPA approves the proposal, Respondent shall provide a revised or alternate financial assurance mechanism in compliance with and to the extent permitted by such written approval and shall submit all documents evidencing such change to EPA pursuant to the delivery instructions in Paragraph 81 within 30 days after receipt of EPA's written approval. In seeking approval for a revised or alternate form of financial assurance, Respondent shall follow the procedures set forth in Paragraph 88. If EPA does not approve the proposal, Respondent shall follow the procedures set forth in Paragraph 88 to obtain and submit to EPA for approval another proposal for a revised or alternate form of financial assurance within 30 days after receipt of EPA's written disapproval.

87. The issuance of a Work Takeover Notice pursuant to Paragraph 64 (Work Takeover) shall trigger EPA's right to receive the benefit of any financial assurance(s) provided pursuant to this Section. At such time, EPA shall have the right to enforce performance by the issuer of the relevant financial assurance mechanism and/or immediately access resources guaranteed under any such mechanism, whether in cash or in kind, as needed to continue and complete all or any portion(s) of the Work assumed by EPA. In the event (a) EPA is unable to promptly secure the resources guaranteed under any such financial assurance

mechanism, whether in cash or in kind, necessary to continue and complete the Work assumed by EPA, or (b) the financial assurance involves a demonstration of satisfaction of the financial test criteria pursuant to Paragraph 83.e or 83.f, Respondent shall immediately upon written demand from EPA deposit into an account specified by EPA, in immediately available funds and without setoff, counterclaim, or condition of any kind, a cash amount up to but not exceeding the estimated cost of the remaining Work to be performed as of such date, as determined by EPA. All EPA Work Takeover costs not paid pursuant to this Paragraph shall be reimbursed under Section XIV (Payment of Response Costs). In addition, if at any time EPA is notified by the issuer of a financial assurance mechanism that such issuer intends to cancel the financial assurance mechanism it has issued, then, unless Respondent provides an alternate financial assurance mechanism in accordance with this Section no later than 30 days prior to the impending cancellation date, EPA shall be entitled (as of and after the date that is 30 days prior to the impending cancellation) to draw fully on the funds guaranteed under the then-existing financial assurance.

88. Respondent shall not reduce the amount of, or change the form or terms of, the financial assurance until Respondent receives written approval from EPA to do so. Respondent may petition EPA in writing to request such a reduction or change on any anniversary of the Effective Date, or at any other time agreed to by the Parties. Any such petition shall include the estimated cost of the remaining Work and the basis upon which such cost was calculated, and, for proposed changes to the form or terms of the financial assurance, the proposed revision(s) to the form or terms of the financial assurance. If EPA notifies Respondent that it has approved the requested reduction or change, Respondent may reduce or otherwise change the financial assurance in compliance with and to the extent permitted by such written approval and shall submit all documents evidencing such reduction or change to EPA pursuant to the delivery instructions in Paragraph 40 within 30 days after receipt of EPA's written decision. If EPA disapproves the request, Respondent may seek dispute resolution pursuant to Section XV (Dispute Resolution), provided however, that Respondent may reduce or otherwise change the financial assurance only in accordance with an agreement reached pursuant to Section XV or EPA's written decision resolving the dispute.

89. Respondent shall not release, cancel, or discontinue any financial assurance provided pursuant to this Section until: (a) Respondent receives written notice from EPA in accordance with Paragraph 94 that the Work has been fully and finally completed in accordance with this Settlement Agreement; or (b) EPA otherwise notifies Respondent in writing that it may release, cancel, or discontinue the financial assurance(s) provided pursuant to this Section. In the event of a dispute, Respondent may seek dispute resolution pursuant to Section XV (Dispute Resolution), and may release, cancel, or discontinue the financial assurance required hereunder only in accordance with an agreement reached pursuant to Section XV or EPA's written decision resolving the dispute.

XXVI. MODIFICATIONS

90. The OSC may make modifications to any plan, schedule, or Statement of Work in writing or by oral direction. Any oral modification will be memorialized in writing by EPA promptly, but shall have as its effective date the date of the OSC's oral direction. Any other requirements of this Settlement Agreement may be modified in writing by mutual agreement of the parties.

91. If Respondent seeks permission to deviate from any approved work plan, schedule, or Statement of Work, Respondent's Project Coordinator shall submit a written request to EPA for approval outlining the proposed modification and its basis. Respondent may not proceed with the requested deviation until receiving oral or written approval from the OSC pursuant to Paragraph 90.

92. No informal advice, guidance, suggestion, or comment by the OSC or other EPA representatives regarding reports, plans, specifications, schedules, or any other writing submitted by Respondent shall relieve Respondent of its obligation to obtain any formal approval required by this Settlement Agreement, or to comply with all requirements of this Settlement Agreement, unless it is formally modified.

XXVII. ADDITIONAL REMOVAL ACTION

93. If EPA determines that additional removal actions not included in the Removal Work Plan, or other approved plan are necessary to protect public health, welfare, or the environment, and such additional removal actions are consistent with Section VI (Settlement Agreement and Order), EPA will notify Respondent of that determination. Unless otherwise stated by EPA, within 30 days after receipt of notice from EPA that additional removal actions are necessary to protect public health, welfare, or the environment, Respondent shall submit for approval by EPA a work plan for the additional removal actions. The plan shall conform to the applicable requirements of Section VIII (Work to Be Performed) of this Settlement Agreement. Upon EPA's approval of the plan, Respondent shall implement the plan for additional removal actions in accordance with the provisions and schedule contained therein. This Section does not alter or diminish the OSC's authority to make oral modifications to any plan or schedule pursuant to Section XXVI (Modification).

XXVIII. NOTICE OF COMPLETION OF WORK

94. When EPA determines, after EPA's review of the Final Report, that all Work has been fully performed in accordance with this Settlement Agreement, with the exception of any continuing obligations required by this Settlement Agreement, EPA will provide written notice to Respondent. If EPA determines that any such Work has not been completed in accordance with this Settlement Agreement, EPA will notify Respondent, provide a list of the deficiencies, and require that Respondent modify the Work Plan if appropriate in order to correct such deficiencies. Respondent shall implement the modified and approved Work Plan and shall submit a modified Final Report in accordance with the EPA notice. Failure by Respondent to implement the approved modified Work Plan shall be a violation of this Settlement Agreement.

XXIX. INTEGRATION/APPENDICES

95. This Settlement Agreement and its appendices constitute the final, complete and exclusive agreement and understanding among the Parties with respect to the settlement embodied in this Settlement Agreement. The parties acknowledge that there are no

representations, agreements or understandings relating to the settlement other than those expressly contained in this Settlement Agreement. The following appendices are attached to and incorporated into this Settlement Agreement: Appendix A (Site Map), Appendix B (Action Memorandum), and Appendix C (Statement of Work).

XXX. EFFECTIVE DATE

96. This Settlement Agreement shall be effective on the day the Settlement Agreement is signed by the Regional Administrator or his delegate.

The undersigned representative of Respondent certifies that he is fully authorized to enter into the terms and conditions of this Settlement Agreement and to bind the party he represents to this document.

Agreed this 5TH day of February, 2015

for 

John Wolfe,
Chief Executive Officer
Port of Tacoma

It is so ORDERED and Agreed this 6 day of February, 2015

BY: 
Chris Field

DATE: 2/6/15

fn
Program Manager

Emergency Management Program
Region 10
U.S. Environmental Protection Agency

EFFECTIVE DATE: 2/6/15

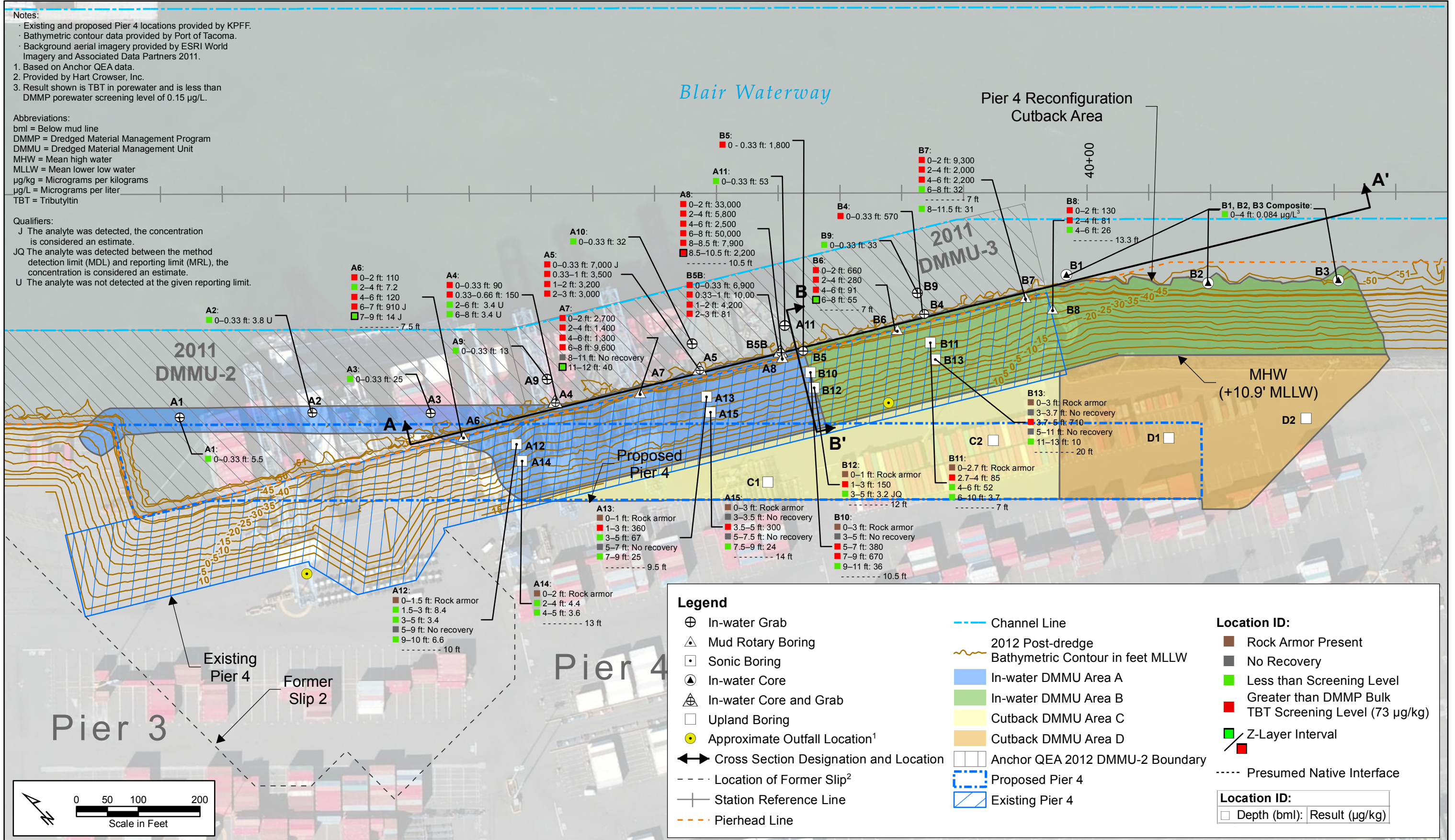

I:\GIS\Projects\POT_Pier_4\MXD\Task 3030\Characterization Report\Figure 4.1 (Sediment TBT Sampling Results).mxd 1/31/2014

APPENDIX B

**ACTION MEMORANDUM
FOR THE TIME CRITICAL REMOVAL ACTION
AT THE BLAIR WATERWAY TBT SITE
TACOMA, WA.**



**UNITED STATES ENVIRONMENTAL PROTECTION AGENCY
REGION 10**

1200 Sixth Avenue, Suite 900
Seattle, WA 98101-3140

JAN 27 2015

OFFICE OF
ENVIRONMENTAL CLEANUP

MEMORANDUM

SUBJECT: Action Memorandum for the Time-Critical Removal Action at the Blair Waterway TBT Site, Tacoma, Pierce County, Washington

FROM: Kathy Parker, On-Scene Coordinator
Emergency Preparedness and Prevention Unit
Emergency Management Program *Kathy Parker*

THRU: Wally Moon, Unit Manager *Wally Moon*
Emergency Preparedness and Prevention Unit

TO: Chris D. Field, Program Manager
Emergency Management Program

I. PURPOSE

The purpose of this Action Memorandum is to request and document approval of the time-critical removal action described herein for the Blair Waterway TBT Site located at the Port of Tacoma, Tacoma, Pierce County, Washington (Site).

The proposed removal action is expected to be performed by the Port of Tacoma (Port), a potentially responsible party (PRP) in accordance with the Comprehensive Environmental Response, Compensation, and Liability Act (CERCLA) with oversight by the U.S. Environmental Protection Agency (EPA).

II. SITE CONDITIONS AND BACKGROUND

The CERCLIS ID Number is WAD980726368 and the Site ID Number is 10MY.

A. Site Description

1. Removal Site Evaluation

The Port is in the process of upgrading its existing infrastructure to allow larger vessels to dock at the Port. This effort includes aligning the Terminal 4 Pier (Pier 4) with the adjacent Terminal 3. As described below, the discovery of tributyltin (TBT) within the footprint of the proposed project triggered the removal action.

As part of the upgrade, the Port conducted multiple soil and sediment sampling events in 2013 under the Dredged Material Management Program (DMMP). The DMMP is an interagency collaborative which includes sediment specialists, biologists, chemists and other environmental experts from U.S. Army

Corps of Engineers Seattle District (USACE), EPA, Washington Department of Ecology (Ecology), and Washington Department of Natural Resources (DNR). The DMMP requires characterization of the dredged material for open water disposal or beneficial habitat reuse.

April 2013 DMMP Characterization Sampling

TBT was first used in antifouling paints in the 1950s to coat vessels and marine structures to prevent marine organisms from attaching to the painted surface. From April through November 2013, Port sampling below and near Pier 4 showed TBT in sediments at concentrations exceeding the DMMP screening level (SL) of 73 micrograms per kilogram ($\mu\text{g}/\text{kg}$). No other chemicals of concern were detected at concentrations exceeding the DMMP SLs. TBT was identified laterally along the pier face, at concentrations exceeding the DMMP SL of 73 $\mu\text{g}/\text{kg}$, down to a maximum depth of 10.5 feet below mudline (bml). The sample in the central portion of the dredge prism had both the deepest contamination and the highest detected concentration of TBT at 50,000 $\mu\text{g}/\text{kg}$. In general, TBT concentrations exceeding the DMMP SL were detected in samples collected from all pier face borings.

The source of TBT is unknown at this time. No indications of TBT-related contamination or paint chips were observed during the pier face or under-pier sample collection events, or during microscopic analysis of sediment samples collected from the area of highest detected TBT concentrations. Additionally, no other indications of contamination such as sheen or odor were observed during sample collection events. The TBT-contaminated sediment found underneath this portion of Pier 4 was possibly transported downslope to the pier face during the most recent maintenance dredging of the Pier 4 berthing area, which was completed in 2012. During this event, the contractor dredged accumulated sediments in the berthing area to a final target depth of -51 feet Mean-Low-Low-Water (MLLW). Accumulated sediments on the lower portion of the armored slope, underneath the pier, were also pulled water-ward from the slope into the dredge prism to minimize post-maintenance dredging sloughing. The rock keyway, an approximately 10-foot-wide by 5-foot-deep section of riprap located at the toe of the slope, was not dredged extensively during this event in an effort to preserve slope stability.

The 2013 sediment grab and core sample locations directly in front of the pier were possibly within the keyway and the inability to core deeper during sampling was due to both the keyway rock and potential movement of the slope armoring associated with the 2012 dredge event. It is presumed that residual historical sediment left in this area and additional sloughing of historical contaminated sediments from the lower portion of the under-pier slopes are the source of the elevated sediment TBT concentrations at the pier face.

July 2014 Removal Site Evaluation

The Port entered into an Administrative Order on Consent (AOC 1) with EPA in June 2014. That AOC required the Port to perform a Removal Site Evaluation (RSE), which included additional soil, sediment, and ambient site water sampling.

Sampling conducted in July 2014 vertically delineated the extent of TBT-contaminated sediments at the pier face (Sample Locations A16 and A17), and horizontally delineated the extent of TBT-contaminated sediments to the south end of Pier 4, with TBT detected at concentrations less than the DMMP SL or non-detect in samples collected from directly south of the pier at Sampling Locations B16, B17, and B-18A (Figure 2.1).

Because visual indications of TBT, such as paint chips, were not observed during previous sampling

events, the site sediment sample with the highest TBT concentration detected during the July 2014 sampling event (A16) was analyzed by stereomicroscopy and scanning electron microscopy (SEM) with energy dispersive X-ray spectrometry (EDS) to evaluate the presence and distribution of TBT in the samples. SEM/EDS analysis was performed on the 0 to 4 foot bml composite sample collected from A16, which had a detected TBT concentration of 42,000 µg/kg. Visual analysis with an SEM did not detect the presence of paint chips, but tin was identified at percentages by weight ranging from approximately 0.2 to 0.4 percent. EDS analysis of the samples found that tin was associated with very fine silicate particles, which are presumed to be clays. Based on this information, the TBT is not believed to be in the form of paint chips, such as would be expected from hull cleaning debris.

In order to assess contaminant concentrations in the water column from sediment resuspension at the point of dredging, site sediment samples and one site ambient water sample were collected during the July 2014 sampling event to be used for potential Dredging Residual Elutriate Tests (DRETs). The DRETs were conducted to gain information regarding potential water quality during the removal of the TBT-contaminated material under the USEPA removal process. The DRETs were conducted in accordance with USACE-recommended procedures and modified per prior consultation with Analytical Resources, Inc. (ARI) and the DMMP agencies through email and telephone conversations.

Results from DRETs help determine whether sediment chemical contaminants are likely to be found at concentrations of concern in the water column relative to the acute and chronic water quality criteria. Marine TBT water quality criteria are present as µg/L dissolved TBT with the acute criterion at 0.42 µg/L and the standard chronic criterion at 0.0074 µg/L. The acute water quality criterion is typically applied at the project point of compliance, anticipated to be 150 feet from the point of dredge operations at Pier 4.

Three samples were submitted for DRET analysis, including the 0 to 4 feet bml composite collected from A16 and the 0 to 8 feet bml composite and field duplicate collected from A17. Bulk TBT concentrations in these samples ranged from 340 to 42,000 µg/kg and were selected to represent the likely range of TBT concentrations present in contaminated sediments within the dredge prism. The dissolved TBT concentrations resulting from DRET analysis ranged from 0.16 to 0.39 µg/L and were all less than the acute water quality criterion of 0.42 µg/L.

2. Physical Location

The Site is located on Port of Tacoma property¹. The area to be dredged is at Pier 4 near Husky Terminal on the west side of the northern portion of the Blair Waterway, adjacent to Commencement Bay and approximately 400 yards north of the Port of Tacoma Road, Tacoma, Washington. The precise location is 47.27345 North Latitude; 122.40791 West Longitude. The Pier 4 project area is zoned for port maritime and industrial use. It is bounded to the south by the Fairliner mitigation area, Concrete Technology Corporation, and Washington United Terminal, and is across the waterway from Totem Ocean Trailer Express. The project-related transload site, where dredged material will be dewatered and the water treated, will be at APM terminals on the Sitcum Waterway. The two terminals are contiguous and connected by Sitcum Way, also owned by the Port of Tacoma.

3. Site characteristics

¹ To clarify, the Port of Tacoma owns all pier structures and has management authority over the state-owned aquatic land beneath them.

The Site is an active shipping terminal on the west side of the northern portion of the Blair Waterway. The Site was originally part of the Puyallup River delta, which spread northwest into Commencement Bay. Prior to filling and construction of the current Port, the area within the shoreline cutback was tidal flats with an approximate elevation of +10 MLLW. The waterway (originally called the Wapato Waterway) was constructed from Commencement Bay to East 11th Street by local interests in the 1920s, 1930s, and 1940s by the dredging of intertidal and shallow subtidal lands and filling adjacent lands to construct uplands.

Renamed the Blair Waterway in 1969 after reaching its current configuration, the waterway is approximately 2.6 miles long. Several dredging projects undertaken since 1969 have deepened the navigation channel to -51 feet MLLW and the channel width in the vicinity of the Pier 4 project site is 343 feet. Since its creation, the Blair Waterway has been operated, managed, and maintained as an industrial and commercial navigable waterway.

The Site consists of a vessel berthing area with an average water depth of 45 to 63 feet, with tidal fluctuations of up to 14 feet. The pier is constructed over a 2:1 riprap rock armored slope with approximately 2 feet of armor, and is composed of precast concrete deck panels, multiple inches of rock ballast, and multiple inches of surface asphalt covering a pile-supported deck that supports container cranes. The adjacent asphalt paved uplands areas are used for container storage and truck travel lanes. Pier 4 most recently underwent maintenance dredging of the berth area in 2011.

4. Release or threatened release into the environment of a hazardous substance, or pollutant or contaminant

The contaminant of concern at the Site is tributyltin (TBT). TBT is a hazardous substance, as defined by §101(14) of CERCLA, as amended, 42 U.S.C. §9601(14) and 40 CFR §302.4. Other hazardous substances may also be on-Site but have not been identified.

TBT was an ingredient in antifouling paint used to coat vessels and marine structures to prevent marine organisms from attaching to the painted surface. Adverse ecological effects associated with TBT antifouling paints resulted in it being prohibited for use in the United States and eventually an international treaty was signed in 2008 to prohibit the use of TBT in hull coatings. The source of the TBT at the site is unknown at this time.

An estimated 47,000 CY of TBT-contaminated sediments varying in concentration from 2 to 50,000 ug/kg are believed to be present within the footprint of the Pier 4 project. Because TBT is partially soluble in water, it is currently releasing into the water column. Water movement due to marine vehicle traffic and tidal changes and currents can also move the sediment particles away from their current location.

5. NPL Status

The Site is not listed on the National Priority List (NPL) nor will it be referred to Site Assessment for further evaluation.

The Site is located within the Commencement Bay-Nearshore Tidelands (CB-NT) Superfund Site, however the Site is not included in the CB-NT Record of Decision (ROD) because at the time the ROD was completed, sediment samples collected from the Blair Waterway did not exceed cleanup standards.

6. Maps, pictures, and other graphic representations

Figure 2.1 - Vicinity map

Figure 2.2 - Site map

Figure 4.1 - TBT data summary figure

Figure A.2 - Dredge area figure showing the known extents of TBT contamination

B. Other Actions to Date

1. Previous Actions

There have been no government or private actions undertaken in the past under the authority of CERCLA or the Clean Water Act other than those discussed above in *Section II. Site Conditions and Background*.

2. Current actions

There are no government or private cleanup activities that are currently being performed at the Site.

C. State and Local Authorities' Roles

1. State and local actions to date

As part of the DMMP, the State of Washington has been actively involved with the characterization of TBT-contaminated sediments at this Site and with development of the proposed removal action for cleanup of the Site.

2. Potential for continued State/local response

The DMMP will continue to provide input and review documents submitted before and during the removal action.

D. Government-to-government consultation with the Puyallup Tribe

Staff-to-staff level coordination has occurred between EPA and employees of the Puyallup Tribe of Indians regarding the characterization of TBT-contaminated sediments and with development of the proposed removal action for the Site. Formal consultation has offered to the Tribe in a letter dated November 19, 2014.

E. Terminal 4 Pier Modernization Project

The Port of Tacoma is pursuing funding under the U.S. Department of Transportation's Fiscal Year 2014 Transportation Investment Generating Economic Recovery (TIGER) Discretionary Grants program for the Port's Pier 4 Modernization Project. Pier 4, built more than 40 years ago, cannot support the loads imposed by larger cranes and equipment necessary to serve larger vessels. This time-critical removal action will support the Port's Terminal Pier 4 modernization project by removing TBT-contaminated-sediments from the footprint of the project.

III. THREATS TO PUBLIC HEALTH OR WELFARE OR THE ENVIRONMENT, AND STATUTORY AND REGULATORY AUTHORITIES

The current conditions at this Site meet the following factors which indicate that the Site is a threat to the public health or welfare or the environment, and a removal action is appropriate under the National Oil and Hazardous Substances Pollution Contingency Plan (NCP), 40 C.F.R. 300.415(b)(2).

1. **Actual or potential exposure to nearby human populations, animals, or the food chain from hazardous substances or pollutants or contaminants (300.415[b][2][i]).**

Human Health Effects

TBT compounds are moderately toxic to humans via both ingestion and dermal absorption exposure pathways. However, these exposure pathways are not considered complete because the TBT-contaminated sediments are overlain by several feet of seawater.

Environmental Effects

TBT-contaminated sediments have been detected at concentrations exceeding the DMMP SL of 73 µg/kg along the pier face and on the slope underlying the pier. The greatest detected concentration of TBT on-site is 50,000 µg/kg. TBT was not detected in an ambient site water sample collected from approximately 6 feet above the mudline in the pier face TBT hot spot, using a low level analysis method with a reporting limit of 0.005 µg/L.

TBT is associated with a number of adverse health effects on marine life including severe reduction in the population of benthic invertebrates, deformation of shells in oysters, and masculinization of female marine snails (imposex). In marine mammals, TBT is associated with developmental defects, obesity, immunosuppression, hearing loss, and premature death.

Ecological receptors can become exposed to the Site contaminant through direct contact with TBT and sediments contaminated by TBT; ingestion of TBT and with sediments contaminated by TBT; and through the food chain by consuming animals and plants that have accumulated TBT.

2. **The availability of other appropriate federal or state response mechanisms to respond to the release (300.415[b][2][vii]).**

The proposed time-critical removal action is expected to be conducted by the Port in accordance with CERCLA and with oversight by EPA. At this point, there are no known other appropriate federal or state response mechanisms capable of providing the appropriate resources in the prompt manner needed to address the ecological risks associated with the hazardous substance described herein.

IV. ENDANGERMENT DETERMINATION

Actual or threatened releases of hazardous substances from this Site may present an imminent and substantial endangerment to public health, or welfare, or the environment.

V. PROPOSED ACTIONS AND ESTIMATED COSTS

A. Proposed Action

1. Proposed Action Description

The removal action includes demolition of the majority of the Pier 4 structure to allow for access equipment to remove the underlying material, and the dredging of approximately 47,000 CY of TBT-contaminated sediments, as well as approximately 11,000 CY of clean sediments.

The scope of this removal action is limited to the tasks necessary to facilitate the removal of the TBT-contaminated sediments, waterway navigation safety, and testing for reinstallation of pilings. Demolition of the remaining Pier 4 structure, including additional pile removal, and pier reconfiguration, will be conducted after the completion of the Removal Action. This work is described in the Removal Action Work Plan (RAWP) being developed by the Port in coordination with the EPA.

The Removal Action (conducted as Phase 1 of the overall Pier Reconfiguration Project) includes the following tasks:

- Mobilization and staging of equipment.
- Demolition of the majority of the existing Pier 4 structure, approximately 140,550 square feet (approximately 133,780 square feet waterward of ordinary high water mark [OHWM²], including the existing bulkhead).
- Vibratory removal of approximately 1,047 16.5-inch-diameter concrete piles.
- Vibratory removal of approximately 87 14-inch-diameter creosote treated timber piles and 22 20-inch-diameter steel pipe piles associated with an existing pile-supported fender system.
- Concrete test pile program for site restoration.
- Removal and relocation of the existing navigation light on the south end of the pier as well as its companion navigation light located on the other side of the Blair Waterway. This will include the removal of four 18-inch-diameter existing steel piles (which support the companion navigation light) located on the other side of the waterway, and the installation of a total of eight 18-inch-diameter steel piles for the replacement navigation lights. Removal and relocation of navigation lights will be done in coordination with the U.S. Coast Guard and the Puget Sound Pilots.
- Dredging of approximately 47,000 CY of TBT-contaminated sediments and approximately 11,000 CY of clean sediments. The planned extents of dredging are presented in the detail in the RAWP.

² The OHWM, as defined in the Shoreline Management Act, is a biological vegetation mark. Ecology's guidance states that in high energy environments where the action of waves or currents is sufficient to prevent vegetation establishment below mean higher high tide, the OHWM mark is coincident with the line of vegetation. Where there is no vegetative cover for less than 100 feet parallel to the shoreline, the OHWM is the average tidal elevation of the adjacent lines of vegetation. Where the OHWM cannot be found, it is the elevation of mean higher high tide (WAC 173-22-030 [5][a]). In order to determine the OHWM (or lack thereof) at the project site, in July 2014 a field inspection was conducted to identify the relevant physical and biological indicators of OHWM present in the Pier 4 project area along the Blair Waterway. The results of the field determination indicated that +12.78 feet MLLW represents a conservative estimate of OHWM that is supported by surrounding biological and physical indicators (Confluence 2014b).

- Management and treatment of contaminated dredge material return water.
- Transloading and upland disposal of dredge material.
- Chemical monitoring, confirmational sampling and surveying, both inside and outside of the dredge prism.

With the exception of a few remote utility modifications and disconnects (electrical and water systems), all project activities will be conducted either below and waterward of the project-specific OHWM of the Blair Waterway, or within 50 feet of the OHWM within the marine shoreline buffer as designated by the City of Tacoma Municipal Code (TMC) Section 13.10.6.4.3 (B)(3).

Construction Sequence and Work Elements

Work will be sequenced for construction efficiency and to restrict the removal of the TBT-contaminated sediments (dredging) to the in-water work window, with additional timing recommendations/restrictions from the Washington State Department of Fish and Wildlife (WDFW). At WDFW's request, the Port will wait until August 1, 2015 to start dredging the TBT-contaminated sediments, rather than at the start of the allowable in-water work window of July 16, 2015, to further reduce potential impacts to the tail end of the out-migrating juvenile salmonids.

Prior to dredging the contaminated sediments in the first week of August, the Port will remove the clean sediments located on the top of the slope (above the TBT-contaminated sediments) after the start of the in-water work window on July 16, 2015, consistent with the following timeline. The timeline shows the current estimated start and the approximate number of calendar days for each project element, without considering construction sequencing:

- Mobilization and Staging: late March 2015; 30 days
- Demolition of the majority of the existing Pier 4 structure (deck demolition, including bulkhead and utilities): early May; 100 days
- Vibratory extraction of piles (concrete, creosote-treated timber, and steel): mid-June 2015; 100 days
- Clean riprap removal and disposal: early September; 21 days
- Removal and relocation of the existing navigation light: mid-July 2015; 75 days
- Dredging of clean top of slope material: mid-September; 14 days
- Dredging of TBT-contaminated sediments: mid-October, 2015; 109 days
- Concrete test pile program for site restoration: late-December to mid-January; 12 days
- Demobilization: mid-February 2016; 30 days

The management and treatment of dredge water, as well as transloading and upland disposal of dredge material, will occur throughout the duration of dredging. The site demolition and in-water

work is anticipated to be completed by mid-February 2016. Off-site dewatering and treatment may extend beyond this anticipated completion.

Best-Management Practices (BMPs)

Appropriate construction and conservation measures (or BMPs) will be implemented during cleanup activities, including: in-water work; water treatment; and transloading, to protect workers and nearby terminal operations from short-term construction impacts. These include erosion and sedimentation, fugitive dust, and other similar impacts. Additionally, in-water work will occur only during certain periods to ensure that adverse effects to the aquatic environment are minimal.

Non-hazardous wastes such as inert construction debris will be reused, disposed of, or recycled in accordance with appropriate solid waste disposal or recycling requirements.

Greener Cleanup Best Management Practices

Appropriate greener cleanup BMPs will be implemented during cleanup activities, including, but not limited to: minimizing energy consumption; minimizing generation and transport of fugitive dust; minimizing waste generation through reuse and recycling, minimizing impacts to water resources; minimizing areas requiring activity or use limitations, minimizing unnecessary habitat disturbance; and minimizing lighting and noise disturbance.

Assessment and characterization of known and suspected hazardous wastes and potentially contaminated soils

TBT and turbidity will be monitored during piling removal and dredging. The analytical results will be used to adjust construction practices to prevent migration of contaminated sediments off-Site. During dredging, sediments in the contaminant footprint will be analyzed for TBT to determine when the action level has been achieved. After dredging, the remaining sediments will be analyzed for TBT to determine the residual TBT concentrations remaining on-Site.

The waste sediments and wastewater from dredging will be analyzed for TBT prior to disposal. The Post-Dredge Confirmational Sampling Plan and the Water Quality Monitoring and Protection Plan are appended to the RAWP.

Excavation and disposal of dredged material

TBT-contaminated sediments will be dredged onto barges, transferred to land for dewatering and solidification, loaded onto trucks and moved to a non-hazardous waste disposal facility (e.g. LRI in Graham, Washington). Water collected from dredged sediments will be treated to remove TBT and particulates, and then discharged to surface water. Sediments dredged from the areas determined in advance to be below actionable concentrations will be disposed of by in-water disposal at a nearby ecological re-use site.

Post removal site controls

Post-removal site controls (PRSCs) are not expected to be required because residual TBT contamination exceeding cleanup levels will not be left in place. However, if PRSCs such as signage or fencing are required, these activities will be managed by the Port.

2. Contribution to remedial performance

No further EPA actions are expected for the Site because actionable concentrations of TBT-contaminated sediments will not remain on-Site. However, if additional action is required, this removal action will not impede future responses based on available information.

3. Engineering Evaluation/Cost Analysis (EE/CA)

Because this proposed action is for a time-critical removal action, an EE/CA is not required.

4. Applicable or relevant and appropriate requirements (ARARs)

The following section presents the chemical-, action- and location-specific ARARs for the Blair Waterway TBT Site and describes how the Removal Action will fulfill these ARARs.

Chemical-Specific ARARs

Clean Water Act Ambient Water Quality Criteria [33 USC 1251 Section 304(a)]; Washington Surface Water Quality Standards [RCW 90-48; WAC 173-201A]. The proposed action will protect surface water quality by minimizing the potential release of TBT to the Blair Waterway. To protect water quality, the work area will be surrounded by an absorbent boom and dredging within the hot spot areas will include the use of a floating boom-supported curtain. Surface water quality monitoring will be conducted during project activities, including the discharge of dredge return water, to ensure compliance with applicable standards per the Water Quality Monitoring and Protection Plan provided in the RAWP.

Action-Specific ARARs

Resource Conservation and Recovery Act [42 USC 6901], Subtitle D - Managing Municipal and Solid Waste [40 CFR Parts 257 and 258]. Waste material (dredged sediment, extracted piles, bulkhead materials, anthropogenic debris) removed from the Site will be managed using an appropriately permitted, off-site disposal facility.

Clean Water Act--Discharge of Dredge Material into Navigable Waters [33 USC 401 et seq.; 33 USC 141; 33 USC 1251- 1316; 40 CFR 230, 231, 404; 33 CFR 320-330]; Rivers and Harbors Act [33 USC 401 et seq.]; Washington Hydraulic Code Rules [RCW 75.20; WAC 220-110].

The proposed action includes dredging, waste material removal, and potentially backfill placement within the site. EPA has consulted with local, state, and federal agencies. Project work practices and BMPs address ARAR substantive requirements, including the use of clean backfill materials,

minimizing water quality and fisheries impacts by using appropriate equipment, hot spot dredging within a floating boom supported curtain, implementing numerous project BMPs, and conducting the TBT-contaminated dredging within the Commencement Bay allowable in-water work window to avoid potential impacts to fisheries resources. Specific BMPs to prevent discharge of dredge materials into navigable waters are described in detail in the RAWP.

Clean Water Act—Obstruction of Navigation and Navigable Waters [33 USC 401 et seq.]; Rivers and Harbors Act [33 USC 401 Section 10]; USACE Navigation and Navigable Waters [40 CFR 320-322]. The Clean Water Act prohibits unauthorized activities that obstruct or alter a navigable waterway. Section 10 applies to all structures or work below the mean high water mark of navigable tidal waters and the ordinary high water mark of navigable fresh waters. USACE permits are needed for the alteration or the modification of the course, condition, location, or capacity of a navigable water of the United States. The removal action will not be conducted within the navigation channel. Therefore, no alteration of the navigation channel elevations will occur as part of this remedial action.

Migratory Bird Treaty Act (MBTA). 16 USC § 703 et seq. Makes it unlawful to “hunt, take, capture, kill” or take various other actions adversely affecting a broad range of migratory birds, including tundra swans, hawks, falcons, songbirds, without prior approval by the U.S. Fish and Wildlife Service. (See 50 CFR 10.13 for the list of birds protected under the MBTA.) Under the MBTA, permits may be issued for take (e.g., for research) or killing of migratory birds (e.g., hunting licenses). The mortality of migratory birds due to ingestion of contaminated sediment is not a permitted take under the MBTA. The Act is applicable for protecting migratory bird species identified. The selected removal action is to be carried out in a manner that avoids the taking or killing of protected migratory bird species, including individual birds or their nests or eggs.

Archaeological Resources Protection Act 16 USC § 470.aa et seq.; 43 CFR Part 7. Prohibits the unauthorized disturbance of archaeological resources on public or Indian lands. Archaeological resources are “any material remains of past human life and activities which are of archaeological interest,” including pottery, baskets, tools, and human skeletal remains. The unauthorized removal of archaeological resources from public or Indian lands is prohibited without a permit, and any archaeological investigations at a site must be conducted by a professional archeologist. The Act is applicable for the conduct of any selected response actions that may result in ground disturbance.

Location-Specific ARARs

Endangered Species Act [16 USC 1531 et seq.; 50 CFR Parts 200, 402]; Magnuson-Stevens Fishery Conservation and Management Act [16 USC 1801-1884]. EPA has consulted with the U.S. Fish and Wildlife Service and with the National Marine Fisheries Service. The proposed action incorporates measures to prevent potential impacts to endangered and threatened species including Chinook salmon during construction. Specific BMPs to protect endangered and threatened species during in-water work and measures to minimize elevated underwater noise and protect water quality are described in detail in the RAWP. NMFS agrees that following the BMPs and timing will substantially avoid potential adverse effects on ESA-listed fishes and marine mammals.

Migratory Bird Treaty Act [16 USC 1801-1884]. The proposed action is consistent with regulations regarding habitat for fish, plants or birds because it will minimize potential risks to fish and wildlife habitat from potential releases of contaminated materials. Specific BMPs for preventing habitat impacts, including conducting TBT-contaminated sediment dredging within the Commencement Bay allowable in-water work window, are described in detail in the RAWP.

National Emission Standards for Hazardous Air Pollutants (NESHAP), 40 CFR 61, Subpart M. Subpart M addresses milling, manufacturing, and fabricating operations, demolition and renovation activities, waste disposal issues, active and inactive waste disposal sites, and asbestos conversion processes. Subpart M is potentially applicable to the handling, packaging, labeling, transportation, and disposal of asbestos-containing material.

National Historic Preservation Act [16 USC § 470.f; 36 CFR Parts 60, 63, 800]. The National Historic Preservation Act (NHPA) requires federal agencies to consider the possible effects on historic sites or structures of any undertaking proposed for federal funding or approval. Historic sites or structures are those included on or eligible for the National Register of Historic Places (NRHP), generally older than 50 years. If an agency finds a potential adverse effect on historic sites or structures, such agency must evaluate alternatives to “avoid, minimize, or mitigate” the impact, in consultation with the Advisory Council on Historic Preservation (ACHP). The NHPA is potentially applicable to response actions such as demolition of old mine or mill structures on the Site. In consultation with the ACHP unavoidable impacts on historic sites or structures may be mitigated through such means as taking photographs and collecting historic records. Under the NHPA implementing regulations, consultation with the ACHP may effectively be accomplished through contact with the State Historic Preservation Officer and possibly other interested parties.

5. Project Schedule

It is expected that project implementation will begin in March 2015 and will take approximately eleven months to complete.

B. Estimated Costs

EPA and the Port are currently negotiating a second AOC (AOC 2). Both AOC 1 and AOC 2 require the Port to pay for the cost of the removal action, including EPA’s oversight costs. If EPA were to undertake implementation of the work described in this Action Memorandum, an amendment to this Action Memorandum will be written.

VI. EXPECTED CHANGE IN THE SITUATION SHOULD ACTION BE DELAYED OR NOT TAKEN

If the proposed Removal Action should be delayed or not taken, hazardous substances will remain as potential human health and ecological threats and hazardous substances will remain a continuing source of solid and dissolved-phase contaminants.

VII. OUTSTANDING POLICY ISSUES – None

VIII. ENFORCEMENT

See confidential enforcement addendum.

IX. RECOMMENDATION

This decision document sets forth the recommended removal action for the Blair Waterway TBT Site, Tacoma, Pierce County, Washington that has been developed in accordance with CERCLA as amended, and is consistent with the NCP. The recommended removal action is based on the administrative record for the Site.

Conditions at the Site meet the NCP's (40 CFR Section 300.415(b) (2)) criteria for a removal action and I request your approval of the recommended removal action.

X. APPROVAL / DISAPPROVAL

By the approval which appears below, EPA selects the removal action for the Site as set forth in the recommendations contained in this Action Memorandum.

APPROVAL:



Ar _____
Chris D. Field, Manager
Emergency Management Program

January, 27, 2015

Date

DISAPPROVAL:

Chris D. Field, Manager
Emergency Management Program

Date

Note:
Orthoimagery provided by Esri, 2013.





Notes:
 · Pier 4 location based on KPFF data.
 · Background aerial imagery provided by Esri, August 1, 2011.



FLOYD | SNIDER
 strategy ■ science ■ engineering

**Removal Site Evaluation Report
 Pier 4 Phase 1 Removal Action Project
 Tacoma, Washington**

Figure 2.2
 Site Location Map of Pier 4

- Notes:
- All field locations are actual locations as measured on-site during the sampling events.
 - Results from April 2013 Geoprobe sampling did not exceed the DMMP TBT screening level and are not shown on this figure.
 - Existing and proposed Pier 4 locations provided by KPFF.
 - Bathymetric contour data provided by Port of Tacoma.
 - Background aerial imagery provided by Esri, 2011.
- Based on Anchor QEA data.
 - Provided by Hart Crowser, Inc.
 - Result shown is TBT in porewater and is less than DMMP porewater screening level of 0.15 µg/L.
 - Result shown is dissolved TBT from DRET test and concentration is greater than USEPA chronic marine aquatic life water quality criterion of 0.0074 µg/L but less than USEPA acute marine aquatic life water quality criterion of 0.42 µg/L.
 - Result shown is TBT in water and is less than USEPA chronic marine aquatic life water quality criterion of 0.0074 µg/L.

Abbreviations:

bml = Below mudline
 DMMP = Dredged Material Management Program
 DMMU = Dredged Material Management Unit
 DRET = Dredging Elutriate Test
 ft = Feet
 MLLW = Mean lower low water
 µg/kg = Micrograms per kilograms
 µg/L = Micrograms per liter
 OHWM = Ordinary high water mark
 TBT = Tributyltin
 USEPA = U.S. Environmental Protection Agency

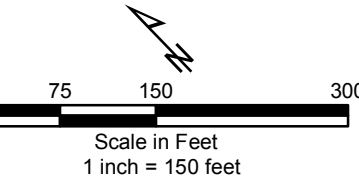
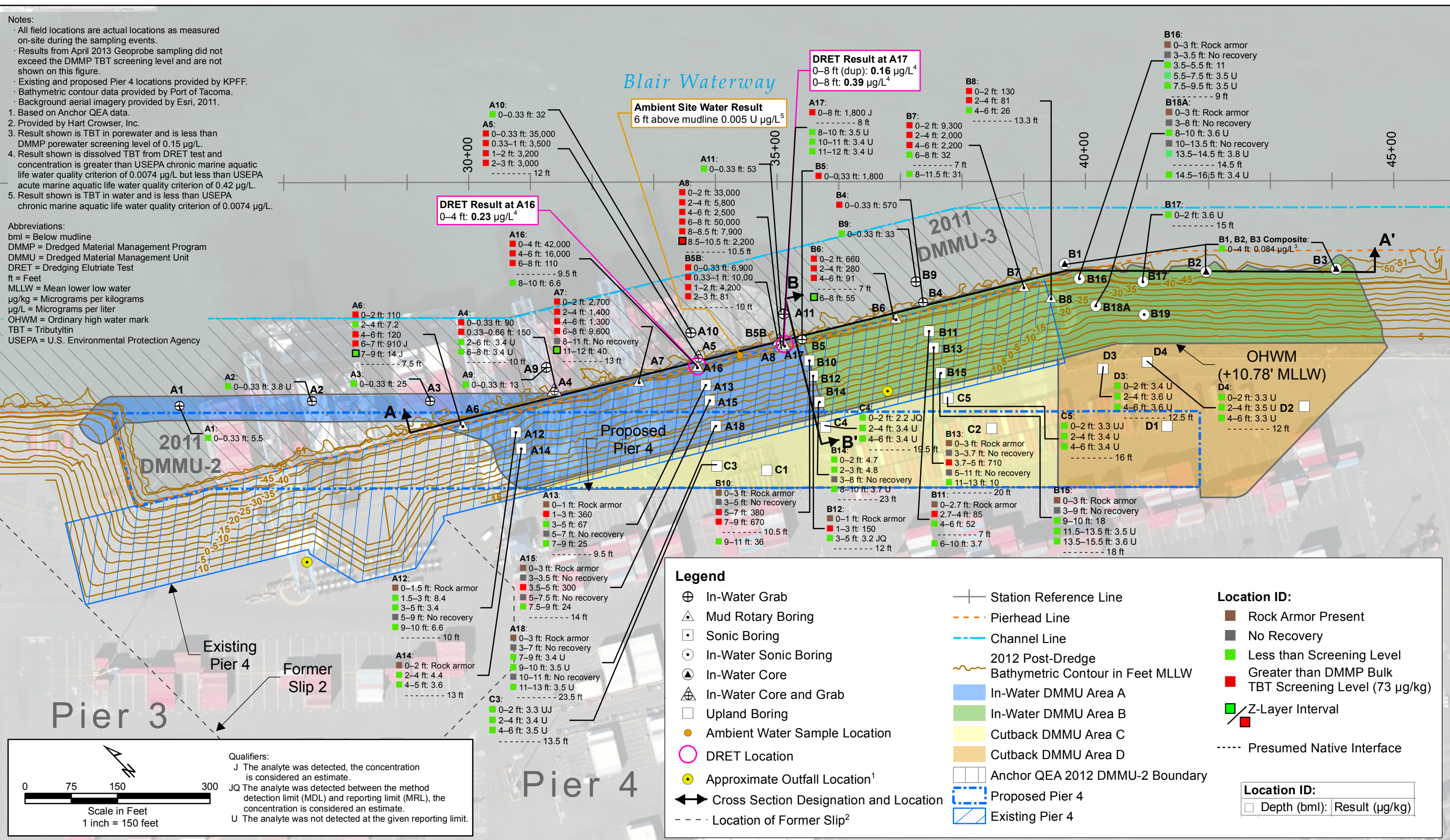

Qualifiers:

J The analyte was detected, the concentration is considered an estimate.
 JQ The analyte was detected between the method detection limit (MDL) and reporting limit (MRL), the concentration is considered an estimate.
 U The analyte was not detected at the given reporting limit.



Removal Site Evaluation Report
Pier 4 Phase 1 Removal Action Project
 Tacoma, Washington

Figure 4.1
 Pier 4 Sediment, Soil, Ambient Site Water, and DRET Sample Results

Notes:
 1. Dredge cut thicknesses shown do not include over-dredge allowance.
 2. Provided by Hart Crowser, Inc.
 * Indicates a DMMU composite sample result. Result shown for the Sample Location B1, B2, and B3 composite is a TBT concentration in porewater (in $\mu\text{g/L}$) and is less than the DMMP porewater screening level of $0.15 \mu\text{g/L}$.
 - All field locations are actual locations as measured on-site during the sampling events.
 - Existing and proposed Pier 4 locations provided by KPFF.
 - Bathymetric contour data provided by Port of Tacoma.
 - Background aerial imagery provided by Esri, 2011.

Abbreviations:
 bgs = Below ground surface
 bml = Below mudline
 DMMP = Dredged Material Management Program
 DMMU = Dredged Material Management Unit
 ft = Feet
 MLLW = Mean lower low water
 $\mu\text{g/kg}$ = Micrograms per kilograms
 $\mu\text{g/L}$ = Micrograms per liter
 OHWM = Ordinary High Water Mark
 TBT = Tributyltin

Blair Waterway

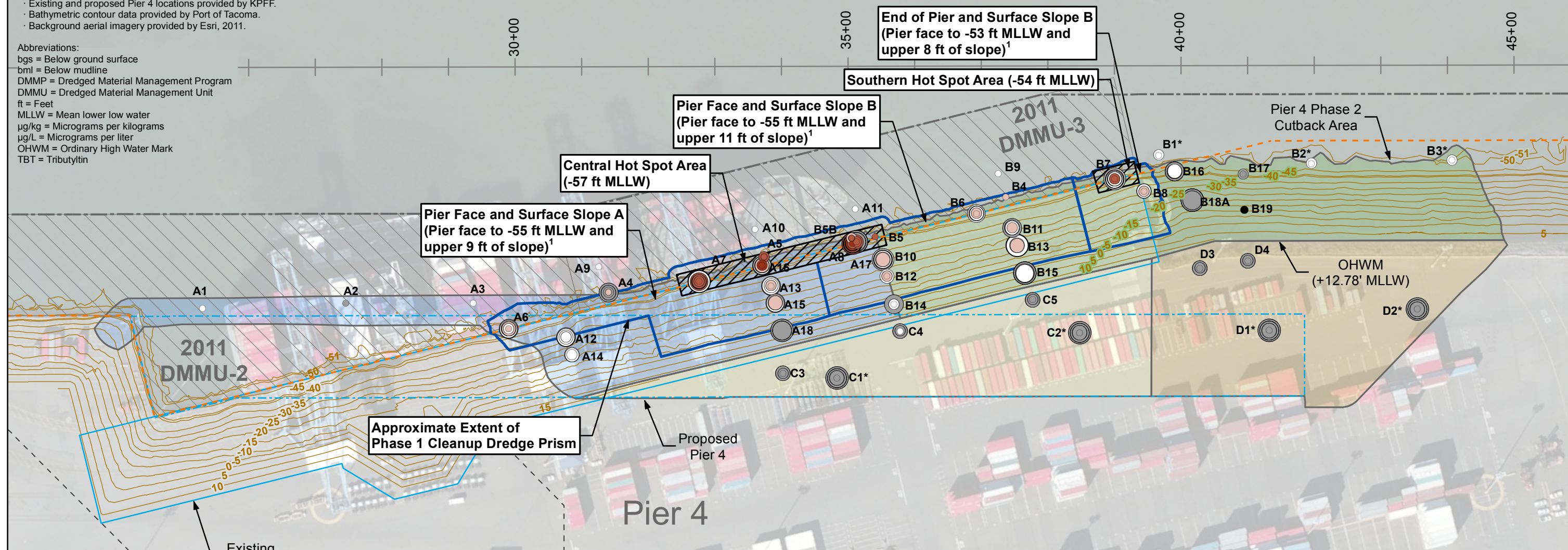

Legend

<p>TBT Concentration ($\mu\text{g/kg}$)</p> <ul style="list-style-type: none"> 0-73 74-1,000 1,001-1,300 1,301-10,000 10,001-50,000 Analyte was not Detected at the Given Reporting Limit No Data (sample not analyzed) 	<p>Sample Depth (bml or bgs)</p> <ul style="list-style-type: none"> ≤ 2 ft (surface sample) 2-4 ft 4-6 ft 6-10 ft > 10 ft 	<ul style="list-style-type: none"> Location of Former Slip² Station Reference Line Pierhead Line Channel Line 2012 Post-Dredge Bathymetric Contour in Feet MLLW 	<ul style="list-style-type: none"> In-Water DMMU Area A In-Water DMMU Area B Cutback DMMU Area C Cutback DMMU Area D Anchor QEA 2012 DMMU-2 Boundary Proposed Pier 4 Existing Pier 4
---	--	--	--

APPENDIX C

**STATEMENT OF WORK FOR THE
BLAIR WATERWAY TBT SITE
REMOVAL SITE EVALUATION**

TACOMA, WA

Table of Contents

GLOSSARY.....	2
1.0 INTRODUCTION.....	4
1.1 General	4
1.2 Oversight.....	4
1.3 Schedule.....	4
1.4 Guidance	4
2.0 TIME CRITICAL REMOVAL ACTION.....	5
2.1 General	5
2.2 Oversight and Guidance	5
2.3 Removal Action	5
3.0 COMMUNITY RELATIONS.....	7
4.0 SCHEDULE.....	6
5.0 ELECTRONIC DATA SUBMITTAL	6
6.0 REFERENCES.....	8
6.1 References Cited in Document	8

GLOSSARY

ARAR	Applicable or Relevant and Appropriate Requirement
BA	Biological Assessment
CERCLA	Comprehensive Environmental Response, Compensation and Liability Act
CFR	Code of Federal Regulations
COC	Contaminant of Concern
COI	Contaminant of Interest
CSM	Conceptual Site Model
CWA	Clean Water Act
Ecology	State of Washington Department of Ecology
DQO	Data Quality Objective
FSP	Field Sampling Plan
GIS	Geographic Information System
HASP	Health and Safety Plan
IC	Institutional Control
NCP	National Contingency Plan
OSHA	Occupational Safety and Health Administration
OSWER	Office of Solid Waste and Emergency Response
QA	Quality Assurance
QAPP	Quality Assurance Project Plan
QA/QC	Quality Assurance/Quality Control
RAO	Removal Action Objectives
SAP	Sampling and Analysis Plan

SOW Statement of Work
Respondent Port of Tacoma
EPA U.S. Environmental Protection Agency

1.0 INTRODUCTION

1.1 General

This Statement of Work (SOW) provides an overview of the Time Critical Removal Action to be conducted by Respondent at the Site and outlines the tasks necessary to complete such Work. This SOW is consistent with the Comprehensive Environmental Response, Compensation and Liability Act (CERCLA) and the National Contingency Plan (NCP). Any discrepancies between the Administrative Settlement and Order on Consent (AOC or Settlement Agreement) and this SOW are unintended and, if there is a discrepancy, the Settlement Agreement will control in any interpretive disputes.

Site boundaries are depicted in the map which is AOC Appendix A.

Contaminant of concern is Tributyltin (TBT).

1.2 Oversight

All work products submitted to EPA are subject to EPA approval, including but not limited to, deliverables required by any Work Plan or the Settlement Agreement and additional deliverables that may be required under any Work Plan modifications. Respondent shall ensure that all plans, reports, and records are comprehensive, accurate, and consistent in content and format with the NCP and relevant EPA guidance unless otherwise specified by EPA.

Respondent shall coordinate monthly meetings and/or teleconferences with EPA to discuss the status of work described in this SOW. Monthly meetings may be cancelled or postponed upon agreement between EPA and Respondent.

Respondent shall also coordinate stakeholder briefings as appropriate with EPA and project stakeholders including, but not necessarily limited to, the Washington State Department of Ecology (Ecology) and/or the Puyallup and Muckleshoot Tribes (Tribes). These briefings may be combined with the EPA/Respondent monthly meeting or teleconference, as determined by EPA. Ecology and the Tribes may review deliverables submitted by Respondent and may submit comments to EPA for consideration. EPA and Respondent will review and confer on comments to be addressed in deliverables under this AOC (Table 1) Respondent shall fully incorporate and address all comments provided by EPA in the next draft deliverable.

1.3 Schedule

Refer to Table 1 for a summary of the deliverables required by this SOW and the associated schedule for submission of those deliverables.

1.4 Guidance

Respondent shall conduct all work and produce reports that are in accordance with: (i) the Settlement Agreement and this SOW; and (ii) any other EPA guidance relevant to the removal action to be conducted under the Settlement Agreement and this SOW. EPA's On-Scene Coordinator ("OSC") for the Site has the authority under the NCP to determine when application of any guidance would be inappropriate. Respondent may raise with the OSC any guidance issues it considers inappropriate during implementation of the Settlement Agreement or this SOW.

2.0 TIME CRITICAL REMOVAL ACTION

2.1 General

Respondent shall conduct a Time Critical Removal Action at the Site as provided in the Action Memorandum, which is AOC Appendix B, to respond to a threat to public health, welfare, or the environment at the Site.

2.2 Oversight and Guidance

In addition to the oversight activities described in Section 1.2, all removal activities performed at the Site will be conducted under the oversight and at the direction of the OSC. An EPA Superfund Technical Assessment and Response Team (START) contractor may provide technical assistance and support to the OSC in planning, field, and reporting activities for the Removal Action.

Respondent shall coordinate meetings and/or teleconferences with EPA, as needed, during performance of the Removal Action to discuss the status of work.

In addition to any applicable guidance identified in Section 1.4, the Removal Action and all sampling performed shall be conducted in accordance with the CERCLA Data Quality Objectives (DQOs) planning process (EPA QA/G-4, August 2000) and other applicable EPA guidance. EPA is aware that not all guidance used for time critical removal actions may be applicable to this Site.

2.3 Time Critical Removal Action

The primary objectives of the Time Critical Removal Action are as follows:

- To accomplish the removal action identified in the Removal Action Site Evaluation Report and the Action Memorandum prepared for the Site.
- To confirm that the removal action successfully eliminates the threat to human health and the environment posed by contaminants at the Site.

The Time Critical Removal Action shall include the following:

- Preparation and approval of a Removal Action Work Plan which must identify the schedule and work to be performed to accomplish the removal action identified in the Action Memorandum. The Work Plan shall include as appendices the following:
 - 1) Water Quality Monitoring and Protection Plan including dredge return water monitoring and associated Quality Assurance Project Plan (QAPP);
 - 2) Post-Dredge Confirmation Sampling Plan and associated QAPP and Health and Safety Plan.
- Performance of the Work under the Removal Action Work Plan.
- Preparation and approval of a Time Critical Removal Action Report, which will confirm adequate performance of the Removal Action.

Upon approval of the Removal Action Work Plan, Respondent shall implement the Removal Action.

Respondent shall submit the Time Critical Removal Action Report to EPA following completion of the Removal Action. The Time Critical Removal Action Report shall include the following:

- Description of removal activities undertaken.
- Description of activities undertaken to confirm that the removal action meets cleanup criteria identified in the Removal Site Evaluation Report and Action Memorandum.
- Locations, lab reports and summary of results of sample collection and analysis.
- Quality assurance review of analytical data associated with Post-Dredge Confirmation Sampling.
- Documentation of dredged material waste disposal.
- The Time Critical Removal Action Report shall be based on information and data available at the time the report is submitted to EPA.

All deliverables required by this Section 2.3 must be submitted in accordance with the schedule in Table 1.

3.0 COMMUNITY RELATIONS

The development and implementation of any community relations activities under this Settlement Agreement are the responsibility of EPA. The critical community relations planning steps performed by EPA include conducting community interviews and developing a community relations plan. Although implementation of the community relations plan is the responsibility of EPA, Respondent shall assist, when requested by EPA, by providing information regarding the Site's history, participating in public meetings, and preparing fact sheets for distribution to the general public. In addition, Respondent shall establish a community information repository near the Site, to house one copy of the administrative record. The extent of community relations activities by potentially responsible parties (PRPs) is left to the discretion of EPA. Respondent's community relations responsibilities, if any, are specified in the community relations plan. Any PRP-conducted community relations activities will be subject to oversight by EPA.

4.0 SCHEDULE

Refer to Table 1 for a summary of the deliverables required by this SOW and the associated schedule for submission of those deliverables.

5.0 ELECTRONIC DATA SUBMITTAL

Respondent shall submit results of field measurements and laboratory analyses of confirmational samples to be compiled and used in the Time Critical Removal Action Report in electronic form. This data will also be provided to EPA in a format usable to EPA and EPA's consultants for the purpose of assessing data relationships and data gaps at the site. Monitoring data may be provided in summarized form.

Respondent shall provide results of field measurements, laboratory analyses of samples, and other data relevant to accomplishing the tasks in this SOW, such as CAD files of base maps and other graphic presentations of data, in a usable format to facilitate EPA review of data submittals.

Electronic data includes Site or project-level data, maps or graphical data, sampling data, analytical laboratory data, etc. These data files are generally organized in a readily exportable format (e.g. tabular, dbf, xml, etc.) and allow the regulatory agency or data recipient to easily

import the information into a database or to quantitatively analyze the data independently. The data should be submitted in an unsecured format for EPA review.

Examples of data that should be submitted electronically:

1. Site Map:
 - a. Preference is for GIS layer file or computer-aided design (CAD) format with all relevant surface features; however PDF or other file format may be acceptable.
2. Boring Logs and Well Construction Details:
 - a. X, Y, and Z coordinates, and location ID.
 - b. Ground surface elevation, top of casing elevation, depth to lithologic units, lithologic descriptions, depth to well construction material, well construction material type, diameter of casing, drilling method, well development information, etc.
 - c. Field test data (e.g., photoionization detector (PID), field x-ray fluorescence (XRF), immunoassay, etc.).
 - d. Aquifer slug test or pump test data.
 - e. Geophysical test data.
3. Location Data:
 - a. X, Y, and Z coordinates.
 - b. Coordinate system and projection in use.
4. Depth to Water Data:
 - a. Location ID and X, Y, and Z coordinates.
 - b. Depth to water.
 - c. Date and time of measurement.
 - d. Sample collection pumping rates/purge rates.
5. Lab Data:
 - a. Chain-of-custody information, e.g., sample collection information (date/time collected, sample matrix, etc.), preservatives used, sample containers used, and condition after transport, etc.
 - b. Lab results, e.g., analyses performed, parameters reported, analytical results, and analytical method detection and reporting limits, etc.
 - c. QA/QC information, e.g., detection limits, QA/QC standard failures, laboratory narrative regarding non-compliance, etc.
6. Electronic Reports:
 - a. Complete electronic copies of all project documents and reports.
 - b. Complete electronic copies of all sampling field books and laboratory log books.

Historical information already stored in an electronic format will be provided to EPA and/or its contractor(s) upon request. A brief description of newly acquired data will be included in each monthly report. Newly acquired data will be transmitted within two weeks of its validation unless a longer reporting time to EPA is agreed upon.

All documents required to be submitted by this SOW shall be provided in its original format and in web-posting ready format (PDF), as directed by EPA. The maximum size document that may be electronically mailed (email) to EPA is 25 MBs per email. Packages larger than 25 MBs should be sent on CD to retain file linkages. Respondent shall follow the following procedures for providing web-posting ready format documents unless otherwise directed by EPA:

- Bookmark documents longer than 10 pages for easier navigation (e.g., chapters).
- Ensure that file/document properties/initial view is for “bookmarks panel and page” if there are bookmarks.
- For documents composed of multiple files, link together with a starter file that is less than 2 MB, i.e., the document’s executive summary. The executive summary should have a bookmarks panel with bookmark links to the other files (as an example, look at the website, T4 EE/CA). Ensure that all files are saved to the same folder, rather than multiple folders so that the linkage is retained during web posting.
- Bookmarks to other files should indicate the name of that file (and size of that file, if over 1 MB).
- “Tag” the document for accessibility if this was not done by the source application (advanced/accessibility/tag) for section 508 compliance.
- Enter document properties: 1) title, author (should be XXXX for EPA Region 10), 2) subject, and 3) keywords.
- “Add links” (advanced/links/create links from URLs in document) to the document so that they can be used to go to the website directly from the document. Links need to start with “http:”etc. to be usable.

6.0 REFERENCES

6.1 References Cited in Document

The following list, although not comprehensive, comprises many of the regulations and guidance documents that apply to the Removal Process:

The National Oil and Hazardous Substance Pollution Contingency Plan (NCP), 40 CFR Part 300 et seq.

“Interim Guidance on Potentially Responsible Party Participation in Remedial Investigation and Feasibility Studies,” U.S. EPA, Office of Waste Programs Enforcement, Appendix A to OSWER Directive No. 9355.3-01.

“Guidance on Oversight of Potentially Responsible Party Remedial Investigations and Feasibility Studies,” Volumes I and II, U.S. EPA, Office of Waste Programs Enforcement, July 1991, OSWER Directive No. 9835.1(c) and .1(d).

“A Compendium of Superfund Field Operations Methods,” Two Volumes, U.S. EPA, Office of Emergency and Remedial Response, EPA/540/P-87/001a, August 1987, OSWER Directive No. 9355.0-14.

“RCRA Public Participation Manual,” U.S. EPA, Sept. 1996, No. 530-R-96-007.

“Guidance for the Data Quality Objectives Process EPA QA/G-4,” U.S. EPA, Office of Environmental Information, EPA/600/R-96/055, August 2000.

“Guidance for the Preparation of Standard Operating Procedures QA-G-6. U.S. EPA Office of Environmental Information, EPA/240/B-01/004, March 2001.

“EPA Requirements for Quality Assurance Project Plans,” USEPA. EPA QA/R5, March 2001.

“EPA Requirements for Quality Management Plans,” U.S. EPA, Office of Emergency

and Remedial Response and Office of Waste Programs Enforcement, EPA QA/R-2, EPA/240/B-01/002, March 2001 (revised May 2006).

“EPA Guidance on Quality Assurance Project Plans,” QA/G-5, U.S. EPA, Office of Emergency and Remedial Response and Office of Waste Programs Enforcement, EPA/600/R-98/018, February 1998.

“Interim Guidance on Compliance with Applicable or Relevant and Appropriate Requirements,” U.S. EPA, Office of Emergency and Remedial Response, July 9, 1987, OSWER Directive No. 9234.0-05.

“CERCLA Compliance with Other Laws Manual,” Two Volumes, U.S. EPA, Office of Emergency and Remedial Response, August 1988 (draft), OSWER Directive No. 9234.1-01 and -02.

“Draft Guidance on Preparing Superfund Decision Documents,” U.S. EPA, Office of Emergency and Remedial Response, March 1988, OSWER Directive No. 9355.3-02.

“Risk Assessment Guidance for Superfund--Volume I, Human Health Evaluation Manual (Part A),” December 1989, EPA/540/1-89/002.

“Risk Assessment Guidance for Superfund--Volume II Environmental Evaluation Manual,” March 1989, EPA/540/1-89/001.

“Ecological Risk Assessment Guidance for Superfund: Process for Designing and Conducting Ecological Risk Assessments,” U.S. EPA, OSWER Directive No. 9285.7-25, June 1998, EPA/540-R-97-006.

“Guidance for Data Usability in Risk Assessment,” October 1990, EPA/540/G-90/008.

“Performance of Risk Assessments in Remedial Investigation/ Feasibility Studies (RI/FSs) Conducted by Potentially Responsible Parties (PRPs),” August 28, 1990, OSWER Directive No. 9835.15.

“Supplemental Guidance on Performing Risk Assessments in Remedial Investigation/Feasibility Studies (RI/FSs) Conducted by Potentially Responsible Parties (PRPs),” July 1991, OSWER Directive No. 9835.15(a).

“Supplemental Risk Assessment Guidance for Superfund,” Region 10 U.S. EPA, Health and Environmental Assessment Section, August 1991.

“Health and Safety Requirements of Employees Employed in Field Activities,” U.S. EPA, Office of Emergency and Remedial Response, July 12, 1981, EPA Order No. 1440.2.

OSHA Regulations in 29 CFR 1910.120 (Federal Register 45654, December 19, 1986).

“Interim guidance on Administrative Records for Selection of CERCLA Response Actions,” U.S. EPA, Office of Waste Programs Enforcement, March 1, 1989, OSWER Directive No. 9833.3A.

“Community Relations in Superfund: A Handbook,” U.S. EPA, Office of Emergency and Remedial Response, January 1992, OSWER Directive No. 9320.0-03C.

“Community Relations During Enforcement Activities and Development of the

Administrative Record,” U.S. EPA, Office of Waste Programs Enforcement, November 1988, OSWER Directive No. 9836.0-1A.

“Institutional Controls: A Guide to Implementing, Monitoring, and Enforcing Institutional Controls at Superfund, Brownfields, Federal Facility, UST and RCRA Corrective Action Cleanups,” [Draft] U.S. EPA OSWER, March 2003.

TABLE 1 – Schedule of Project Deliverables¹		
TASK	DELIVERABLE	DUE DATE
Removal Action Work Plan	Draft Removal Action Work Plan	Within 60 days after the effective date of the Settlement Agreement.
	Final Removal Action Work Plan	Within 14 days of Respondent’s receipt of EPA’s comments.
Time Critical Removal Action Report	Draft Time Critical Removal Action Report	Within 90 days of Respondent’s completion of site work, including confirmational sampling and waste disposal.
	Final Time Critical Removal Action Report	Within 30 days of Respondent’s receipt of EPA’s comments.

¹ All deadlines in this Table are subject to extension as set forth in the Settlement Agreement, including without limitation, for *Force Majeure* events.

**APPENDIX F –
REMOVAL ACTION WORK
PLAN (RAWP), DATED
JANUARY 27, 2015**

APPENDIX A POST-DREDGE CONFIRMATIONAL
SAMPLING PLAN AND ASSOCIATED HEALTH AND
SAFETY PLAN

APPENDIX B WATER QUALITY MONITORING AND
PROTECTION PLAN (WQMPP)

APPENDIX C ASPECT CONSULTING DEWATERING
RETURN WATER TREATMENT TECHNICAL
MEMORANDUM

Pier 4 Phase 1 Removal Action Project

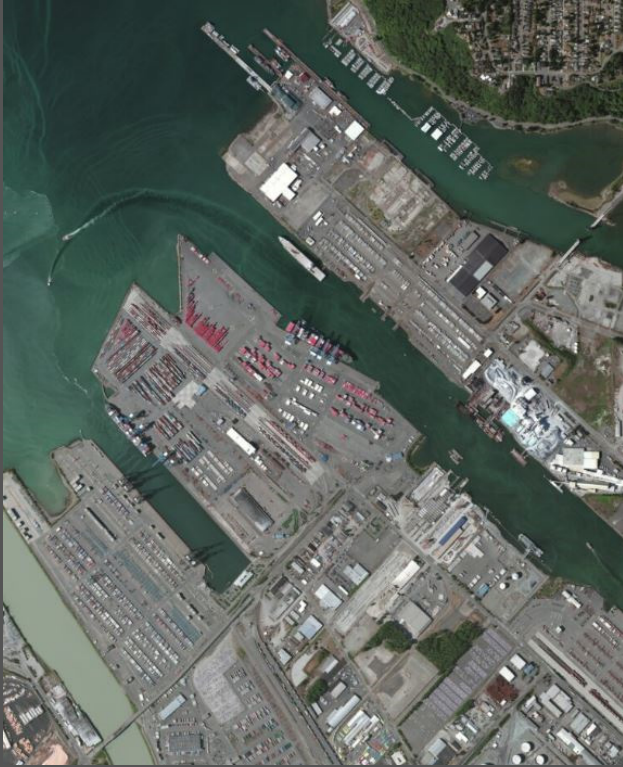

Removal Action Work Plan

Prepared for

Port of Tacoma
P.O. Box 1837
Tacoma, Washington 98401

January 27, 2015



FLOYD | SNIDER
strategy ■ science ■ engineering
Two Union Square • 601 Union Street • Suite 600
Seattle, Washington 98101 • tel: 206.292.2078

LIMITATIONS

This report has been prepared for the exclusive use of Port of Tacoma, their authorized agents, and regulatory agencies. It has been prepared following the described methods and information available at the time of the work. No other party should use this report for any purpose other than that originally intended, unless Floyd|Snider agrees in advance to such reliance in writing. The information contained herein should not be utilized for any purpose or project except the one originally intended. Under no circumstances shall this document be altered, updated, or revised without written authorization of Floyd|Snider.

Table of Contents

1.0 Introduction 1-1

 1.1 SITE LOCATION AND BACKGROUND 1-1

 1.2 REMOVAL SITE EVALUATION FINDINGS 1-2

 1.3 DOCUMENT ORGANIZATION 1-3

2.0 Site Description 2-1

3.0 Overview of Time Critical Removal Action..... 3-1

4.0 Applicable or Relevant and Appropriate Requirements..... 4-1

5.0 Removal Action Work Elements and Protection Measures 5-1

 5.1 GENERAL WATER QUALITY PROTECTION MEASURES 5-1

 5.2 OVER-WATER DEMOLITION OF THE MAJORITY OF THE PIER 4 STRUCTURE 5-2

 5.2.1 Best Management Practices 5-2

 5.3 NAVIGATION LIGHT PILE REMOVAL AND INSTALLATION 5-3

 5.3.1 Best Management Practices 5-4

 5.4 VIBRATORY PILE EXTRACTION..... 5-4

 5.4.1 Best Management Practices 5-4

 5.5 DREDGING 5-5

 5.5.1 Best Management Practices 5-8

 5.6 TRANSLOADING 5-10

 5.6.1 Best Management Practices 5-11

 5.7 DEWATERING TREATMENT SYSTEM AND DREDGE RETURN WATER 5-14

 5.8 POTENTIAL POST-DREDGE SAND PLACEMENT 5-15

 5.8.1 Best Management Practices 5-15

 5.9 CONCRETE TEST PILE PROGRAM..... 5-15

 5.9.1 Best Management Practices 5-16

6.0 Health and Safety 6-1

7.0 Access to Removal Action Area 7-1

8.0 Project Water Quality Monitoring and Confirmational Sampling..... 8-1

 8.1 WATER QUALITY MONITORING 8-1

 8.2 POST-DREDGE CONFIRMATIONAL AND PERIMETER SAMPLING 8-1

9.0 Project Schedule and Post-Construction Reporting 9-1
 9.1 SCHEDULE 9-1
 9.2 REPORTING 9-2
10.0 References 10-1

List of Tables

Table 4.1 Applicable or Relevant and Appropriate Requirements

List of Figures

Figure 1.1 Site Vicinity Map
Figure 1.2 Location Map of Piers 3 and 4 and Blair Waterway
Figure 5.1 Phase 1 Site and Demolition Plan
Figure 5.2 Phase 1 Dredge Plan
Figure 5.3 Dredge Section A
Figure 5.4 Dredge Section B
Figure 5.5 Dredge Section C
Figure 5.6 Transload Site Location
Figure 5.7 Transload Site Conditions

List of Appendices

Appendix A Post-Dredge Confirmational Sampling Plan and Associated Health and Safety Plan
Appendix B Water Quality Monitoring and Protection Plan
Appendix C Aspect Consulting Dewatering Return Water Treatment Technical Memorandum

List of Acronyms and Abbreviations

Acronym/ Abbreviation	Definition
AOC	Agreed order on consent
ARAR	Applicable or relevant and appropriate requirement
bml	Below mudline
BMP	Best management practice
BT	Bioaccumulation Trigger
CERCLA	Comprehensive Environmental Response, Compensation, and Liability Act
COC	Chemical of concern
CY	Cubic yards
DGPS	Differential Global Positioning System
DMMP	Dredged Material Management Program
DNR	Washington State Department of Natural Resources
Ecology	Washington State Department of Ecology
GAC	Granular activated carbon
gpm	Gallons per minute
HASP	Health and safety plan
µg/kg	Micrograms per kilogram
µg/L	Micrograms per liter
MLLW	Mean lower low water
NMFS	National Marine Fisheries Service
NPDES	National Pollutant Discharge Elimination System
OHWM	Ordinary high water mark
OSC	On-Scene Coordinator
OSHA	Occupational Safety and Health Administration
Phase 1 Removal Action	Pier 4 Phase 1 Removal Action Project
Phase 2 Project	Pier 4 Phase 2 Reconfiguration Project
Port	Port of Tacoma
QA	Quality assurance

Acronym/ Abbreviation	Definition
QAPP	Quality Assurance Project Plan
RAWP	Removal Action Work Plan
RSER	Removal Site Evaluation Report
SL	Screening level
SWPPP	Stormwater Pollution Prevention Plan
TBT	Tributyltin
Transload Site	APM Terminals
TSS	Total suspended solids
TTD	Transload, Transport, and Disposal
USACE	U.S. Army Corps of Engineers
USEPA	U.S. Environmental Protection Agency
USFWS	U.S. Fish and Wildlife Service
WAC	Washington Administrative Code
WDFW	Washington Department of Fish and Wildlife
WQMPP	Water Quality Monitoring and Protection Plan

1.0 Introduction

This Removal Action Work Plan (RAWP) has been prepared on behalf of the Port of Tacoma (the Port) and provides a summary of the activities to be completed during the Pier 4 Phase 1 Removal Action Project (Phase 1 Removal Action) to address tributyltin (TBT)-contaminated sediments present at Pier 4. The Pier 4 site is located on the west side of the northern portion of the Blair Waterway that lies within the Port's Industrial Development District, adjacent to Commencement Bay in Tacoma, Washington (Figure 1.1).

The Port is in the process of the design and permitting of the reconfiguration of Pier 4, which consists of aligning Pier 4 with Pier 3 within the Husky Container Terminal. As part of this process, Floyd|Snider, on behalf of the Port, conducted multiple soil and sediment sampling events in 2013 under the Dredged Material Management Program (DMMP) for the characterization of the project cutback material for open water disposal or beneficial habitat reuse. The results of the characterization events identified TBT-contaminated sediments underneath and at the face of Pier 4. In consultation with the U.S. Environmental Protection Agency (USEPA) and the DMMP representatives, and based on the TBT concentrations detected at Pier 4, the Port entered into an agreed order on consent (AOC) with USEPA in June 2014. The AOC called for a removal site evaluation, which was conducted in July 2014. The results of the removal site evaluation, as well as a recommended removal action, are summarized in the *Pier 4 Phase 1 Removal Action Project Removal Site Evaluation Report* (RSER; Floyd|Snider 2014a). The Port is entering into a second AOC with USEPA for the implementation of the Phase 1 Removal Action. This AOC also includes the preparation of the RAWP and USEPA's Action Memorandum.

The purpose of this RAWP is to summarize the work necessary to complete the Time Critical Removal Action identified in the RSER and Action Memorandum. It identifies best management practices (BMPs) for construction activities, and overviews the water quality protection monitoring and confirmational and compliance sampling activities that will be conducted as part of the project under USEPA oversight, in order to confirm that the Phase 1 Removal Action successfully eliminates the threat to human health and the environment posed by contamination at the Pier 4 site. Per the AOC between the Port and USEPA, the USEPA On-Scene Coordinator (OSC) may make modifications to this RAWP in writing or by oral direction after it has been approved. Any modification to the approved RAWP requested by the Port must also be pre-approved by the OSC.

1.1 SITE LOCATION AND BACKGROUND

Pier 4 is an active terminal that is currently operated by Husky Container Terminal and Stevedoring, Inc. for offloading shipping containers to trucks and railcars for transport. A site location map is provided in Figure 1.2. The Port is proposing to clean up approximately 49,000 cubic yards (CY) of TBT-contaminated sediments located under Pier 4, as part of an AOC with USEPA, and then reconfigure and reconstruct Pier 4 to be in alignment with Pier 3 within the Husky Container Terminal. Once the project is completed, Pier 3 and Pier 4 will have a combined marginal pier length of 2,954 feet and will be capable of simultaneously berthing

two ultra-large container ships, 18,000 twenty-foot-equivalent-unit ships that are approximately 1,300 feet long and 205 feet wide. The reconfigured Pier 4 will be able to accommodate up to six 100-foot-gauge cranes capable of loading ships that are 24-containers-wide.

The work occurring at Pier 4 will have two distinct work phases: (1) the Phase 1 Removal Action, which includes a USEPA-ordered cleanup of contaminated sediment (and is the subject of this RAWP), and (2) the Pier 4 Phase 2 Reconfiguration Project (Phase 2 Project), which includes reconfiguration of the existing pier. Phase 2 includes an additional cutback and dredge of approximately 500,000 CY and will only be undertaken after Phase 1 is determined by USEPA to be complete. The project, including both phases, is planned to be completed over 3 years, with work tentatively scheduled to be conducted between 2015 and early 2018. The Phase 1 Removal Action is described in detail in this RAWP.

1.2 REMOVAL SITE EVALUATION FINDINGS

The RSER, which was completed in September 2014, summarized the results of three sediment sampling events undertaken in 2013 to fulfill DMMP requirements. The RSER also documented the removal site evaluation soil, sediment, and ambient site water sampling event that was conducted in July 2014 under the USEPA AOC (Floyd|Snider 2014a). The RSER delineated TBT sediment contamination at concentrations greater than the DMMP bulk sediment Bioaccumulation Trigger (BT) of 73 micrograms per kilogram ($\mu\text{g}/\text{kg}$)¹ in fill units overlying native sediments and delineated TBT hot spots within the zone of contaminated fill. Although the DMMP User's Manual specifies porewater analysis as the preferred measurement of assessing TBT toxicity (USACE 2014), bulk sediment TBT concentrations were measured during these sampling events because the bulk method has a substantially longer holding time than the porewater TBT method and allowed for tiered analysis to fully delineate the extents of site contamination.

The zone of contaminated fill extends from the southern end of the pier, approximately 800 feet to the northwest along the pier face. The zone of contamination along the pier face is generally less than 10 feet thick, except in the south-central portion of the pier where TBT-contaminated fill is present up to 11 feet below mudline (bml). Under the pier, TBT contamination is present from below (i.e., down slope of) elevation -2 feet mean lower low water (MLLW) down to the toe of the slope at the pier face. The thickness of TBT-contaminated sediments at the toe of the slope at the pier face is up to approximately 11 feet and thins to less than 3 feet thick on the under-pier slope at the shoreward edge of the contaminated zone.

¹ Previous versions of the DMMP User Manual, which were available during Sampling and Analysis Plan development and the sampling event in April 2013, listed 73 $\mu\text{g}/\text{kg}$ as both the DMMP bulk sediment TBT screening level (SL) and BT. These versions of the User Manual also listed 0.15 $\mu\text{g}/\text{L}$ as both the DMMP porewater TBT SL and BT. Therefore, throughout the project, the DMMP TBT bulk sediment and porewater value of 73 $\mu\text{g}/\text{kg}$ and 0.15 $\mu\text{g}/\text{L}$ has been, and is in this plan, referred to as an SL. DMMP guidance notes that measurement of TBT in interstitial water may provide a more direct measure of potential bioavailability, and hence toxicity, than bulk sediment concentrations. Bulk values were established to "screen out" areas with negligible risks.

TBT was not detected in the ambient site water sample that was collected from 2 meters above the highly contaminated sediments, using low-level analysis with a reporting limit less than the USEPA chronic marine aquatic life water quality criterion of 0.0074 micrograms per liter ($\mu\text{g/L}$). This non-detection result suggests that overlying water quality at the Pier 4 site may not be affected by TBT contamination in sediments under existing conditions.

Data from dredge elutriate testing performed using two samples collected within the area of greatest TBT sediment contamination also suggest that TBT concentrations in the water column from sediment resuspension at the point of dredging are unlikely to exceed the USEPA acute marine aquatic life water quality criterion of 0.42 $\mu\text{g/L}$.

Additionally, DREDGE modeling results indicate attenuation of TBT and total suspended solids (TSS) between the point of dredging and the anticipated points of compliance such that the dredge activities should not adversely affect water quality at the points of compliance and water quality criteria exceedances are not expected.

The removal action includes dredging of TBT-contaminated sediments exceeding the TBT project SL as determined based on the existing sampling event results and the results of post-dredge confirmational sampling as described in Appendix A. The extent of the Phase 1 Removal Action dredge prism is described in detail in Section 5.5 of this RAWP.

1.3 DOCUMENT ORGANIZATION

The rest of this RAWP is organized as described below:

- **Section 2.0—Site Description.** Provides information on Pier 4, including the environmental setting, and land use and ownership.
- **Section 3.0—Overview of the Time Critical Removal Action.** Describes the activities to be completed as part of the Phase 1 Removal Action, including: mobilization; pier demolition; pile extraction; dredging and transport of top of slope clean 9,000 CY of sediments (including clean riprap removal); dredging and transloading of contaminated sediments; water quality monitoring during removal activities; dredge return water treatment; post-dredge confirmational sampling; potential sand placement in the hot spots; the concrete test pile program; and demobilization.
- **Section 4.0—Applicable or Relevant and Appropriate Requirements.** Identifies applicable laws and regulations relevant to implementing the Phase 1 Removal Action at Pier 4.
- **Section 5.0—Removal Action Work Elements and Protection Measures.** Discusses the construction sequence and schedule, mobilization and staging, and BMPs required during demolition, pile extraction and installation, dredging, transload, dredge return water treatment, potential post-dredge material placement, the concrete test pile program, and disposal.

- **Section 6.0—Health and Safety.** Provides a description and reference to the health and safety plans (HASP) for post-dredge confirmational sampling and provisions for submittal of HASPs by the selected removal action contractor.
- **Section 7.0—Access to Removal Action Area.** Describes coordination with the Port and USEPA for project site access.
- **Section 8.0—Project Water Quality Monitoring and Confirmational Sampling.** Presents an overview of the water quality monitoring and post-dredge confirmational sampling that will be done during the Phase 1 Removal Action.
- **Section 9.0—Project Schedule and Post-Construction Reporting.** Presents the schedule of the removal action activities and follow-up documentation, including an overview of the Time Critical Removal Action Report that will include water quality monitoring and post-dredge confirmation sampling results.
- **Section 10.0—References.** Provides a list of materials cited in the RAWP.

2.0 Site Description

As described in Section 1.1, the Pier 4 project site is an active shipping terminal on the west side of the northern portion of the Blair Waterway and is owned by the Port. The project area was originally part of the Puyallup River delta, which spread northwest into Commencement Bay. Prior to filling and construction of the current Port, the area within the shoreline cutback was tidal flats with an approximate elevation of +10 MLLW (Hart Crowser 1974). The waterway (originally called the Wapato Waterway) was constructed from Commencement Bay to East 11th Street by local interests in the 1920s, 1930s, and 1940s by the dredging of intertidal and shallow subtidal lands and filling adjacent lands to construct uplands.

Renamed the Blair Waterway in 1969 after reaching its current configuration, the waterway is approximately 2.6 miles long. Several dredging projects undertaken since 1969 have deepened the navigation channel to -51 feet MLLW and the channel width in the vicinity of the Pier 4 project site is 343 feet. Since its creation, the Blair Waterway has been actively operated, managed, and maintained as an industrial and commercial navigable waterway.

The Pier 4 project site consists of a vessel berthing area with an average water depth of 45 to 63 feet, with tidal fluctuations of up to 14 feet. The pier is constructed over a 2:1 riprap rock armored slope with approximately 2 feet of armor, and is composed of precast concrete deck panels, multiple inches of rock ballast, and multiple inches of surface asphalt covering a pile-supported deck that supports container cranes. The adjacent asphalt paved uplands areas are used for container storage and truck travel lanes. Pier 4 most recently underwent maintenance dredging of the berth area in 2011.

The Pier 4 project area is zoned for port maritime and industrial use. It is bounded to the south by the Fairliner mitigation area, Concrete Technology Corporation, and Washington United Terminal, and is across the waterway from Totem Ocean Trailer Express.

Additionally, consistent with the Port's experience on other area projects regarding cultural resources, Section 106 compliance, and Tribal informal consultations, due to the project location in the north central filled area of the tideflats, archaeological monitoring will not be required during subsurface work. No buildings, structures or objects are over 50 years of age that will be directly or indirectly impacted by the project.

3.0 Overview of Time Critical Removal Action

The Phase 1 Removal Action will include specific work elements necessary to facilitate the removal of the TBT-contaminated sediments and maintain waterway navigation safety. The Phase 1 Removal Action includes the following activities that are also described in detail in Section 5.0:

- **Mobilization and Staging of Equipment and Materials.** Project activities will commence with mobilization and staging. Materials and equipment will be mobilized to the Pier 4 site and the transload site at APM Terminals (the Transload Site) and staged in upland locations at the terminal. Dredge and disposal barges will also be mobilized to the sites.
- **Demolition of the Majority of the Existing Pier 4 Structure.** The existing Pier 4 structure, approximately 133,780 square feet waterward of ordinary high water mark [OHWM] and including the existing bulkhead, will be demolished. This includes the existing Pier 4 deck between Bents 92 and 144 (approximately 1,040 feet). The existing fender system, utilities, and other appurtenances will be removed and will be followed by the demolition of the existing crane beam, bull rail, and all crane appurtenances. Demolition of the pier deck, deck beams, and pile caps will then take place, followed by pile extraction, as described below.
- **Navigation Light Pile Removal and Installation.** Removal and relocation of navigation lights will be done in coordination with the U.S. Coast Guard and the Puget Sound Pilots. The existing navigation light on the south end of Pier 4 will be relocated to accommodate demolition of the pier and, based on communications with the Puget Sound Pilots and U.S. Coast Guard, it is also necessary to relocate its companion light (pile-supported) located on the other side of the Blair Waterway. To facilitate pier demolition, temporary navigation lights will be installed as necessary to maintain a safe navigable waterway per U.S. Coast Guard requirements.
- **Vibratory Pile Extraction.** The demolition of the existing timber-pile-supported fender system will include dismantling the existing chocks and wales and removing approximately 87 14-inch-diameter creosote-treated timber piles and 22 20-inch-diameter steel pipe piles. This will result in the removal of approximately 2,670 square feet of over-water coverage. The demolition of the existing concrete piles will include removing approximately 1,047 16.5-inch-diameter concrete piles waterward of OHWM. This will result in a total removal of 1,784 square feet of over-water coverage for all piles including: concrete, creosote-treated timber, and steel pipe piles.
- **Dredging of Approximately 49,000 CY of TBT-Contaminated Sediments, and Approximately 9,000 CY of Clean Sediments.** Approximately 49,000 CY of contaminated material is located under the mid- to lower-slope of the pier and the

pier face. In order to access this material, approximately 9,000 CY² of clean material that is suitable for open water disposal will first be removed from the existing bulkhead and down the top of the slope to an approximate elevation of -2 feet MLLW. In order to facilitate the dredging of the approximately 9,000 CY of clean sediment, prior to dredging, the 2-foot layer of riprap armor (approximately 2,300 CY) will be removed and disposed of at an appropriate upland facility or reused by the Port, as described in Section 5.5.

- **Temporary Slope Stabilization at the Substation.** After removal of the clean sediment at the top of the slope, riprap armoring will be placed in the vicinity of the existing electrical substation to prevent undermining of the structure.
- **Water Quality Monitoring during Phase 1 Removal Action.** Water quality monitoring will be performed to ensure that near-water, in-water, and over-water activities, do not result in exceedances of the applicable water quality standards at the point(s) of compliance. A combination of instrumented, visual, and chemical TBT monitoring is proposed for this project. Water quality monitoring for the over-water, near-water, and in-water construction phases, as well as dredge return water management activities are briefly summarized in Section 8.1 and provided in detail in the Water Quality Monitoring and Protection Plan (WQMPP) in Appendix B.
- **Transloading and Upland Disposal of Dredged Material.** TBT-contaminated material will be moved from water-tight scows from the dredge area on the Blair Waterway to the Transload Site at APM Terminal located along the Sitcum Waterway. Material will be transferred to shore for stockpiling and dewatering and load out for upland disposal, as discussed in more detail in Section 5.6. Transfer, stockpile, and load-out areas will be designed to collect all process water for treatment prior to discharge to Commencement Bay.
- **Management and Treatment of Contaminated Dredge Return Water.** The sediment arriving at the Transload Site will contain an approximate 1:1 ratio of sediment and water, such that approximately 8 to 10 million gallons of water will need to be dewatered and treated. The removal of dissolved TBT from the water will require a treatment train including: primary screening and settling to remove large particles; coagulation and settling; mixed-media filtration to remove TSS, turbidity, and adsorbed TBT; and, finally, granular activated carbon (GAC) as a final polishing step to remove dissolved TBT. A summary of the process is included in Section 5.7, with detail provided in Appendix C.
- **Post-Dredge Confirmational and Perimeter Sampling and Surveying.** Post-dredge confirmational sampling, will be conducted following the completion of dredging to confirm that the removal action achieved the project objectives and completion requirements, as well as to confirm the suitability of the underlying cutback material to be dredged under Phase 2 for open water disposal or beneficial

² The approximately 9,000 CY of clean sediments does not include the upper 2 feet of riprap armoring that will be removed separately from the clean material.

use. Per the second AOC, split or duplicate samples may also be provided to the USEPA upon request. A detailed Post-Dredge Confirmational Sampling Plan, including quality assurance (QA) protocols and objectives consistent with the Quality Assurance Project Plan (QAPP) for the Pier 4 removal site evaluation, is provided in Appendix A.

- **Concrete Test Pile Program.** To facilitate the reestablishment of the removed pier, a Test pile program is included in Phase 1 to confirm design assumptions made about installation and structural capacity of concrete piles that will be installed in Phase 2. The program will consist of installing four 24-inch-diameter octagonal concrete piles along the length of the Pier 4 slope and will record data associated with the amount of energy required to drive each pile. The piles will be driven using an impact hammer and will be instrumented to collect the necessary data. The piles will be removed upon completion of testing.
- **Demobilization.** Demobilization will include the contractor's closeout of the project. Work will include final as-built surveys, work area cleanup, and removal of construction materials and equipment from both the Pier 4 site and the Transload Site.

4.0 Applicable or Relevant and Appropriate Requirements

The Phase 1 Removal Action, including dredged material transloading and dewatering project activities, must comply with applicable local, state, and federal laws. Together, these regulations and laws are identified as applicable or relevant and appropriate requirements (ARARs) for the Phase 1 Removal Action. The term “applicable requirements” refers to regulatory cleanup standards, standards of control, and other environmental requirements, criteria, or limitations established under state or federal law that specifically address a remedial action, location, chemical of concern (COC), or other circumstance at the site. The “relevant and appropriate” requirements were considered and determined to be applicable to the removal action. These ARARs are presented in Table 4.1. The removal action addresses the known ARARs by prescribing BMPs to be used during performance of the Phase 1 Removal Action.

As described above, no federal, state, or local permits are required nor will they be sought for on-site response actions conducted pursuant to Comprehensive Environmental Response, Compensation, and Liability Act (CERCLA) Sections 104, 106, 120, 121, or 122 (refer to 40 CFR 300.400(e)(1)). Instead, USEPA and the Port have identified ARARs and any other advisories, criteria, or guidance to be considered. Remedial actions conducted under an AOC with USEPA are also exempt from procedural requirements that are required by state and local ARARs, such as permitting and approval requirements; however, remedial actions must demonstrate compliance with the substantive requirements of those ARARs. This exemption applies to procedural permitting requirements under the Washington State Water Pollution Control Act, the Solid Waste Management Act, the Shoreline Management Act, and local laws requiring permitting such as City of Tacoma regulations (Table 4.1).

The USEPA also submitted a Phase 1 Project Description (Floyd | Snider 2014b) to tribes and local, state and federal agencies including the Puyallup Tribe, City of Tacoma, Washington State Department of Ecology (Ecology), Washington Department of Fish and Wildlife (WDFW), Washington State Department of Natural Resources (DNR), U.S. Army Corps of Engineers (USACE)/DMMP, United States Coast Guard, and National Oceanic and Atmospheric Administration National Marine Fisheries Service as a formal request for comment on the work to be conducted and BMPs to be implemented. The task-specific BMPs, which are listed Section 5.0, incorporate the feedback received from these entities.

Although implementation of the community relations plan is the responsibility of USEPA, the Port will assist, when requested by USEPA, by providing information regarding the site’s history, participating in public meetings, and preparing fact sheets for distribution to the general public. In addition, the Port established a community information repository at the offices of Citizens for a Healthy Bay, located at 535 Dock Street, Suite 213, Tacoma, Washington 98402, to house one copy of the administrative record.

5.0 Removal Action Work Elements and Protection Measures

This section describes the Phase 1 Removal Action work elements and protection measures that will be implemented during all in-water work, near-water work, and over-water work (as specified below) to minimize impacts on aquatic life and water quality. Figure 5.1 presents the Phase 1 Removal Action Site and Demolition Plan. The construction starting dates provided in the RAWP are based on the current design schedule; however, the Contractor will develop a detailed construction schedule for project activities within the required work windows, which include pile extraction starting no earlier than June 15, 2015 and TBT-contaminated dredging starting no earlier than August 1, 2015.

5.1 GENERAL WATER QUALITY PROTECTION MEASURES

The project elements have been designed to minimize adverse impacts on the environment due to the project activities, specifically, in-water work below the OHWM (i.e., pile removal and installation, dredging) and above- or near-water work (deck demolition and general over-water work).

The following general water quality protection measures will be implemented on a project-wide basis to reduce, eliminate, or minimize the effects of the removal action on water quality:

- No materials will be stockpiled below the OHWM in any water body.
- Fueling and servicing of all equipment, with the exception of barge derricks, will be confined to an established staging area. Barge derricks will be fueled and serviced while they float. Spill containment systems will be adequate to contain all fuel leaks.
- At least two oil-absorbing floating booms, appropriate for the size of the work area, will be available on-site whenever heavy equipment operates within 150 feet of open water and there is a potential for hazardous materials to enter surface waters. The booms will be stored in a location that facilitates their immediate deployment in the event of a spill.
- Barges will not ground out or rest on the substrate or be over or within 25 feet of vegetated shallows (except where such vegetation is limited to state-designated noxious weeds).
- The bottom of any structure, vessel, watercraft grid, or watercraft lift will be at least 1 foot above the level of the substrate during all water levels.
- Equipment and vehicles will be stored in established staging areas when not in use (excluding cranes, which cannot be moved easily).
- A written spill prevention, control, and countermeasures plan will be prepared for activities that include the use of heavy equipment. The plan will describe measures to prevent or reduce impacts due to accidental leaks or spills, as well as all hazardous

- materials that will be used, their proper storage and handling, and the methods that will be used to monitor their use.
- Upon advance notice, the Port will provide access to the construction site for representatives of USEPA, City of Tacoma, WDFW, USACE, U.S. Fish and Wildlife Service (USFWS)/National Marine Fisheries Service (NMFS; hereafter referred to as “the Services”), the Puyallup Tribe of Indians, and Ecology, during all hours when the removal action is being conducted.
 - No new access roads, routes, or trails will be constructed as part of the removal action.

5.2 OVER-WATER DEMOLITION OF THE MAJORITY OF THE PIER 4 STRUCTURE

Project activities will include demolishing the majority of the Pier 4 structure. This includes the existing Pier 4 deck between Bents 92 and 144 (approximately 1,040 feet). The existing fender system, utilities, and other appurtenances will be removed and will be followed by the demolition of the existing crane beam, bull rail, and all crane appurtenances. Demolition of the pier deck, deck beams, and pile caps will then take place, followed by pile extraction, as described below in Section 5.4. Approximately 140,550 square feet of existing decking will be removed, beginning with saw cutting and removing the existing pavement and ballast. The existing asphalt thickness varies from 3 to 6 inches over approximately 1 to 3 feet of ballast. Both the ballast and asphalt will be excavated, and removed using standard construction excavation equipment. After the pavement and ballast have been removed, the concrete elements of the deck will be removed in large pieces to be broken up upland from the pier. The bulkhead and supporting batter piles will also be demolished and removed, along with the pier structure, as the pier deck demolition progresses. A portion of underground utilities will also be demolished during this phase of work. The two existing storm drainage outfalls in the dredge area will be relocated to the new dredge cut line and stabilized, as necessary, to continue functioning. Demolition will proceed according to regulatory requirements using industry standard BMPs. Debris will be disposed of according to regulatory requirements, and materials will be recycled to the extent practicable. Demolition activities will occur over approximately 100 calendar days. All of the demolition activities, excluding pile extraction as described below, will be conducted above the project-specific OHWM or in the dry at any elevation, including upland demolition activities (utilities) and over-water demolition of the deck and fender system.

5.2.1 Best Management Practices

To minimize the potential for adverse water quality impacts during the demolition of the Pier 4 structure, the following BMPs will be implemented:

- All equipment that will operate over water or below OHWM will be free of accumulated grease, oil, or mud. All leaks will be repaired prior to arriving on-site. Equipment will be inspected daily for leaks, and accumulations of grease, oil, or mud. Any identified problems will be fixed before the equipment is operated over water or below OHWM.

- An emergency spill kit will be available on-site during construction whenever work is being performed in or near the water. It will be stored in a location that facilitates its immediate deployment if needed.
- BMPs will be used to ensure no work materials or debris enter the water. Such BMPs may include, but are not limited to, floats, falsework, scaffolding, and other means as necessary to prevent debris from falling into the water.
- As a contingency item, in the event that any materials or debris do enter the water despite BMP implementation, buoyant materials dropped into the water will be picked up immediately by the Contractor. The Contractor will have a boat available and on-site during in-water activities for floating debris retrieval. Materials that sink to the bottom are to be noted and picked up immediately; however, depending on the type of item and where it falls, materials may be removed at a later date in coordination with the Port and USEPA to avoid resuspension of contaminated materials. The means and method of item retrieval is subject to the approval of the Port and USEPA.
- A containment boom will be placed around the perimeter of the construction site during demolition and pile removal activities to contain floating debris and materials in the event that materials or debris do enter the water despite BMP implementation during project activities. The captured debris will be removed upon completion each day.

5.3 NAVIGATION LIGHT PILE REMOVAL AND INSTALLATION

The existing navigation light at the south end of Pier 4 will be relocated to accommodate demolition of the pier, and, based on communications with the Puget Sound Pilots and U.S. Coast Guard, it is also necessary to relocate its companion light (pile-supported), which is located on the other side of the Blair Waterway. The Contractor is required to install temporary navigation lights, as necessary, during the removal and relocation of the lights. The new lights in their new locations will be constructed on free standing, in-water platforms, each supported on four driven steel piles, for a total of eight piles. The piles will be installed using a hydraulic vibratory hammer. The Port is proposing conducting the removal of the existing navigation light at the south end of Pier 4 (located on the pier and not in-water), as well as the companion light (pile-supported) across the waterway (located in the water below OHWM) prior to the start of the in-water work window starting on June 15, 2015. The rationale for beginning pile extraction activities prior to the in-water work window was presented in a memorandum to the USEPA in December 2014 (Floyd|Snider 2014c). A total of four 18-inch-diameter steel piles will be removed using vibratory methods.

The vibratory pile installation activities for eight piles will occur over approximately 5 calendar days and will be installed after the start of the in-water work window.

5.3.1 Best Management Practices

To minimize the potential for adverse water quality impacts during the removal and installation of steel piles for in-water platform activities, the following BMPs will be implemented:

- During steel pile removal and installation, any accumulated debris will be collected daily and disposed of at an approved upland site.
- Piles will not be placed in or adjacent to vegetated shallows, wetlands, or special aquatic sites, or within sites designated by WDFW as documented or suitable forage fish spawning areas.
- Hydraulic water jets will not be used to remove or place piles.

5.4 VIBRATORY PILE EXTRACTION

The demolition of the existing timber-pile-supported fender system will include dismantling the existing chocks and wales and removing approximately 87 14-inch-diameter creosote-treated timber piles and 22 20-inch-diameter steel pipe piles by means of a vibratory hammer or by pulling with a choke chain. This will result in the removal of approximately 141 square feet of over-water coverage from the removal of the fender piles. The demolition of the existing concrete piles will include removing approximately 1,047 16.5-inch-diameter concrete piles waterward of OHWM by means of a vibratory hammer or by pulling with a choke chain. Piling located within the dredge prism will be removed prior to the start of the dredge activities. This will result in a total removal of 1,784 square feet of over-water coverage for all piles including: concrete, creosote-treated timber, and steel pipe piles.

Pile extraction activities will be conducted below OHWM and will occur within a time period of approximately 100 calendar days. Pile extraction is proposed to occur 1 month prior to the start of the in-water work window, on June 15, 2015, to reduce the chances that a work extension would be needed to complete remedial dredging within one season and to accommodate NMFS' stated concern that the greatest effects may occur when contaminated sediments are removed. Accordingly, NMFS recommended dredging of sediments during the beginning of the in-water work window, well before the early juvenile Chinook salmon out-migrants would be present. The rationale for beginning pile extraction activities prior to the in-water work window was presented in a memorandum to the USEPA (Floyd|Snider 2014c).

5.4.1 Best Management Practices

To minimize the potential for adverse water quality impacts during the removal of the creosote and concrete piles, the following BMPs will be implemented:

- During removal of creosote-treated piles, containment booms and absorbent sausage booms (or other oil-absorbent fabric) will be placed around the perimeter of the work area to capture wood debris, oil, and other materials released into marine waters.

- The piles will be extracted in a controlled and slow manner to minimize turbidity in the water column as well as sediment disturbance.
 - The crane operator will “wake up” or vibrate the piles to break up the bond with sediment prior to extraction.
- Extraction equipment (i.e., vibratory hammer) must be kept out of the water to prevent pinching creosote-treated timber piling below the water line.
- Piling will not be broken off intentionally by twisting, bending, or other deformation, which could release creosote to the water column.
- Removed creosote-treated piles will be disposed of in a manner that precludes their further use. Piles will be cut into manageable lengths (4 feet or less) for transport and disposal in an approved upland location that meets liner and leachate standards (Chapter 173-304 of the Washington Administrative Code [WAC], Minimum Functional Standards).
- All pre-stressed concrete piles and steel pipe piles designated for demolition shall be completely removed by pulling. Jetting is not permitted.
- Existing timber piles will be completely removed by vibratory pulling. Piles that cannot be fully extracted and break during pulling shall be cut off 3 feet below mudline and the hole backfilled with clean sand. The position of each pile that breaks during pulling shall be recorded and submitted to the Port. Depending on the location of the broken pile, it may be removed at a later date in coordination with the Port and USEPA to avoid or minimize resuspension of contaminated materials. The means and method of pile retrieval is subject to approval of the Port and USEPA. Jetting and grubbing to remove the piles will not be allowed.
- Upon removal from the substrate, the pile shall be moved expeditiously from the water into a containment basin, located within a barge or on land and will be subject to the conditions of the Phase 1 Removal Action Stormwater Pollution Prevention Plan (SWPPP) and no turbid water will be released to the Blair Waterway. The pile shall not be shaken, hosed-off, stripped or scraped off, left hanging to drip, or subjected to any other action intended to clean or remove adhering material from the pile while over water.
- All accumulated debris (including cut-up piling, sediments, construction residue, and construction material from the containment basin) will be collected daily and disposed of at an approved upland site, and no treated wood will be reused.

5.5 DREDGING

Approximately 49,000 CY of TBT-contaminated sediment, as well as approximately 2,300 CY of clean riprap slope armor and approximately 9,000 CY of underlying clean suitable sediment, will be dredged by means of a mechanical standard clamshell or digging bucket dredge modified with a “top hat” on a floating derrick barge creating approximately 23,000 square feet of open water. The dredging activities will be below the OHWM and are expected to occur over approximately

140 days; 19 days for clean and suitable top of slope sediment dredging and survey and up to 126 calendar days for TBT-contaminated sediments followed by surveying, confirmational sampling, and potential sand placement, if necessary. The estimated duration for TBT-contaminated dredging includes initial required dredging and up to two additional dredge passes.

The Port's proposal to conduct the dredging of TBT-contaminated sediments beginning no earlier than August 2015, after the removal of the upslope clean material, will further reduce potential impacts to the tail end of the out-migrating juvenile salmonids.

The Phase 1 Removal Action dredge plan is presented in Figure 5.2. Representative cross sections showing the boundary between the approximately clean 9,000 CY located at the top of slope and the TBT-contaminated sediments, as well as other Phase 1 Removal Action components, are presented in Figures 5.3 through 5.5.

In order to facilitate the dredging of the approximately 9,000 CY of clean sediment, prior to dredging, the 2-foot layer of riprap armor (approximately 2,300 CY) will be removed and disposed of upland at an appropriate facility or reused by the Port for bank repairs throughout the tideflats. A small quantity (approximately 300 CY) will be used for slope stabilization in the vicinity of the electrical substation, as described in Section 3.0. The Pier 4 Phase 1 Removal Action Plan SWPPP will have conditions that no turbid water may be released to the Blair Waterway. Any excess soil and water in the upland area of the clean riprap stockpiles will be controlled by means of an appropriate combination of perimeter controls and segregation of stormwater run-on/runoff and no turbid water will be released back to the waterway. A survey will be required to confirm the design depth has been achieved prior to dredging the remaining clean sediment for open water disposal.

The design dredge depths were increased relative to the Phase 2 Project initial design prism elevations because sampling events confirmed that the extents of the TBT contamination were deeper than originally anticipated. The design dredge depths were conservatively increased further into clean material (confirmed to be clean per the April, August and November 2013 and July 2014 sampling event results) to ensure the complete removal of TBT-contaminated sediments and to minimize dredge residuals as described below:

- **Under-Pier Slope Dredge Areas.** At each sample location, the bottom of the shallowest "clean" (i.e., the TBT concentration did not exceed the TBT SL of 73 µg/kg) 2-foot sampling interval was established as the top of the subsurface material proposed to be considered clean. For example, at a location where TBT did not exceed the SL in a 4- to 6-foot bml sample interval, 6 feet bml was used as the bottom of the Phase 1 Removal Action dredge prism and the top of the subsurface material proposed to be considered clean. Several under-pier sample locations indicate that the current conceptual Phase 1 Removal Action dredge cut, using this approach, either reaches into native, or comes within approximately 1 foot of native.
- **Pier Face "Central Hot Spot."** The TBT contamination maximum depth at Sample Location A8 extends to -54.8 feet MLLW (the native interface at this location), deeper

than the design dredge prism depth of -53 feet MLLW, including the overdredge allowance. However, in the RSER it was proposed that the dredge prism depth of the central hot spot area would extend to -56 feet MLLW for removal of TBT-impacted sediments. Following finalization of the RSER and USEPA approval, a dredge residual evaluation was conducted that included the proposed multi-pass dredge approach to manage and minimize dredge residuals. As a result of this evaluation, the dredge prism depth of the central hot spot area extends an additional 1 foot deeper to -57 feet MLLW. This depth is at least 2 feet into native material at Sample Locations A8 and A17, where the deepest TBT contamination at Pier 4 was encountered at approximately -54.8 feet MLLW. This depth is also at least 2 feet below the deepest TBT contamination at Sample Locations A7 and A16 in the central hot spot. The dredge residual evaluation, associated results, and their application to the dredge approach are described in Appendix A.

- **Pier Face “Southern Hot Spot.”** The TBT contamination maximum depth at Sample Location B7 extends to -48 feet MLLW (1 foot above the native interface at this location). The concentration of TBT detected in samples collected from Sample Location B7, up to 9,300 µg/kg, is the basis of this southern area being considered a hot spot with additional dredge BMPs. In the RSER it was proposed that the dredge prism depth of the southern hot spot area would extend to -53 feet MLLW for removal of TBT-impacted sediments, based on the depth of the TBT-contaminated sediments encountered in the up slope dredge area and adjacent pier face (i.e., End of Pier and Surface Slope B). Following finalization of the RSER, a dredge residual evaluation was conducted that included the proposed multi-pass dredge approach to manage and minimize dredge residuals. As a result of this evaluation the dredge prism depth of the southern hot spot area extends an additional 1 foot to -54 feet MLLW. This depth is over 5 feet into native material at Location B7. The dredge residual evaluation, associated results, and their application to the dredge approach is described in Attachment A.2 of Appendix A.

This conservative design dredge depth approach results in the dredge depth along the pier face ranging from -54 feet MLLW at the south end of the pier, to -57 feet MLLW at the central hot spot, and to -55 feet MLLW at the remaining portions of the pier face. Under the slope, the design dredge depth to remove all TBT-contaminated sediments, per the approach outlined above, includes an 8-foot dredge cut, 9-foot dredge cut, and an 11-foot dredge cut. The design dredge depths are shown on Figure 5.2.

Dredging will be implemented in a multi-pass dredge approach, in which the majority of the TBT-contaminated dredge depth will be removed in the first pass (vertical cut), followed by a second pass that removes a thinner layer (1 to 2 feet) of contaminated sediments plus at least 2 feet of clean underlying sediment to the dredge design depth. The first pass conducted by the Contractor will likely consist of more than one lift or “bite” with the dredge bucket and will depend on the bucket size, slope conditions, and Contractor methodology. Additionally, a third pass will be conducted in the hot spot areas, as part of the required dredging, for dredge residual management. As described in Section 5.8 and in detail in Appendix A, in the pier face hot

spots and around the waterward perimeter of the dredge area, clean sand may be placed following dredging if TBT concentrations in the final post-dredge confirmational samples are greater than the DMMP SL. The post-dredge confirmational sampling approach is described in detail in Appendix A.

The dredging sequence will be conducted from the top of slope down to the toe of the slope. This sequence will be implemented for slope stability considerations, to support the natural angle of repose and avoid/minimize sloughing of contaminated sediment downslope.

An additional increment of up to 1 foot below the required dredge elevations will be payable to the contractor to account for equipment tolerance on the Phase 1 Removal Action Project; however, the maximum allowable overdredge is 2 feet below the required dredge elevation.

5.5.1 Best Management Practices

5.5.1.1 Dredging of Approximately 9,000 CY Clean Sediment

To minimize the potential for adverse water quality impacts during dredging activities within the top of slope clean 9,000 CY (and riprap removal, if appropriate), prior to the dredging of TBT-contaminated sediments, the following BMPs will be implemented:

- Clean dredging will be conducted during the WDFW-approved in-water work window for Commencement Bay (July 16 to February 14).
- BMPs in Section 5.5.1.2 related to turbidity control (excluding hot spot specific BMPs) will be employed during dredging of clean sediment and riprap removal.
- Following removal of the overlying pier structure and riprap and during the beginning of dredging, a visual inspection of the clean material to be dredged will be conducted by verifying depth and visually monitoring the dredged material on the barge to ensure there is no debris present at the surface of the dredge prism.
- If the dredging is conducted at dusk or at night, the Contractor shall ensure that sufficient light is provided for visual monitoring of the dredge prism for turbidity and visual inspection for debris or large rocks within the disposal barge.

5.5.1.2 Dredging of Approximately 49,000 CY TBT-Contaminated Sediment

To minimize the potential for adverse water quality impacts during dredging activities within the TBT-contaminated 49,000 CY, the following BMPs will be implemented:

- Dredging of TBT-contaminated sediments will occur no earlier than August 2015, which will further reduce potential impacts to the tail end of the out migrating juvenile salmonids per WDFW's recommendation.
- Dredging of contaminated sediment is restricted to occur subsequent to dredging of clean sediment to avoid residual depositing on the clean sediment surface.
- Horizontal control for dredging operations will be achieved by careful tracking of clamshell bucket positions using an electronic positioning system

- (Differential Global Positioning System [DGPS]) that provides real-time display and tracking of the horizontal position of the dredge bucket to be in compliance with the authorized dredge depths. The Port will work closely with the Contractor to achieve compliance with the designed dredge depths and boundaries of TBT-contaminated sediments and non-contaminated or clean underlying sediments.
- Dredging will be conducted from the top of slope, down along the slope at a stable grade in order to prevent undermining/sloughing of the dredge prism.
 - Due to the presence and co-location of the riprap rock armor, the Port will require the dredging Contractor to use an extra heavy bucket that has the added weight and ability to close on the rock armor. This will facilitate the bucket jaws fully closing, thereby, minimizing the chance of rock preventing the bucket from closing and minimizing turbidity and possible TBT-contaminated sediment releases to the water column.
 - The Contractor will be required to confirm the bucket is closed prior to hoisting the bucket to the water surface.
 - The digging bucket will be modified with a plastic or steel-fabricated “top hat” or lid that will effectively close off the top of the dredge bowls and minimize sediment loss as the bucket is raised through the water column.
 - If it becomes apparent that the bucket may be over-penetrating the sediments, then the bucket speed approaching sediment will be reduced (preventing sediment from becoming piled on top of the bucket then eroding during retrieval).
 - If elevated turbidity is observed at the early warning stations, the cycle time for the hoisting and lowering of the bucket will be reduced as necessary to come into compliance.
 - During dredging of the two hot spot areas (as defined in the RSER [Floyd|Snider 2014a] and approved by USEPA) a boom-supported curtain will be used to provide sediment containment around the immediate vicinity of the dredge bucket to minimize water quality impacts and residual travel distances. The curtain will also exclude fish from entering during active dredging of the hot spot.
 - Stockpiling of material below OHWM will not be allowed (i.e., each time the bucket is closed it will be brought to the surface).
 - Dredging will be done using a multiple pass dredge approach to avoid incomplete removal of contaminated sediments and to increase sediment capture and reduce residuals.
 - Dredging will be sequenced to avoid swinging the dredge bucket over "dredged-to-clean" areas and, after working down the slope, dredge higher levels of TBT contamination first (e.g., hot spot areas), as feasible.
 - The Contractor will ensure that the bucket is completely emptied of sediments over the disposal scow before re-submerging the bucket in the waterway.

- Disposal scows (with water-tight bin walls or fences) used for transporting dredged material will not be overfilled to the point where recovered sediment or any associated water overflows directly back to the waterway.
- Material will be placed into the disposal scows without splashing material out of the barge.
- A disposal scow with water-tight bin walls or fences to contain material and associated water, allowing no overflow or discharge of turbid water, will be used and all sediments and water will be contained.
- Disposal scows, flat barges, and other floating equipment shall be operated to minimize nearshore propeller-wash impacts such as suspension of nearshore sediments.
- The Port and its Contractor will conduct both interim-dredge bathymetric surveys and post-dredge bathymetric surveys to ensure that the material located within the dredge boundaries of TBT-contaminated sediments was removed to the proper, authorized extents and depths.
- Post-dredge confirmational sampling will be conducted to confirm that the removal action achieved the project objectives and completion requirements (refer to Appendix A for details), as well as to provide sufficient analytical data to determine that the underlying sediment that is within the Phase 2 Project dredge prism is suitable for either open water disposal or beneficial use in support of a separate DMMP suitability determination.

5.6 TRANSLOADING

TBT-contaminated dredged material will be moved by water-tight scows to the transload site at APM Terminals (the Transload Site) and transferred to shore for processing (Figure 5.6). APM Terminals was chosen as the preferred transload site because, in addition to having the necessary criteria for a suitable transload and dewatering site, it meets the two criteria that are required to consider it part of the CERCLA Phase 1 Removal Action site: (1) it is Port-owned, and (2) it is contiguous with the Phase 1 Removal Action site footprint. Because it is part of the Phase 1 Removal Action site, the transloading and dewatering activities are exempt from state and local permits.

APM Terminals is located on the west site of the Sitcum Waterway, with the western edge adjacent to the Milwaukee Waterway Habitat Area. Approximately 7 acres of APM Terminal's facility will be used as the Transload Site to process, dewater, and stockpile the contaminated dredged material for upland disposal. As shown on Figure 5.7, there are five catch basins; four drain to the east and one drains to the south. All catch basins will be plugged prior to site use to ensure dewatering process water and stormwater falling on the Transload Site do not enter APM Terminal's existing stormwater collection system. The Transload Site is fully paved with asphalt that is 4 inches thick. Any significant cracks will be sealed prior to starting the transload and dewatering activities. Existing 4-inch deck drains will also be plugged to prevent all process water from entering the Sitcum Waterway during transloading activities. Access to the Transload

Site will be secure and will run through APM Terminals with cooperation with the terminal operator. Transportation Worker Identification Card (TWIC) credentials will be required for unescorted access to the Transload Site. Water and power will be available to the Contractor during transloading activities.

The Contractor will be required to protect the existing fender system along the APM Terminal pier, as it is designed for berthing container ships, not barges. This may require installation of up to 10 steel piles along the pier face for barge berthing. If pile installation is necessary, it would occur after the start of the in-water work window, and BMPs identified under Section 5.3 would apply. If piles are installed, they will be removed prior to the end of the in-water work window and BMPs identified under Section 5.4 would apply.

Once transferred to shore from the disposal scow, sediments will be stockpiled within a confined area and dewatered. Transfer, stockpile, and load-out areas will be designed to collect leachate (from dredging and rainwater) for treatment prior to disposal, as discussed in Section 5.7 below. The Contractor selected to perform the construction activities will be subject to the requirements and procedures specified in the RAWP and the construction bid documents regarding transloading.

All dredged material placed at the Transload Site must pass the paint filter test before being loaded and trucked off-site. The stockpiles shall be built on an engineered drainage system that will allow the dredged material to have a drying agent mixed in or that will allow for passive dewatering. All drained water shall be collected in an adjacent settling basin and treated in a contractor-designed water treatment facility. Water quality monitoring will be performed per the WQMPP and water will be discharged into the waterway. Once sufficiently dried and/or stabilized for trucking, sediments will be loaded into road-trucks for off-site disposal at the LRI Landfill at Graham, Washington.

5.6.1 Best Management Practices

To minimize the potential for adverse water quality impacts during transloading activities, the following BMPs will be implemented.

5.6.1.1 Contractor Submittal

The Contractor shall prepare a Transload, Transport, and Disposal (TTD) Contractors Work Plan for review and approval by the Agencies at least 60 days prior to dredging, which will include (but not be limited to) the BMPs indicated below. The TTD shall include a Stormwater Pollution Prevention Plan (SWPPP) for operation of the Transload Site that shall meet National Pollutant Discharge Elimination System (NPDES) substantive requirements. Because this work is being conducted as a Time Critical Removal Action under USEPA's authority, an NPDES permit will not be required as long as substantive requirements for NPDES are met. Use of the TDD may not commence until approved by the Agencies.

BMPs Related to Barge Transit

- Barges transiting from the Phase 1 dredge area to the Transload Site shall contain all material, water or sediment, during transit. Dewatering from the barge into the waterway is not allowed.
- Dredged material shall not be piled above barge sidewalls at any time during transit.

BMPs Related to Unloading of Sediment from the Barges at the Transload Site

- There shall be no passive dewatering from the barge into the waterway.
- Wharf decking and all surfaces that can come in contact with dredged sediment and associated water shall be made of solid (no slats), impermeable materials. The Contractor shall be prepared to block and pump the wharf area during transloading if rainwater accumulates.
- Sheeting or equivalent impermeable lining shall be placed under the travel area of the bucket to capture any spills. In the event there are any spills outside of the area covered by the sheet, the spilled material shall be cleaned up immediately.
- Dockside sediment control (e.g., sweeper truck, shoveling, sweeping, wash down) shall occur as often as necessary to avoid the tracking of sediment by vehicles and personnel and to generally maintain a clean site, and shall include the dock, transload area, and the haul routes.
- Transfer of dredged material shall occur in a fashion that minimizes splash and splatter of the material.
- There shall be no path for material to fall into the water during off-loading operations. Spill aprons or other containment devices shall be used to prevent the release of spilled material into the water between the barge and the dock.
- Spill aprons shall be impermeable, uninterrupted, and structurally adequate to catch any falling material, including rain water, and hold or deflect it back into a contained area, either on shore or on the barge.
 - The spill apron shall be wide enough that caught material or water will not fall off the sides.
 - Material shall not be allowed to accumulate on the spill apron.
 - The spill apron must be able to provide protection throughout the full tidal range.
- The Transload Site must have the ability to keep the barge tied up close to the dock during tidal fluctuations.

BMPs Related to Stormwater Management at the Transload Site

- The Contractor shall prepare a SWPPP for the Transload Site as a component of the TTD that describes operational and structural source control BMPs related to barge material transloading. The SWPPP will be available for review by all involved or

- interested agencies. The SWPPP shall ensure that the transload operations are in substantive compliance with NPDES requirements.
- The SWPPP shall describe the routing and ultimate disposal of any water from the dredged material, all stormwater collected within the dredged material handling area, any water that is used for wash-down of trucks and equipment, and any water that may come in contact with the dredged material or dredged material handling equipment. All water management at the Transload Site shall meet the requirements of both the approved SWPPP and the WQMPP. All stormwater that comes into contact with dredged material or dredged material handling equipment shall be treated in accordance with the WQMPP. All stormwater falling into or entering the transload area shall be treated in accordance with the WQMPP.
 - The SWPPP shall discuss the design storm criteria and shall also discuss the contingency for overflows in excess of the design storm and controls to minimize stormwater contributing to the sediment dewatering process.

BMPs Related to Containment and Treatment of Water Generated during Transloading

- Dredged material handling and dewatering shall take place in an exclusion zone that prevents dredged water and sediment from entering the site's stormwater system. The use of the existing catch basins as drainage sumps is allowed as long as all piping into the catch basins is plugged and the catch basins are watertight. Dredged water and sediment is not allowed to enter stormwater piping.
- The dredged water treatment system shall have a discharge system that is completely separate from the site's stormwater system.
- After completion of the transload operation, the surrounding work area shall be washed and the wash water captured and treated via the dredge water treatment system.

BMPs Related to Transport of Off-Loaded Material

- Dredged material shall be sufficiently dewatered to pass the LRI Landfill paint filter test prior to transporting from the Transload Site.
- All truck loads shall be water-tight and covered to prevent loss of material during transport.
- Loading of the trucks shall take place within an exclusion zone, which will be established to contain any spilled material that may occur while loading. All loads will be inspected to ensure that no dredged materials are on the outside of the truck, and that the loads are covered and not leaking during transit.
- A wheel wash(s) shall be installed immediately adjacent to the outbound gate of the transload area. If necessary, the exterior of the trucks shall be swept of excess material prior to leaving the loading area. Any spilled dredged material and water generated from cleaning the exterior of the trucks will be treated on-site.

- Loading practices (e.g., partially loading to provide freeboard; loading near centerline of truck bed) shall be employed to prevent spillage.

BMPs Related to Stockpiling Material On-Site

- It is anticipated that handling and dewatering of dredged material may require the use of short-term surge-piles and/or long-term stockpiles. If material piles must be used, then the following BMPs shall be addressed:
 - All material piles shall be located within the confines of the contained transload area to allow water to drain to the treatment system.
 - The Contractor shall visually monitor all material piles for fugitive dust and will be required to employ dust control measures if necessary.
 - All stockpiles shall be located on an impervious surface. All pavement cracks in pile areas and drainage areas shall be sealed prior to placing material.
 - Stockpile areas will be inspected daily and after high precipitation events.

BMPs Related to Spills of Dredged Material into the Water

- USEPA shall be notified of the incident immediately. A memorandum shall be prepared and submitted to the Agencies describing the incident and providing specifics on the material released, possible causes, and actions taken. The location and amount of any sediment that enters the waterway shall be documented. If possible, the spilled material shall be retrieved from the waterway in the most expeditious manner possible.

5.7 DEWATERING TREATMENT SYSTEM AND DREDGE RETURN WATER

The sediment arriving at the Transload Site will contain an approximate 1:1 ratio of sediment and water, such that approximately 8 to 10 million gallons of water will need to be dewatered and treated. TBT-contaminated water will be generated from water pumped from a decant barge at the dredge site and from water collected from the upland sediment dewatering staging area at the Transload Site. Water from both sources will be treated to remove TBT to concentrations less than applicable water quality criteria prior to the points of compliance discussed in the WQMPP (Appendix B).

Approximately 150,000 to 300,000 gallons per day of water will need to be treated, which will require a treatment system capable of treatment flow rates in the 300- to 600-gallons per minute (gpm) range. The removal of dissolved TBT from the water will require a treatment train including: primary screening and settling to remove large particles; coagulation and settling; mixed-media filtration to remove total suspended solids (TSS), turbidity, and adsorbed TBT; and, finally, GAC as a final polishing step to remove dissolved TBT. The final treatment train will be customized by the Contractor, but it must be designed in accordance with the RAWP and the bid specifications. For more detailed information on the evaluation of treatment and the recommended treatment train, refer to Appendix C.

Compliance parameter monitoring during dredge return water discharge will include turbidity and chemical monitoring for TBT. Samples will be collected from the return water prior to discharge to the waterway. There are two levels of monitoring that will be conducted: Tier 1 Intensive and Tier 2 Routine, which are described in Section 6.0 of Appendix B.

5.8 POTENTIAL POST-DREDGE SAND PLACEMENT

Following completion of dredging, it will be determined based on post-dredge confirmational sampling results whether an additional dredge pass is needed in the hot spot areas or if placement of clean material (i.e., clean sand) for dredge residuals management is needed, as described in Appendix A. Sand may also be placed along the waterward perimeter of the dredge prism. If needed, a layer approximately 1 foot thick would be placed in thin lifts. The volume of sand material to be placed would be between 300 and 600 CY in the central hot spot and between 50 and 100 CY in the southern hot spot; the volume of sand to be placed along the waterward perimeter of the dredge prism would depend on the affected area. The sand layer would be below the final elevation for the Phase 2 Project, or outside of the planned dredge prism, and not be affected by Phase 2 dredging. All sand placement would be completed within the 2015 to 2016 in-water work window.

Following sand placement, the final surface elevations will be verified by bathymetric survey. Water quality monitoring will be conducted during material placement to ensure that water quality is not impacted at the point of compliance, as described in Appendix B. Material placement will be conducted following BMPs described in Section 5.8.1.

5.8.1 Best Management Practices

Clean sand material will be provided from a source location that meets the chemical and physical requirements of the bid specifications.

During fill placement activities, the following BMPs will be implemented to minimize impacts to the waterway:

- Materials will meet project specifications regarding grain size and fines content to minimize the potential for elevated turbidity in receiving waters during placement.
- Material will be placed by controlled release from a clamshell bucket. Materials will be uniformly discharged as a stream of material, as opposed to being abruptly discharged, in order to provide for uniform bottom coverage and minimize impacts to the receiving surface.
- Material will be placed from less than 10 feet above the mudline depth to limit sediment disturbance and suspension.

5.9 CONCRETE TEST PILE PROGRAM

Following completion of the pier demolition and dredging of the TBT-contaminated sediments, the site will be rebuilt during Phase 2 of the project (which includes reconfiguration of the pier). To facilitate this site restoration, the Port plans to perform a concrete test pile program as part

of the Phase 1 Removal Action. As this work is being conducted during the Time Critical Removal Action, it will be done under USEPA oversight. The intent of the concrete test pile program is to confirm design assumptions made about installation and structural capacity of the concrete piles that will be installed to support the proposed reconfigured pier in Phase 2. The program will consist of installing four 24-inch-diameter octagonal concrete piles along the length of the Pier 4 slope and will record data associated with the amount of energy required to drive each pile. The piles will be driven using an impact hammer and will be instrumented to collect the necessary data. The concrete test pile program will be conducted below the project-specific OHWM and will occur over a period of approximately 12 days and will occur within the 2015 to 2016 in-water work window. Pile installation may occur concurrent with dredging; however, piles must be installed and removed only in areas where contaminated sediments have been completely removed and confirmational sampling has been completed. All test piles will be extracted and properly disposed of upon completion of testing.

5.9.1 Best Management Practices

To minimize the potential for adverse water quality impacts during the installation and removal of the concrete test piles, the following BMPs will be implemented:

- Piles must be installed and removed only in areas where contaminated sediments have been completely removed and confirmational sampling has been completed.
- During concrete pile installation and removal, any accumulated debris will be collected daily and disposed of at an approved upland site.
- Piles will not be placed in or adjacent to vegetated shallows, wetlands, or special aquatic sites, or within sites designated by WDFW as documented or suitable forage fish spawning areas.
- A wooden block will be placed on top of the pile during all pile driving to protect the pile and attenuate underwater noise.
- Hydraulic water jets will not be used to install or remove piles.

6.0 Health and Safety

The Contractor for the Phase 1 Removal Action has not yet been identified. However, prior to starting construction, the selected Contractor will submit a HASP that ensures the protection of the public health and safety during performance of on-site work for USEPA comment and approval. The contractor HASP will be prepared in accordance with USEPA's Standard Operating Safety Procedures and will comply with all currently applicable Occupational Safety and Health Administration (OSHA) regulations.

A separate HASP to be implemented during post-dredge confirmational sampling is presented as an attachment to the Post-Dredge Confirmational Sampling Plan provided in Appendix A.

In the event any action or occurrence during the Phase 1 Removal Action causes or threatens a release of waste material from the site that constitutes an emergency situation or may present an immediate threat to public health or welfare or the environment, the Contractor will immediately take action according to the provisions of the HASP and notify the USEPA OSC. The Port will also submit a written report to USEPA within 7 days after a release, describing the events that occurred and the measures taken or to be taken to mitigate any release or endangerment caused or threatened by the release and to prevent the reoccurrence of such a release.

7.0 Access to Removal Action Area

The Pier 4 project will occur at two active container terminals; Husky Container Terminal and APM Terminals. The Pier 4 dredge site located at Husky Container Terminal will have a gated entrance secured by the Contractor. The Transload Site located at APM Terminals has restricted access requiring TWIC credentials. The Contractor will ensure that workers have the necessary credentials for access to the Transload Site. As Federal Government authorities, the USEPA OSC and other USEPA personnel are not required to present TWIC credentials for access to the project; therefore, the Port will coordinate with the Contractor and terminal security to ensure that USEPA personnel have access to the project area during construction.

In addition to USEPA personnel, upon advance notice, the Port will provide access to the construction site for representatives of USEPA, the City of Tacoma, WDFW, USACE, the Services, the Puyallup Tribe of Indians, and Ecology, during all hours when the proposed action is being conducted.

USEPA representatives may enter the project area to monitor work, verify data, conduct investigations, obtain samples, assess compliance with the RAWP, including QA/quality control procedures and/or the need for additional response actions, or inspect documents maintained by the Port or the Contractor.

8.0 Project Water Quality Monitoring and Confirmational Sampling

8.1 WATER QUALITY MONITORING

Water quality monitoring will be performed during construction and during discharge of dredge return water to ensure compliance with Section 401 of the Clean Water Act and Washington State Water Quality Standards (WAC 173-201A). The WQMPP, included as Appendix B, describes water treatment discharge performance requirements, and applicable water quality criteria and compliance monitoring locations, as well as contingency response and notification procedures in the event a water quality criterion is exceeded during removal of the pier structure, vibratory pile extraction, installation of the light piles, and dredging.

The WQMPP also provides detailed information on the points of compliance and the water quality monitoring protocol during dredge return water processing and discharge. A Dredge Return Water Technical Memorandum describing the return water treatment process is included as Appendix C. The project Contractor selected to perform the construction activities will be subject to the requirements and procedures specified in these plans, as well as the contract specifications and the USEPA 401 Water Quality Memorandum, as appropriate.

8.2 POST-DREDGE CONFIRMATIONAL AND PERIMETER SAMPLING

Confirmational sampling will be conducted following the completion of dredging to confirm that the removal action achieved the project objectives and completion requirements, as well as confirm the suitability of the underlying cutback material to be dredged under Phase 2 for open water disposal or beneficial use. Post-dredge perimeter sediment sampling and chemical analysis of TBT will also be conducted waterward and outside of the dredge footprint to assess dredge residuals and associated TBT concentrations resulting from dredge operations and confirm that no additional remedial actions are necessary. A Post-Dredge Confirmational Sampling Plan describing this sampling is included as Appendix A.

9.0 Project Schedule and Post-Construction Reporting

9.1 SCHEDULE

Work will be sequenced for construction efficiency, and to restrict the removal of the TBT-contaminated sediments (dredging) to later in the in-water work window. Dredging will begin with removal of clean sediment located on the top of the slope, above the TBT-contaminated sediments, and will begin after the start of the in-water work window on July 16, 2015. The project timeline described below is based on the project and USEPA objective of conducting a Time Critical Removal Action and timely removal of the TBT-contaminated sediments, while minimizing impacts to the environment. The construction starting dates provided in the RAWP are based on the current design schedule; however, the Contractor will develop a detailed construction schedule for project activities within the required work windows, which include pile extraction starting after June 15, 2015 and TBT-contaminated dredging starting after August 1, 2015.

The following timeline shows the currently estimated start date and the approximate period of calendar days during which each project element will be completed, without considering construction sequencing:

- Mobilization and staging: early April 2015; 30 days
- Demolition of the majority of the existing Pier 4 structure (deck demolition, including bulkhead and utilities): early May 2015; 100 days
- Vibratory extraction of piles (concrete, creosote-treated timber, and steel): mid-June 2015; 100 days
- Installation of navigation lights and potential pile installation at the Transload Site (if necessary): mid-July 2015; 75 days
- Clean riprap removal and disposal: early September; 14 days
- Dredging of clean top of slope material and survey: late September 2015; 19 days
- Dredging of TBT-contaminated sediments: mid-October 2015; 126 days³
- Concrete test pile program: early January 2016; 12 days
- Demobilization: mid-February 2016; 30 days

Management and the treatment of dredge water, as well as transloading and upland disposal of dredged material, will occur through the duration of dredging. The project is anticipated to be completed by mid-February 2016; however, off-site dewatering and treatment may extend beyond this anticipated completion. The conservation measures or BMPs to be implemented

³ This duration includes survey and confirmational sampling, followed by additional dredge passes (where necessary), surveying, confirmational sampling, and potential sand placement, if necessary.

during water treatment and transloading are described in detail in Section 5.0 and will be followed for the duration of these activities.

9.2 REPORTING

Prior to substantial completion of the Phase 1 Removal Action, and upon review and approval of post-dredge confirmational sampling results, USEPA will issue a letter stating dredging is complete to USEPA's satisfaction. Transloading of dredged sediments, dewatering, and off-site disposal of material will continue until completion. All aspects of the Phase 1 Removal Action will be documented in the Time Critical Removal Action Report, as described below.

To assure continuation of the construction project and avoid delay, USEPA will determine whether all work has been fully performed in accordance with the RAWP after review of the Time Critical Removal Action Report, with the exception of any continuing obligations required by the second AOC.

The Phase 1 Removal Action will be deemed complete when all work activities described in Sections 3.0 and 5.0 of this RAWP are completed, including water quality monitoring and dredged material disposal, and confirmational sampling. Within 90 days following completion of the Phase 1 Removal Action, a draft Time Critical Removal Action Report summarizing the work performed will be prepared and submitted to USEPA for review and approval in accordance with the project deliverables and schedule agreed to by USEPA. A final Time Critical Removal Action Report will be submitted to USEPA within 30 days of receiving comments on the draft report.

The Time Critical Removal Action Report documents and confirms the adequate performance of the removal action. It will be based on information and data available at the time the report is submitted to USEPA. The report will include the following:

- Description of removal activities undertaken.
- Description of activities undertaken to confirm that the removal action meets cleanup criteria identified in the RSER and the USEPA Action Memorandum.
- Locations, laboratory reports, and summary of results of confirmational sample collection and analysis.
- Summary of the water quality monitoring conducted during the removal action.
- QA review of analytical data associated with post-dredge confirmational sampling.
- Figures depicting the final post-removal action survey and the extent of the removal action that may be shown in future reports, including location of piling cut off below mudline and potential sand placement, if any.
- Documentation of dredged material waste disposal.
- A certification signed by a responsible Port official regarding the accuracy and completeness of the information presented in the report.

Additionally, monthly written project reports will be prepared and submitted to USEPA every 30th day after the date of receipt of USEPA's approval of this RAWP until issuance of Notice of Completion of Work on the first day of each month during the project period, unless otherwise directed in writing by the OSC. The progress reports will summarize the actions taken on the project and identify any anticipated modifications to the project work or schedule. The Port will also coordinate monthly meetings and/or teleconferences with USEPA to discuss the status of work, and stakeholder briefings as appropriate with USEPA and project stakeholders including, but not necessarily limited to, Ecology and/or the Puyallup Tribe of Indians. The USEPA and the Port will review and confer on comments to be addressed in the Time Critical Removal Action Report.

10.0 References

- Floyd|Snider. 2014a. *Pier 4 Phase 1 Removal Action Project Removal Site Evaluation Report*. Prepared for Port of Tacoma. 25 September.
- _____. 2014b. *Pier 4 Phase 1 Removal Action Report Phase 1 Project Description Document*. Prepared for Port of Tacoma. 12 September.
- _____. 2014c. *Memorandum Re: Rationale Supporting Pile Extraction Prior to July 15, 2015 In-water Work Window*. 15 December.
- Hart Crowser & Associates (Hart Crowser). 1974. *Geology of the Port of Tacoma*.
- Hoffman, E. 1998. *Tributyltin Analysis: Clarification of Interstitial Water Extraction and Analysis Methods- Interim*. Final DMMP Technical Paper SMS Technical Information Memorandum Prepared by USEPA for the DMMP Agencies. 22 December.
- U.S. Army Corps of Engineers (USACE). 2014. *Dredged Material Evaluation and Disposal Procedures (User's Manual)*. Dredged Material Management Program: U.S. Army Corps of Engineers, Seattle District; U.S. Environmental Protection Agency, Region 10; Washington State Department of Natural Resources; Washington State Department of Ecology. December.

**Pier 4 Phase 1 Removal
Action Project**

Removal Action Work Plan

Table

Table 4.1
Applicable or Relevant and Appropriate Requirements

Topic	Standard or Requirement	Regulatory Citation	Notes
Sediment Quality Standards	DMMP screening levels; project screening and action levels	DMMP User's Manual (July 2013)	The proposed action will remove or contain materials that have the potential to further degrade sediment quality. Dredging will remove sediments confirmed to have elevated TBT concentrations that will not exceed the Dredged Material Management Program (DMMP) TBT Screening Levels or proposed Action Levels. Post-Dredge Confirmational sampling of the post-dredge sediment surface will be conducted to determine compliance with the project screening and action levels.
Surface Water Quality	Surface water quality standards	Ambient Water Quality Criteria (Section 304(a) of Clean Water Act) and Surface Water Quality Standards (RCW 90-48; WAC 173-201A)	The proposed action will protect surface water quality by minimizing the potential release of TBT to the Blair Waterway. To protect water quality, the work area will be surrounded by an absorbent boom and dredging within the hot spot areas will include the use of a floating boom-supported curtain. Surface water quality monitoring will be conducted during project activities, including the discharge of dredge return water, to ensure compliance with applicable standards per the Water Quality Monitoring and Protection Plan (WQMPP; Appendix B).
Solid Waste Disposal	Requirements for solid waste handling and disposal	Solid Waste Disposal Act (42 USC 215103259-6901-6991; 40 CFR 257-258)	Waste material (dredged sediment, extracted piles, bulkhead materials, anthropogenic debris) removed from the site will be managed using an appropriately permitted, off-site disposal facility.
In-Water Work	Discharge of dredge material in navigable waters	Clean Water Act (33 USC 401 et seq.; 33 USC 141; 33 USC 1251-1316; 40 CFR 230, 231, 404; 33 CFR 320-330) River and Harbors Act (33 USC 401 et seq.) and Hydraulic Code Rules (RCW 75.20; WAC 220-110)	The proposed action includes dredging, waste removal, and potentially backfill placement within the site. USEPA has consulted with local, state, and federal agencies. Project work practices and BMPs address ARAR substantive requirements, including use of clean backfill materials, minimizing water quality and fisheries impacts by using appropriate equipment, hot spot dredging within a floating boom supported curtain,, implementing numerous project BMPs, and conducting the TBT contaminated dredging within the Commencement Bay allowable in-water work window to avoid potential impacts to fisheries resources. Refer to Section 5.0 of the RAWP for additional BMPs.
In-Water Work	Navigable waters	Obstruction of Navigation and Navigable Waters (33 USC 401 et seq.; Rivers and Harbors Act, Section 10; 33 CFR Parts 320 to 322)	This act prohibits unauthorized activities that obstruct or alter a navigable waterway. Section 10 applies to all structures or work below the mean high water mark of navigable tidal waters and the ordinary high water mark of navigable fresh waters. USACE permits are needed for the alteration or the modification of the course, condition, location, or capacity of a navigable water of the United States. The remedial action will not be conducted within the navigation channel. Therefore, no alteration of the navigation channel elevations will occur as part of this remedial action.
Shorelines and Critical Areas	Construction and development	Shoreline Management Act (RCW 90.58; WAC 173-16); City of Tacoma's Shoreline Master Program (TSMP), as put forth in Tacoma Municipal Code (TMC) Chapter 13.10 Shoreline Management	The proposed action is consistent with the regulation, because it will minimize potential risks to human health and the environment, and further protect sediment and surface water quality within the Blair Waterway by removing sediments with elevated TBT concentrations. The remedial action is conducted waterward and below the ordinary high water mark. Therefore, no disturbance of shoreline vegetation or habitat will occur. Protection of aquatic areas is addressed through the use of appropriate work practices and BMPs.
Habitat for Fish, Plants or Birds	Evaluate and mitigate habitat impacts	Clean Water Act (Section 404(b)(1); U.S. Fish and Wildlife Mitigation Policy (44 CFR 7644); U.S. Fish and Wildlife Coordination Act (16 USC 661 et seq.) Migratory Bird Treaty Act (16 USC 703-712)	The proposed action is consistent with the regulation, because it will minimize potential risks to fish and wildlife habitat from potential releases of site-associated contaminated materials. BMPs described in this RAWP will be followed, including conducting TBT contaminated dredging within the Commencement Bay allowable in-water work window (refer to Section 5.0 of the RAWP).
Endangered Species and Critical Habitat for Endangered Species	Conserve endangered or threatened species	Endangered Species Act (16 USC 1531 et seq.; 50 CFR 200, 402); Magnuson-Stevens Fishery Conservation and Management Act (16 USC 1801-1884).	USEPA has consulted with the U.S. Fish and Wildlife Service and with the National Marine Fisheries Service. The proposed action incorporates measures to prevent potential impacts to endangered species during construction and incorporating measures to protect water quality (refer to Section 5.0 of the RAWP).
Worker Safety	Employee health and safety regulations	Health and Safety for Hazardous Waste Operations and Emergency Response (WAC 296-62; and Health and Safety 29 CFR 1901.120); Occupational Safety and Health Act (OSHA; 29 USC 653, 655, 657); Occupational Safety and Health Standards (29 CFR 1910); Washington Industrial Safety and Health Act (WISHA; RCW 49.17); Washington Industrial Safety and Health Regulations (WAC 296-62, WAC 296-155, WAC 296-800)	Includes employee health and safety regulations for construction activities and general construction standards, as well as regulations for fire protection, materials handling, hazardous materials, personal protective equipment, and general environmental controls. Hazardous waste site work requires employees training prior to participation in site activities, medical monitoring, monitoring to protect employees from excessive exposure to hazardous substances, and decontamination of personnel and equipment. Any cleanup work will require compliance with OSHA and WISHA.

Abbreviations:

ARAR	Applicable or relevant and appropriate requirements	RAWP	Removal Action Work Plan	USEPA	United States Environmental Protection Agency
BMP	Best management practice	RCW	Revised Code of Washington	WAC	Washington Administrative Code
CFR	Code of Federal Regulations	USACE	United States Army Corps of Engineers	WDNR	Washington Department of Natural Resources
OMMP	Operations, Maintenance, and Monitoring Plan	USC	U.S. Code		

**Pier 4 Phase 1 Removal
Action Project**

Removal Action Work Plan

Figures

Note:
Orthoimagery provided by Esri, 2013.

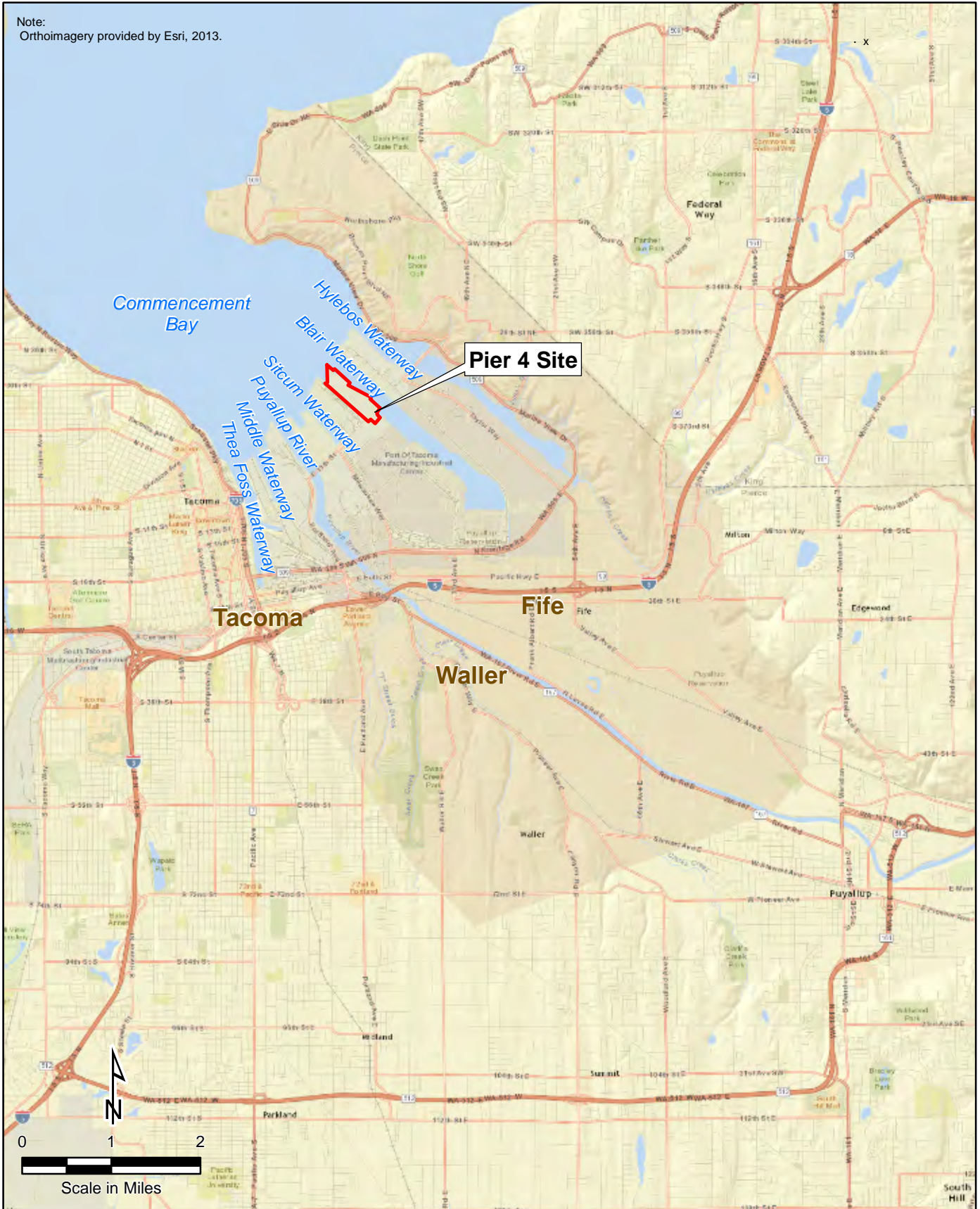

**Removal Action Work Plan
Pier 4 Phase 1
Removal Action Project
Tacoma, Washington**

**Figure 1.1
Site Vicinity Map**



Notes:
 • Pier 3 and Pier 4 locations based on KPFF data.
 • Background aerial imagery provided by Esri, August 1, 2011.



FLOYD | SNIDER
 strategy • science • engineering

**Removal Action Work Plan
 Pier 4 Phase 1 Removal Action Project
 Tacoma, Washington**

**Figure 1.2
 Location Map of Piers 3 and 4
 and Blair Waterway**

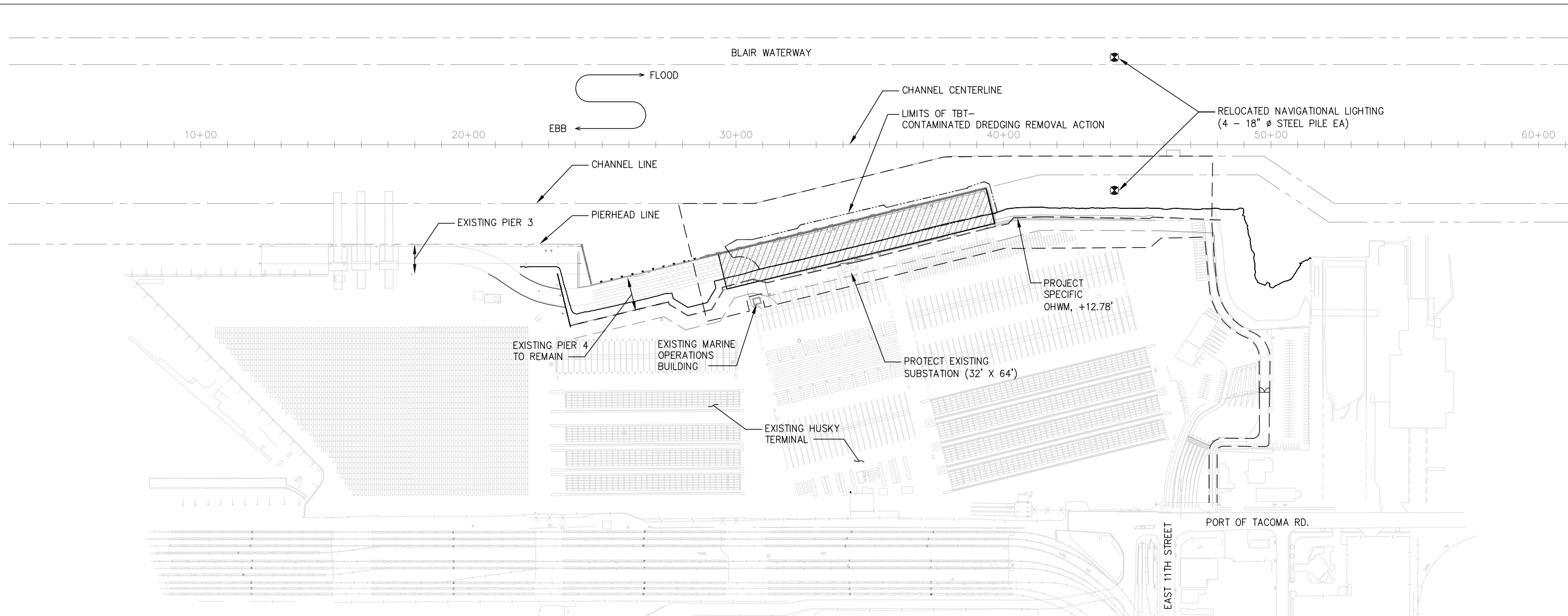
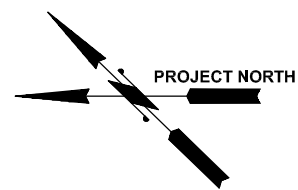

FIGURE 5.1 - PHASE 1 SITE AND DEMOLITION PLAN

SCALE: 1"=200'

LEGEND

- PROJECT WORK LIMITS
- - - - - LIMITS OF TBT - CONTAMINATED DREDGING REMOVAL ACTION
- EXISTING PIER 4 DEMOLITION (140,550 SQ FT)



kpff Consulting Engineers

101 Stewart Street, Suite 400
 Seattle, Washington 98101
 (206) 382-0600 Fax (206) 382-0500

REMOVAL ACTION WORK PLAN
 PIER 4 PHASE 1 REMOVAL ACTION PROJECT
 TACOMA, WASHINGTON

DATE: JANUARY 2015

SCALE: 1" = 200'-0"

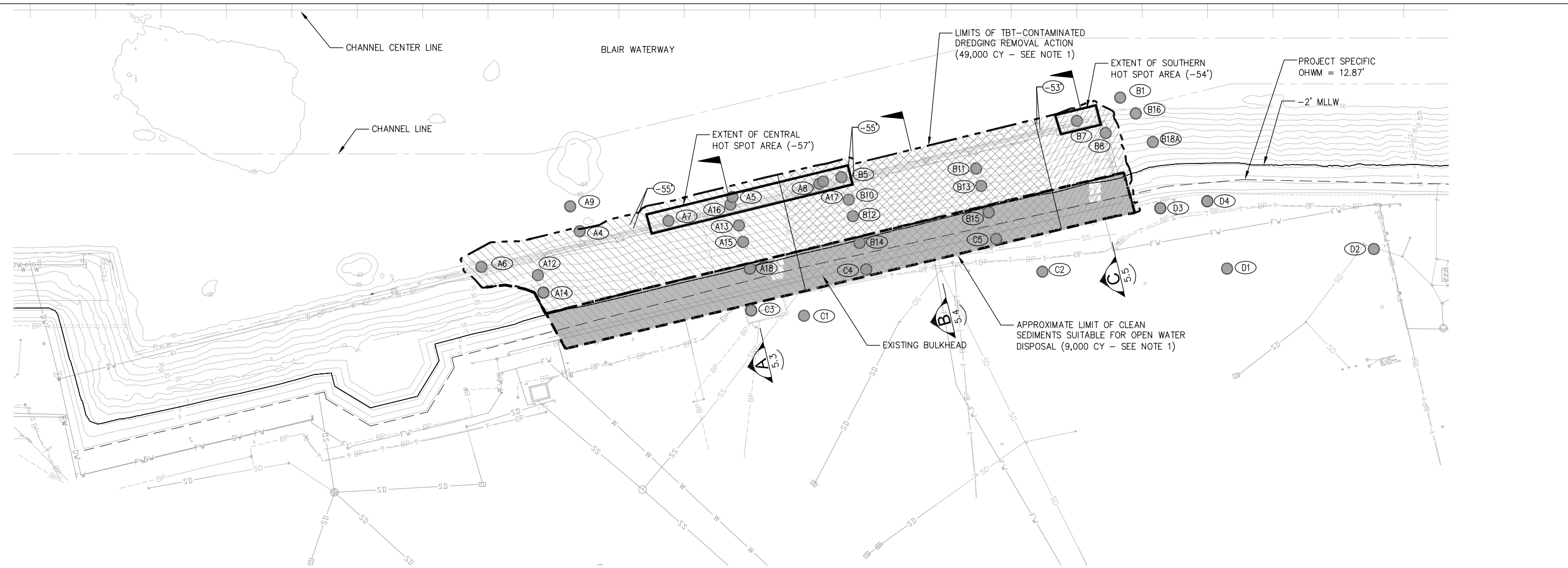

FIGURE 5.2 - PHASE 1 DREDGE PLAN

SCALE: 1"=150'

LEGEND

- EXISTING CONTOUR
- (-51') TOE OF DREDGE, SEE NOTE 2
- (XX) SAMPLE NUMBER
- SAMPLE LOCATION
- [Hatched Box] DREDGE CONTAMINATED SEDIMENT AND ROCK ALONG DEMOLISHED PIER FACE AND UPPER 9FT OF SLOPE, SEE NOTE 2
- [Cross-hatched Box] DREDGE CONTAMINATED SEDIMENT AND ROCK ALONG DEMOLISHED PIER FACE AND UPPER 11FT OF SLOPE, SEE NOTE 2
- [Diagonal-hatched Box] DREDGE CONTAMINATED SEDIMENT AND ROCK ALONG DEMOLISHED PIER FACE AND UPPER 8FT OF SLOPE, SEE NOTE 2
- [A in Triangle] CROSS SECTION LOCATION

NOTE

1. VOLUME IS APPROXIMATE AND INCLUDES THE 1-FOOT OVERDREDGE ALLOWANCE.
2. DREDGE DEPTHS DO NOT INCLUDE THE 1-FOOT OVERDREDGE ALLOWANCE

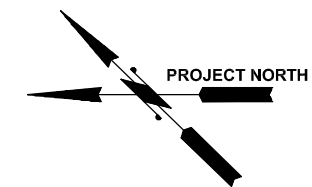

kpff Consulting Engineers

101 Stewart Street, Suite 400
 Seattle, Washington 98101
 (206) 382-0600 Fax (206) 382-0500

REMOVAL ACTION WORK PLAN
 PIER 4 PHASE 1 REMOVAL ACTION PROJECT
 TACOMA, WASHINGTON

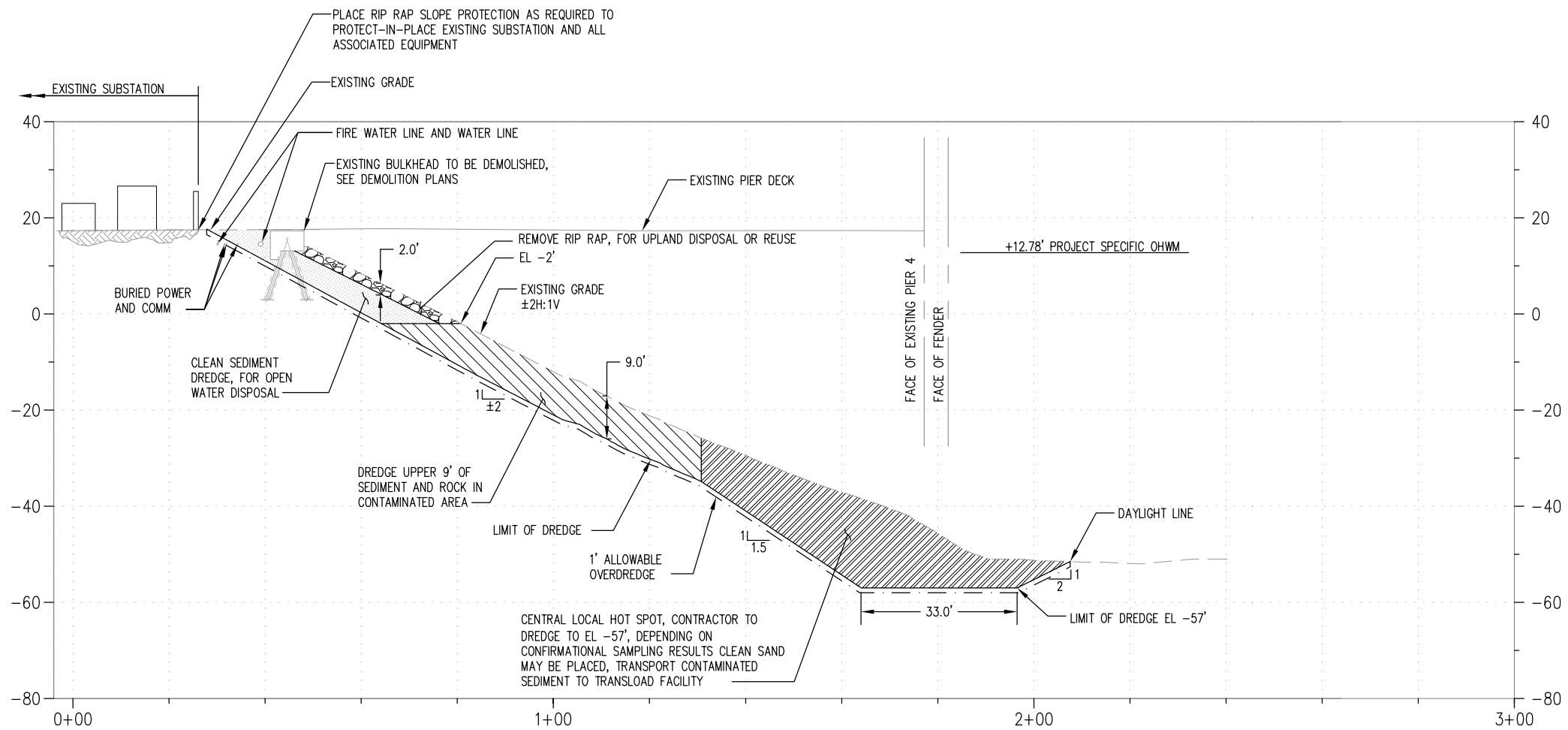

DATE: JANUARY 2015

SCALE: 1" = 150'-0"



A **FIGURE 5.3 DREDGE SECTION**
 FIG 5.2 SCALE: 1"=30'

LEGEND

-  DREDGE CONTAMINATED SEDIMENT AND ROCK ALONG DEMOLISHED PIER FACE AND UPPER 9FT OF SLOPE
-  DREDGE CLEAN SEDIMENT AND ROCK TO SAME DEPTH AS ADJACENT CONTAMINATED SEDIMENT AND ROCK, AND AT 2H:1V SLOPE UP TO EXISTING GRADE. DEPTH VARIES 8 FT TO 11 FT
-  CENTRAL LOCAL HOT SPOT

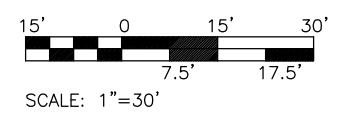

kpff Consulting Engineers

101 Stewart Street, Suite 400
 Seattle, Washington 98101
 (206) 382-0600 Fax (206) 382-0500

REMOVAL ACTION WORK PLAN
 PIER 4 PHASE 1 REMOVAL ACTION PROJECT
 TACOMA, WASHINGTON

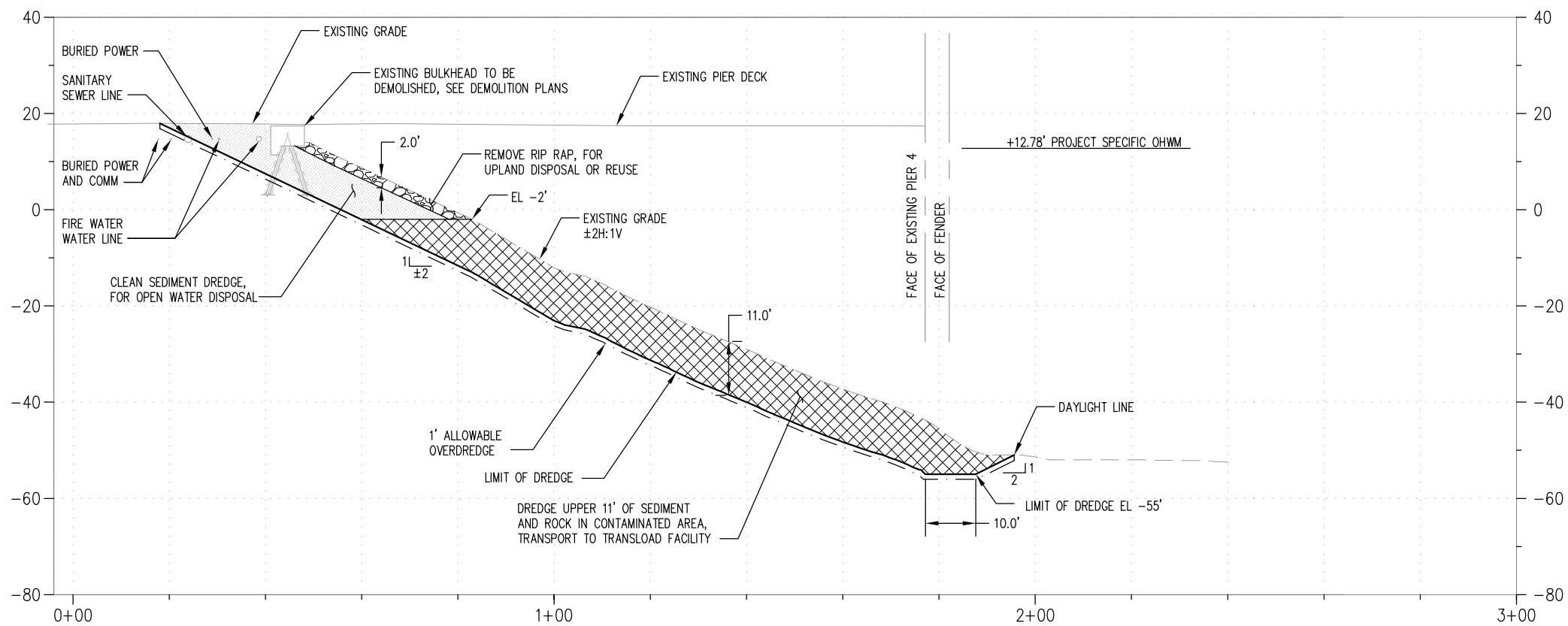

DATE: JANUARY 2015

SCALE: 1" = 30'-0"



B **FIGURE 5.4 DREDGE SECTION**
 FIG 5.2 SCALE: 1"=30'

LEGEND

-  DREDGE CONTAMINATED SEDIMENT AND ROCK ALONG DEMOLISHED PIER FACE AND UPPER 11FT OF SLOPE
-  DREDGE CLEAN SEDIMENT AND ROCK TO SAME DEPTH AS ADJACENT CONTAMINATED SEDIMENT AND ROCK, AND AT 2H:1V SLOPE UP TO EXISTING GRADE. DEPTH VARIES 8 FT TO 11 FT

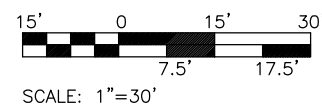

kpff Consulting Engineers

101 Stewart Street, Suite 400
 Seattle, Washington 98101
 (206) 382-0600 Fax (206) 382-0500

REMOVAL ACTION WORK PLAN
 PIER 4 PHASE 1 REMOVAL ACTION PROJECT
 TACOMA, WASHINGTON

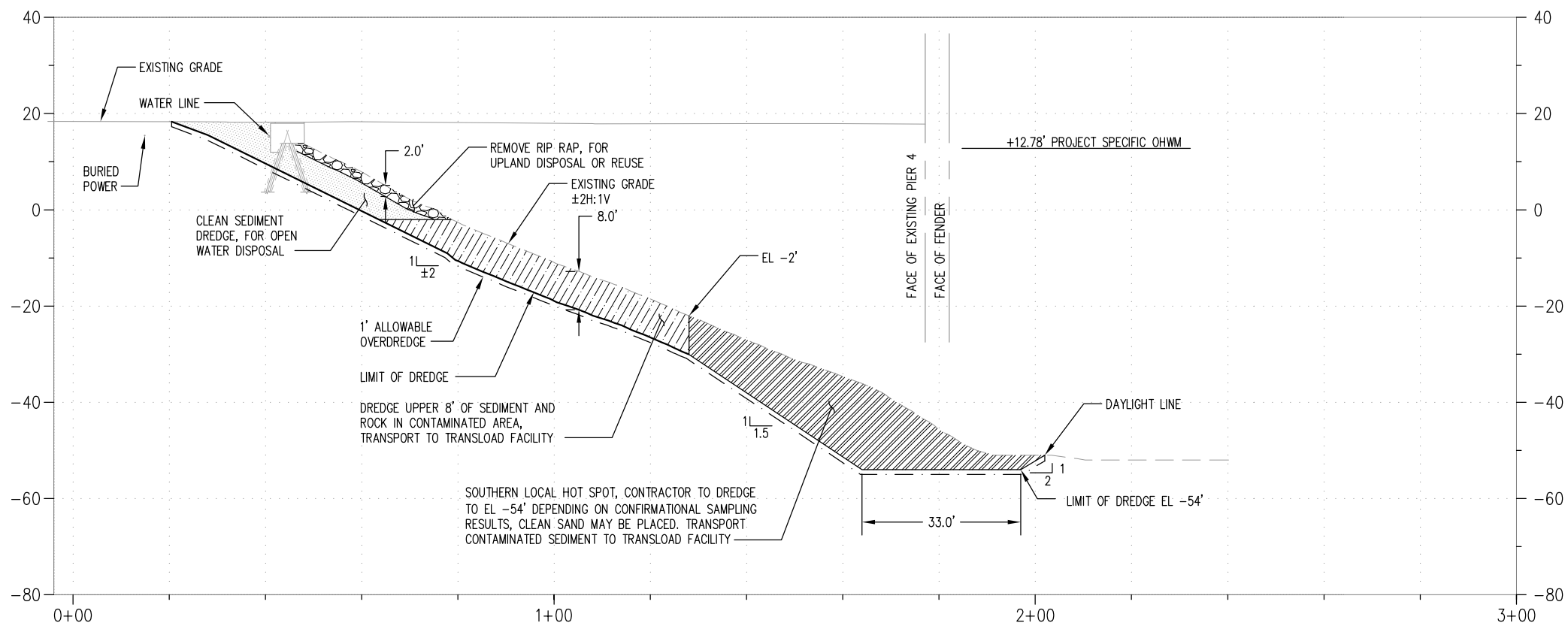

DATE: JANUARY 2015

SCALE: 1" = 30'-0"



C **FIGURE 5.5 DREDGE SECTION**
 FIG 5.2 SCALE: 1"=30'

LEGEND

-  DREDGE CONTAMINATED SEDIMENT AND ROCK ALONG DEMOLISHED PIER FACE AND UPPER 8FT OF SLOPE
-  DREDGE CLEAN SEDIMENT AND ROCK TO SAME DEPTH AS ADJACENT CONTAMINATED SEDIMENT AND ROCK, AND AT 2H:1V SLOPE UP TO EXISTING GRADE. DEPTH VARIES 8 FT TO 11 FT
-  SOUTHERN LOCAL HOT SPOT

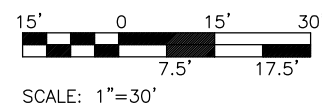

kpff Consulting Engineers

101 Stewart Street, Suite 400
 Seattle, Washington 98101
 (206) 382-0600 Fax (206) 382-0500

REMOVAL ACTION WORK PLAN
 PIER 4 PHASE 1 REMOVAL ACTION PROJECT
 TACOMA, WASHINGTON

DATE: JANUARY 2015

SCALE: 1" = 30'-0"



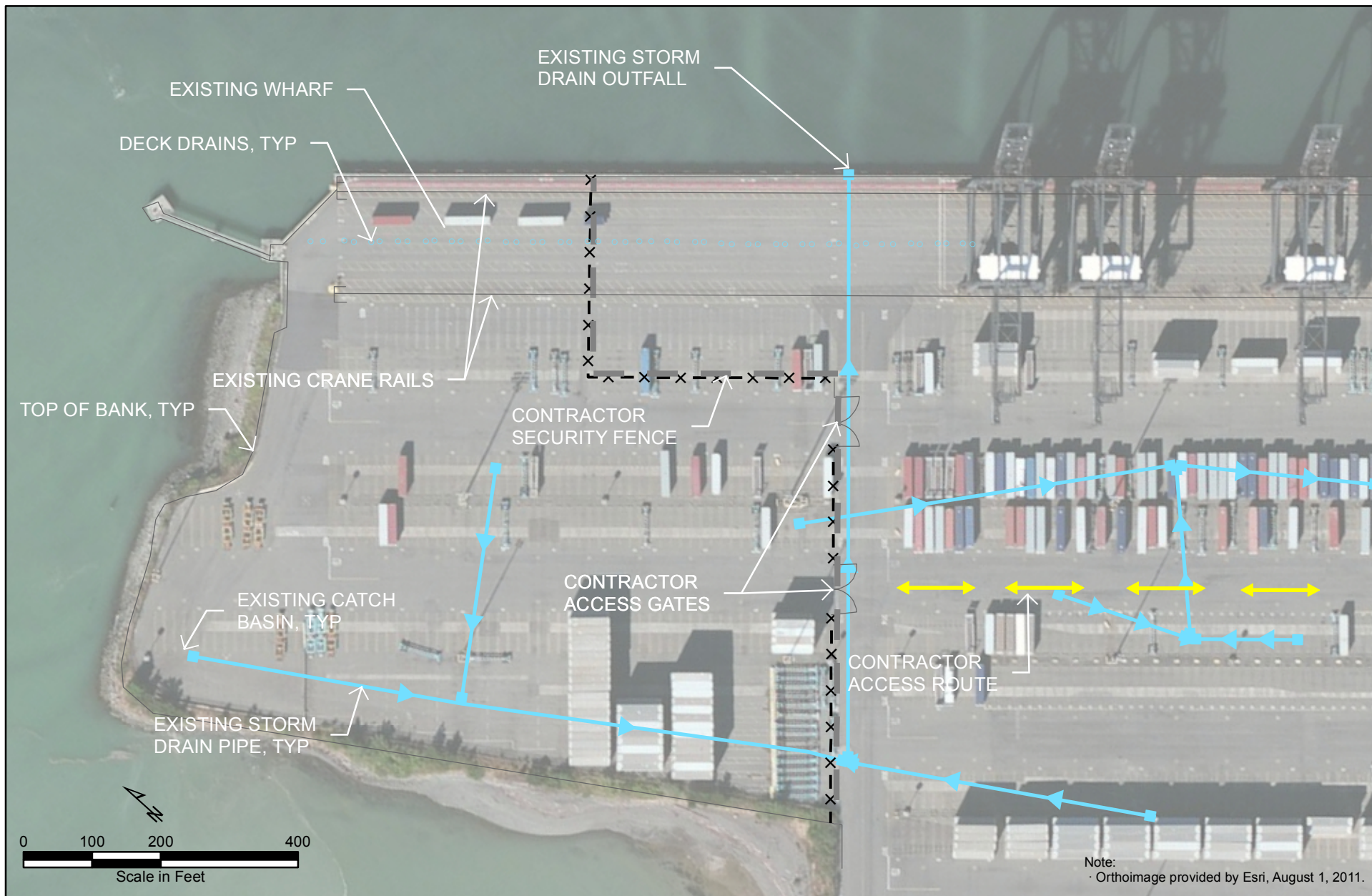

**Pier 4 Phase 1 Removal
Action Project**

Removal Action Work Plan

**Appendix A
Post-Dredge Confirmational Sampling Plan
and Associated Health and Safety Plan**

Table of Contents

1.0 Introduction A-1

1.1 PROJECT DESCRIPTION AND BACKGROUND A-1

1.1.1 Overview of Recent Investigations and Phase 1 Removal Action
Project Extent..... A-2

1.2 SUMMARY OF DREDGE DESIGN AND IMPLEMENTATION OBJECTIVES A-4

2.0 Project Team Organization and Responsibilities A-7

2.1 MANAGEMENT RESPONSIBILITIES A-7

2.1.1 Kathy Parker—USEPA On-Scene Coordinator A-7

2.1.2 Trevor Thornsley—Port of Tacoma Engineering Project Manager A-7

2.1.3 Scott Hooton—Port of Tacoma Environmental Project Manager A-7

2.1.4 Jessi Massingale—Floyd|Snider Project Coordinator..... A-7

2.2 QUALITY ASSURANCE RESPONSIBILITIES A-8

2.2.1 Erin Murray—Floyd|Snider Quality Assurance Manager A-8

2.3 LABORATORY AND DATA VALIDATOR RESPONSIBILITIES A-8

2.3.1 Kelly Bottem—Analytical Resources, Inc. Laboratory Project
Manager A-8

2.3.2 Christine Ransom—EcoChem Data Validation Project Manager A-8

2.4 FIELD RESPONSIBILITIES A-8

2.4.1 Kristin Anderson—Floyd|Snider Field Quality Assurance Officer A-8

3.0 Post-Dredge Confirmational Sampling..... A-9

3.1 POST-DREDGE CONFIRMATIONAL SAMPLING OBJECTIVES..... A-9

3.1.1 Dredge Residuals Evaluation..... A-9

3.2 POST-DREDGE CONFIRMATIONAL SAMPLING APPROACH..... A-11

3.2.1 Non-Hot Spot Areas A-11

3.2.2 Hot Spot Areas A-14

4.0 Perimeter Sampling..... A-19

4.1 PERIMETER SAMPLING OBJECTIVES AND RATIONALE..... A-19

4.2 PERIMETER SAMPLING APPROACH A-19

4.2.1 Sampling Density and Frequency..... A-19

4.2.2 Sampling Timing and Comparison to Tributyltin Criteria A-19

5.0 Sample Collection and Handling Procedures A-21

5.1 POSITIONING METHODOLOGY A-21

5.2 SAMPLE LOCATION AND SAMPLE IDENTIFICATION..... A-21

5.3 SEDIMENT GRAB SAMPLING METHODOLOGY A-21

5.4 SAMPLE COLLECTION AND HANDLING A-22

5.4.1 Sediment Grab Sampling Procedures A-22

5.4.2 Sediment Grab Sample Processing Procedures A-23

5.5 SAMPLING EQUIPMENT DECONTAMINATION..... A-24

5.6 FIELD QUALITY ASSURANCE SAMPLES A-24

5.7 SAMPLE TRANSPORT AND CHAIN-OF-CUSTODY PROCEDURES..... A-25

5.8 DISPOSAL OF INVESTIGATION-DERIVED WASTE..... A-25

6.0 Chemical Laboratory Analyses and Data Quality Objectives A-27

6.1 ANALYSIS PROGRAM..... A-27

6.2 LIMITS OF DETECTION..... A-27

6.3 QUALITY ASSURANCE/QUALITY CONTROL A-27

6.4 LABORATORY WRITTEN REPORT..... A-28

7.0 Data Validation and Reporting A-29

7.1 DATA VALIDATION A-29

7.2 PRELIMINARY DATA REPORTING TO USEPA A-29

7.3 FINAL REPORTING A-30

8.0 References A-31

List of Tables

Table A.1 Post-Dredge Confirmational and Perimeter Sampling and Analysis Scheme

Table A.2 Analytical Requirements, Methods, Preservation, Bottle Type, and Holding Times

List of Figures

Figure A.1 Site Location Map of Pier 4

Figure A.2 Phase 1 Dredge Areas and Design Dredge Cut Thicknesses

Figure A.3 Post-Dredge Confirmational Sample and Perimeter Sample Locations

List of Attachments

Attachment A.1	Contractor Signature Sheet
Attachment A.2	Dredge Residuals Evaluation
Attachment A.3	Sediment Sampling Health and Safety Plan

List of Acronyms and Abbreviations

Acronym/ Abbreviation	Definition
AOC	Agreed Order on Consent
bml	Below mudline
BMP	Best management practice
BT	Bioaccumulation trigger
cm	Centimeter
CY	Cubic yards
DGPS	Digital Global Positioning System
DMMP	Dredged Material Management Program
DMU	Dredge Management Unit
DQO	Data Quality Objective
IDW	Investigation-derived waste
LCS	Laboratory control sample
µg/kg	Micrograms per kilogram
µg/L	Micrograms per liter
MLLW	Mean lower low water
MS	Matrix spike
MSD	Matrix spike duplicate
Phase 1 Removal Action	Pier 4 Phase 1 Removal Action Project
Port	Port of Tacoma
PPE	Personal protective equipment
PSEP	Puget Sound Estuary Program
QA	Quality assurance
QAPP	Quality Assurance Project Plan

Acronym/ Abbreviation	Definition
QC	Quality control
RAWP	Removal Action Work Plan
RSER	Removal Site Evaluation Report
SL	Project Screening Level
TBT	Tributyltin
USACE	U.S. Army Corps of Engineers
USEPA	U.S. Environmental Protection Agency

1.0 Introduction

This Post-Dredge Confirmational Sampling Plan presents the procedures for the environmental sediment sampling activities that will be performed as part of the Port of Tacoma's (the Port) Pier 4 Phase 1 Removal Action Project (Phase 1 Removal Action) to address tributyltin (TBT)-contaminated sediments present at Pier 4. The Pier 4 site is located on the west side of the northern portion of the Blair Waterway that lies within the Port's Industrial Development District, adjacent to Commencement Bay in Tacoma, Washington (Figure A.1). Pier 4 is an active terminal that is currently operated by Husky Terminal and Stevedoring, Inc. for offloading shipping containers to trucks for transport.

The focus of the Phase 1 Removal Action is the mechanical dredging of approximately 49,000 cubic yards (CY) of TBT-contaminated sediments. In order to remove the contaminated sediments located under the existing pier and at the pier face, the majority of the existing Pier 4 structure will be demolished, including the vibratory extraction of under pier concrete piles and creosote treated timber and steel piles located at the pier face that are associated with the existing fender system. Also, prior to the removal of the TBT-contaminated sediments, approximately 9,000 CY of clean, non-TBT contaminated sediments, and 2,300 CY of clean riprap, located on the top of the slope, will be removed. The project construction activities and best management practices (BMPs) to be implemented are described in detail in the Removal Action Work Plan (RAWP).

The objective of the Phase 1 Removal Action is to dredge sediments contaminated with TBT at concentrations greater than the Dredged Material Management Program (DMMP) bulk sediment Bioaccumulation Trigger (BT) of 73 micrograms per kilogram ($\mu\text{g}/\text{kg}$).¹ Following the completion of all required dredging, post-dredge hydrographic surveys will confirm that design elevations and tolerances specified in this RAWP and the contract design and specifications were met. At this time, post-dredge confirmational sampling will be conducted to confirm whether removal to the TBT screening level (SL) of 73 $\mu\text{g}/\text{kg}$ has been achieved. In addition to confirmational sampling, perimeter sampling will be conducted outside of and around the perimeter of the dredge prism to verify the TBT concentration in the surface sediment outside of the dredge prism after the completion of dredging activities, and to confirm that no additional remedial actions are necessary.

1.1 PROJECT DESCRIPTION AND BACKGROUND

The Port is in the process of the design and permitting of the reconfiguration of Pier 4, which consists of aligning Pier 4 with Pier 3 within the Husky Container Terminal. As part of this process, Floyd|Snider, on behalf of the Port, conducted multiple soil and sediment sampling events in 2013 under the DMMP for the characterization of the project cutback material for open water

¹ Previous versions of the DMMP User Manual, which were available during Sampling and Analysis Plan development and the sampling event in April 2013, listed 73 $\mu\text{g}/\text{kg}$ as both the DMMP bulk sediment TBT SL and BT. These versions of the User Manual also listed 0.15 $\mu\text{g}/\text{L}$ as both the DMMP porewater TBT SL and BT; therefore, throughout the project, the DMMP TBT bulk sediment and porewater values of 73 $\mu\text{g}/\text{kg}$ and 0.15 $\mu\text{g}/\text{L}$ have been and are referred to in this plan as SLs.

disposal or beneficial habitat reuse. The results of the characterization events identified TBT-contaminated sediments underneath and at the face of Pier 4. In consultation with the U.S. Environmental Protection Agency (USEPA) and the DMMP representatives, and based on the TBT concentrations detected at Pier 4, the Port entered into an agreed order on consent (AOC) with USEPA in June 2014. The AOC called for a Removal Site Evaluation, which was conducted in July 2014. The results of the Removal Site Evaluation, as well as a recommended removal action, are summarized in the *Pier 4 Phase 1 Removal Action Project Removal Site Evaluation Report* (RSER; Floyd|Snider 2014a). The Port is entering into a second AOC with USEPA for the implementation of the Phase 1 Removal Action. This AOC also includes the preparation of the RAWP.

1.1.1 Overview of Recent Investigations and Phase 1 Removal Action Project Extent

The Phase 1 dredge plan is presented in Figure 5.2 of the RAWP. A cross section showing the boundary between the clean approximately 9,000 CY located at the top of slope and the TBT-contaminated sediments, as well as other Phase 1 Removal Action components, is presented in Figure 5.3 of the RAWP. Figure A.2 shows the TBT chemical results of the DMMP and USEPA Removal Site Evaluation sampling events, as well as the slope and pier face dredge extents and elevations.

The design dredge depths were increased relative to the Pier 4 Phase 2 Reconfiguration Project (Phase 2 Project) initial design prism elevations because sampling events confirmed the extents of the TBT contamination are deeper than the design elevations. The design dredge depths were conservatively increased further into clean material (confirmed to be clean per the 2013 and July 2014 sampling event results) to ensure the complete removal of TBT-contaminated sediments and to minimize dredge residuals as described below:

- **Under-Pier Slope Dredge Areas.** At each sample location, the bottom of the shallowest “clean” (i.e., the TBT concentration did not exceed the TBT SL of 73 µg/kg) 2-foot sampling interval was established as the top of the subsurface material proposed to be considered clean. For example, at a location where TBT did not exceed the bulk sediment TBT SL in a 4-to 6-foot below mudline (bml) sample interval, 6 feet bml was used as the bottom of the Phase 1 Removal Action dredge prism and the top of the subsurface material proposed to be considered clean. Several under-pier sample locations indicate that the current conceptual Phase 1 Removal Action dredge cut, using this approach, either reaches into native, or comes within approximately 1 foot of native.
- **Pier Face “Central Hot Spot.”** The TBT contamination maximum depth at Sample Location A8 extends to -54.8 feet mean lower low water (MLLW; the native interface at this location), deeper than the design dredge prism depth of -53 feet MLLW, including the overdredge allowance. However, in the RSER it was proposed that the dredge prism depth of the central hot spot area would extend to -56 feet MLLW for removal of TBT-impacted sediments. Following finalization of the RSER and USEPA approval, a dredge residuals evaluation was conducted that included the

- proposed multi-pass dredge approach to manage and minimize dredge residuals. As a result of this evaluation, the dredge prism depth of the central hot spot area extends an additional 1 foot deeper to -57 feet MLLW (and 4 feet deeper than the Phase 2 design dredge prism depth of -53 feet MLLW). This depth is over 2 feet into native material at Sample Location A8, and multiple feet into native material at the adjacent A17 location. The dredge residuals evaluation, associated results, and their application to the dredge approach is described below in Section 3.1.1.
- **Pier Face “Southern Hot Spot.”** The TBT contamination maximum depth at Sample Location B7 extends to -48 feet MLLW (1 foot above the native interface at this location). The concentration of TBT detected in samples collected from Sample Location B7, up to 9,300 µg/kg, is the basis of this southern area being considered a hot spot with additional dredge BMPs. In the RSER it was proposed that the dredge prism depth of the southern hot spot area would extend to -53 feet MLLW for removal of TBT-impacted sediments, based on the depth of the TBT-contaminated sediments encountered in the up slope dredge area and adjacent pier face (i.e., End of Pier and Surface Slope B). Following finalization of the RSER, a dredge residuals evaluation was conducted that included the proposed multi-pass dredge approach to manage and minimize dredge residuals. As a result of this evaluation the dredge prism depth of the southern hot spot area extends an additional 1 foot to -54 feet MLLW (and 1 foot deeper than the Phase 2 design dredge depth of -53 feet MLLW). This depth is over 5 feet into native material at Location B7. The dredge residuals evaluation, associated results, and their application to the dredge approach is described below in Section 3.1.1.

This conservative design dredge depth approach results in the dredge depth along the pier face ranging from -54 feet MLLW at the south end of the pier, to -57 feet MLLW at the central hot spot, and to -55 feet MLLW at the remaining portions of the pier face. Under the slope, the design dredge depth to remove all TBT-contaminated sediments, per the approach outlined above, includes an 8-foot dredge cut, an 11-foot dredge cut, and 9-foot dredge cut. The design dredge depths are shown on Figure A.2.

The necessary horizontal extents of the Phase 1 Removal Action dredge prism, and delineation between clean and TBT-contaminated sediments, were determined by the results of sediment sampling. These results are presented in the RSER and the memorandum submitted to the DMMP describing the proposed suitability of the clean material (Floyd|Snider 2014b).

The zone of clean sediment at the top of the under-pier slope in the central and southern portions of the pier was conservatively estimated to extend waterward to the sample locations at approximately -2 feet MLLW, where TBT was not detected at concentrations exceeding the DMMP SL; the material waterward of these sample locations is assumed to be contaminated.

1.2 SUMMARY OF DREDGE DESIGN AND IMPLEMENTATION OBJECTIVES

Multiple components of the Phase 1 Removal Action have been developed with the purpose of ensuring that TBT-contaminated sediments are efficiently and effectively removed, while minimizing the risk of elevated dredge residuals and impacts to the project schedule. These components and their objectives include the following:

- **Conservative increases in the dredge prism depth into material confirmed to be clean based on existing sampling results:** The bottom of the Phase 1 Removal Action dredge prism used for design was based on existing sample location data and was set at the bottom of the clean 2-foot samples underlying TBT-contaminated sediments, thereby, from the beginning, extending the dredged material into confirmed clean material rather than dredging just to the contaminated-clean sediment interface. The sample depth with the deepest extent of TBT contamination and the associated underlying clean sample was also conservatively applied throughout the dredge area.

Increasing the dredge prism depth provides the following project benefits:

- Minimizes the potential for missed inventory so that all TBT-contaminated sediments will be removed during the Phase 1 Removal Action.
 - Minimizes the TBT concentration of dredge residuals by dredging into confirmed clean material, thereby mixing potentially contaminated residuals with clean residuals.
 - Minimizes the potential time and schedule risk associated with re-dredging areas after post-dredge confirmational sampling due to missed inventory and/or contamination remaining from TBT-containing dredge residuals.
 - Accounts for potential TBT concentration variability between sample locations documented in the RSER.
- **Implementation of a multi-pass dredge approach:** The majority of the TBT-contaminated dredge depth will be removed in the first pass (vertical cut), followed by a second pass that removes a thinner layer (1 to 2 feet) of contaminated sediments, plus at least 2 feet of clean underlying sediment to the dredge design depth. The first pass conducted by the Contractor will likely consist of more than one lift or “bite” with the dredge bucket and will depend on the bucket size, slope conditions, and Contractor methodology. If the Contractor elects to use a smaller bucket, thinner residuals layers and lower post-construction surface sediment concentrations may result. Additionally, a third pass will be conducted in the hot spot areas, as part of the required dredging, for dredge residuals management. This provides the following project benefits:
 - Minimizes the potential time and schedule risk associated with re-dredging areas after post-dredge confirmational sampling by increasing sediment capture and reducing TBT concentrations in the final residuals.

- Minimizes the amount of time dredge cuts of TBT-contaminated sediment are exposed, thereby reducing scouring and transport of any low-strength residual layer, particularly in the hot spot (Palermo et al. 2008, Bridges et al. 2010).
- This approach also includes the restriction of the bucket swings so they occur only over the remaining contaminated material, following the first dredge pass, and not following the second pass (or third pass, where applicable), which prevents the potential loss of material from the bucket over clean areas.
- **Dredge Sequence:** The dredging will be conducted from the top of slope down to the toe of the slope. This provides the following project benefits:
 - Supports the natural angle of repose and avoids/minimizes sloughing of contaminated sediment downslope.
 - Results in a stable post-dredge slope configuration for Phase 2, following completion of the Phase 1 Removal Action.
 - Allows for a DMMP suitability approval of the Phase 2 sediment upon completion of Phase 1 Removal Action dredging.

This page intentionally left blank.

2.0 Project Team Organization and Responsibilities

Post-dredge confirmational sampling will be completed under the authorization of the Port and with USEPA approval. The various quality assurance (QA) field, laboratory, and management responsibilities of key project personnel are defined below. The Contractor Signature Sheet for all of the key project personnel can be found in Attachment A.1.

2.1 MANAGEMENT RESPONSIBILITIES

2.1.1 Kathy Parker—USEPA On-Scene Coordinator

Ms. Kathy Parker will have responsibility for project oversight on behalf of the USEPA. She will be involved in decisions regarding deviations from the Post-Dredge Confirmational Sampling Plan and additional sample analysis. Ms. Parker will review and approve the Time Critical Removal Action Report that will be done after completion of the Phase 1 Removal Action.

2.1.2 Trevor Thornsley—Port of Tacoma Engineering Project Manager

Mr. Trevor Thornsley is the Port's Engineering Project Manager and is responsible for day-to-day project management and the public works contracts associated with the Time Critical Removal Action.

2.1.3 Scott Hooton—Port of Tacoma Environmental Project Manager

Mr. Scott Hooton is the Port's Point of Contact and Project Manager for technical matters associated with the Administrative Settlement Agreement and Order on Consent for the Time Critical Removal Action.

2.1.4 Jessi Massingale—Floyd | Snider Project Coordinator

Ms. Jessi Massingale is the Floyd | Snider Project Coordinator for this project and will have overall responsibility for project implementation. She will be responsible for the overall QA during the Phase 1 Removal Action to ensure that it meets technical and contractual requirements, and will report directly to the Port's Project Manager and is responsible for technical quality control (QC) and project oversight. She will also support the Port in coordinating with the USEPA. Following plan approval by the USEPA, Ms. Massingale will be responsible for coordination to assure timely and successful completion of the post-dredge confirmational sampling. She will provide a copy of the approved Post-Dredge Confirmational Sampling Plan along with the USEPA's approval letter to all sampling and testing subcontractors. Any significant deviation from the approved Post-Dredge Confirmational Sampling Plan will be coordinated with the Port Project Manager and the USEPA On-Scene Coordinator.

2.2 QUALITY ASSURANCE RESPONSIBILITIES

2.2.1 Erin Murray—Floyd|Snider Quality Assurance Manager

The Floyd|Snider QA Manager reports directly to the Floyd|Snider Project Coordinator and will be responsible for ensuring that all QA/QC procedures for this project are being followed. The QA Manager will be responsible for laboratory coordination and managing data validation of all sample results from the analytical laboratories.

2.3 LABORATORY AND DATA VALIDATOR RESPONSIBILITIES

As described above, the analytical laboratory will perform all chemical analytical services in support of the Phase 1 Removal Action sampling activities. The data validation contractor will provide all data validation on all chemical data generated by field activities. The following project managers will be responsible for daily coordination with the Floyd|Snider QA Manager, as described below.

2.3.1 Kelly Bottem—Analytical Resources, Inc. Laboratory Project Manager

The Laboratory Project Manager will report directly to the Floyd|Snider QA Manager and will be responsible for ensuring all resources of the laboratory are available, advising the QA Manager on status, reviewing and approving final analytical reports, coordinating internal laboratory analyses and in-house chain-of-custody procedures, and overseeing data review.

2.3.2 Christine Ransom—EcoChem Data Validation Project Manager

The Data Validation Project Manager will report directly to the Floyd|Snider QA Manager and will be responsible for determining the validity of collected analytical data, in accordance with the analytical methods and data quality review guidance. The Data Validation Project Manager will advise the QA Manager on the status, review, and approval of the final data validation report.

2.4 FIELD RESPONSIBILITIES

2.4.1 Kristin Anderson—Floyd|Snider Field Quality Assurance Officer

The Floyd|Snider Field QA Officer will be responsible for leading and coordinating the day-to-day activities in the field. The Field QA Officer will report directly to the Floyd|Snider Project Coordinator and will provide overall direction for the field sampling in terms of logistics, personnel assignments, and field operations. She will supervise collection of the field samples and will be responsible for accurate sample positioning; recording sample locations, depths, and identification; ensuring conformance to sampling and handling requirements including field decontamination procedures; physical evaluation and logging of the samples; and ensuring chain-of-custody of the samples.

3.0 Post-Dredge Confirmational Sampling

3.1 POST-DREDGE CONFIRMATIONAL SAMPLING OBJECTIVES

The primary objective of the Phase 1 Removal Action confirmational sampling is to provide sufficient analytical data to determine whether the bulk TBT SL of 73 µg/kg or project Action Level (discussed below) have been achieved, or whether additional dredging passes and/or post-dredge sand placement are necessary, therefore, confirming that the removal action achieves the project objectives and removal action completion requirements. Bulk sediment TBT, rather than aqueous TBT in sediment porewater, was selected as the analysis method for confirmational sampling in order to be consistent with the sediment characterization data that was used to determine the extents of the Phase 1 Removal Action. Another project-specific objective is to provide adequate analytical data to determine that the removal of the contaminated material has been completed sufficiently so that underlying sediment that is within the Phase 2 Project dredge prism may be managed using either open-water disposal or beneficial use in support of a separate DMMP suitability determination.

Project-specific data quality objectives (DQOs) are presented in Section 6.0.

3.1.1 Dredge Residuals Evaluation

The dredge residuals evaluation and calculations included in Attachment A.2 and summarized below provide an estimation of the potential thicknesses and concentrations of dredge residuals that may be present within subareas of the Phase 1 Removal Action dredge prism; including those located along the slope and the two hot spot areas (Figure A.2). The calculation of dredge-generated residuals was carried out in accordance with Chapter 7 of the *Technical Guidelines for Environmental Dredging of Contaminated Sediments* (Palermo et al. 2008) using a multi-pass dredge approach.

The results of the evaluation are presented in Table A.2.3 of Attachment A.2. The results presented in each area include the residuals layer thickness and TBT concentrations within the top 1 foot and the top 10 centimeters (cm) of the post-dredge surface using the 95 percent upper confidence limit of site sediment concentrations. The dredge residuals evaluation includes the following results:

- Dredging residuals concentrations will be reduced in the short term (i.e., within a few weeks or months) following dredging, as the residuals re-consolidate to their original density. Following initial consolidation, the dredging residuals will occupy a proportionally smaller fraction of the top 10-cm biologically active zone, with the substrate becoming more stable and physically suitable for benthic colonization. Stable, long-term surface concentrations are expected to be 1.7 times to 2.6 times lower than the initial low-density condition as a result of short-term consolidation (refer to Attachment A.2).

- Final (i.e., following the last dredge pass and initial short-term sediment consolidation) residuals layer thicknesses range from 3.21 to 10.5 cm, with concentrations ranging from 15.3 to 278 $\mu\text{g}/\text{kg}$ (including the third pass as part of the required dredging within the hot spot areas).
- The greatest post-dredge residuals layer concentrations were predicted in the central hot spot area.
 - The predicted post-dredge residuals layer TBT concentration within the top 10 cm of the post-dredge surface following three passes in the central hot spot area was 278 $\mu\text{g}/\text{kg}$.
- The predicted post-dredge residuals layer TBT concentration within the top 10 cm of the post-dredge surface following three passes in the southern hot spot area was 38 $\mu\text{g}/\text{kg}$.
- The predicted post-dredge residuals layers of the non-hot spot areas are less than the bulk sediment TBT SL of 73 $\mu\text{g}/\text{kg}$.
 - The predicted post-dredge residuals layer TBT concentrations within the top 10 cm of the post-dredge surface within non-hot spot areas range from 15.3 to 35 $\mu\text{g}/\text{kg}$.
 - The predicted post-dredge residuals layer TBT concentrations within the top 1 foot of the post-dredge surface within non-hot spot areas range from 8.4 to 14.9 $\mu\text{g}/\text{kg}$.

The results of the dredge residuals evaluation are also conservative because a 1-foot overdredge allowance was assumed, rather than a 2 foot overdredge allowance. An additional increment of up to 1 foot below the required dredge elevations will be payable to the Contractor to account for equipment tolerance during the Phase 1 Removal Action; however, the maximum allowable overdredge is 2 feet below the required dredge elevation. If the maximum allowable overdredge of 2 feet is executed, this would result in deeper dredging into clean and/or native material, and the predicted dredge residuals TBT concentrations would be less than those presented in this evaluation.

The results of the dredge residuals evaluation within the dredge prism, excluding the central hot spot area, indicate that the predicted post-dredge surface sediments within the top 10 cm are less than the SL and that the proposed Phase 1 Removal Action dredge approach is anticipated to achieve the project objectives and removal action completion requirements. The results of the dredge residuals evaluation within the two hot spot areas indicate that, due to the predicted TBT concentrations of expected dredge residuals, the performance of an additional approximately 1-foot third pass and the potential placement of a minimum of 1 foot of clean sand as backfill throughout the TBT central hot spot area, are appropriate residuals management activities. By conducting a third pass of required dredging within the southern hot spot area an exceedance of the bulk sediment TBT SL of 73 $\mu\text{g}/\text{kg}$ is not expected.

3.2 POST-DREDGE CONFIRMATIONAL SAMPLING APPROACH

The effectiveness of the dredging and removal of TBT-contaminated sediment will be determined by the collection and analysis of post-dredge confirmational sediment grab samples.

The post-dredge top 10 cm is expected to consist of the low-strength, fluidized residual “fluff” layer that will consolidate to near surficial in situ densities within a period of a few weeks to months; therefore, the top 10 cm immediately after dredging is not representative of the post-dredging biologically active zone, which will include sediment deeper than the residuals layer following consolidation and compaction of the residuals layer. However, per USEPA and DMMP direction, a conservative approach of measuring only the top 10 cm for comparison to the TBT SL to provide confirmation of the completion of the Phase 1 Removal Action will be implemented.

Following the completion of the dredging of the TBT-contaminated sediments, the majority of sediments underlying the Phase 1 dredge prism will be subsequently dredged to reconfigure Pier 4 in alignment with Pier 3. This results in the Phase 1 post-dredge surface being the “new” sediment surface for a finite amount of time, and not a long-term biologically available sediment surface.

3.2.1 Non-Hot Spot Areas

Following completion of all required dredging² in non-hot spot dredge areas grab samples will include the collection of the top 0 to 10 cm of the post-dredge sediment surface for immediate bulk sediment TBT analysis, as well as the collection and immediate analysis of the underlying 10 to 20 cm deep sample to provide information on the vertical extent of the dredge residuals layer and potential TBT exceedances of the bulk sediment TBT SL, if they are detected in the surface 0 to 10 cm. These areas are within the dredge prism of the additional dredging that will occur during the Phase 2 Project.

3.2.1.1 Sampling Density and Frequency

The Phase 1 dredge prism is approximately 2.5 acres (105,300 square feet). The post-dredge confirmational sampling density is based on a determination using the procedure provided by the USEPA in “Methods for Evaluating the Attainment of Cleanup Standards, Volume 1: Soils and Solids Media” (USEPA 1989). The procedure is based on a statistical hypothesis test for determining whether a proportion of material remaining at a site is less than a cleanup standard and requires that the criteria listed in the table below be specified.

² In coordination with USEPA, if dredging is delayed in an area due to dredging equipment issues or capacity constraints at the Transload Site, post-dredge confirmational samples may be collected in Dredge Management Units (DMUs) where dredging is complete. However, to ensure additional dredging does not affect the post-dredge surface quality of remaining DMUs, the sampling will not be conducted in DMUs that are adjacent to DMUs that have not yet been dredged.

The associated equation (Equation 1) used to determine the sample frequency, n , is:

$$n = \left(\frac{z_{\beta} \sqrt{P_1(1 - P_1)} + z_{\alpha} \sqrt{P_0(1 - P_0)}}{P_0 - P_1} \right)^2$$

Where:

z_{α} is the standard normal value with upper tail probability α .

z_{β} is the standard normal value with upper tail probability β .

The criteria P_0 , P_1 , α , and β are described in the following table. In general, n determined from Equation 1 is rounded up to the nearest integer.

Criteria for Determining if a Site Meets the Cleanup Standard

Criteria	Definition and Comment
α	<p>The Type 1 error rate (false positive rate) for a one-sided statistical hypothesis test. Usually, α is set at 0.05 or 0.1. The null hypothesis for this test is $H_0: P \geq P_0$ and the alternative hypothesis is $H_a: P < P_0$, where P is the true proportion of sediment that does not meet the cleanup criteria. The desired outcome is to reject the null hypothesis in favor of the alternative.</p> <p>Value for Pier 4 Phase 1: α is set to 0.1 to obtain a statistical power of 0.9.</p>
β	<p>The probability that the sediment will fail the sediment verification criteria if the true proportion of sediment that fails the criteria is P_1. β is the false negative rate. $1 - \beta$ is the statistical power of the test. The power of the test is generally 0.8 or greater.</p> <p>Value for Pier 4 Phase 1: To obtain a statistical power of 0.8, β is set to 0.2.</p>
P_0	<p>The maximum proportion of sediment that may be allowed to be out of compliance is P_0. This is generally set between 0.1 or 0.2, but may be any value acceptable to the regulatory agency (or agencies) providing oversight to the project. P_0 should be set to a value greater than zero.</p> <p>Value for Pier 4 Phase 1: P_0 is set to 0.15.</p>
P_1	<p>The proportion of sediment that fails the compliance criteria under the alternative hypothesis for which the false negative rate is to be controlled. This must be less than P_0. P_1 can be thought of as the value less than P_0 that must be designated clean by the statistical test with great certainty. That is, the number of samples that are allowed to be incorrectly designated clean is lower if P_1 is smaller.</p> <p>P_1 could be set equal to zero, but this would imply that all samples (for sample size n estimated by Equation 1) must meet the compliance criteria in order to conclude that the true proportion of sediment that meets the compliance criteria is less than or equal to P_0, resulting in a lower number of samples required.</p> <p>Value for Pier 4 Phase 1: P_1 is set to 0.01.</p>

This calculation results in a post-dredge confirmational sample location density of 15. A total of 17 post-dredge confirmational sediment sample locations are evenly distributed to conservatively provide the required coverage of 15 samples over the approximate 2.5-acre dredge prism footprint, including an additional sample location positioned directly upslope of the central hot spot area (refer to Figure A.3). Each post-dredge confirmational sample location is representative of a DMU for a total of 17 DMUs (i.e., DMU 1 through DMU 17). The size range of the DMUs occurs because of the irregular dredge prism boundaries and the extent of TBT contamination.

3.2.1.2 *Sampling Timing and Comparison to Tributyltin Criteria*

Non-hot spot post-dredge confirmational sampling will be conducted at the completion of dredging as determined by confirmational surveys and achievement of the design elevations and tolerances specified in the RAWP and the contract design and specifications. In the non-hot spot areas, the 0- to 10-cm bml surface sample and 10- to 20-cm sample bulk sediment TBT results will both be compared to the DMMP SL of 73 $\mu\text{g}/\text{kg}$.

- If the TBT concentration detected in the 0- to 10-cm surface sample exceeds 73 $\mu\text{g}/\text{kg}$ and the TBT concentration detected in the 10- to 20-cm sample is less than 73 $\mu\text{g}/\text{kg}$, the Contractor will conduct one additional dredge pass of the DMU represented by the confirmational sample(s), as shown on Figure A.3. The 10- to 20-cm bml sample with a TBT concentration less than 73 $\mu\text{g}/\text{kg}$, will serve as the confirmational sample for the additional dredge pass and DMU, and additional sampling will not be required.
- If the TBT concentration exceeds 73 $\mu\text{g}/\text{kg}$ in both the 0- to 10-cm and 10- to 20-cm samples, an additional dredge pass will be conducted of the DMU represented by the confirmational samples. Following the additional dredge pass, which will consist of a 1- to 2-foot lift, a 0- to 10-cm surface sample will be collected as the DMU confirmational sample.

During the collection of the 0- to 10-cm and 10- to 20 cm samples, the sediment composition and physical characteristics will be logged and well documented to aid in the ability to assess the boundary of the dredge residuals and underlying clean material, and in the majority of areas, native material. The dredge residuals evaluation, as described above, resulted in predicted dredge residuals thicknesses in the non-hot spot areas of approximately 10 cm. The collection of the 0- to 10-cm and 10- to 20-cm intervals allows for the complete characterization of dredge residuals and the un-dredged underlying sediment.

The post-dredge confirmational and perimeter sampling and analysis scheme is presented in Table A.1 and includes the number of surface sediment grab locations and the total number of samples to be collected within the non-hot spot areas, as well as the hot spot areas and perimeter samples, as described in the following sections.

3.2.2 Hot Spot Areas

As described in Section 1.1.1, based on the distribution of bulk sediment TBT concentrations, there are two hot spot areas where TBT concentrations are greater than 1,000 µg/kg: the central hot spot and the southern hot spot. The quality of the post-dredge surface will be evaluated by the collection and analysis of post-dredge confirmational sediment grab samples. Grab samples will include the collection of the top 0 to 10 cm of the post-dredge surface for immediate analysis of bulk sediment TBT. Samples may also be collected from the 10- to 20-cm bml depth for informational purposes.

3.2.2.1 *Sampling Density and Frequency*

As described above in Section 3.2.1.1, a statistical determination of the appropriate post-dredge confirmational sampling density was conducted and resulted in a post-dredge confirmational sample location density of 15. A total of 17 post-dredge confirmational sediment sample locations are evenly distributed to conservatively provide the required coverage of 15 samples over the approximate 2.5-acre dredge prism footprint, including an additional sample location positioned directly upslope of the central hot spot area (refer to Figure A.3). A total of three of these surface grab sample locations are positioned within the hot spot areas; two within the central hot spot area and one within the southern hot spot area. Each post-dredge confirmational sample location is representative of a DMU, as shown on Figure A.3.

3.2.2.2 *Sampling Timing and Comparison to Tributyltin Criteria*

Hot spot post-dredge confirmational sampling will be conducted when the dredging of the Phase 1 dredge prism is complete as determined in coordination with the USEPA by confirmational surveys and achievement of the design elevations and tolerances specified in the RAWP and the contract design and specifications.

As described in Section 1.2, the dredging sequence will include conducting the dredging from top of slope down to the toe of the slope. This sequence will be implemented for slope stability considerations, to support the natural angle of repose and avoid/minimize sloughing of contaminated sediment downslope.

The post-dredge PD confirmational and perimeter sampling and analysis scheme is presented in Table A.1 and includes the number of surface sediment grab locations and the total number of samples to be collected within the hot spot areas.

The bulk sediment TBT concentration measured in the 0- to 10-cm surface grab samples collected from the hot spot areas will be compared to the DMMP SL of 73 µg/kg.

In the central hot spot area, the following dredge actions will be conducted based on the comparison of TBT concentrations detected in post-dredge confirmational samples to the TBT criteria, in coordination with USEPA:

- If the post-dredge confirmational sample bulk sediment TBT concentrations are less than 73 $\mu\text{g}/\text{kg}$, no additional action is needed and the Phase 1 Removal Action within the central hot spot area will be complete.
- If the post-dredge confirmational sample bulk sediment TBT concentrations following the completion of the required dredging are greater than 73 $\mu\text{g}/\text{kg}$, but less than 219 $\mu\text{g}/\text{kg}$ (i.e., three times the DMMP SL, referred to as the “Project Action Level”), the Port, in coordination with USEPA, will determine the appropriate next steps. These may include:
 - No action.
 - Re-sampling of the area to address the variability in analytical results due to the heterogeneous distribution of TBT in sediments or to focus on particular areas of concern.
 - Enhanced Natural Recovery through thin lift placement of clean sand, with a minimum placement of 1 foot of clean sand to provide a physical barrier to the underlying sediment. The clean backfill sand will be outside of the Phase 2 dredge prism footprint and will not be disturbed by that dredging.
 - Additional dredging, as described below.
- If the post-dredge confirmational sample bulk sediment TBT concentrations following completion of the required dredging are greater than 219 $\mu\text{g}/\text{kg}$, the Contractor will conduct an additional dredge pass.
- If additional dredging is conducted to an elevation of -59 feet MLLW,³ additional 0- to 10-cm confirmational samples will be collected. Additional dredging below -59 feet MLLW is geotechnically constrained, and will not be conducted.
 - If detected TBT concentrations in confirmational samples following the completion of the additional dredging are greater than the DMMP SL, a 1-foot-thick layer of clean sand will be placed.
 - The Port may also choose to place the 1-foot-thick layer of sand prior to receipt of confirmational sample analytical results, if desired, to support the Contractor and project schedule.

As summarized above and presented in Attachment A.2, the results of the dredge residuals evaluation indicate that within the central hot spot area the predicted dredge residuals TBT concentration within the surface layer (0 to 10 cm) is 278 $\mu\text{g}/\text{kg}$. Placement of a minimum of 1 foot of clean backfill material (sand) would result in a minimum reduction in these

³ The central hot spot required dredge elevation is to -57 feet MLLW, with up to a maximum 2-foot allowable overdredge to -59 feet MLLW.

concentrations by a factor of 4, assuming complete mixing of the top 10-cm post-dredge layer and clean cover sand.

Due to dredging to the deeper elevation within the central hot spot area (and deeper than the Phase 2 design dredge prism depth of -53 feet MLLW), relative to the upper slope dredge cut, it is anticipated that localized sloughing will occur.

Although localized sloughing is expected during the hot spot dredging, it is anticipated that the hot spot side slopes will remain relatively stable globally (although steeper than the upslope area), and the dredge cut can be left open, as necessary, for the collection and analysis of the post-dredge confirmational samples without presenting a risk of undermining the entire upper slope. Localized removal of sloughed material in the vicinity of a sample location will most likely be required prior to confirmational surveys to ensure the design elevation has been achieved and prior to collecting confirmational samples.

As described above, the design dredge depth is conservatively increased in the dredge prism into material confirmed to be clean (and deeper than the Phase 2 design dredge prism depth of -53 feet MLLW) based on existing sampling results to maximize the potential that all TBT-contaminated sediments will be removed during dredging and minimize the generation of dredge residuals with elevated TBT concentrations by dredging into confirmed clean material. The increased dredge depth within the hot spot areas is beyond the depths necessary for the Phase 2 cutback design in order to ensure the removal of TBT contamination. This results in the hot spot areas no longer remaining within the Phase 2 cutback dredge prism. This also results in the final post-dredge, as well as potential backfill elevation within the central hot spot area being deeper than the potential future USACE channel elevation of -56 feet MLLW. Therefore, the potential backfilling of the central hot spot area with clean material to physically separate a thin layer (predicted to be 3 cm, refer to Table A.2.3 of Attachment A.2) of post-dredge sediment with residual TBT concentrations less than 3 times greater than the DMMP SL will not provide a risk to the environment.

In the southern hot spot area, the following dredge actions will be conducted, in coordination with USEPA, based on the comparison of TBT concentrations detected in post-dredge confirmational samples to the TBT criteria:

- If the post-dredge confirmational sample bulk sediment TBT concentrations following the required dredging are less than 73 $\mu\text{g}/\text{kg}$, no additional action is needed and the Phase 1 Removal Action within the southern hot spot area will be complete.
- If the post-dredge confirmational sample bulk sediment TBT concentrations following the required dredging are greater than 73 $\mu\text{g}/\text{kg}$, but less than 219 $\mu\text{g}/\text{kg}$ (i.e., three times the DMMP SL, the Project Action Level), the Port, in coordination with USEPA, will determine the appropriate next steps. These may include:
 - No action.
 - Re-sampling of the area, to address the variability in analytical results due to the heterogeneous distribution of TBT in sediments or to focus on particular areas of concern.

- Enhanced Natural Recovery through thin lift placement of clean sand, with a minimum placement of 1 foot of clean sand to provide a physical barrier to the underlying sediment. The clean backfill sand would be outside of the Phase 2 dredge prism footprint and will not be disturbed by that dredging.
- Additional dredging, as described below.
- If the TBT concentration exceeds 219 $\mu\text{g}/\text{kg}$ in the 0- to 10- cm post-dredge confirmational sample, an additional dredge pass will be conducted. After this dredge pass, additional samples will be collected and evaluated as described above.

As summarized above and presented in Attachment A.2, the results of the dredge residuals evaluation indicate that, by conducting a third pass of dredging as part of the required dredging within the southern hot spot area, an exceedance of the bulk sediment TBT SL of 73 $\mu\text{g}/\text{kg}$ is not expected.

This page intentionally left blank.

4.0 Perimeter Sampling

4.1 PERIMETER SAMPLING OBJECTIVES AND RATIONALE

The specific objective of the perimeter sampling is to provide sufficient analytical data to verify TBT concentrations in surface sediment outside of the Phase 1 Removal Action dredge prism after the completion of dredging activities and confirm that no additional remedial actions are necessary.

Project-specific DQOs are presented in Section 6.0.

4.2 PERIMETER SAMPLING APPROACH

Perimeter surface sediment grab sample locations are positioned around the perimeter of the Phase 1 dredge prism: north, south, and waterward of the prism to the east. The perimeter grab samples will include the collection of the top 0 to 10 cm of the sediment surface for immediate analysis of TBT in bulk sediment.

4.2.1 Sampling Density and Frequency

The perimeter surface sediment sample locations are shown on Figure A.3. Surface 0- to 10-cm sediment samples will be collected from a total of 22 sample locations. A total of 4 of the surface sediment samples will be collected from locations positioned to the north and south of the Phase 1 dredge prism (PR-1 through PR-3 and PR-22, respectively), and 18 of the surface sediment samples will be collected waterward of the dredge prism. Each perimeter sample location waterward of the dredge prism is representative of an approximately 40-foot by 195-foot area, except for sample locations directly waterward of the central and southern hot spot areas, which are smaller (40-foot by 96-foot area). Because the maximum TBT sediment concentrations have been detected within the central and southern hot spot areas, and these are the areas with the greatest predicted dredge residuals concentrations, a total of six of the surface sediment samples will be collected directly waterward, approximately 27 feet from the waterward boundaries of the hot spot areas (PR-15 through PR-18, and PR 20 and PR-21). Each of these perimeter samples is representative of an approximately 40-foot by 96-foot area.

Potentially, up to five additional discretionary perimeter samples may be added in coordination with USEPA based on the results of the post-dredge confirmational sampling results within the hot spot areas and/or water quality monitoring results during dredging. The results of water quality monitoring, will be used by the Port and USEPA, to inform the potential need or benefit of any additional discretionary perimeter sample locations.

4.2.2 Sampling Timing and Comparison to Tributyltin Criteria

Perimeter surface sediment sampling will be conducted when the Phase 1 Removal Action dredge prism is confirmed to be dredged to the design elevations and tolerances specified in the RAWP and the contract drawings and specifications.

Post-dredge confirmational sampling and perimeter sampling will both be conducted at the same time, once the Phase 1 Removal Action dredge prism is confirmed to be dredged to the design elevations (defined as the required dredging). Two sampling vessels will be used to minimize contractor stand-by time; one will conduct post-dredge confirmational sampling within the Phase 1 dredge prism and the other will conduct perimeter surface sediment sampling outside of the dredge prism.

The bulk sediment TBT of the perimeter 0- to 10-cm surface sediment samples will be compared to the bulk sediment TBT DMMP SL of 73 $\mu\text{g}/\text{kg}$.

The following actions will be conducted based on the comparison of TBT concentrations detected in perimeter samples to the TBT criteria, in coordination with USEPA:

- If the perimeter sample bulk sediment TBT concentrations are less than 73 $\mu\text{g}/\text{kg}$, no additional action is needed within the represented perimeter area.
- If the perimeter sample bulk sediment TBT concentrations are greater than 73 $\mu\text{g}/\text{kg}$, but less than 219 $\mu\text{g}/\text{kg}$ (i.e., three times the DMMP SL, the Project Action Level), the Port, in coordination with USEPA, will determine the appropriate next steps. These may include:
 - No action.
 - Re-sampling of the perimeter area to address the variability in analytical results due to the heterogeneous distribution of TBT in sediments or to focus on particular areas of concern.
 - Enhanced Natural Recovery through thin lift placement of clean sand, with a minimum placement of 1 foot of clean sand to provide a physical barrier to the underlying sediment. The clean backfill sand would be outside of the Phase 2 dredge prism footprint and will not be disturbed by that dredging.
 - Dredging in the perimeter area, as described below.
- If the perimeter sample bulk sediment TBT concentrations are greater than 219 $\mu\text{g}/\text{kg}$, then the Contractor will be required to dredge the minimum surface sediment layer feasible with the dredge equipment, which is approximately 1 to 2 feet of surface sediment within the area represented by the perimeter sample. After this dredge pass, additional samples will be collected and evaluated as described above.

5.0 Sample Collection and Handling Procedures

This section describes the sample collection and handling procedures for both the post-dredge confirmational sampling and perimeter sediment sampling that will be conducted when the Phase 1 Removal Action dredge prism is confirmed to be dredged to the design elevations and tolerances specified in the RAWP and the contract drawings and specifications. A health and safety plan for the post-dredge confirmational sampling is provided in Attachment A.3.

As stated in Section 4.2.2 above, two sampling vessels will be used to minimize Contractor stand-by time; one will conduct post-dredge confirmational sampling within the Phase 1 dredge prism following the completion of all required dredging, and the other will conduct perimeter surface sediment sampling outside of the dredge prism.

5.1 POSITIONING METHODOLOGY

Sample locations for post-dredge confirmational and perimeter sampling will be determined in latitude and longitude using a Digital Global Positioning System (DGPS) receiver referenced to North American Datum of 1983 (NAD 83) to the nearest 0.1 second. The accuracy of measured and recorded horizontal coordinates will be within ± 2 meters.

Sample location coordinates will be logged into the GPS onboard the sampling vessel. The onboard GPS with associated depth finder or a leadline will be used to determine water depth at all locations. All proposed field locations are approximate target locations, but may be modified slightly based on field conditions.

5.2 SAMPLE LOCATION AND SAMPLE IDENTIFICATION

Sediment samples collected from within the dredge prism will be numbered according to their DMU, and top and bottom sample depths, in centimeters. For instance, a sample collected from 0 to 10 cm bml at Sample Location 3 within DMU 3 would be named "DMU-03-0-10." Perimeter samples will be numbered similarly, according to their perimeter sampling area; for instance, the sample collected from 0 to 10 cm bml at Sample Location PR-11 would be named "PR-11-0-10." The sample containers will also be labeled with the date and time of sample collection.

The post-dredge confirmational and perimeter sample locations are shown on Figure A.3. The total number of samples to be collected and applicable SLs for comparison of sample results are presented in Table A.1.

5.3 SEDIMENT GRAB SAMPLING METHODOLOGY

Surface sediment grab samples will be collected from a vessel equipped with a pneumatic power grab sampler (equivalent to a Van Veen grab sampler) or a Van Veen sampler. The power grab sampling assembly is a 0.2-square-meter sampler used to collect large-volume surface samples from the top 20 cm of the sediment surface. A pneumatic ram closes the grab around surface

sediment and brings it to the surface for processing. Sediment grab samples will be collected from the locations as shown in Figure A.3.

5.4 SAMPLE COLLECTION AND HANDLING

All sampling will be done in accordance with DMMP and Puget Sound Estuary Program (PSEP) procedures (PSEP 1986), consistent with previous sampling events. Logs and field notes of all samples will be maintained during sampling activities. The following will be included in all sampling logs:

- The sample station number, as derived from this Post-Dredge Confirmational Sampling Plan.
- Weather conditions.
- Measured elevation of each station sampled as measured from MLLW.
- Station location determined in latitude and longitude using a GPS.
- Date and time of collection of each sample.
- Names of field person(s) collecting and logging in the sample.
- Any deviation from the approved sampling plan.

5.4.1 Sediment Grab Sampling Procedures

The general procedure for collecting surface sediment samples is as follows:

1. Maneuver the sampling vessel to the sample locations shown on Figure A.3, and verify location control using the positioning procedures described in Section 5.1.
2. Guide the sampler overboard until it is clear of the vessel.
3. Lower the sampler through the water column to the bottom, onto the sample location at a slow and controlled rate.
4. Record the coordinate location on the field form.
5. Record the time, depth to mudline below water surface, and estimated tide elevation on the field form.
6. Retrieve the sampler by raising at a slow and controlled rate.
7. Guide the sampler on board the vessel and place it on the work surface on the deck; use care to avoid jostling that might disturb the integrity of the sample.
8. Examine the sample for the following sediment acceptance criteria:
 - a. Sampler jaw is closed.
 - b. The sample does not contain foreign objects.
 - c. The sampler is not overfilled so that the sediment surface presses against the top of the sampler.

- d. No leakage has occurred, as indicated by overlying water on the sediment surface.
 - e. No sample disturbance has occurred, as indicated by limited turbidity in the overlying water.
 - f. No winnowing has occurred, as indicated by a relatively flat undisturbed surface.
 - g. A penetration depth of at least 21 cm has been achieved.
9. If sample acceptance criteria are not achieved, the sample will be rejected and the location resampled. If the sample location cannot be achieved (within ± 2 meters), notify the Floyd|Snider Project Coordinator to determine an appropriate alternate location. Changes to the sample locations will be coordinated with the USEPA for review and approval prior to implementing changes.
 10. Siphon off any standing water from the surface of the sediment using a hose primed with site water. Care should be taken not to disturb the integrity of the sediment surface.

5.4.2 Sediment Grab Sample Processing Procedures

Sediment grabs will be processed on board the sampling vessel. All working surfaces and instruments will be thoroughly cleaned and decontaminated between sample locations. Disposable latex/nitrile gloves will be changed between sample locations to prevent cross contamination. Sample container requirements are summarized in Table A.2. The steps for sample processing are described below:

1. Take a digital photograph of the sediment surface prior to removal from the sampler. Write the sample location name and grab replicate number with a large felt-tip marker on a sheet of paper and photograph next to, but not touching, the sediment sample.
2. Visually classify sediment in accordance with ASTM D 2488 methods and the Unified Soil Classification System (ASTM D 2487) using the Soil and Stratigraphic and Geotechnical Field Guides and record on the field form. In addition to the visual classification, qualitative descriptive parameters, including biota, debris, staining, sheen, and other observations should also be recorded.
3. Collect the upper 10 cm and the 10 to 20 cm of sediment from the sampler using a clean, stainless steel spoon. Using a stainless steel spoon, place sample material for each interval from the grab separately into a cleaned stainless steel bowl and homogenize until the sediment appears uniform in color and texture.
4. Distribute the homogenized sediment to appropriate sample containers and ensure that sample labels are completely filled out and affixed to the containers.
5. Clean the exterior of all sample containers and store them in a cooled ice chest away from the immediate work area aboard the vessel. The cooled ice chest will be maintained at 4 °C.

6. Thoroughly rinse the interior of the sampler until all loose sediment has been washed off. Excess sediment will be taken to the transload site for inclusion with dredged sediment or collected for disposal, as described in Section 5.8.
7. Thoroughly decontaminate the sampler by following the procedure in Section 5.5.
8. Ensure that sediment descriptions and supporting field form entries are complete.

5.5 SAMPLING EQUIPMENT DECONTAMINATION

Field sampling equipment for reuse, such as stainless steel spoons and bowls and the power grab sampler, will be cleaned before the start of work and will be cleaned between each sample location. Equipment will be decontaminated aboard the sampling vessel. Decontamination will be performed before each sample is collected, in accordance with PSEP protocols (PSEP 1986) and standard good practices, following the procedure below:

- Water rinse or spray to dislodge remaining sediments from previous sample location.
- Wash with Alconox soap.
- Rinse with site water.
- Triple rinse with distilled water.
- Do not use solvent or acid washes because of safety, rinsate disposal, and sample integrity considerations.

After cleaning, all sampling equipment not used immediately will be wrapped in aluminum foil and/or stored in plastic bags. The rule of “potential for contaminants” will be used such that any sampling equipment suspected of contamination will be rejected and decontaminated prior to use.

5.6 FIELD QUALITY ASSURANCE SAMPLES

Field QA samples will be used to evaluate the efficiency of field decontamination procedures. Field duplicate samples will be collected at a frequency of 1 per 10 field samples for sediment and submitted as blind duplicates with fictitious sample names.

Extra sample volume will also be collected for matrix spike (MS)/matrix spike duplicates (MSDs) at a frequency of 1 sample per 20 field samples.

Because exposure to TBT may result in possible detections due to sorption onto non-dedicated sampling equipment, a rinsate blank will be collected from non-dedicated equipment (e.g., stainless steel bowl used for sample homogenization) after the equipment has been cleaned following the decontamination procedure described in Section 5.5. A rinsate blank will be collected at a frequency of one sample per sampling event. Rinsate blanks will be collected by pouring laboratory-supplied deionized water over the surfaces of the equipment that have contacted sample material and collecting this rinsate water in sample bottles.

5.7 SAMPLE TRANSPORT AND CHAIN-OF-CUSTODY PROCEDURES

The samples for chemical analysis will be transported to the analytical laboratory when the sampling is completed. Chain-of-custody procedures will be used to track sample handling from field collection through delivery of the samples to the laboratory. Specific procedures will be as follows:

- Sample coolers will be kept at a temperature of 4 ± 2 °C.
- Chain-of-custody forms will be enclosed in a plastic bag and taped to the inside lid of the cooler.
- Sample coolers will be transported either by courier or vehicle to the analytical laboratory. Samples will be delivered and analyzed within the required method holding time and laboratory turnaround times.

For the bulk sediment TBT method, the required holding time is 14 days to extract, then 40 days to analyze. The expedited laboratory turnaround time for this method is approximately 3 days.

5.8 DISPOSAL OF INVESTIGATION-DERIVED WASTE

Investigation-derived waste (IDW) is likely to include excess sediment from grab sampling and disposable materials used during field work that may be impacted by contaminated media, or decontamination wash water (e.g., disposable personal protective equipment [PPE], plastic sheeting, paper towels, etc.). Excess sediment from grab sample collection will be collected in buckets aboard the sampling vessel and either taken to the transload site via a skiff or containerized at an uplands location within the project area. All disposable sampling materials and PPE used in sample processing will be placed in heavy duty garbage bags or other appropriate containers and disposed of as trash in the municipal collection system.

If taken to the uplands for disposal, sediment will be temporarily containerized in 55-gallon drums approved by Washington State Department of Transportation pending profiling and disposal. Each container holding IDW will be sealed and labeled with its contents (e.g., “sediments”), the dates on which the wastes were placed in the container, the owner’s name, contact information of the field person generating the waste, the site name, and the sample location(s) from which they were obtained or extracted. The drums will be left in Port custody until disposal is coordinated.

This page intentionally left blank.

6.0 Chemical Laboratory Analyses and Data Quality Objectives

This section describes the laboratory analytical protocols and QA objectives for post-dredge confirmation sampling. These QA objectives are consistent with the Quality Assurance Project Plan (QAPP) for the Pier 4 Removal Site Evaluation.

6.1 ANALYSIS PROGRAM

The analysis program for this project has been developed to evaluate the chemical quality of surface sediments in the dredge prism and perimeter areas after dredging. This analysis will determine whether the Phase 1 Removal Action has achieved the cleanup goals; furthermore, analysis will also inform the suitability determination for additional sediments that will be dredged during the Phase 2 Project. Chemical analysis of the samples will consist of bulk sediment TBT according to PSEP and DMMP analytical requirements, using the Krone method. Samples will be analyzed with an expedited turnaround time in order to minimize the duration of time that the dredge prism remains open and to minimize contractor stand-by time.

The DMMP SL TBT in bulk sediment is 73 $\mu\text{g}/\text{kg}$.

6.2 LIMITS OF DETECTION

The target detection limit for TBT bulk sediment analysis by the Krone method is 3.86 $\mu\text{g}/\text{kg}$.

The bulk sediment TBT reporting limit is significantly less than the DMMP SL of 73 $\mu\text{g}/\text{kg}$. Therefore, the method reporting limit will adequately demonstrate whether the objectives of the Phase 1 Removal Action have been met.

6.3 QUALITY ASSURANCE/QUALITY CONTROL

The chemistry QA/QC procedures will follow PSEP and the QA/QC criteria established for the Puget Sound Dredged Disposal Analysis and DMMP programs.

Surrogates will be required for every sample, including MS samples, blanks, laboratory control samples (LCS), and standard reference materials. MS/MSDs will be required for every 20 samples received. Matrix triplicates are analyzed for conventional parameters.

All samples will be diluted and re-analyzed if target compounds are detected at levels that exceed their respective established calibration ranges. Any cleanups will be conducted prior to the dilutions. Re-analyses will be performed if surrogate, internal standard, or spike recoveries are outside of the DQO parameters. QC samples may be re-analyzed if results are not within control limits and it cannot be determined that the sample matrix is the cause.

The DQOs for TBT analysis by the Krone method area as follows:

- Precision of ± 50 percent relative percent difference between MS and MSD concentrations.
- Accuracy of 50 to 150 percent recovery of MS concentrations.
- Completeness of 95 percent of results determined to be valid.

6.4 LABORATORY WRITTEN REPORT

A written laboratory report will be prepared by the analytical laboratory documenting all the activities associated with sample analyses. At a minimum, the following will be included in the report:

- Project analytical narrative.
- Results of the laboratory analyses, QA/QC results, and data validation.
- All protocols used during analyses.
- Chain-of-custody information including explanation of any deviation from those identified herein.
- Any protocol deviations from the approved sampling plan.
- Location and availability of data.
- References to protocol descriptions in this Post-Dredge Confirmational Sampling Plan, as appropriate.

7.0 Data Validation and Reporting

7.1 DATA VALIDATION

A QA1/Stage 2B Data Quality Review (Summary Validation) will be performed on all data by EcoChem as described below. However, in order to expedite decision-making during dredging, Floyd|Snider will perform a compliance screening review of the preliminary laboratory reports and disseminate this preliminary data to the USEPA prior to data validation by EcoChem. The QA1/Stage 2B Data Quality Review will evaluate the following:

- Evaluation of package completeness.
- Verification that sample numbers and analyses match those requested on the chain-of-custody form.
- Review of method-specified preservation and sample holding times.
- Verification that the required detection limits and reporting limits have been achieved.
- Verification that the field duplicates, MS/MSDs, and LCSs were analyzed at the proper frequency.
- Verification of analytical precision and accuracy via replicate analysis and analyte recoveries.
- Verification that the surrogate compound analyses have been performed and meet QC criteria.
- Verification that the laboratory method blanks are free of contaminants.
- Review of instrument performance—initial calibration, continuing calibration, tuning, sensitivity, and degradation.

Data validation will be based on the QC criteria as recommended in the methods identified in this Post-Dredge Confirmational Sampling Plan and in the *National Functional Guidelines for Organic and/or Inorganic Data Review* (USEPA 2008 and 2010).

Data usability, conformance with the DQOs, and any deviations that may have affected the quality of the data, as well as the basis of application of qualifiers, will be included in the final reporting of the data. Any required corrective actions based on the evaluation of the analytical data will be determined by the Analytical Resources, Inc. Project Manager and EcoChem. Project Manager in consultation with the Floyd|Snider QA Manager and may include qualification or rejection of the data.

7.2 PRELIMINARY DATA REPORTING TO USEPA

As described in Section 7.1 above, Floyd|Snider will perform a compliance screening review of preliminary laboratory data reports for internal consistency, transmittal errors, laboratory

protocols, and adherence to the DQOs as specified in this section. These preliminary data will be tabulated, and both pdf laboratory reports and preliminary data tables will be transmitted to the USEPA within 24 hours of receipt. These preliminary data will be used to determine whether the objectives of the Phase 1 Removal Action have been met.

7.3 FINAL REPORTING

Validated data will be tabulated and included in the Time Critical Removal Action Report. Final laboratory data pdf reports and data validation reports will also be included in this report.

8.0 References

- Bridges, T.S., K.E. Gustavson, P. Schroeder, S.J. Ells, D. Hayes, S.C. Nadeau, M.R. Palermo, and C. Patmont. 2010. *Dredging Processes and Remedy Effectiveness: Relationship to the 4 Rs of Environmental Dredging*. Integrated Environmental Assessment and Management. 10 February.
- Floyd|Snider. 2014a. *Pier 4 Phase 1 Removal Action Project Removal Site Evaluation Report*. Prepared for Port of Tacoma. 25 September.
- _____. 2014b. Memorandum re: Proposed Suitability of the Pier 4 Phase 1 Removal Action Project Material.
- Meador, James P. 2000. *An analysis in support of a sediment quality threshold for tributyltin to protect prey species for juvenile salmonids listed by the Endangered Species Act*. Northwest Fisheries Science Center, NOAA. 3 August.
- Palmero, Michael R., Paul R. Schroeder, Trudy J. Estes, and Norman R. Francingues. 2008. *Technical Guidelines for Environmental Dredging of Contaminated Sediments*. Produced by the U.S. Army Corps of Engineers. September.
- Puget Sound Estuary Program (PSEP). 1986. *Recommended protocols for measuring conventional sediment variables in Puget Sound*. Prepared for the Puget Sound Estuary Program, U.S. Environmental Protection Agency, Region 10, Office of Puget Sound, Seattle, Washington. Updated in 1989, 1991, 1995, and 1997.
- U.S. Army Corps of Engineers (USACE). 2013. *Dredged Material Evaluation and Disposal Procedures (User's Manual)*. Dredged Material Management Program: U.S. Army Corps of Engineers, Seattle District; U.S. Environmental Protection Agency, Region 10; Washington State Department of Natural Resources; Washington State Department of Ecology. July.
- U.S. Environmental Protection Agency (USEPA). 1989. "Methods for Evaluating the Attainment of Cleanup Standards, Volume 1: Soils and Solids Media." EPA 230/02-89-042. February.
- _____. 1996. *Soil Screening Guidance: Technical Background Document*. Second Edition. EPA/540/R95/128. Office of Solid Waste and Emergency Response. May.
- _____. 2008. *National Functional Guidelines for Organic Data Review*. EPA-540-R-08-01. June.
- _____. 2010. *National Functional Guidelines for Inorganic Data Review*. EPA 540-R-10-011. January.

**Pier 4 Phase 1 Removal
Action Project**

Removal Action Work Plan

**Appendix A
Post-Dredge Confirmational Sampling Plan
and Associated Health and Safety Plan**

Tables

Table A.1
Post-Dredge Confirmational and Perimeter Sampling and Analysis Scheme

Sampling Area	Sediment Grab Locations	Confirmational Samples (0–10 cm)	Shallow Subsurface Samples (10–20 cm)	Samples for Analysis	TBT Criteria Comparison	
					Screening Level/Action Levels	Criteria
Post-Dredge Confirmational Sampling						
Non-Hot Spot Dredge Area	14	14	14	28	Bulk Sediment SL ¹	73 µg/kg
Central Hot Spot Area	2	2	--	4	Bulk Sediment SL ¹	73 µg/kg
					Project Action Level ²	219 µg/kg
Southern Hot Spot Area	1	1	--	1	Bulk Sediment SL ¹	73 µg/kg
					Project Action Level ²	219 µg/kg
Perimeter Sampling						
Perimeter Sampling Areas	22	22	--	22	Bulk Sediment SL ¹	73 µg/kg
					Project Action Level ²	219 µg/kg
Potential Discretionary Perimeter Sampling Areas ³	5	5	--	5	Bulk Sediment SL ¹	73 µg/kg
					Project Action Level ²	219 µg/kg

Notes:

- 1 Previous versions of the DMMP User Manual, which were available when project SLs were determined in April 2013, listed 73 µg/kg as both the DMMP bulk sediment TBT SL and BT. Therefore the project SL for bulk TBT is 73 µg/kg.
- 2 The Project Action Level is equal to three times the bulk TBT SL.
- 3 Up to five additional discretionary perimeter samples may be added in coordination with USEPA based on the results of the post-dredge confirmational sampling results within the hot spot areas and/or water quality monitoring results during dredging.

Abbreviations:

- BT Bioaccumulation trigger
- cm Centimeter
- DMMP Dredged Material Management Program
- µg/kg Micrograms per kilogram
- SL Screening level
- TBT Tributyltin
- USEPA U.S. Environmental Protection Agency

Removal Action Work Plan

Appendix A: Post-Dredge Confirmational Sampling Plan

Table A.1

Table A.2
Analytical Requirements, Methods, Preservation, Bottle Type, and Holding Times

Analysis	Method	Bottle Type	Preservative	Holding Time
Tributyltin (Bulk)	Krone	One 8-oz WMG	None, cool to 4 ± 2 °C	14 days to extract, then 40 days to analyze, or freeze for 1 year
Tributyltin (Total Aqueous-Rinsate Blank)	Krone	One 250-mL Polycarbonate	None, cool to 4 ± 2 °C	7 days to extract, then 40 days to analyze

Abbreviations:

- AG Amber glass
- mL Milliliter
- oz Ounce
- WMG Wide-mouth glass jar

**Pier 4 Phase 1 Removal
Action Project**

Removal Action Work Plan

**Appendix A
Post-Dredge Confirmational Sampling Plan
and Associated Health and Safety Plan**

Figures



Blair Waterway

Pier 4

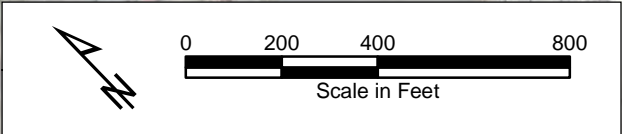

Notes:
 - Pier 4 location based on KPFF data.
 - Background aerial imagery provided by Esri, August 1, 2011.



FLOYD | SNIDER
 strategy • science • engineering

**Removal Action Work Plan
 Pier 4 Phase 1 Removal Action Project
 Tacoma, Washington**

Figure A.1
 Site Location Map of Pier 4

- Notes:
1. Dredge elevations shown do not include overdredge allowance.
 2. Dredge cut thicknesses shown do not include overdredge allowance.
 3. Provided by Hart Crowser, Inc.
- * Indicates a DMMU composite sample result. Result shown for the Sample Location B1, B2, and B3 composite is a TBT concentration in porewater (in $\mu\text{g/L}$) and is less than the DMMP porewater screening level of $0.15 \mu\text{g/L}$.
- All field locations are actual locations as measured on-site during the sampling events.
 - Existing and proposed Pier 4 locations provided by KPFF.
 - Bathymetric contour data provided by Port of Tacoma.
 - Background aerial imagery provided by Esri, 2011.

- Abbreviations:
- bgs = Below ground surface
 - bml = Below mudline
 - DMMP = Dredged Material Management Program
 - DMMU = Dredged Material Management Unit
 - ft = Feet
 - MLLW = Mean lower low water
 - $\mu\text{g/kg}$ = Micrograms per kilograms
 - $\mu\text{g/L}$ = Micrograms per liter
 - OHWM = Ordinary High Water Mark
 - TBT = Tributyltin

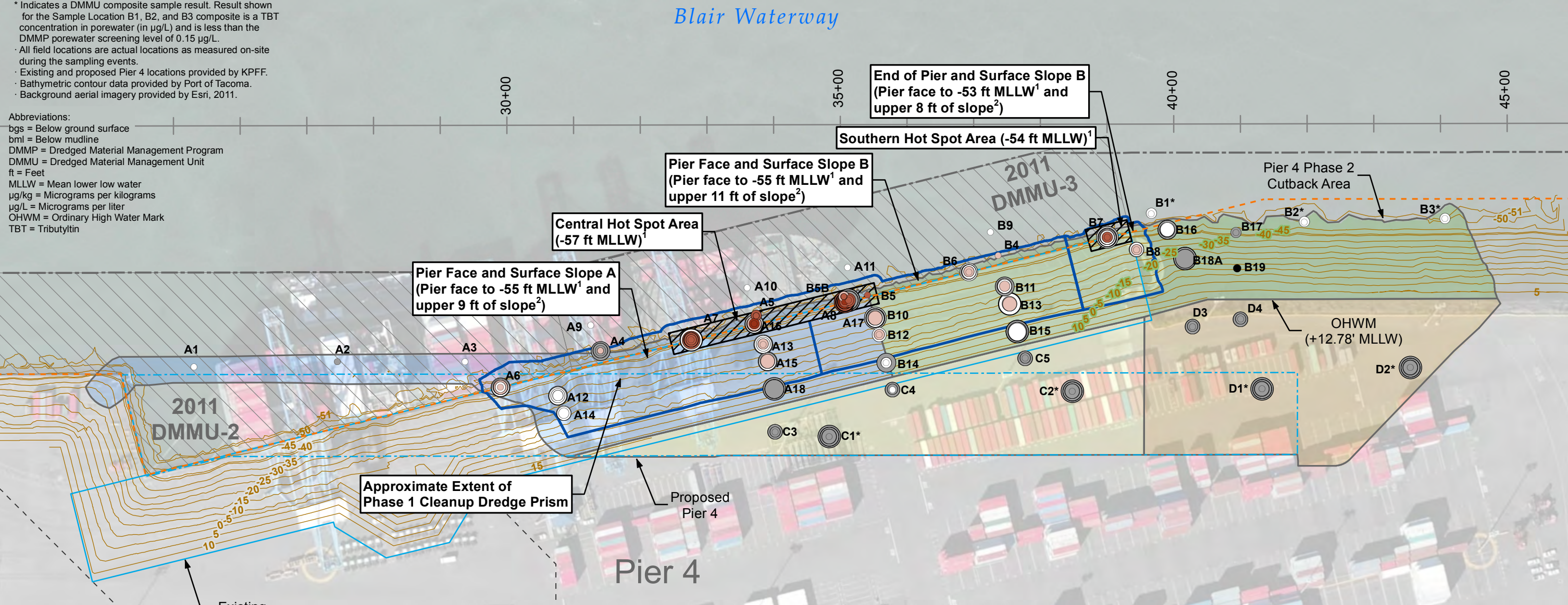

Legend

<p>TBT Concentration ($\mu\text{g/kg}$)</p> <ul style="list-style-type: none"> ○ 0–73 ○ 74–1,000 ○ 1,001–1,300 ○ 1,301–10,000 ○ 10,001–50,000 ● Analyte was not Detected at the Given Reporting Limit ● No Data (sample not analyzed) 	<p>Sample Depth (bml or bgs)</p> <ul style="list-style-type: none"> ○ ≤ 2 ft (surface sample) ○ 2–4 ft ○ 4–6 ft ○ 6–10 ft ○ > 10 ft 	<ul style="list-style-type: none"> --- Location of Former Slip³ — Station Reference Line - - - Pierhead Line - - - Channel Line ~ 2012 Post-Dredge Bathymetric Contour in Feet MLLW 	<ul style="list-style-type: none"> In-Water DMMU Area A In-Water DMMU Area B Cutback DMMU Area C Cutback DMMU Area D Anchor QEA 2012 DMMU-2 Boundary Proposed Pier 4 Existing Pier 4
--	--	---	---

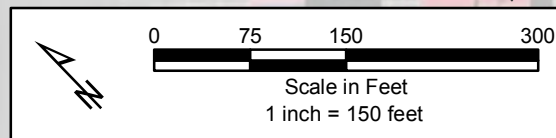

**Removal Action Work Plan
Pier 4 Phase 1 Removal Action Project
Tacoma, Washington**

Figure A.2
Phase 1 Dredge Areas and Design Dredge Cut Thicknesses

- Notes:
1. Dredge elevations shown do not include overdredge allowance.
 2. Volume is approximate and includes the 1-foot overdredge allowance.
 3. Provided by Hart Crowser, Inc.
 - Existing and proposed Pier 4 locations provided by KPFF.
 - Bathymetric contour data provided by Port of Tacoma.
 - Background aerial imagery provided by Esri, August 1, 2011.

- Abbreviations:
- CY = Cubic yards
 - ft = Feet
 - MLLW = Mean lower low water
 - OHWM = Ordinary High Water Mark
 - TBT = Tributyltin

Blair Waterway

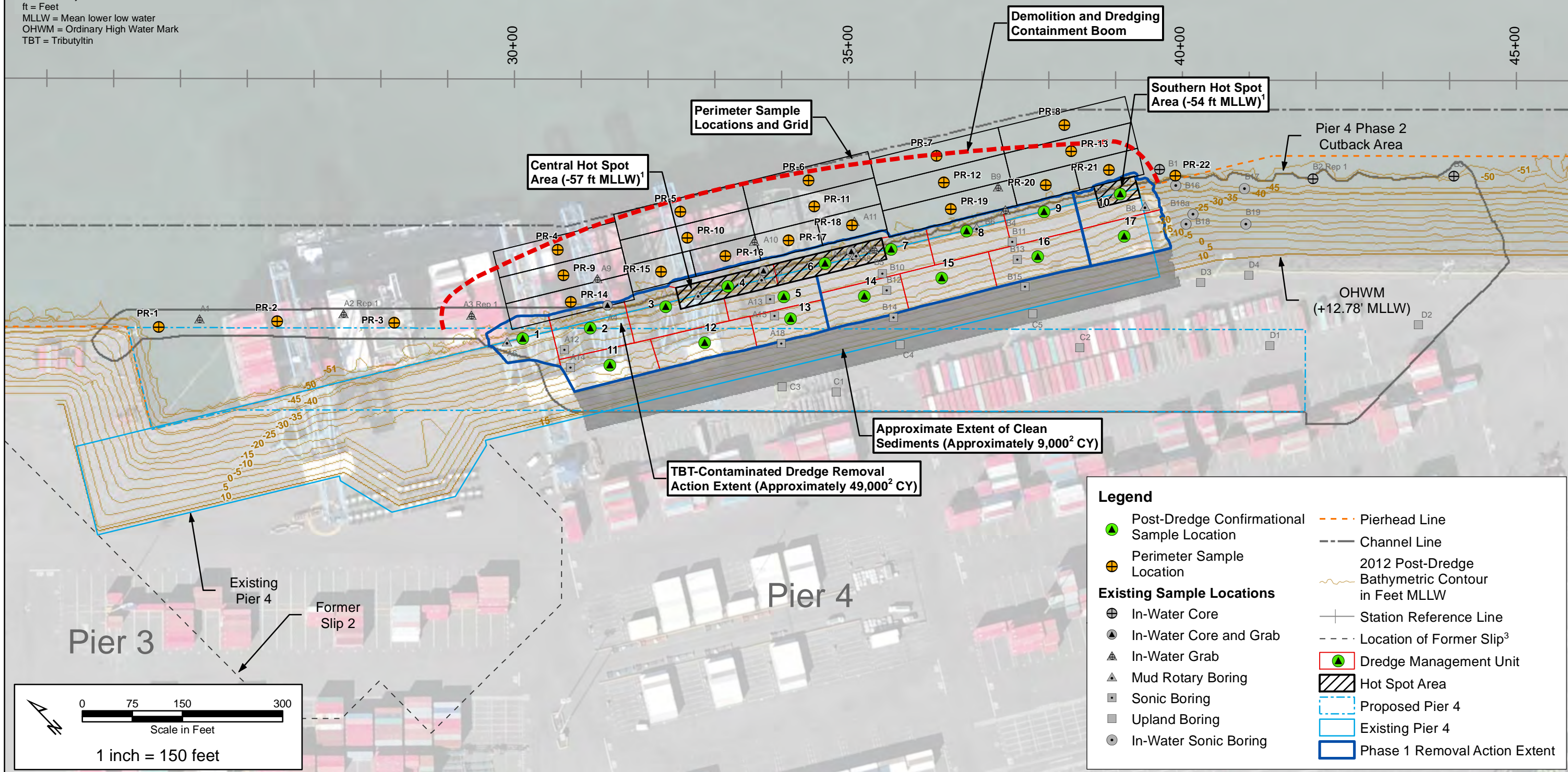

Legend

- Post-Dredge Confirmational Sample Location
- Perimeter Sample Location
- ⊕ In-Water Core
- ⊕ In-Water Core and Grab
- ⊕ In-Water Grab
- ⊕ Mud Rotary Boring
- Sonic Boring
- Upland Boring
- ⊕ In-Water Sonic Boring
- - - Pierhead Line
- - - Channel Line
- 2012 Post-Dredge Bathymetric Contour in Feet MLLW
- ⊕ Station Reference Line
- - - Location of Former Slip³
- Dredge Management Unit
- ▨ Hot Spot Area
- - - Proposed Pier 4
- - - Existing Pier 4
- - - Phase 1 Removal Action Extent



**Removal Action Work Plan
Pier 4 Phase 1 Removal Action Project
Tacoma, Washington**

**Figure A.3
Post-Dredge Confirmational Sample
and Perimeter Sample Locations**

**Pier 4 Phase 1 Removal
Action Project**

Removal Action Work Plan

**Appendix A
Post-Dredge Confirmational Sampling Plan
and Associated Health and Safety Plan**

**Attachment A.1
Contractor Signature Sheet**

Contractor Signature Sheet

Pier 4 Phase 1 Removal Action Project, Blair Waterway, Tacoma, Washington

By signing below, I acknowledge that I have reviewed the Post-Dredge Confirmational Sampling Plan and agree to follow the methods and quality assurance procedures contained therein.

Jessi Massingale, PE
Project Manager
Floyd|Snider
Date_____

Erin Murray
QA Manager
Floyd|Snider
Date_____

Kelly Bottem
Chemist
Analytical Resources, Inc. Project Manager
Date_____

Christine Ransom
Data Validation
EcoChem Project Manager
Date_____

Bill Gardner
Senior Toxicologist
Newfields Project Manager
Date_____

**Pier 4 Phase 1 Removal
Action Project**

Removal Action Work Plan

**Appendix A
Post-Dredge Confirmational Sampling Plan
and Associated Health and Safety Plan**

**Attachment A.2
Dredge Residuals Evaluation**

Attachment A.2 Dredge Residuals Evaluation

INTRODUCTION

This evaluation provides an estimate of the quantity and quality of dredging residuals that can be expected to be generated during dredging in areas within the Pier 4 Phase 1 Removal Action Project (Phase 1 Removal Action) dredge prism.

The purpose of this evaluation is to provide dredge residuals information to inform the scope of the removal action dredge approach as well as to support the scope of post-dredge confirmational sampling. The objectives of the post-dredge confirmational sampling are to provide sufficient analytical data to (1) confirm that the removal action achieves the project objectives and removal action completion requirements, and (2) confirm that the underlying sediment that is within the Pier 4 Phase 2 Reconfiguration Project (Phase 2 Project) dredge prism is suitable for either open-water disposal or beneficial use.

The expected dredge residuals thickness and concentrations of tributyltin (TBT) were calculated for areas within the dredge prism that include variable dredge cut thicknesses along the slope, as well as for the proposed hot spot areas, as presented and approved by the U.S. Environmental Protection Agency (USEPA) in the Removal Site Evaluation Report (Floyd|Snider 2014) and Figure A.2 of the Post-Dredge Confirmational Sampling Plan. The dredge cut thicknesses are based on the measured vertical thicknesses of TBT-contaminated sediments during the 2013 and 2014 site characterization events and are described in the RSER (Floyd|Snider 2014). Expected dredge residuals were calculated for the hot spot areas separately from the surrounding slope areas due to the differences in order of magnitude of the TBT sediment concentrations within the hot spots and because the proposed approach to manage dredge residuals within the hot spot areas differs from the rest of the dredge prism. Additionally, the Phase 1 cleanup and residuals management within the hot spot areas includes dredging to an elevation that is deeper than and outside of the Phase 2 Project dredge prism. Therefore, following the completion of the Phase 1 Removal Action, no additional dredging will be conducted within the central and southern hot spot areas. The dredging depth within the hot spot areas is well into native material, confirmed to be clean based on the sediment characterization results. This acts to manage dredge residuals that may be present as a thin layer on the underlying native material.

The dredge residuals calculations described below provide an estimation of the potential thickness and concentrations of dredge residuals that may be present within subareas of the Phase 1 dredge prism, including those located along the slope and the two hot spot areas.

DREDGE RESIDUALS CALCULATION METHODOLOGY

The calculation of dredge-generated residuals was carried out in accordance with Chapter 7 of the *Technical Guidelines for Environmental Dredging of Contaminated Sediments* (Palermo et al.

2008) using a multi-pass dredge approach. The parameters used for the calculations and their sources and values are presented in Table A.2.1.

The dredge prism was divided into five areas based on the designed dredge cut thicknesses along the slope (three areas) and hot spots (two areas) to determine representative TBT concentrations for use in the calculations. The hot spots (the central hot spot and the southern hot spot) were evaluated separately. The sampling locations used to generate the 95 percent upper confidence limit concentration for each area are presented in Table A.2.2.

The total dredge depth for each area was divided into two passes: Pass 1 was defined as a production pass, and Pass 2 was defined as a cleanup Pass.¹ An additional third pass (Pass 3) was evaluated for the hot spot areas. The total dredge depths were based on the dredge cuts for each area—the thickness required to remove all TBT-contaminated sediment, as well as the proposed approach of conservatively increasing the dredge prism depth into material confirmed to be clean per existing sampling results—resulting in an additional 1 to 2 feet of clean material being dredged with the overlying TBT-contaminated sediments, as well as an over-dredge allowance of 1 foot. An additional third pass consisting of approximately 1 foot was evaluated within the hot spot areas to reduce the generated residuals TBT concentration expected to remain on the post-dredge surface. This results in the central hot spot area being dredged to a minimum elevation of -57 feet mean lower low water (MLLW), approximately 3 feet into clean native material. The maximum allowable over-dredge will be 2 feet to account for equipment tolerance; therefore, the central hot spot may be dredged to a depth of -58 feet MLLW, which would further reduce the predicted dredge residuals TBT concentrations.

In most cases Pass 1 consisted only of TBT-contaminated material (with the exception of the southern hot spot, which consisted of 7 feet of contaminated material and 2 feet of clean material). Additionally, in most cases Pass 2 consisted of 3 feet of clean material (with the exception of the central hot spot, which consisted of 1 foot of contaminated material on top of 2 feet of clean material). Table A.2.2 presents the thicknesses of the clean and contaminated sediment in each area, and the thicknesses of each dredge pass.

For each pass, the sediment mass and mass of TBT are calculated for the contaminated and clean material individually, and then a composite sediment mass and the mass of TBT are calculated. If the entire pass is made up of only clean or contaminated material, the composite calculation was not needed.

$$\text{Sediment Mass} = \rho * L$$

$$\text{TBT Mass} = C * \text{Sediment Mass}$$

Where: ρ = the in situ dry density of target dredge material (kilograms per cubic meter [kg/m^3])
 L = the thickness of the production or cleanup pass (feet)
 C = the TBT concentration in the sediment ($\mu\text{g}/\text{kg}$)

¹ The production pass (Pass 1) conducted by the Contractor will likely consist of more than one lift or “bite” with the dredge bucket and will depend on the bucket size, slope conditions, and Contractor methodology.

Next, the sediment mass, TBT mass, TBT concentration, and thickness of the residuals layer resulting from the first pass is calculated based on the potential residuals loss percentage assumed. The residuals loss percentage assumed for the first pass was 7.5 percent; a higher level of loss that could be expected based on the presences of debris (i.e., riprap rock) within the first pass of the dredge prism (Bridges et al. 2008; Patmont and Palermo 2007).

$$\text{Residuals Layer Mass} = R * \rho * L$$

$$\text{Residuals Layer TBT Mass} = \text{Residuals Layer Mass} * C$$

$$\text{Residuals Layer TBT Concentration} = \frac{\text{Residuals Layer TBT Mass}}{\text{Residuals Layer Mass}}$$

$$\text{Residuals Layer Thickness} = \frac{\text{Residuals Layer Mass}}{\rho_R}$$

Where: R = the percent residuals loss

ρ = the in situ dry density of target dredge material (kg/m³)

L = the thickness of the production or cleanup pass (feet)

C = the TBT concentration in the sediment (µg/kg)

ρ_R = the in situ dry density of the residuals (kg/m³)

For the second pass, the composite sediment mass and TBT mass include the contaminated and/or clean portions of the sediment within Pass 2, and the residuals layer calculated to result from Pass 1 that has settled on top. The residuals loss percentage assumed for the second pass (and third pass within the hot spot areas) was 3.5 percent; a lower level of loss relative to the first pass since the riprap rock will be removed within the first pass (Bridges et al. 2008; Patmont and Palermo 2007).

Composite Sediment Mass

$$\begin{aligned} &= \text{Pass 2 Contaminated Sediment Mass} \\ &+ \text{Pass 2 Clean Sediment Mass} \\ &+ \text{Pass 1 Residuals Layer Mass} \end{aligned}$$

Composite TBT Mass

$$\begin{aligned} &= \text{Pass 2 Contaminated TBT Mass} + \text{Pass 2 Clean TBT Mass} \\ &+ \text{Pass 1 Residuals Layer TBT Mass} \end{aligned}$$

Again, the sediment mass, TBT mass, TBT concentration, and thickness of the residuals layer resulting from Pass 2 and Pass 3 within the hot spot areas is calculated based on the potential residuals loss percentage assumed. This is the final dredge residuals layer that is left in place.

RESULTS

The results of the calculations are presented in Table A.2.3. The results presented in each area include the residuals layer thickness and TBT concentrations within the top 1 foot and the top 10 centimeters (cm) of the post-dredge surface. The dredge residuals evaluation includes the following results:

- Dredging residuals concentrations will be reduced in the short term (i.e., within a few weeks or months) following dredging, as the residuals re-consolidate to their original density. Following initial consolidation, the dredging residuals will occupy a proportionally smaller fraction of the top 10-cm biologically active zone, with the substrate becoming more stable and physically suitable for benthic colonization. Stable, long-term surface concentrations are expected to be 1.7 times to 2.6 times lower than the initial low-density condition as a result of short-term consolidation.
- Final (after the last dredge pass) residuals layer thicknesses ranged from 3.21 to 10.5 cm, with concentrations ranging from 15.3 to 278 $\mu\text{g}/\text{kg}$ (including the third pass within the hot spot areas).
- The greatest post-dredge residuals layer concentrations were predicted in the central hot spot area.
 - The predicted post-dredge residuals layer TBT concentration within the top 10 cm of the post-dredge surface following three passes in the central hot spot area was 278 $\mu\text{g}/\text{kg}$ based on a dredge residuals layer of approximately 3 cm.
 - Following consolidation of the residuals layer over weeks to months following dredging, the predicted dredge residuals thickness is approximately 1 cm with a TBT sediment concentration of the top 10 cm of approximately 108 $\mu\text{g}/\text{kg}$.
 - Estimating the density of the low strength residuals layer to be 450 kg/m^3 and the density of the compacted residuals layer to be 1,200 kg/m^3 after the residuals are given the opportunity to compact and approach the in situ dry density of the target dredge material indicates that the residuals layer would compact to approximately 37.5 percent of its original thickness over time.
 - If the residuals were allowed to compact over time, the TBT concentration in the upper 10 cm would decrease (108 $\mu\text{g}/\text{kg}$ compared to 278 $\mu\text{g}/\text{kg}$), as a greater portion of the remaining 10 cm would be underlying, undisturbed clean material.
 - Therefore, in the central hotspot location, the sample interval thickness immediately after dredging that would be representative of the upper 10 cm after consolidation had occurred would be 12 cm.
- The predicted post-dredge residuals layer TBT concentration within the top 10 cm of the post-dredge surface following three passes in the southern hot spot area was 38 $\mu\text{g}/\text{kg}$.

- The predicted post-dredge residuals layers of the non-hot spot areas are less than the DMMP TBT SL of 73 µg/kg.
 - The predicted post-dredge residuals layer TBT concentrations within the top 10 cm of the post-dredge surface within non-hot spot areas range from 15.3 to 35 µg/kg.
 - The predicted post-dredge residuals layer TBT concentrations within the top 1 foot of the post-dredge surface within non-hot spot areas range from 8.4 to 14.9 µg/kg.

The results of the dredge residuals evaluation are also conservative because a 1-foot over-dredge allowance was assumed, rather than a 2-foot over-dredge allowance. An additional increment of up to 1 foot below the required dredge elevations will be payable to the Contractor to account for equipment tolerance on the Phase 1 Removal Action; however, the maximum allowable over-dredge is 2 feet below the required dredge elevation. If the maximum allowable over-dredge of 2 feet is executed, it would result in deeper dredging into clean and/or native material, and the predicted dredge residuals TBT concentrations would be less than those presented in this evaluation.

CONCLUSIONS

The results of the dredge residuals evaluation within the dredge prism, excluding the central hot spot area, indicate that the predicted post-dredge surface sediments within the top 10 cm are less than the DMMP SL; therefore, the proposed removal action dredge approach is anticipated to achieve the project objectives and removal action completion requirements. The thickness and TBT concentrations of expected dredge residuals will not adversely impact the surface quality of the post-dredge surface material that will be dredged as part of the Phase 2 Project.

Additionally, the average post-dredge residuals layer thickness of non-hot spot areas is approximately 0.3 feet, or approximately 10 cm. This average thickness over the non-hot spot area dredge footprint is, conservatively, approximately 450 cubic yards (CY). The post-dredge residuals layer is, therefore, less than 0.1 percent of the Phase 2 500,000 CY dredge material volume that will be dredged following the completion of the Phase 1 Removal Action.

The results of the dredge residuals evaluation within the two hot spot areas indicate that, due to the predicted TBT concentrations of expected dredge residuals, the performance of an additional approximately 1-foot third pass and the placement of 1 to 2 feet of clean material as backfill over the TBT central hot spot area, is an appropriate residuals management activity. By conducting a third pass of dredging within the southern hot spot area an exceedance of the DMMP SL of 73 µg/kg is not expected.

As documented by residuals measurements conducted during and following dredge projects, as well as within U.S. Army Corps of Engineers dredging guidance, resuspension, release, and residuals will occur if dredging is performed (Bridges et al. 2008). No removal technology can remove every particle of contaminated sediments, and field results for most projects show that post-dredging residuals contamination levels have often not met desired cleanup levels.

Dredge residuals are the contaminated sediment that can be expected to be found at the post-dredge surface, and are not representative of contaminated sediment that was missed or “missed inventory.” The proposed dredge cuts within the hot spot areas include conservatively increased dredge thicknesses, resulting in dredging into confirmed clean native material and an additional third pass.

TABLES

- Table A.2.1 Phase 1 Dredge Residuals Calculation Parameter Input Values
- Table A.2.2 Dredge Cut and Tributyltin-Contaminated Sediment Thicknesses by Area
- Table A.2.3 Results of Residuals Evaluation for Each Area within the Phase 1 Removal Action Dredge Prism

REFERENCES

- Bridges, Todd S., Stephen Ells, Donald Hayes, David Mount, Steven C. Nadeau, Michael R. Palermo, Clay Patmont, and Paul Schroeder. 2008. *The Four Rs of Environmental Dredging: Resuspension, Release, Residual, and Risk*. Prepared for the U.S. Army Corps of Engineers. ERDC\EL TR-08-4. February.
- Floyd|Snider. 2014. *Removal Site Evaluation Report*. Prepared for the Port of Tacoma. 12 September.
- Patmont, C. and M.R. Palermo, 2007. Case Studies of Environmental Dredging Residuals and Management Implications. Paper D-066, in: E.A. Foote and G.S. Durell (Conference Chairs), *Remediation of Contaminated Sediments—2007*. Proceedings of the Fourth International Conference on Remediation of Contaminated Sediments. Savannah, Georgia. January.
- Palermo, Michael R., Paul R. Schroeder, Trudy J. Estes, and Norman R. Francingues. 2008. *Technical Guidelines for Environmental Dredging of Contaminated Sediments*. Prepared for the U.S. Army Corps of Engineers. ERDC/EL TR-08-29. September.

**Pier 4 Phase 1 Removal
Action Project**

Removal Action Work Plan

**Appendix A
Post-Dredge Confirmational Sampling Plan
and Associated Health and Safety Plan**

**Attachment A.2
Dredge Residuals Evaluation**

Tables

Table A.2.1
Phase 1 Dredge Residuals Calculation Parameter Input Values

Parameter	Source	Input Value or Range
In situ dry density of target dredge material (ρ)	Density for the expected conditions based on dredge prism laboratory grain size distribution of primarily silty sands	1,200 kg/m ³
In situ dry density of residuals (ρ_R)	Density for the expected low strength residual layer and expected conditions (Palermo et al. 2008)	450 kg/m ³
Required dredge cut thickness	Results of the site sediment characterization events (Floyd Snider 2014)	8 to 11 feet
Residual loss (R)	Potential project loss range expected based on the presences of debris (i.e., riprap rock) within the first pass of the dredge prism and guidance documented ranges (Bridges et al. 2008; Patmont and Palermo 2007)	7.5% - first pass 3.5% - first pass
Depth of assumed allowable over-dredge ¹	Phase 1 payable over-dredge allowance	1 foot
Target TBT concentration (required values)	DMMP TBT screening level applied to the Pier 4 Phase 1 Removal Action Project	73 µg/kg
Thickness of production dredge passes ² (L_1)	Expected range of first pass based on the total required dredge cut thickness and expected contractor requirement of a 3-foot final production/cleanup dredge pass into confirmed clean material	6 to 9 feet
Thickness of final production/ cleanup dredge passes (L_2)	Required dredge cut thickness less the thickness of the initial production dredge pass	3 feet ³

Notes:

- 1 An additional increment of up to 1 foot below the required dredge elevations will be payable to the Contractor to account for equipment tolerance on the Phase 1 Removal Action; however, the maximum allowable over-dredge is 2 feet below the required dredge elevation. Conservatively, for this dredge residual evaluation the 1-foot payable over-dredge allowance was assumed. If the maximum allowable over-dredge of 2 feet is executed, this would result in deeper dredging into clean and/or native material, and the predicted dredge residual TBT concentrations would be less than those presented in this evaluation.
- 2 The thickness range of the production dredge pass (first pass) to be conducted during the dredging may consist of multiple lifts depending on the dredge bucket size and specific conditions of the dredge area (e.g., presence and thickness of rock armor, slope, etc.).
- 3 An additional third pass consisting of approximately 1 foot is proposed within the hot spot areas.

Abbreviations:

DMMP	Dredged Material Management Program	µg/kg	Micrograms per kilogram
kg/m ³	Kilograms per cubic meter	TBT	Tributyltin

**Table A.2.2
Dredge Cut and Tributyltin-Contaminated Sediment Thicknesses by Area**

Area	TBT 95 Percent Upper Confidence Limit (µg/kg)	Dredge Cut (ft) ¹	Allowable Overdredge (ft) ²	Total Dredge Cut (ft)	Contaminated Sediment Thickness (ft)	Clean Sediment Thickness (ft)	First Pass Thickness (ft)	Second Pass Thickness (ft)	Third Pass Thickness (ft)	Sampling Locations Used for Average TBT Concentration
Pier Face and Surface Slope A Without Hot Spot	207	9	1	10	7	3	7	3	--	A4, A4A, A6, A12, A13, A14, A15, A18
Pier Face and Surface Slope B Without Hot Spot	374	11	1	12	9	3	9	3	--	B4, B6, B10, B11, B12, B13, B14, B15
End of Pier and Surface Slope B Without Hot Spot	85	8	1	9	6	3	6	3	--	B8, B16
Central Hot Spot	16352	12	1	13	10	3	9	3	1	A5, A5A, A7, A8, A16, A17, B5, B5B
Southern Hot Spot	6360	12	1	13	7	6	9	3	1	B7

Notes:

- 1 The dredge cut as shown includes the thickness required to remove all TBT-contaminated sediment, as well as the proposed approach of conservatively increasing the dredge prism depth into material confirmed to be clean per existing sampling results. This approach results in an additional 1 to 2 feet of clean material being dredged with the overlying TBT-contaminated sediments.
- 2 An additional increment of up to 1 foot below the required dredge elevations will be payable to the Contractor to account for equipment tolerance on the Pier 4 Phase 1 removal Action Project. However, the maximum allowable overdredge is 2 feet below the required dredge elevation. Conservatively, for this dredge residual evaluation the 1 foot payable over-dredge allowance was assumed. If the maximum allowable overdredge of 2 feet is executed, this would result in deeper dredging into clean and/or native material, and the predicted dredge residual TBT concentrations would be less than those presented in this evaluation.

Abbreviations:

ft Feet
µg/kg Micrograms per kilogram
TBT Tributyltin

Table A.2.3
Results of Residuals Evaluation for Each Area within the Phase 1 Removal Action Dredge Prism

Dredging Area	Dredge Production (Pass 1) and Cleanup (Pass 2) Passes	R (%)	C (µg/kg)	ρ (kg/m ³)	L (ft)	Sediment		Composite		Residuals Layer			TBT Concentration of Top 1 ft Post-Dredge Surface (µg/kg)	TBT Concentration of Top 10 cm Post-Dredge Surface (µg/kg)	Compacted Thickness of Residuals (cm)	TBT Concentration of Top 10 cm Post-Compaction Dredge Surface (µg/kg)	Post-Dredge Thickness Representative of Consolidated Upper 10 cm Surface (cm)			
						Mass (kg-ft/m ³)	TBT Mass (µg-ft/m ³)	Mass (kg-ft/m ³)	TBT Mass (µg-ft/m ³)	Mass (kg-ft/m ³)	TBT Mass (µg-ft/m ³)	TBT Concentration (µg/kg)						Thickness ³ (ft)	Thickness (cm)	
Pier Face and Surface Slope A	Pass 1	7.5%	207	1200	7	--	--	--	--	630	130158	207	1.40	42.7	--	--	16.0	--	--	
	Pass 2 - contaminated	3.5%	207	1200	0	0	0													
	Pass 2 - clean material	3.5%	5	1200	3	3600	18000	4230	148158	148	5186	35	0.33	10.0	14.9	35.0	3.76	16.3	16.3	
Pier Face and Surface Slope B	Pass 1	7.5%	374	1200	9	--	--	--	--	810	302859	374	1.80	54.9	--	--	20.6	--	--	
	Pass 2 - contaminated	3.5%	374	1200	0	0	0													
	Pass 2 - clean material	3.5%	5	1200	3	3600	18000	4410	320859	154	11230	73	0.34	10.5	28.2	72.8	3.92	31.6	16.5	
End of Pier and Surface Slope B	Pass 1	7.5%	85	1200	6	--	--	--	--	540	45986	85	1.20	36.6	--	--	13.7	--	--	
	Pass 2 - contaminated	3.5%	85	1200	0	0	0													
	Pass 2 - clean material	3.5%	5	1200	3	3600	18000	4140	63986.4	145	2240	15	0.32	9.8	8.4	15.3	3.68	8.85	16.1	
Central Hot Spot ¹	Pass 1	7.5%	16352	1200	9	--	--	--	--	810	13245120	16352	1.8	54.9	--	--	20.6	--	--	
	Pass 2 - contaminated	3.5%	16352	1200	1	1200	19622400													
	Pass 2 - clean material	3.5%	5	1200	2	2400	12000	4410	32879520	154	1150783	7456	0.34	10.5	2561	7456	3.92	2926	16.5	
	Pass 3 - contaminated	3.5%	16352	1200	0	0	0													
	Pass 3 - clean material	3.5%	5	1200	1	1200	6000	1354	1156783	47	40487	854	0.11	3.21	94	278	1.20	107.2	12.0	
Southern Hot Spot ¹	Pass 1 - contaminated	7.5%	6360	1200	7	8400	53424000													
	Pass 1 - clean material	7.5%	5	1200	2	2400	12000	10800	53436000	810	4007700	4948	1.80	54.9	--	--	20.6	--	--	
	Pass 2 - contaminated	3.5%	6360	1200	0	0	0													
	Pass 2 - clean material	3.5%	5	1200	3	3600	18000	4410	4025700	154	140900	913	0.34	10.5	316.4	913	3.92	361	16.5	
	Pass 3 - contaminated	3.5%	6360	1200	0	0	0													
Pass 3 - clean material	3.5%	5	1200	1	1200	6000	1354	146900	47	5141	108	0.11	3.21	16	38	1.20	17.5	12.0		

Notes:

- C Indicates the TBT concentration in the sediment (µg/kg).
- R Indicates the percent residual loss.
- ρ Indicates the in situ dry density of target dredge material (kg/m³).
- L Indicates the thickness of the production or cleanup pass (feet).
- Indicates that the residual layer TBT concentration of the first pass was not compared to the DMMP SL because the second pass will occur following the first pass.
- Bold** Indicates residual layer thicknesses and TBT concentrations associated with the second and third passes.
- Gray shading indicates predicted FINAL dredge residual TBT concentrations that are greater than the DMMP SL of 73 µg/kg within the top 10 cm of sediment of the post-dredge surface.
- 1 It is proposed that in the hot spot areas 1 foot of sand is placed on top of the post-dredge surface to manage the calculated dredge residuals.
- 2 For the clean material associated with the dredge passes a TBT concentration of 5 µg/kg was used as an upper end of potential bulk sediment TBT reporting limit.
- 3 Assuming a residuals layer density of 450 kg/m³.

Abbreviations:

- cm Centimeters
- DMMP Dredged Material Management Plan
- ft Feet
- kg Kilograms
- µg Micrograms
- m³ Cubic meters
- TBT Tributyltin

**Pier 4 Phase 1 Removal
Action Project**

Removal Action Work Plan

**Appendix A
Post-Dredge Confirmational Sampling Plan
and Associated Health and Safety Plan**

**Attachment A.3
Sediment Sampling Health and Safety Plan**

LIMITATIONS

This report has been prepared for the exclusive use of the Port of Tacoma, their authorized agents, and regulatory agencies. It has been prepared following the described methods and information available at the time of the work. No other party should use this report for any purpose other than that originally intended, unless Floyd|Snider agrees in advance to such reliance in writing. The information contained herein should not be utilized for any purpose or project except the one originally intended. Under no circumstances shall this document be altered, updated, or revised without written authorization of Floyd|Snider.

The interpretations and conclusions contained in this report are based in part on site characterization data collected by others. Floyd|Snider cannot assure the accuracy of this information.

Table of Contents

1.0 Plan Objectives and Applicability 1-1

2.0 Background 2-1

 2.1 SITE BACKGROUND 2-1

 2.2 SCOPE OF WORK 2-1

3.0 Emergency Contacts and Information 3-1

 3.1 DIAL 911 3-1

 3.2 HOSPITAL AND POISON CONTROL 3-1

 3.3 PROVIDE INFORMATION TO EMERGENCY PERSONNEL 3-2

 3.4 FLOYD|SNIDER AND PORT EMERGENCY CONTACTS 3-3

4.0 Primary Responsibilities and Requirements 4-1

 4.1 PROJECT MANAGER 4-1

 4.2 HEALTH AND SAFETY OFFICER AND SITE SUPERVISOR 4-1

 4.3 SITE SAFETY OFFICER 4-1

 4.4 FLOYD|SNIDER PROJECT PERSONNEL 4-2

 4.5 TRAINING REQUIREMENTS 4-2

5.0 Hazard Evaluation and Risk Analysis 5-1

 5.1 CHEMICAL EXPOSURE HAZARDS 5-1

 5.2 FIRE AND EXPLOSION HAZARDS 5-1

 5.3 PHYSICAL HAZARDS 5-2

 5.3.1 Cold Stress 5-5

 5.3.2 Heat Stress 5-7

 5.3.3 Biohazards 5-9

 5.3.4 Traffic Hazards 5-9

6.0 Site Monitoring 6-1

 6.1 SITE MONITORING 6-1

7.0 Hazard Analysis by Task 7-1

8.0 Personal Protective Equipment 8-1

9.0 Site Control and Communication 9-1

 9.1 SITE CONTROL 9-1

9.2	COMMUNICATION	9-1
10.0	Decontamination and Waste Disposal.....	10-1
10.1	DECONTAMINATION	10-1
10.2	WASTE DISPOSAL	10-1
11.0	Emergency Response and Contingency Plan.....	11-1
11.1	MEDICAL EMERGENCIES	11-1
11.2	ACCIDENTAL RELEASE OF HAZARDOUS MATERIALS OR WASTES.....	11-2
11.3	GENERAL EMERGENCIES	11-2
11.4	EMERGENCY COMMUNICATIONS.....	11-2
11.5	EMERGENCY EQUIPMENT	11-3
12.0	Administrative	12-1
12.1	MEDICAL SURVEILLANCE	12-1
12.2	RECORDKEEPING	12-1
13.0	Approvals.....	13-1
14.0	Signature Page	14-1

List of Figures

- Figure 3.1 Hospital Directions
Figure 3.2 Pier 4 Site

List of Attachments

- Attachment 1 Daily Tailgate Safety Meeting and Debrief Form

List of Abbreviations and Acronyms

Acronym/ Abbreviation	Definition
AOC	Agreed Order on Consent
DMMP	Dredged Material Management Program
GCP	General Central Peninsula
HASP	Health and Safety Plan
HAZWOP	Hazardous Waste Operations

Acronym/ Abbreviation	Definition
HSO	Health and Safety Officer
µg/kg	Micrograms per kilogram
OSHA	Occupational Safety and Health Act
PFD	Personal flotation device
PM	Project Manager
Port	Port of Tacoma
PPE	Personal protective equipment
SS	Site Supervisor
SSO	Site Safety Officer
TBT	Tributyltin
TSA	Transportation Security Administration
USEPA	U.S. Environmental Protection Agency
WAC	Washington Administrative Code

1.0 Plan Objectives and Applicability

This Health and Safety Plan (HASP) has been written to comply with the standards prescribed by the Occupational Safety and Health Act (OSHA) and the Washington Industrial Safety and Health Act.

This HASP supports a sampling effort being undertaken as a U.S. Environmental Protection Agency (USEPA) Emergency Action in coordination with the Port of Tacoma (Port) and the Dredged Material Management Program (DMMP). It is presented as Attachment 1 to the Post-Dredge Confirmational Sampling Plan, which will be fulfilled as part of the Removal Action Work Plan for the Pier 4 Phase 1 Removal Action Project (Phase 1 Removal Action). The purpose of this HASP is to establish protection standards and mandatory safe practices and procedures for all personnel involved post-dredge confirmation sampling activities, which are assumed to include sediment grab collection at Pier 4. This HASP assigns responsibilities, establishes standard operating procedures, and provides for contingencies that may occur during field work activities. This plan consists of site descriptions, a summary of work activities, an identification and evaluation of chemical and physical hazards, monitoring procedures, personnel responsibilities, a description of site zones, decontamination and disposal practices, emergency procedures, and administrative requirements.

The provisions and procedures outlined by this HASP apply to all Floyd|Snider personnel on-site. Contractors, subcontractors, other oversight personnel, and all other persons involved with the field work activities described herein are required to develop and comply with their own HASP. All Floyd|Snider staff conducting field activities are required to read this HASP and indicate that they understand its contents by signing the Health and Safety Officer/Site Supervisors' (HSO/SS') copy of this plan.

It should be noted that this HASP is based on information that was available as of the date indicated on the title page. It is possible that additional hazards that are not specifically addressed by this HASP may exist at the work site, or may be created as a result of on-site activities. It is the firm belief of Floyd|Snider that active participation in health and safety procedures and acute awareness of on-site conditions by all workers is crucial to the health and safety of everyone involved. Should project personnel identify a site condition that is not addressed by this HASP and have any questions or concerns about site conditions, they should immediately notify the HSO/SS and an addendum will be provided to this HASP.

The HSO/SS has field responsibility for ensuring that the provisions outlined herein adequately protect worker health and safety and that the procedures outlined by this HASP are properly implemented. In this capacity, the HSO/SS will conduct regular site inspections to ensure that this HASP remains current with potentially changing site conditions. The HSO/SS has the authority to make health and safety decisions that may not be specifically outlined in this HASP, should site conditions warrant such actions. In the event that the HSO/SS leaves the site while work is in progress, an alternate Site Safety Officer (SSO) will be designated. Personnel responsibilities are further described in Section 4.0.

This HASP has been reviewed by the Project Manager (PM) and the HSO/SS prior to commencement of work activities. All Floyd|Snider personnel shall review the plan and be familiar with on-site health and safety procedures. A copy of the HASP will be on-site at all times.

2.0 Background

2.1 SITE BACKGROUND

The Port is in the process of design and permitting for the reconfiguration of the General Central Peninsula (GCP) complex, which consists of aligning Pier 4 with Pier 3 within the Husky Container Terminal. The GCP is situated on the west side of the northern portion of the Blair Waterway. The Blair Waterway is located within the Port's Industrial Development District, which is adjacent to Commencement Bay and within the City of Tacoma. Prior to the 1920s, the site of the GCP was filled and dredged to create two ship slips at the north and south ends of the current pier location, Slips 1 and 2, respectively. The existing Pier 3 wharf was constructed in 1988. This project included dredging the slope adjacent to the waterway, filling the south slip (Slip 2), constructing Pier 3, and extending Pier 4 to connect with Pier 3. Routine maintenance dredging of Pier 3 and Pier 4 was last completed in 2011.

During DMMP sampling at Pier 4 to support redevelopment, tributyltin (TBT) contamination was discovered in sediments at the pier face and under the pier. In consultation with USEPA and the DMMP representatives, and based on the TBT concentrations detected at Pier 4, the Port entered into an agreed order on consent (AOC) with USEPA in June 2014. The redevelopment at Pier 4 is planned to take place in two phases under the AOC, including the Phase 1 Removal Action and Phase 2 Reconfiguration Project. The Removal Action Work Plan outlines the activities that will be undertaken to remove contaminated sediments during the Phase 1 Removal Action. This HASP supports the Post-Dredge Confirmational Sampling Plan, which will be implemented as part of the Phase 1 Removal Action.

The Pier 4 project area is currently an active shipping berth with an over-water pier and container cranes. However, post-dredge confirmation sampling will occur after pier demolition and the project area at this time will consist of an in-water dredge area with an uplands concrete bulkhead.

2.2 SCOPE OF WORK

This HASP focuses on field activities associated with sediment sampling as described in the Post-Dredge Confirmational Sampling Plan. Floyd|Snider will conduct sediment grabs to fulfill the sampling plan.

3.0 Emergency Contacts and Information

3.1 DIAL 911

In the event of any emergency, dial 911 to reach fire, police, and first aid.

3.2 HOSPITAL AND POISON CONTROL

<p>Nearest Hospital Location and Telephone: Refer to Figure 1 below for map and directions to the hospital.</p>	<p>St. Joseph Medical Center 1717 South J Street Tacoma, WA 98405 (253) 426-4101</p>
<p>Washington Poison Control Center:</p>	<p>(800) 222-1222</p>

**Figure 3.1
Hospital Directions**

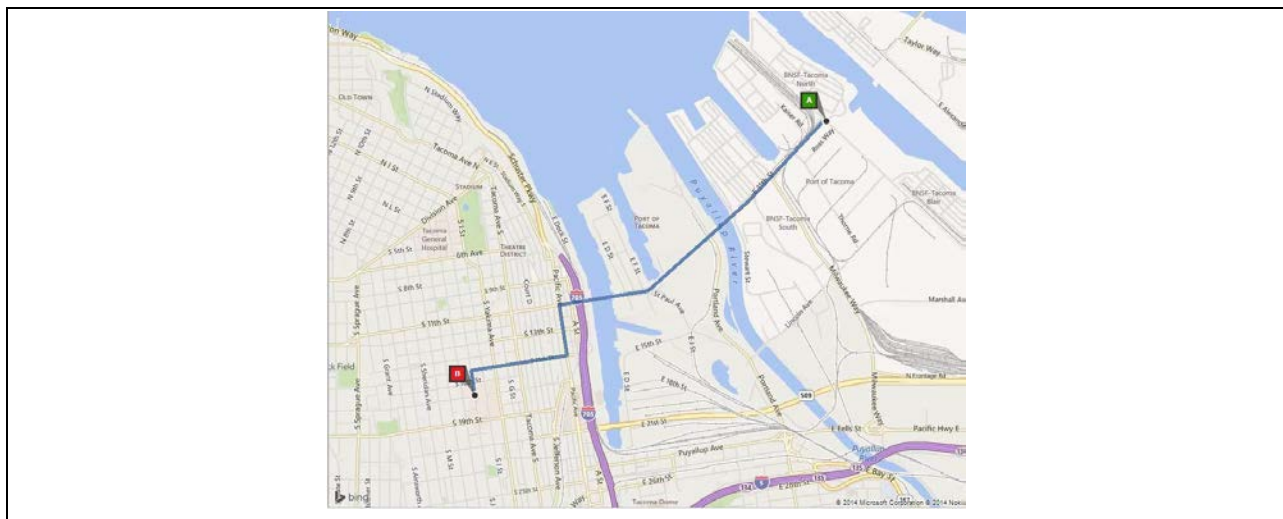

1. Leave site heading **NORTHWEST** on **PORT OF TACOMA ROAD**
2. Turn **LEFT** onto **EAST 11TH STREET**
3. Turn **LEFT** onto **PACIFIC AVENUE**
4. Turn **RIGHT** onto **SOUTH 15TH STREET**
5. Turn **LEFT** onto **SOUTH J STREET**
6. Turn **LEFT** into **ST JOSEPH MEDICAL CENTER EMERGENCY SERVICES ENTRANCE**

3.3 PROVIDE INFORMATION TO EMERGENCY PERSONNEL

All Floyd|Snider project personnel should be prepared to give the following information:

Information to Give to Emergency Personnel	
Site Location: Refer to Figure 3.2 below for directions and map to the site.	<p>Port of Tacoma Pier 4 Port of Tacoma Road and East 11th Street Tacoma, WA</p> <p>Site: Pier 4 is part of Husky Terminal, which is an active terminal for cargo ships, and is accessed by a driveway immediately before East 11th Street, on the northeast (right) side of Port of Tacoma Road. Transportation Worker Identification Credential (TWIC) cards are not required for emergency responders. Floyd Snider will inform the guards of their working area for the day so that they can direct emergency responders to field personnel in case of an emergency.</p>
Number that You are Calling from:	This information can be found on the phone you are calling from.
Type of Accident or Type(s) of Injuries:	Describe accident and/or incident and numbers of personnel needing assistance.

**Figure 3.2
Pier 4 Site**



3.4 FLOYD|SNIDER AND PORT EMERGENCY CONTACTS

After contacting emergency response crews as necessary, contact the Floyd|Snider PM or a Principal to report the emergency. The Floyd|Snider Contact may then contact the Port, or direct the field staff to do so.

Floyd|Snider Emergency Contacts:

Contact	Office Phone Number	Cell Phone Number
Jessi Massingale, Project Manager	(206) 292-2078	(206) 683-4307
Kate Snider, Principal		(206) 375-0762
Teri Floyd, Principal		(206) 713-1329
Erin Murray, HSO/SS		(206) 715-1422

Port Emergency Contacts:

Contact	Office Phone Number	Cell Phone Number
Mark Rettmann	(253) 592-6716	(253) 905-1449
Scott Hooton	(253) 383-9428	(253) 335-0689

4.0 Primary Responsibilities and Requirements

4.1 PROJECT MANAGER

The PM will have overall responsibility for the completion of the project, including the implementation and review of this HASP. The PM will review health and safety issues as needed and as consulted, and will have authority to allocate resources and personnel to safely accomplish the field work.

The PM will direct all Floyd|Snider personnel involved in field work at the site. If the project scope changes, the PM will notify the HSO/SS so that the appropriate addendum will be included in the HASP. The PM will ensure that all Floyd|Snider personnel on-site have received the required training, are familiar with the HASP, and understand the procedures to follow should an accident and/or incident occur on-site.

4.2 HEALTH AND SAFETY OFFICER AND SITE SUPERVISOR

The HSO/SS will approve this HASP and any amendments thereof, and will ultimately be responsible for full implementation of all elements of the HASP.

The HSO/SS will advise the PM and project personnel on all potential health and safety issues of the field investigation activities to be conducted at the site. The HSO/SS will specify required exposure monitoring to assess site health and safety conditions, modify the site HASP based on field assessment of health and safety accidents and/or incidents, and recommend corrective action if needed. The HSO/SS will report all accidents and/or incidents to the PM. If the HSO/SS observes unsafe working conditions by Floyd|Snider personnel or any contractor personnel, the HSO/SS will suspend all work until the hazard has been addressed. Under CERCLA, the federal On-Scene Coordinator also has the authority to stop work if he/she believes the work is being conducted in an unsafe manner.

4.3 SITE SAFETY OFFICER

The SSO may be a person dedicated to this task, to assist the HSO/SS during field work activities. The SSO will ensure that all personnel have appropriate personal protective equipment (PPE) on-site and PPE is properly used. The SSO will assist the HSO/SS in field observation of Floyd|Snider personnel safety. If a health or safety hazard is observed, the SSO shall suspend all work activity. The SSO will conduct on-site safety meetings daily before work commences. All health and safety equipment will be calibrated daily and records kept in the daily field logbook. The SSO may perform exposure monitoring if needed and will ensure that equipment is properly maintained. The SSO should complete a Daily Tailgate Safety Meeting and Debrief Form (Attachment 1) at the conclusion of daily sampling or at the conclusion of the sampling event.

4.4 FLOYD|SNIDER PROJECT PERSONNEL

All Floyd|Snider project personnel involved in field work activities will take precautions to prevent accidents and/or incidents from occurring to themselves and others in the work areas. Employees will report all accidents and/or incidents or other unsafe working conditions to the HSO/SS or SSO immediately. Employees will inform the HSO/SS or SSO of any physical conditions that could impact their ability to perform field work.

4.5 TRAINING REQUIREMENTS

All Floyd|Snider project personnel must comply with applicable regulations specified in the Washington Administrative Code (WAC) Chapter 296-843, Hazardous Waste Operations (HAZWOP), administered by the Washington State Department of Labor and Industries. Project personnel will be 40-hour HAZWOP trained and maintain their training with an annual 8-hour refresher. Personnel with limited tasks and minimal exposure potential will be required to have 24-hour training and a site hazard briefing and be escorted by a trained employee. Personnel with defined tasks that do not include potential contact with disturbed site soils or waste, groundwater, or exposures to visible dust (e.g., surveying) are not required to have any level of hazardous waste training beyond a site emergency briefing and hazard orientation by HSO/SS. Floyd|Snider project personnel will fulfill the medical surveillance program requirements.

At least one person on-site during field work will have current cardiopulmonary resuscitation (CPR)/First Aid certification. All field personnel will have a minimum of 3 days of hazardous materials field experience under the direction of a skilled supervisor.

The Husky Terminal is an active Port terminal that receives international cargo and is therefore accessible only to personnel with pre-approved security clearance by the Transportation Security Administration (TSA). In order to comply with this policy, all field personnel will have current TWIC cards issued by TSA and will be required to present them to site security in order to gain entry to the terminal.

Additional site-specific training that covers on-site hazards, PPE requirements, use and limitations, decontamination procedures, and emergency response information as outlined in this HASP will be given by the HSO/SS before on-site work activities begin.

5.0 Hazard Evaluation and Risk Analysis

In general, there are three broad hazard categories that may be encountered during site work: chemical exposure hazards, fire/explosion hazards, and physical hazards. Sections 5.1 through 5.3 discuss the specific hazards that fall within each of these broad categories.

5.1 CHEMICAL EXPOSURE HAZARDS

This section describes potential chemical hazards associated with sediment and soil sampling. The only chemical of concern encountered during the 2013 sampling effort that exceeded its DMMP screening level framework was TBT. Human health hazards of TBT are presented below:

- OSHA Permissible Exposure Limits: None established
- Maximum chemical concentration of TBT at/near the site: 50,000 micrograms per kilogram ($\mu\text{g}/\text{kg}$; bulk) in November 2013
- Routes of Exposure: Inhalation, skin absorption, ingestion, skin/eye contact
- Potential Toxic Effects: Eye irritation, skin irritation, difficulty breathing; gastrointestinal distress, possible endocrine disruptor

This information covers potential toxic effects that might occur if relatively significant acute and/or chronic exposure were to happen. This information does not mean that such effects will occur from the planned site activities. Potential routes of exposure include inhalation, dermal contact, ingestion, and eye contact. The primary exposure route of concern during site work is ingestion of contaminated soil or sediment, though such exposure is considered unlikely and highly preventable. In general, TBT that may be encountered at this site are not expected to be present in a form that could produce significant exposures. The types of planned work activities and use of monitoring procedures and protective measures will limit potential exposures at this site. The use of appropriate PPE and decontamination practices will assist in controlling exposure through all pathways to the contaminants listed in the table below.

5.2 FIRE AND EXPLOSION HAZARDS

Flammable and combustible liquid hazards may occur from fuels and lubricants brought to the property for drilling equipment. When on-site storage is necessary, such material will be stored in containers approved by the Washington State Department of Transportation in a location not exposed to strike hazards and provided with secondary containment. A minimum 2-A:20-B fire extinguisher will be located within 25 feet of the storage location and where refueling occurs. Any subcontractors bringing flammable and combustible liquid hazards to the site, are responsible for providing appropriate material for containment and spill response, and should be addressed in their respective HASP. Transferring of flammable liquids (e.g., gasoline) will occur only after making positive metal to metal connection between the containers, which may be achieved by using a bonding strap. Storage of ignition and combustible materials will be kept away from fueling operations.

5.3 PHYSICAL HAZARDS

When working in or around any hazardous or potentially hazardous substances or situations, all site personnel should plan all activities before starting any task. Site personnel shall identify health and safety hazards involved with the work planned and consult with the HSO/SS as to how the task can be performed in the safest manner, and if personnel have any reasons for concern or uncertainty.

All field personnel will adhere to general safety rules including wearing appropriate PPE—hard hats, steel-toed boots, high-visibility vests, safety glasses, gloves, and hearing protection, as appropriate. Eating, drinking, and/or use of tobacco or cosmetics will be restricted in all work areas. Personnel will prevent splashing of liquids containing chemicals and minimize dust emissions.

The following table summarizes a variety of physical hazards that may be encountered on the site during work activities. For convenience, these hazards have been categorized into several general groupings with recommended preventative measures.

Hazard	Cause	Prevention
Head strike	Falling and/or sharp objects, bumping hazards.	Hard hats will be worn by all personnel at all times when overhead hazards exist, such as during drilling activities.
Foot/ankle twist, crush, slip/trip/fall	Sharp objects, dropped objects, uneven and/or slippery surfaces.	Steel-toed boots must be worn at all times on-site while heavy equipment is present. Pay attention to footing on uneven or wet terrain and do not run. Keep work areas organized and free from unmarked trip hazards.
Hand cuts, splinters and chemical contact	Hands or fingers pinched or crushed, chemical hazards. Cut or splinters from handling sharp/rough objects and tools.	Nitrile safety gloves will be worn to protect the hands from dust and chemicals. Leather or cotton outer gloves will be used when handling sharp-edged rough materials or equipment. Refer to preventive measures for mechanical hazards below.
Eye damage from flying materials, or splash hazards	Sharp objects, poor lighting, exposure due to flying debris or splashes.	Safety glasses will be worn at all times on-site. If a pressure washer is used to decontaminate heavy equipment, a face shield will be worn over safety glasses or goggles. Care will be taken during decontamination procedures and groundwater sampling to avoid splashing or dropping equipment into decontamination water.

Hazard	Cause	Prevention
Electrical hazards	Underground utilities, overhead utilities. Electrical cord hazards, such as well development pumps.	Utility locator service will be used prior to any investigation to locate all underground utilities. Visual inspection of work areas will be conducted prior to starting work. Whenever possible, avoid working under overhead high voltage lines. Make sure that no damage to extension cords occurs. If an extension cord is used, make sure it is the proper size for the load that is being served and rated SJOW or STOW (an “-A” extension is acceptable for either) and inspected prior to use for defects. The plug connection on each end should be of good integrity. Insulation must be intact and extend to the plugs at either end of the cord. All portable power tools will be inspected for defects before use and must either be a double-insulated design or grounded with a ground-fault circuit interrupter.
Mechanical hazards	Heavy equipment such as sediment grab collection apparatus.	Ensure the use of competent operators, backup alarms, regular maintenance, daily mechanical checks, and proper guards. Subcontractors will supply their own HASP or supplemental equipment-specific safety protocols. All project personnel will make eye contact with operator and obtain a clear “okay” before approaching or working within swing radius of heavy equipment, staying clear of swing radius.
Traffic hazards	Vehicle traffic and hazards when working near active Port operations.	When working near high traffic areas orange cones and/or flagging will be placed around the work area. Safety vests will be worn at all times while conducting work off-site. Multiple field staff will work together (buddy system) and spot traffic for each other. Avoid working with your back to traffic whenever possible. Further detail on traffic hazards is provided in Section 5.3.4.

Hazard	Cause	Prevention
Water hazards	Carelessness during in-water work, entry into unsafe areas of sampling vessel.	When collecting samples from a vessel, wear a personal flotation device (PFD) at all times in addition to the standard level D PPE and move carefully to avoid slips and falls. Do not enter prohibited areas of the vessel. In addition, those working from the pier deck should be mindful of their proximity to the edge of the pier to prevent falling and drowning hazards.
Noise damage to hearing	Machinery creating more than 85 decibels TWA, less than 115 decibels continuous noise, or peak at less than 140 decibels.	Wear earplugs or protective ear covers when a conversational level of speech is difficult to hear at a distance of 3 feet; when in doubt, a sound level meter may be used on-site to document noise exposure.
Strains from improper lifting	Injury due to improper lifting techniques, over-reaching/ overextending, lifting overly heavy objects.	Use proper lifting techniques and mechanical devices where appropriate. The proper lifting procedure first involves testing the weight of the load by tipping it. If in doubt, ask for help. Do not attempt to lift a heavy load alone. Take a good stance and plant your feet firmly with legs apart, one foot farther back than the other. Make sure you stand on a level area with no slick spots or loose gravel. Use as much of your hands as possible, not just your fingers. Keep your back straight, almost vertical. Bend at the hips, holding load close to your body. Keep the weight of your body over your feet for good balance. Use large leg muscles to lift. Push up with one foot positioned in the rear as you start to lift. Avoid quick, jerky movements and twisting motions. Turn the forward foot and point it in the direction of the eventual movement. Never try to lift more than you are accustomed to lifting.
Cold stress	Cold temperatures and related exposure.	Workers will ensure appropriate clothing, stay dry, and take breaks in a heated environment when working in cold temperatures. Further detail on cold stress is provided in Section 5.3.1.
Heat exposure	High temperatures exacerbated by PPE, dehydration.	Workers will ensure adequate hydration, shade, and breaks when temperatures are elevated. Further detail on heat stress is provided in Section 5.3.2.

Hazard	Cause	Prevention
Accidents due to inadequate lighting	Improper illumination.	Work will proceed during daylight hours only, or under sufficient artificial light.

5.3.1 Cold Stress

Field work is expected to be completed in summer; however, if additional phases of work are required, or activities are conducted in winter months, or a fall into water occurs, exposure to cold temperatures may be possible. Exposure to moderate levels of cold can cause the body's internal temperature to drop to a dangerously low level, causing hypothermia. Symptoms of hypothermia include slow, slurred speech, mental confusion, forgetfulness, memory lapses, lack of coordination, and drowsiness.

To prevent hypothermia, site personnel will stay dry and avoid exposure. Site personnel will have access to a warm, dry area, such as a vehicle, to take breaks from the cold weather and warm up. Site personnel will be encouraged to wear sufficient clothing in layers such that outer clothing is wind- and waterproof and inner layers retain warmth (wool or polypropylene), if applicable. Site personnel will keep hands and feet well protected at all times. The signs and symptoms and treatment for hypothermia are summarized below.

Signs and Symptoms

- Mild hypothermia (body temperature of 98–90° F)
 - Shivering
 - Lack of coordination, stumbling, fumbling hands
 - Slurred speech
 - Memory loss
 - Pale, cold skin
- Moderate hypothermia (body temperature of 90–86° F)
 - Shivering stops
 - Unable to walk or stand
 - Confused and irrational
- Severe hypothermia (body temperature of 86–78° F)
 - Severe muscle stiffness
 - Very sleepy or unconscious
 - Ice cold skin
 - Death

Treatment of Hypothermia—Proper Treatment Depends on the Severity of the Hypothermia

- Mild hypothermia
 - Move to warm area.
 - Stay active.
 - Remove wet clothes and replace with dry clothes or blankets and cover the head.
 - Drink warm (not hot) sugary drinks.
- Moderate hypothermia
 - All of the above, plus:
 - call 911 for an ambulance,
 - cover all extremities completely,
 - place very warm objects such as hot packs or water bottles on the victim's head, neck, chest and groin.
- Severe hypothermia
 - Call 911 for an ambulance.
 - Treat the victim very gently.
 - Do not attempt to re-warm—the victim should receive treatment in a hospital.

Frostbite

Frostbite occurs when the skin actually freezes and loses water. In severe cases, amputation of the frostbitten area may be required. While frostbite usually occurs when the temperatures are 30° F or lower, wind chill factors can allow frostbite to occur in above-freezing temperatures. Frostbite typically affects the extremities, particularly the feet and hands. Frostbite symptoms include cold, tingling, stinging, or aching feeling in the frostbitten area followed by numbness and skin discoloration from red to purple, then white or very pale skin. Should any of these symptoms be observed, wrap the area in soft cloth, do not rub the affected area, and seek medical assistance. Call 911 if the condition is severe.

Protective Clothing

Wearing the right clothing is the most important way to avoid cold stress. The type of fabric also makes a difference. Cotton loses its insulation value when it becomes wet. Wool, on the other hand, retains its insulation even when wet. The following are recommendations for working in cold environments:

- *Wear at least three layers* of clothing.
 - An outer layer to break the wind and allow some ventilation (like Gortex or nylon).
 - A middle layer of down or wool to absorb sweat and provide insulation even when wet.
 - An inner layer of cotton or synthetic weave to allow ventilation.

- Wear a hat—up to 40 percent of body heat can be lost when the head is left exposed.
- Wear insulated boots or other footwear.
- Keep a change of dry clothing available in case work clothes become wet.
- Do not wear tight clothing—loose clothing allows better ventilation.

Work Practices

- Drinking—Drink plenty of liquids, avoiding caffeine and alcohol. It is easy to become dehydrated in cold weather.
- Work Schedule—If possible, heavy work should be scheduled during the warmer parts of the day. Take breaks out of the cold in heated vehicles.
- Buddy System—Try to work in pairs to keep an eye on each other and watch for signs of cold stress.

5.3.2 Heat Stress

To avoid heat-related illness, current regulations in WAC 296-62-095 through 296-62-09570 will be followed during all outdoor work activities. These regulations apply to any outdoor work environment from May 1 through September 30, annually when workers are exposed to temperatures greater than 89° F when wearing breathable clothing, greater than 77° F when wearing double-layered woven clothing (such as jackets or coveralls) or greater than 52° F when wearing non-breathing clothing such as chemical resistant suits or Tyvek. Floyd|Snider will identify and evaluate temperature, humidity, and other environmental factors associated with heat-related illness including, but not limited to, the provision of rest breaks that are adjusted for environmental factors, and encourage frequent consumption of drinking water. Drinking water will be provided and made readily accessible in sufficient quantity to provide at least 1 quart per employee per hour. All Floyd|Snider personnel will be informed and trained for responding to signs or symptoms of possible heat-related illness and accessing medical aid.

Employees showing signs or demonstrating symptoms of heat-related illness must be relieved from duty and provided with a sufficient means to reduce body temperature, including rest areas or temperature-controlled environments (i.e., air conditioned vehicle). Any employee showing signs or demonstrating symptoms of heat-related illness must be carefully evaluated to determine whether it is appropriate to return to work or if medical attention is necessary.

Any incidence of heat-related illness must be immediately reported to the employer directly through the HSO/SS.

The signs, symptoms, and treatment of heat stress include the following:

Condition	Signs/Symptoms	Treatment
Heat cramps	Painful muscle spasms and heavy sweating.	Increase water intake, rest in shade/cool environment.
Heat syncope	Brief fainting and blurred vision.	Increase water intake, rest in shade/cool environment.
Dehydration	Fatigue, reduced movement, headaches.	Increase water intake, rest in shade/cool environment.
Heat exhaustion	Pale and clammy skin, possible fainting, weakness, fatigue, nausea, dizziness, heavy sweating, blurred vision, body temperature slightly elevated.	Lie down in cool environment, water intake, loosen clothing, and call 911 for ambulance transport if symptoms continue once in cool environment.
Heat stroke	Cessation of sweating, skin hot and dry, red face, high body temp, unconsciousness, collapse, convulsions, confusion or erratic behavior, life threatening condition.	Medical Emergency!! Call 911 for ambulance transport. Move victim to shade and immerse in water.

If site temperatures are forecast to exceed 85° F and physically demanding site work will occur in impermeable clothing, the HSO/SS will promptly consult with a certified industrial hygienist and a radial pulse monitoring method will be implemented to ensure that heat stress is properly managed among the affected workers. The following heat index chart indicates the relative risk of heat stress.

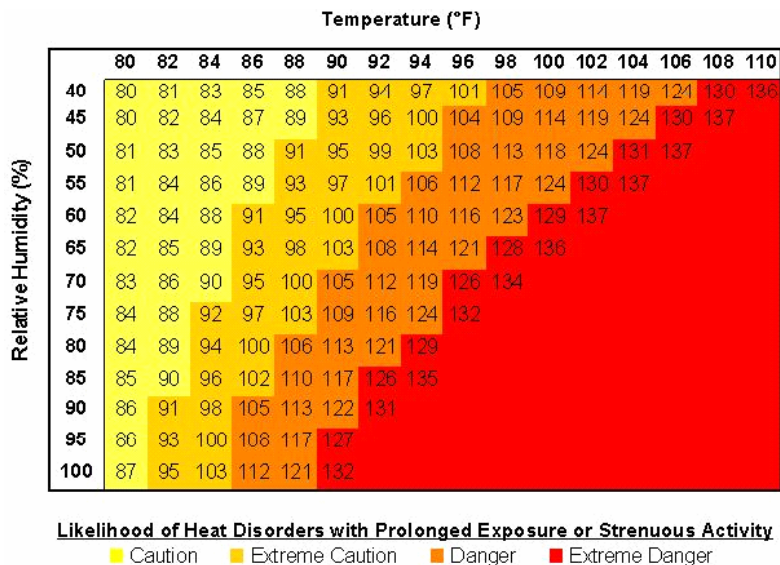

5.3.3 Biohazards

Bees and other insects may be encountered during the field work tasks. Persons with allergies to bees will make the HSO/SS aware of their allergies and will avoid areas where bees are identified. Those with anaphylactic reactions to allergens should have their medication in good condition and with at the site. Controls such as repellents, hoods, nettings, masks, or other personal protection may be used. Report any insect bites or stings to the HSO/SS and seek first aid, if necessary.

Site personnel will maintain a safe distance from any urban wildlife encountered, including stray dogs, raccoons, and rodents, to preclude a bite from a sick or injured animal. Personnel will be gloved and will use tools to lift covers from catch basins and monitoring wells.

5.3.4 Traffic Hazards

A portion of work is being conducted at an active Port facility, nearby or alongside areas with heavy truck traffic. Care must be taken to work in a designated sample processing area, and to use barricades such as cones and the field vehicle to protect personnel when it is necessary to work in areas with active operations. Because these barricades do not always provide appropriate protection, spotters may be used to ensure traffic is monitored during work activities. All workers will wear high visibility reflective neon/orange vests.

6.0 Site Monitoring

The following sections describe site monitoring techniques and equipment that are to be used during site field activities. The HSO/SS, or a designated alternate, is responsible for site control and monitoring activities.

6.1 SITE MONITORING

Air monitoring will not be conducted, as there are no known or anticipated volatile compounds in site soils or sediments. Visual monitoring for dust will be conducted by the HSO/SS to ensure that inhalation of contaminated soil particles does not occur; however the field activities are not expected to generate substantial dust. If visible dust is present in the work area, work will cease, and the area will be cleared until the dust settles. Water may be used to suppress any dust clouds generated during work activities. The HSO/SS will visually inspect the work site at least daily to identify any new potential hazards. If new potential hazards are identified, immediate measures will be taken to eliminate or reduce the risks associated with these hazards.

7.0 Hazard Analysis by Task

The following section identifies potential hazards associated with each task listed in Section 2.2 of this HASP. Tasks have been grouped according to the types of potential hazard associated with them.

Task	Potential Hazard
Collection of Sediment Grabs	Exposure to loud noise; overhead hazards; head, foot, ankle, hand, and eye hazards; electrical and mechanical hazards; lifting hazards; dust inhalation hazards; potential dermal or eye exposure to site contaminants in groundwater and soil; fall hazards; traffic hazards; and heat and cold exposure hazards. In-water work also presents drowning hazards and increased risk of cold exposure and hypothermia.
Sediment Sampling and Compositing	Chemical hazards include potential dermal or eye exposure to site contaminants in soil and sediments. Physical hazards include slip, trip, or fall hazards; heat and cold exposure hazards; and biological hazards.

8.0 Personal Protective Equipment

All work will proceed in Level D PPE, which shall include hard hat, steel-toed boots, hearing protection, eye protection, gloves, and sturdy outer work clothing.

All personnel will be properly fitted and trained in the use of PPE. The level of protection will be upgraded by the HSO/SS whenever warranted by conditions present in the work area. The HSO/SS will periodically inspect equipment such as gloves and hard hats for defects.

For all work involving potential exposure to soil or groundwater, workers will wear nitrile gloves and Level D PPE.

PFDs will be worn at all times during in-water work.

High visibility vests will be worn when working around heavy equipment, and off-site on road shoulders.

9.0 Site Control and Communication

9.1 SITE CONTROL

Pier 4 is owned by the Port and occupied by Husky Terminal and access to the site will be restricted to designated personnel at all times. The purpose of site control is to minimize other workers' potential exposure to site hazards and access by unauthorized persons, and to provide adequate facilities for workers.

9.2 COMMUNICATION

All site work will occur in teams and the primary means of communication on-site and with off-site contacts will be via cell phones. An agreed-upon system of alerting via air horns and/or vehicle horns may be used around heavy equipment to signal an emergency if shouting is ineffective.

10.0 Decontamination and Waste Disposal

10.1 DECONTAMINATION

Decontamination procedures will be strictly followed to prevent off-site spread of contaminated soil or water. The HSO/SS will assess the effectiveness of decontamination procedures by visual inspection.

Hands must be thoroughly washed before leaving the site to eat, drink, or use tobacco.

10.2 WASTE DISPOSAL

Floyd|Snider and its subcontractors will employ safe and prudent waste collection and housekeeping practices to minimize the spread of contamination beyond the work zone and the amount of investigation-derived wastes. Excess sediment from grab sample collection will be collected in buckets aboard the sampling vessel and either taken to the transload site via a skiff or containerized at an uplands location within the project area. Any incidental waste materials (i.e., gloves, paper towels, etc.) will be placed immediately into trash bags and disposed as municipal waste.

11.0 Emergency Response and Contingency Plan

This section defines the emergency action plan for the site. It will be rehearsed with all site personnel and reviewed whenever the plan is modified or the HSO/SS believes that site personnel are unclear about the appropriate emergency actions.

A muster point of refuge (that is clear of adjacent hazards and not located downwind of site investigation activities) will be identified by the HSO/SS and communicated to the field team each day. In an emergency, all site personnel and visitors will evacuate to the muster point for roll call. It is important that each person on-site understand their role in an emergency, and that they remain calm and act efficiently to ensure everyone's safety.

After each emergency is resolved, the entire project team will meet and debrief on the incident—the purpose is not to fix blame, but to improve the planning and response to future emergencies. The debriefing will review the sequence of events, what was done well, and what can be improved. The debriefing will be documented in a written format and communicated to the PM. Modifications to the emergency plan will be approved by the PM.

Reasonably foreseeable emergency situations include medical emergencies, accidental release of hazardous materials (such as gasoline or diesel) or hazardous waste, and general emergencies such as vehicle accident, fire, thunderstorm, and earthquake. Expected actions for each potential incident are outlined below.

11.1 MEDICAL EMERGENCIES

In the event of a medical emergency, the following procedures should be used:

- Stop any imminent hazard if you can safely do so.
- Remove ill, injured, or exposed person(s) from immediate danger if moving them will clearly not cause them harm and no hazards exist to the rescuers.
- Evacuate other on-site personnel to a safe place in an upwind or cross-wind direction until it is safe for work to resume.
- If serious injury or a life-threatening condition exists, call **911** for paramedics, fire department, and police. Additionally, contact the Port so that they can initiate their emergency response procedure.

Clearly describe the location, injury, and conditions to the dispatcher. Designate a person to go to the site entrance and direct emergency equipment to the injured person(s). Provide the responders with a copy of this HASP to alert them to chemicals of potential concern.

- Trained personnel may provide first aid/cardiopulmonary resuscitation if it is necessary and safe to do so. Remove contaminated clothing and PPE only if this can be done without endangering the injured person.

- Call the PM and HSO/SS.
- Immediately implement steps to prevent recurrence of the accident.

Refer to Figure 1 in Section 3.2 for a map showing the nearest hospital location with phone number and address.

11.2 ACCIDENTAL RELEASE OF HAZARDOUS MATERIALS OR WASTES

1. Evacuate all on-site personnel to a safe place in an upwind direction until the HSO/SS determines that it is safe for work to resume.
2. Instruct a designated person to contact the PM and confirm a response.
3. Contain the spill, if it is possible and can be done safely.
4. If the release is not stopped, contact 911 to alert the fire department. Also contact the Port so that they know to expect emergency responders.
5. Contact the National Response Center at 1-800-424-8802 and the Washington State Emergency Response Commission at 1-800-258-5990 to report the release.
6. Initiate cleanup.
7. The PM will submit a written report to the Washington State Department of Ecology in the event of a reportable release of hazardous materials or wastes.

11.3 GENERAL EMERGENCIES

In the case of fire, explosion, earthquake, or imminent hazards, work shall be halted and all on-site personnel will be immediately evacuated to a safe place. The local police/fire department shall be notified if the emergency poses a continuing hazard by calling 911.

In the event of a thunderstorm, outdoor work will be discontinued until the threat of lightning has abated. During the incipient phase of a fire, the available fire extinguisher(s) may be used by persons trained in putting out fires, if it is safe for them to do so. Contact the fire department as soon as feasible.

11.4 EMERGENCY COMMUNICATIONS

In the case of an emergency, an air horn or car horn will be used as needed to signal the emergency. One long (5-second) blast will be given as the emergency/stop work signal. If the air horn is not working, a vehicle horn and/or overhead waving of arms will be used to signal the emergency. In any emergency, all personnel will evacuate to the designated refuge area and await further instruction.

11.5 EMERGENCY EQUIPMENT

The following minimum emergency equipment will be readily available on-site and functional at all times:

- First Aid Kit—contents approved by the HSO/SS, including two blood borne pathogen barriers.
- Sorbent materials capable of absorbing the volume of liquids/fuels brought to the site by Floyd|Snider personnel.
- Portable fire extinguisher (2-A:10 B/C min).
- A copy of the current HASP.

12.0 Administrative

12.1 MEDICAL SURVEILLANCE

Floyd|Snider personnel involved with field activities must be covered under Floyd|Snider's medical surveillance program that includes biennial physical examinations. These medical monitoring programs must be in compliance with all applicable worker health and safety regulations.

12.2 RECORDKEEPING

The HSO/SS, or a designated alternate, will be responsible for keeping attendance lists of personnel present at site health and safety meetings, accident reports, and signatures of all personnel who have read this HASP.

13.0 Approvals

Project Manager

Date

Project Health & Safety Officer

Date

Attachment 1
Daily Tailgate Safety Meeting and Debrief Form

DAILY TAILGATE SAFETY MEETING AND DEBRIEF FORM

Instructions

To be completed by supervisor prior to beginning of work each day, when changes in work procedures occur, or when additional hazards are present. Please maintain a copy of this form with the site-specific HASP for the record.

PROJECT NAME AND ADDRESS:

WORK COMPLETED/TOOLS USED:

--	--

TOPICS/HAZARDS DISCUSSED:

Chemicals of concern:
Slip, trip, fall:
Heat or cold stress:
Required PPE:
Other Potential Hazards:
• Environmental:
• Physical:
• Biological:
• Other :

INFORMAL TRAINING CONDUCTED (Name, topics):

NAMES OF EMPLOYEES:

ADDITIONAL HAZARDS IDENTIFIED AT END OF WORK DAY:

Near Misses/Incidents? If so proceed to Page 2 Near Miss and Incident Reporting Form

Supervisors Signature/Date: _____

NEAR MISS AND INCIDENT REPORTING FORM

INCIDENTS:

INJURIES:

NEAR MISSES:

CORRECTIVE ACTIONS:

Supervisors Signature/Date:

**Pier 4 Phase 1 Removal
Action Project**

Removal Action Work Plan

**Appendix B
Water Quality Monitoring and
Protection Plan**

Table of Contents

1.0 Introduction B-1

1.1 PROJECT DESCRIPTION..... B-1

2.0 Construction Methods and Water Quality Protection Measures B-3

2.1 GENERAL WATER QUALITY PROTECTION MEASURES B-3

2.2 OVER-WATER DEMOLITION OF THE MAJORITY OF THE PIER 4 STRUCTURE B-4

2.2.1 Best Management Practices B-4

2.3 NAVIGATION LIGHT PILE REMOVAL AND INSTALLATION B-5

2.3.1 Best Management Practices B-6

2.4 VIBRATORY PILE EXTRACTION..... B-6

2.4.1 Best Management Practices B-6

2.5 DREDGING B-7

2.5.1 Best Management Practices B-8

2.6 TRANSLOADING B-10

2.6.1 Best Management Practices B-12

2.7 DEWATERING TREATMENT SYSTEM AND DREDGE RETURN WATER B-15

2.8 POTENTIAL POST-DREDGE SAND PLACEMENT B-15

2.8.1 Best Management Practices B-16

2.9 CONCRETE TEST PILE PROGRAM..... B-16

2.9.1 Best Management Practices B-16

3.0 Water Quality Monitoring Objectives and Standards B-19

3.1 WATER QUALITY STANDARDS..... B-19

3.1.1 Turbidity B-19

3.1.2 Narrative Water Quality Standards B-20

3.1.3 Water Quality Criteria for Tributyltin B-20

3.1.4 Performance Standard for pH..... B-21

4.0 Types of Monitoring..... B-23

4.1 VISUAL MONITORING B-23

4.1.1 Visual Monitoring Parameters B-23

4.2 INSTRUMENTED MONITORING..... B-23

4.3	CHEMICAL TRIBUTYLTIN MONITORING	B-24
5.0	Monitoring Plan during all In-water Activities	B-25
5.1	MONITORING STATIONS.....	B-25
5.2	MONITORING DEPTHS	B-26
5.3	TIER 1—INTENSIVE WATER QUALITY SCHEDULE DURING TBT- CONTAMINATED DREDGING.....	B-26
5.3.1	Turbidity Compliance.....	B-27
5.3.2	Tributyltin Compliance.....	B-28
5.4	TIER 2—ROUTINE WATER QUALITY SCHEDULE FOR ALL IN-WATER ACTIVITIES	B-28
5.4.1	Turbidity Compliance.....	B-28
5.5	RESPONSES TO ELEVATIONS AT THE EARLY WARNING POINT OR EXCEEDENCES OF COMPLIANCE CRITERIA DURING TIER 1 INTENSIVE MONITORING.....	B-29
5.5.1	Turbidity at the Compliance Stations	B-29
5.5.2	Tributyltin at the Compliance Stations	B-30
6.0	Monitoring Plan during Dredge Return Water Monitoring	B-35
6.1	MONITORING STATIONS.....	B-35
6.2	MONITORING DEPTHS	B-35
6.3	TIER 1—INTENSIVE WATER QUALITY SCHEDULE.....	B-36
6.3.1	Turbidity Compliance.....	B-36
6.3.2	Tributyltin Compliance.....	B-37
6.4	TIER 2—ROUTINE WATER QUALITY SCHEDULE	B-37
6.5	RESPONSES TO EXCEEDANCES OF COMPLIANCE CRITERIA DURING TIER 1 INTENSIVE MONITORING	B-38
6.5.1	Turbidity at the Acute Compliance Station.....	B-38
6.5.2	Tributyltin Results for Acute Water Quality Samples from End- of-Pipe Effluent	B-39
7.0	Water Quality Compliance Monitoring Methods.....	B-43
7.1	MONITORING EQUIPMENT.....	B-43
7.2	POSITIONING METHODOLOGY	B-43
7.3	WATER QUALITY MONITORING AND SAMPLING METHODOLOGY AT LOCATIONS WITHIN THE WATERWAY	B-43

7.4	MONITORING AND SAMPLING METHODOLOGY FROM THE DREDGE RETURN WATER TREATMENT SYSTEM	B-44
7.5	DECONTAMINATION PROCEDURES	B-44
7.6	FIELD QUALITY ASSURANCE SAMPLES	B-44
7.7	DOCUMENTATION AND USEPA REPORTING	B-45
7.8	LABORATORY TRIBUTYLTIN ANALYSIS AND QUALITY CONTROL	B-45
7.8.1	Laboratory Analysis Protocols.....	B-45
7.8.2	Limits of Detection.....	B-45
7.8.3	Quality Assurance/Quality Control	B-46
8.0	Corrective Actions and Notification Plan	B-47
8.1	CORRECTIVE ACTIONS DURING IN-WATER WORK.....	B-47
8.2	CORRECTIVE ACTIONS DURING DREDGE RETURN WATER MONITORING.....	B-47
8.3	CESSATION OF ACTIVITIES.....	B-48
8.3	NOTIFICATION.....	B-49
9.0	References	B-51

List of Tables

Table B.1	Tributyltin Analytical Method and Target Quantitation Limit
Table B.2	Water Quality Monitoring Schedule and Requirements for all In-Water Activities
Table B.3	Water Quality Monitoring Schedule and Requirements for Dredge Return Water Monitoring
Table B.4	Analytical Requirements, Methods, Preservation, Bottle Type, and Holding Times
Table B.5	Data Quality Assurance Criteria

List of Figures

Figure B.1	Vicinity Map
Figure B.2	Site Location Map of Pier 4
Figure B.3	Figure B.3 Monitored Construction Activities of Majority of Pier 4 Structure Removal, Pile Installation, and Pile Extraction
Figure B.4	Monitored Construction Activity of Clean Riprap Removal, Dredging, and Potential Post-Dredge Sand Placement

- Figure B.5 Tier 1 Intensive Water Quality Schedule during TBT-Contaminated Sediment Dredging
- Figure B.6 Tier 2 Routine Water Quality Schedule during Pile Extraction, Navigation Light Pile Installation, and Dredging
- Figure B.7 Tier 1 Intensive Water Quality Schedule during Dredge Return Water Monitoring
- Figure B.8 Tier 2 Routine Water Quality Schedule during Dredge Return Water Monitoring

List of Attachments

- Attachment B.1 Water Quality Monitoring Form

List of Acronyms and Abbreviations

Acronym/ Abbreviation	Definition
AOC	Agreed order on consent
BMP	Best management practice
CY	Cubic yards
DMMP	Dredged Material Management Program
DQOs	Data quality objectives
GAC	Granular Activated Carbon
NTU	Nephelometric Turbidity Unit
OHWM	Ordinary high water mark
Phase 1 Removal Action	Pier 4 Phase 1 Removal Action Project
The Port	Port of Tacoma
QA	Quality assurance
QC	Quality control
RAWP	Removal Action Work Plan
SWPPP	Stormwater Pollution Prevention Plan
TBT	Tributyltin
USEPA	U.S. Environmental Protection Agency
WAC	Washington Administrative Code
WDFW	Washington Department of Fish and Wildlife
WQMPP	Water Quality Monitoring and Protection Plan

1.0 Introduction

This Water Quality Monitoring and Protection Plan (WQMPP) has been prepared on behalf of the Port of Tacoma (the Port) and identifies monitoring and best management practices (BMPs) for construction activities associated with the Port's Pier 4 Phase 1 Removal Action Project (Phase 1 Removal Action). The project site is located on the west side of the northern portion of the Blair Waterway that lies within the Port's Industrial Development District, which is adjacent to Commencement Bay, in Tacoma, Washington (Figures B.1 and B.2).

The WQMPP, which is a required document by the U.S. Environmental Protection Agency (USEPA), has been prepared to ensure compliance with Section 401 of the Clean Water Act and Washington State Water Quality Standards, Chapter 173-201A of the Washington Administrative Code (WAC). This plan describes water quality protection measures; monitoring parameters, methods, and evaluation criteria; and contingency response and notification procedures in the event a water quality criterion is exceeded during construction activities. The project contractor (the Contractor) selected to perform the construction activities will be subject to the requirements and procedures specified in this plan, the USEPA-approved Removal Action Work Plan (RAWP), and the USEPA 401 Water Quality Memorandum, as well as the contract specifications.

1.1 PROJECT DESCRIPTION

The Port is proposing to clean up approximately 49,000 cubic yards (CY) of tributyltin-(TBT) contaminated sediments located under Pier 4, as part of an agreed order on consent (AOC) that was entered into with USEPA in June 2014. The AOC called for a site removal action evaluation, which included an additional soil, sediment, and ambient site water sampling event that was conducted in July 2014. Following the review of the preliminary results of the July sampling event, USEPA determined that the cleanup of the TBT-contaminated sediments is to proceed as a Time Critical Removal Action. As the cleanup of the TBT-contaminated sediments will occur under an AOC between the Port and USEPA, this phase of the project is exempt from securing individual agency permits, but will comply with the substantive requirements of such permits.

The work occurring at Pier 4 will have two distinct work phases: (1) the Phase 1 Removal Action, which includes a USEPA-ordered cleanup of contaminated sediment (and is the subject of this WQMPP), and (2) the Pier 4 Phase 2 Reconfiguration Project (Phase 2 Project), which includes reconfiguration of the existing pier. The Phase 1 Removal Action is described in more detail below. The proposed project, including both phases, is planned to be completed over 3 years, with work tentatively scheduled to be conducted between 2015 and early 2018.

The Phase 1 Removal Action includes the following tasks:

- Mobilization and staging of equipment and materials.
- Demolition of the majority of the existing Pier 4 structure, approximately 140,550 square feet (approximately 133,780 square feet waterward of the ordinary high water mark [OHWM], including the existing bulkhead).
- Vibratory removal of approximately 1,047 16.5-inch-diameter concrete piles.
- Vibratory removal of approximately 87 14-inch-diameter creosote-treated timber piles and 22 20-inch-diameter steel pipe piles associated with an existing pile-supported fender system.
- Removal and relocation of the existing navigation light on the south end of the pier as well as its companion navigation light that is pile-supported, located on the other side of the Blair Waterway, including the removal of four 18-inch-diameter existing steel piles located on the other side of the waterway, and the installation of a total of eight 18-inch-diameter steel piles for the replacement navigation lights. Removal and relocation of navigation lights will be done in coordination with the U.S. Coast Guard and the Puget Sound Pilots.
- Removal of approximately 2,300 CY of riprap that overlies clean top of slope sediments, to allow dredging and open-water disposal of 9,000 CY of clean sediments.
- Placement of clean riprap armoring (approximately 300 CY) for temporary slope stabilization in the vicinity of the electrical substation to prevent undermining of the structure.
- Dredging of approximately 49,000 CY of TBT-contaminated sediments, and approximately 9,000 CY of clean sediments.
- Transloading and upland disposal of dredged material. In order to protect the existing fender system along the APM Terminal pier, up to 10 steel piles may be installed along the pier face for barge berthing. If installed, they will be removed prior to project completion.
- Management and treatment of contaminated dredged material return water.
- Potential post-dredge sand placement in hot spots, if necessary.
- Concrete test pile placement and removal.
- Water quality monitoring, dredge elevation surveying, and confirmational sampling, both inside and outside of the dredge prism.

This WQMPP applies to work conducted below the project-specific OHWM, as well as some over-water construction activities that will require specific BMPs. In-water work is defined throughout this plan as work conducted waterward of and below the project-specific OHWM elevation of +12.78 feet mean lower low water (MLLW) as determined during a July 2014 field inspection (Confluence 2014).

2.0 Construction Methods and Water Quality Protection Measures

This section describes the protection measures that will be implemented during all in-water work, near-water work, and over-water work (as specified below) to minimize impacts on aquatic life and water quality. The construction activities and the type of water quality monitoring that will be performed (i.e., instrumented, visual, and/or chemical monitoring) are shown on Figures B.3 and B.4.

2.1 GENERAL WATER QUALITY PROTECTION MEASURES

The project elements have been designed to minimize adverse impacts on the environment due to the project activities, specifically, in-water work below the OHWM (i.e., pile removal and installation, dredging) and above- or near-water work (deck demolition and general over-water work).

The following general water quality protection measures will be implemented on a project-wide basis to reduce, eliminate, or minimize the effects of the removal action on water quality:

- No materials will be stockpiled below the OHWM in any water body.
- Fueling and servicing of all equipment, with the exception of barge derricks, will be confined to an established staging area. Barge derricks will be fueled and serviced while they float. Spill containment systems will be adequate to contain all fuel leaks.
- At least two oil-absorbing floating booms, appropriate for the size of the work area, will be available on-site whenever heavy equipment operates within 150 feet of open water and there is a potential for hazardous materials to enter surface waters. The booms will be stored in a location that facilitates their immediate deployment in the event of a spill.
- Barges will not ground out or rest on the substrate or be over or within 25 feet of vegetated shallows (except where such vegetation is limited to state-designated noxious weeds).
- The bottom of any structure, vessel, watercraft grid, or watercraft lift will be at least 1 foot above the level of the substrate during all water levels.
- Equipment and vehicles will be stored in established staging areas when not in use (excluding cranes, which cannot be moved easily).
- A written spill prevention, control, and countermeasures plan will be prepared for activities that include the use of heavy equipment. The plan will describe measures to prevent or reduce impacts due to accidental leaks or spills, as well as all hazardous materials that will be used, their proper storage and handling, and the methods that will be used to monitor their use.
- Upon advance notice, the Port will provide access to the construction site for representatives of USEPA, City of Tacoma, WDFW, USACE, U.S. Fish and

Wildlife Service (USFWS)/National Marine Fisheries Service (NMFS; hereafter referred to as “the Services”), the Puyallup Tribe of Indians, and Ecology, during all hours when the removal action is being conducted.

- No new access roads, routes, or trails will be constructed as part of the removal action.

2.2 OVER-WATER DEMOLITION OF THE MAJORITY OF THE PIER 4 STRUCTURE

Project activities will include demolishing the majority of the Pier 4 structure. This includes the existing Pier 4 deck between Bents 92 and 144 (approximately 1,040 feet). The existing fender system, utilities, and other appurtenances will be removed and will be followed by the demolition of the existing crane beam, bull rail, and all crane appurtenances. Demolition of the pier deck, deck beams, and pile caps will then take place, followed by pile extraction, as described below in Section 5.4. Approximately 140,550 square feet of existing decking will be removed, beginning with saw cutting and removing the existing pavement and ballast. The existing asphalt thickness varies from 3 to 6 inches over approximately 1 to 3 feet of ballast. Both the ballast and asphalt will be excavated, and removed using standard construction excavation equipment. After the pavement and ballast have been removed, the concrete elements of the deck will be removed in large pieces to be broken up upland from the pier. The bulkhead and supporting batter piles will also be demolished and removed, along with the pier structure, as the pier deck demolition progresses. A portion of underground utilities will also be demolished during this phase of work. The two existing storm drainage outfalls in the dredge area will be relocated to the new dredge cut line and stabilized, as necessary, to continue functioning. Demolition will proceed according to regulatory requirements using industry standard BMPs. Debris will be disposed of according to regulatory requirements, and materials will be recycled to the extent practicable. Demolition activities will occur over approximately 100 calendar days. All of the demolition activities, excluding pile extraction as described below, will be conducted above the project-specific OHWM or in the dry at any elevation, including upland demolition activities (utilities) and over-water demolition of the deck and fender system.

2.2.1 Best Management Practices

To minimize the potential for adverse water quality impacts during the demolition of the Pier 4 structure, the following BMPs will be implemented:

- All equipment that will operate over water or below OHWM will be free of accumulated grease, oil, or mud. All leaks will be repaired prior to arriving on-site. Equipment will be inspected daily for leaks, and accumulations of grease, oil, or mud. Any identified problems will be fixed before the equipment is operated over water or below OHWM.
- An emergency spill kit will be available on-site during construction whenever work is being performed in or near the water. It will be stored in a location that facilitates its immediate deployment if needed.

- BMPs will be used to ensure no work materials or debris enter the water. Such BMPs may include, but are not limited to, floats, falsework, scaffolding, and other means as necessary to prevent debris from falling into the water.
- As a contingency item, in the event that any materials or debris do enter the water despite BMP implementation, buoyant materials dropped into the water will be picked up immediately by the Contractor. The Contractor will have a boat available and on-site during in-water activities for floating debris retrieval. Materials that sink to the bottom are to be noted and picked up immediately; however, depending on the type of item and where it falls, materials may be removed at a later date in coordination with the Port and USEPA to avoid resuspension of contaminated materials. The means and method of item retrieval is subject to the approval of the Port and USEPA.
- A containment boom will be placed around the perimeter of the construction site during demolition and pile removal activities to contain floating debris and materials in the event that materials or debris do enter the water despite BMP implementation during project activities. The captured debris will be removed upon completion each day.

2.3 NAVIGATION LIGHT PILE REMOVAL AND INSTALLATION

The existing navigation light at the south end of Pier 4 will be relocated to accommodate demolition of the pier, and, based on communications with the Puget Sound Pilots and U.S. Coast Guard, it is also necessary to relocate its companion light (pile-supported), which is located on the other side of the Blair Waterway. The Contractor is required to install temporary navigation lights, as necessary, during the removal and relocation of the lights. The new lights in their new locations will be constructed on free standing, in-water platforms, each supported on four driven steel piles, for a total of eight piles. The piles will be installed using a hydraulic vibratory hammer. The Port is proposing conducting the removal of the existing navigation light at the south end of Pier 4 (located on the pier and not in-water), as well as the companion light (pile-supported) across the waterway (located in the water below OHWM) prior to the start of the in-water work window starting on June 15, 2015. The rationale for beginning pile extraction activities prior to the in-water work window was presented in a memorandum to the USEPA in December 2014 (Floyd|Snider 2014b). A total of four 18-inch-diameter steel piles will be removed using vibratory methods.

The vibratory pile installation activities for eight piles will occur over approximately 5 calendar days and will be installed after the start of the in-water work window.

2.3.1 Best Management Practices

To minimize the potential for adverse water quality impacts during the removal and installation of steel piles for in-water platform activities, the following BMPs will be implemented:

- During steel pile removal and installation, any accumulated debris will be collected daily and disposed of at an approved upland site.
- Piles will not be placed in or adjacent to vegetated shallows, wetlands, or special aquatic sites, or within sites designated by WDFW as documented or suitable forage fish spawning areas.
- Hydraulic water jets will not be used to remove or place piles.

2.4 VIBRATORY PILE EXTRACTION

The demolition of the existing timber-pile-supported fender system will include dismantling the existing chocks and wales and removing approximately 87 14-inch-diameter creosote-treated timber piles and 22 20-inch-diameter steel pipe piles by means of a vibratory hammer or by pulling with a choke chain. This will result in the removal of approximately 141 square feet of over-water coverage from the removal of the fender piles. The demolition of the existing concrete piles will include removing approximately 1,047 16.5-inch-diameter concrete piles waterward of OHWM by means of a vibratory hammer or by pulling with a choke chain. Piling located within the dredge prism will be removed prior to the start of the dredge activities. This will result in a total removal of 1,784 square feet of over-water coverage for all piles including: concrete, creosote-treated timber, and steel pipe piles.

Pile extraction activities will be conducted below OHWM and will occur within a time period of approximately 100 calendar days. Pile extraction is proposed to occur 1 month prior to the start of the in-water work window, on June 15, 2015, to reduce the chances that a work extension would be needed to complete remedial dredging within one season and to accommodate NMFS' stated concern that the greatest effects may occur when contaminated sediments are removed. Accordingly, NMFS recommended dredging sediments during the beginning of the in-water work window, well before the early Chinook salmon out-migrants would be present. The rationale for beginning pile extraction activities prior to the in-water work window was presented in a memorandum to the USEPA (Floyd|Snider 2014b).

2.4.1 Best Management Practices

To minimize the potential for adverse water quality impacts during the removal of the creosote and concrete piles, the following BMPs will be implemented:

- During removal of creosote-treated piles, containment booms and absorbent sausage booms (or other oil-absorbent fabric) will be placed around the perimeter of the work area to capture wood debris, oil, and other materials released into marine waters.

- The piles will be extracted in a controlled and slow manner to minimize turbidity in the water column as well as sediment disturbance.
 - The crane operator will “wake up” or vibrate the piles to break up the bond with sediment prior to extraction.
- Extraction equipment (i.e., vibratory hammer) must be kept out of the water to prevent pinching creosote-treated timber piling below the water line.
- Piling will not be broken off intentionally by twisting, bending, or other deformation, which could release creosote to the water column.
- Removed creosote-treated piles will be disposed of in a manner that precludes their further use. Piles will be cut into manageable lengths (4 feet or less) for transport and disposal in an approved upland location that meets liner and leachate standards (Chapter 173-304 of the Washington Administrative Code [WAC], Minimum Functional Standards).
- All pre-stressed concrete piles and steel pipe piles designated for demolition shall be completely removed by pulling. Jetting is not permitted.
- Existing timber piles will be completely removed by vibratory pulling. Piles that cannot be fully extracted and break during pulling shall be cut off 3 feet below mudline and the hole backfilled with clean sand. The position of each pile that breaks during pulling shall be recorded and submitted to the Port. Depending on the location of the broken pile, it may be removed at a later date in coordination with the Port and USEPA to avoid or minimize resuspension of contaminated materials. The means and method of pile retrieval is subject to approval of the Port and USEPA. Jetting and grubbing to remove the piles will not be allowed.
- Upon removal from the substrate, the pile shall be moved expeditiously from the water into a containment basin, located within a barge or on land and will be subject to the conditions of the Phase 1 Removal Action Stormwater Pollution Prevention Plan (SWPPP) and no turbid water will be released to the Blair Waterway. The pile shall not be shaken, hosed-off, stripped or scraped off, left hanging to drip, or subjected to any other action intended to clean or remove adhering material from the pile while over water.
- All accumulated debris (including cut-up piling, sediments, construction residue, and construction material from the containment basin) will be collected daily and disposed of at an approved upland site, and no treated wood will be reused.

2.5 DREDGING

Approximately 49,000 CY of TBT-contaminated sediment, as well as approximately 2,300 CY of clean riprap slope armor and 9,000 CY of underlying clean suitable sediment, will be dredged by means of a mechanical standard clamshell or digging bucket dredge modified with a “top hat” on a floating derrick barge creating approximately 23,000 square feet of open water. The dredging

activities will be below the OHWM and are expected to occur over approximately 140 days; 19 days for clean and suitable top of slope sediment dredging and survey and up to 126 calendar days for TBT-contaminated sediments, followed by surveying, confirmational sampling, and potential sand placement, if necessary. The estimated duration for TBT-contaminated dredging includes initial required dredging and up to two additional dredge passes.

The Port's proposal to conduct the dredging of TBT-contaminated sediments beginning no earlier than August 2015, after the removal of the upslope clean material, will further reduce potential impacts to the tail end of the out-migrating juvenile salmonids.

The riprap rock armor overlying the clean sediments will be removed and disposed of at an appropriate upland facility or reused by the Port for bank repairs throughout the tideflats. A small quantity (approximately 300 CY) will be used for slope stabilization in the vicinity of the electrical substation, as described in Section 3.0 of the RAWP. The Pier 4 Phase 1 Removal Action Plan SWPPP will have conditions that no turbid water may be released to the Blair Waterway. Any excess soil and water in the upland area of the clean riprap stockpiles will be controlled by means of an appropriate combination of perimeter controls and segregation of stormwater run-on/runoff and no turbid water will be released back to the waterway. A survey will be required to confirm the design depth has been achieved prior to dredging the remaining clean sediment for open water disposal.

2.5.1 Best Management Practices

2.5.1.1 Dredging of Approximately 9,000 CY Clean Sediment

To minimize the potential for adverse water quality impacts during dredging activities within the top of slope clean 9,000 CY (and riprap removal, if appropriate), prior to the dredging of TBT-contaminated sediments, the following BMPs will be implemented:

- Clean dredging will be conducted during the WDFW-approved in-water work window for Commencement Bay (July 16 to February 14).
- BMPs in Section 2.5.1.2 related to turbidity control (excluding hot spot specific BMPs) will be employed during dredging of clean sediment and riprap removal.
- Following removal of the overlying pier structure and riprap during the beginning of dredging, a visual inspection of the clean material to be dredged will be conducted by verifying depth and visually monitoring the dredged material on the barge to ensure there is no debris present at the surface of the dredge prism.
- If the dredging is conducted at dusk or at night, the Contractor shall ensure that sufficient light is provided for visual monitoring of the dredge prism for turbidity and visual inspection for debris or large rocks within the disposal barge.

2.5.1.2 *Dredging of Approximately 49,000 CY TBT-Contaminated Sediment*

To minimize the potential for adverse water quality impacts during dredging activities within the TBT-contaminated 49,000 CY, the following BMPs will be implemented:

- Dredging of TBT-contaminated sediments will occur no earlier than August 2015, which will further reduce potential impacts to the tail end of the out migrating juvenile salmonids per WDFW's recommendation.
- Dredging of contaminated sediment is restricted to occur subsequent to dredging of clean sediment to avoid residual depositing on the clean sediment surface.
- Horizontal control for dredging operations will be achieved by careful tracking of clamshell bucket positions using an electronic positioning system (Differential Global Positioning System [DGPS]) that provides real-time display and tracking of the horizontal position of the dredge bucket to be in compliance with the authorized dredge depths. The Port will work closely with the Contractor to achieve compliance with the designed dredge depths and boundaries of TBT-contaminated sediments and non-contaminated or clean underlying sediments.
- Dredging will be conducted from the top of slope, down along the slope at a stable grade in order to prevent undermining/sloughing of the dredge prism.
- Due to the presence and co-location of the riprap rock armor, the Port will require the dredging Contractor to use an extra heavy bucket that has the added weight and ability to close on the rock armor. This will facilitate the bucket jaws fully closing, thereby minimizing the chance of rock preventing the bucket from closing and minimizing turbidity and possible TBT-contaminated sediment releases to the water column.
- The Contractor will be required to confirm the bucket is closed prior to hoisting the bucket to the water surface.
- The digging bucket will be modified with a plastic or steel-fabricated "top hat" or lid that will effectively close off the top of the dredge bowls and minimize sediment loss as the bucket is raised through the water column.
- If it becomes apparent that the bucket may be over-penetrating the sediments, then the bucket speed approaching sediment will be reduced (preventing sediment from becoming piled on top of the bucket then eroding during retrieval).
- If elevated turbidity is observed at the early warning stations, the cycle time for the hoisting and lowering of the bucket will be reduced as necessary to come into compliance.
- During dredging of the two hot spot areas (as defined in the RSER [Floyd|Snider 2014a] and approved by USEPA) a boom-supported curtain will be used to provide sediment containment around the immediate vicinity of the dredge bucket

- to minimize water quality impacts and residual travel distances. The curtain will also exclude fish from entering during active dredging of the hot spot.
- Stockpiling of material below OHWM will not be allowed (i.e., each time the bucket is closed it will be brought to the surface).
 - Dredging will be done using a multiple pass dredge approach to avoid incomplete removal of contaminated sediments and to increase sediment capture and reduce residuals.
 - Dredging will be sequenced to avoid swinging the dredge bucket over "dredged-to-clean" areas and, after working down the slope, dredge higher levels of TBT contamination first (e.g., hot spot areas), as feasible.
 - The Contractor will ensure that the bucket is completely emptied of sediments over the disposal scow before re-submerging the bucket in the waterway.
 - Disposal scows (with water-tight bin walls or fences) used for transporting dredged material will not be overfilled to the point where recovered sediment or associated water overflows directly back to the waterway.
 - Material will be placed into the disposal scows without splashing material out of the barge.
 - A disposal scow with water-tight bin walls or fences to contain material and associated water, and allowing no overflow or discharge of turbid water, will be used and sediments and water will be contained.
 - Disposal scows, flat barges, and other floating equipment shall be operated to minimize nearshore propeller-wash impacts such as suspension of nearshore sediments.
 - The Port and its Contractor will conduct both interim-dredge bathymetric surveys and post-dredge bathymetric surveys to ensure that the material located within the dredge boundaries of TBT-contaminated sediments was removed to the proper, authorized extents and depths.
 - Post-dredge confirmational sampling will be conducted to confirm that the removal action achieved the project objectives and completion requirements (refer to Appendix A for details), as well as to provide sufficient analytical data to determine that the underlying sediment that is within the Phase 2 Project dredge prism is suitable for either open water disposal or beneficial use in support of a separate DMMP suitability determination.

2.6 TRANSLOADING

TBT-contaminated dredged material will be moved by water-tight scows to the transload site at APM Terminals (the Transload Site) and transferred to shore for processing (Figure 5.6 of the RAWP). APM Terminals was chosen as the preferred transload site because, in addition to having

the necessary criteria for a suitable transload and dewatering site, it meets the two criteria that are required to consider it part of the CERCLA Phase 1 Removal Action site: (1) it is Port-owned, and (2) it is contiguous with the Phase 1 Removal Action site footprint. Because it is part of the Phase 1 Removal Action site, the transloading and dewatering activities are exempt from state and local permits.

APM Terminals is located on the west site of the Sitcum Waterway, with the western edge adjacent to the Milwaukee Waterway Habitat Area. Approximately 7 acres of APM Terminal's facility will be used as the Transload Site to process, dewater, and stockpile the contaminated dredge material for upland disposal. As shown on Figure 5.7 of the RAWP, there are five catch basins; four drain to the east and one drains to the south. All catch basins will be plugged prior to site use to ensure dewatering process water and stormwater falling on the Transload Site do not enter APM Terminal's existing stormwater collection system. The Transload Site is fully paved with asphalt that is 4 inches thick. Any significant cracks will be sealed prior to starting the transload and dewatering activities. Existing 4-inch deck drains will also be plugged to prevent all process water from entering the Sitcum Waterway during transloading activities. Access to the Transload Site will be secure and will run through APM Terminals with cooperation with the terminal operator. Transportation Worker Identification Card (TWIC) credentials will be required for unescorted access to the Transload Site. Water and power will be available to the Contractor during transloading activities.

The Contractor will be required to protect the existing fender system along the APM Terminal pier, as it is designed for berthing container ships, not barges. This may require installation of up to 10 steel piles along the pier face for barge berthing. If pile installation is necessary, it would occur after the start of the in-water work window and BMPs identified under Section 2.3 would apply. If piles are installed, they will be removed prior to the end of the in-water work window and BMPs identified under Section 2.4 would apply.

Once transferred to shore from the disposal scow, sediments will be stockpiled within a confined area and dewatered. Transfer, stockpile, and load-out areas will be designed to collect leachate (from dredging or rainwater) for treatment prior to disposal, as discussed in Section 2.7 below. The Contractor selected to perform the construction activities will be subject to the requirements and procedures specified in the RAWP and the construction bid documents regarding transloading.

All dredged material placed at the Transload Site must pass the paint filter test before being loaded and trucked off-site. The stockpiles shall be built on an engineered drainage system that will allow the dredged material to have a drying agent mixed in or that will allow for passive dewatering. All drained water shall be collected in an adjacent settling basin and treated in a contractor-designed water treatment facility. Water quality monitoring will be performed per the WQMPP and water will be discharged into the waterway. Once sufficiently dried and/or stabilized for trucking, sediments will be loaded into road-trucks for off-site disposal at the LRI Landfill at Graham, Washington.

2.6.1 Best Management Practices

To minimize the potential for adverse water quality impacts during transloading activities, the following BMPs will be implemented.

2.6.1.1 Contractor Submittal

The Contractor shall prepare a Transload, Transport, and Disposal (TTD) Contractors Work Plan for review and approval by the Agencies at least 60 days prior to dredging, which will include (but not be limited to) the BMPs indicated below. The TTD shall include a Stormwater Pollution Prevention Plan (SWPPP) for operation of the Transload Site that shall meet National Pollutant Discharge Elimination System (NPDES) substantive requirements. Because this work is being conducted as a Time Critical Removal Action under USEPA's authority, an NPDES permit will not be required as long as substantive requirements for NPDES are met. Use of the TDD may not commence until approved by the Agencies.

BMPs Related to Barge Transit

- Barges transiting from the Phase 1 dredge area to the Transload Site shall contain all material, water or sediment, during transit. Dewatering from the barge into the waterway is not allowed.
- Dredged material shall not be piled above barge sidewalls at any time during transit.

BMPs Related to Unloading of Sediment from the Barges at the Transload Site

- There shall be no passive dewatering from the barge into the waterway.
- Wharf decking and all surfaces that can come in contact with dredged sediment and associated water shall be made of solid (no slats), impermeable materials. The Contractor shall be prepared to block and pump the wharf area during transloading if rainwater accumulates.
- Sheeting or equivalent impermeable lining shall be placed under the travel area of the bucket to capture any spills. In the event there are any spills outside of the area covered by the sheet, the spilled material shall be cleaned up immediately.
- Dockside sediment control (e.g., sweeper truck, shoveling, sweeping, wash down) shall occur as often as necessary to avoid the tracking of sediment by vehicles and personnel and to generally maintain a clean site, and shall include the dock, transload area, and the haul routes.
- Transfer of dredged material shall occur in a fashion that minimizes splash and splatter of the material.
- There shall be no path for material to fall into the water during off-loading operations. Spill aprons or other containment devices shall be used to prevent the release of spilled material into the water between the barge and the dock.

- Spill aprons shall be impermeable, uninterrupted, and structurally adequate to catch any falling material, including rain water, and hold or deflect it back into a contained area, either on shore or on the barge.
 - The spill apron shall be wide enough that caught material or water will not fall off the sides.
 - Material shall not be allowed to accumulate on the spill apron.
 - The spill apron must be able to provide protection throughout the full tidal range.
- The Transload Site must have the ability to keep the barge tied up close to the dock during tidal fluctuations.

BMPs Related to Stormwater Management at the Transload Site

- The Contractor shall prepare a SWPPP for the Transload Site as a component of the TTD that describes operational and structural source control BMPs related to barge material transloading. The SWPPP will be available for review by all involved or interested agencies. The SWPPP shall ensure that the transload operations are in substantive compliance with NPDES requirements.
- The SWPPP shall describe the routing and ultimate disposal of any water from the dredged material, all stormwater collected within the dredged material handling area, any water that is used for wash-down of trucks and equipment, and any water that may come in contact with the dredged material or dredged material handling equipment. All water management at the Transload Site shall meet the requirements of both the approved SWPPP and the WQMPP. All stormwater that comes into contact with dredged material or dredged material handling equipment shall be treated in accordance with the WQMPP. All stormwater falling into or entering the transload area shall be treated in accordance with the WQMPP.
- The SWPPP shall discuss the design storm criteria and shall also discuss the contingency for overflows in excess of the design storm and controls to minimize stormwater contributing to the sediment dewatering process.

BMPs Related to Containment and Treatment of Water Generated during Transloading

- Dredged material handling and dewatering shall take place in an exclusion zone that prevents dredged water and sediment from entering the site's stormwater system. The use of the existing catch basins as drainage sumps is allowed as long as all piping into the catch basins is plugged and the catch basins are watertight. Dredged water and sediment is not allowed to enter stormwater piping.
- The dredged water treatment system shall have a discharge system that is completely separate from the site's stormwater system.

- After completion of the transload operation, the surrounding work area shall be washed and the wash water captured and treated via the dredge water treatment system.

BMPs Related to Transport of Off-Loaded Material

- Dredged material shall be sufficiently dewatered to pass the LRI Landfill paint filter test prior to transporting from the Transload Site.
- All truck loads shall be water-tight and covered to prevent loss of material during transport.
- Loading of the trucks shall take place within an exclusion zone, which will be established to contain any spilled material that may occur while loading. All loads will be inspected to ensure that no dredged materials are on the outside of the truck, and that the loads are covered and not leaking during transit.
- A wheel wash(s) shall be installed immediately adjacent to the outbound gate of the transload area. If necessary, the exterior of the trucks shall be swept of excess material prior to leaving the loading area. Any spilled dredged material and water generated from cleaning the exterior of the trucks will be treated on-site.
- Loading practices (e.g., partially loading to provide freeboard; loading near centerline of truck bed) shall be employed to prevent spillage.

BMPs Related to Stockpiling Material On-Site

- It is anticipated that handling and dewatering of dredged material may require the use of short-term surge-piles and/or long-term stockpiles. If material piles must be used, then the following BMPs shall be addressed:
 - All material piles shall be located within the confines of the contained transload area to allow water to drain to the treatment system.
 - The Contractor shall visually monitor all material piles for fugitive dust and will be required to employ dust control measures if necessary.
 - All stockpiles shall be located on an impervious surface. All pavement cracks in pile areas and drainage areas shall be sealed prior to placing material.
 - Stockpile areas will be inspected daily and after high precipitation events.

BMPs Related to Spills of Dredged Material into the Water

USEPA shall be notified of the incident immediately. A memorandum shall be prepared and submitted to the Agencies describing the incident and providing specifics on the material released, possible causes, and actions taken. The location and amount of any sediment that enters the waterway shall be documented. If possible, the spilled material shall be retrieved from the waterway in the most expeditious manner possible.

2.7 DEWATERING TREATMENT SYSTEM AND DREDGE RETURN WATER

The sediment arriving at the Transload Site will contain an approximate 1:1 ratio of sediment and water, such that approximately 8 to 10 million gallons of water will need to be dewatered and treated. TBT-contaminated water will be generated from water pumped from a decant barge at the dredge site and from water collected from the upland sediment dewatering staging area at the Transload Site. Water from both sources will be treated to remove TBT to concentrations less than applicable water quality criteria prior to the points of compliance discussed in Section 3.1 below.

Approximately 150,000 to 300,000 gallons per day of water will need to be treated, which will require a treatment system capable of treatment flow rates in the 300- to 600-gallons per minute (gpm) range. The removal of dissolved TBT from the water will require a treatment train including: primary screening and settling to remove large particles; coagulation and settling; mixed-media filtration to remove total suspended solids (TSS), turbidity, and adsorbed TBT; and, finally, GAC as a final polishing step to remove dissolved TBT. The final treatment train will be customized by the Contractor, but it must be designed in accordance with the RAWP and the bid specifications. For more detailed information on the evaluation of treatment and the recommended treatment train, refer to Appendix C of the RAWP.

Compliance parameter monitoring during dredge return water discharge will include turbidity and chemical monitoring for TBT. Samples will be collected from the return water prior to discharge to the waterway. There are two levels of monitoring that will be conducted: Tier 1 Intensive and Tier 2 Routine, which are described in Section 6.0 below.

2.8 POTENTIAL POST-DREDGE SAND PLACEMENT

Following completion of dredging, it will be determined based on post-dredge confirmational sampling results whether an additional dredge pass is needed in the hot spot areas or if placement of clean material (i.e., clean sand) for dredge residuals management is needed, as described in Appendix A. Sand may also be placed along the waterward perimeter of the dredge prism. If needed, a layer approximately 1 foot thick would be placed in thin lifts. The volume of sand material to be placed would be between 300 and 600 CY in the central hot spot and between 50 and 100 CY in the southern hot spot; the volume of sand to be placed along the waterward perimeter of the dredge prism would depend on the affected area. The sand layer would be below the final elevation for the Phase 2 Project, or outside of the planned dredge prism, and would not be affected by Phase 2 dredging. All sand placement would be completed within the 2015 to 2016 in-water work window.

Following sand placement, the final surface elevations will be verified by bathymetric survey. Water quality monitoring will be conducted during material placement to ensure that water quality is not impacted at the point of compliance, as described in Section 5.0. Material placement will be conducted following BMPs described in Section 2.8.1.

2.8.1 Best Management Practices

Clean sand material will be provided from a source location that meets the chemical and physical requirements of the bid specifications.

During fill placement activities, the following BMPs will be implemented to minimize impacts to the waterway:

- Materials will meet project specifications regarding grain size and fines content to minimize the potential for elevated turbidity in receiving waters during placement.
- Material will be placed by controlled release from a clamshell bucket. Materials will be uniformly discharged as a stream of material, as opposed to being abruptly discharged, in order to provide for uniform bottom coverage and minimize impacts to the receiving surface.
- Material will be placed from less than 10 feet above the mudline depth to limit sediment disturbance and suspension.

2.9 CONCRETE TEST PILE PROGRAM

Following completion of the pier demolition and dredging of the TBT-contaminated sediments, the site will be rebuilt during Phase 2 of the project (which includes reconfiguration of the pier). To facilitate this site restoration, the Port plans to perform a concrete test pile program as part of the Phase 1 Removal Action. As this work is being conducted during the Time Critical Removal Action, it will be done under USEPA oversight. The intent of the concrete test pile program is to confirm design assumptions made about installation and structural capacity of the concrete piles that will be installed to support the proposed reconfigured pier in Phase 2. The program will consist of installing four 24-inch-diameter octagonal concrete piles along the length of the Pier 4 slope and will record data associated with the amount of energy required to drive each pile. The piles will be driven using an impact hammer and will be instrumented to collect the necessary data. The concrete test pile program will be conducted below the project-specific OHWM and will occur over a period of approximately 12 days and will occur within the 2015 to 2016 in-water work window. Pile installation may occur concurrent with dredging; however, piles must be installed and removed only in areas where contaminated sediments have been completely removed and confirmational sampling has been completed. All test piles will be extracted and properly disposed of upon completion of testing.

2.9.1 Best Management Practices

To minimize the potential for adverse water quality impacts during the installation and removal of the concrete test piles, the following BMPs will be implemented:

- Piles must be installed and removed only in areas where contaminated sediments have been completely removed and confirmational sampling has been completed.

- During concrete pile installation and removal, any accumulated debris will be collected daily and disposed of at an approved upland site.
- Piles will not be placed in or adjacent to vegetated shallows, wetlands, or special aquatic sites, or within sites designated by WDFW as documented or suitable forage fish spawning areas.
- A wooden block will be placed on top of the pile during all pile driving to protect the pile and attenuate underwater noise.
- Hydraulic water jets will not be used to install or remove piles.

This page intentionally left blank.

3.0 Water Quality Monitoring Objectives and Standards

The objective of water quality monitoring is to ensure that near-water, in-water, and over-water activities, do not result in exceedances of the applicable water quality standards at the point(s) of compliance. A combination of instrumented, visual, and chemical TBT monitoring is proposed for this project (Figures B.3 and B.4). Water quality monitoring consisting of either turbidity monitoring and/or chemical monitoring will be conducted for the in-water construction phases of the project, as described in Section 5.0 and the dredge return water management activities, as described in Section 6.0.

3.1 WATER QUALITY STANDARDS

3.1.1 Turbidity

The water quality monitoring turbidity standards applicable to this site per WAC 173-201A-210(1)(e) are as follows:

- Turbidity shall not exceed 10 Nephelometric Turbidity Units (NTUs) over the background turbidity when the background turbidity is less than 50 NTUs.
- Turbidity shall not exceed a 20 percent increase in turbidity when the background turbidity is more than 50 NTUs.

For water quality monitoring of dredge return water, background turbidity is assumed to be 0 NTUs.

3.1.1.1 *Points of Compliance for Removal of the Pier Structure, Pile Extraction, Pile Installation, Dredging, Potential Post-Dredge Sand Placement, and Concrete Test Pile Placement and Removal*

The water quality standard for turbidity will need to be met at the Compliance Boundary at the edge of the authorized mixing zone for all construction activities except dredge return water monitoring, as described in Section 3.1.1.2. The turbidity water quality standard includes an allowed 150-foot mixing zone that extends out from the in-water activity or Near-Field Dredging Zone, as described in Section 5.1. The water quality monitoring for turbidity will be conducted at the acute 150-foot-boundary point of compliance (i.e., the Acute Compliance Boundary) per the aquatic use criteria (WAC 173-201A-210(1)(e)(i)). In addition, visible turbidity greater than the background turbidity at or beyond the Acute Compliance Boundary (150-foot boundary) is considered an exceedance of the water quality standard. Water quality monitoring for turbidity will also be conducted at the chronic 300-foot-boundary point of compliance (i.e., the Chronic Compliance Boundary).

3.1.1.2 *Points of Compliance for Dredge Return Water Monitoring*

For dredge return water monitoring, the water quality standard for turbidity will need to be met at the sampling port at the end of the return water treatment system (end-of-pipe) acute point

of compliance (i.e., Acute Compliance Station). Water quality monitoring for turbidity will be conducted at the end-of-pipe Acute Compliance Station for comparison to acute and chronic water quality criteria, and will be conducted at the chronic 150-foot-Chronic Compliance Station if acute water quality criteria are exceeded at the Acute Compliance Station. In addition, visible turbidity at or beyond the end-of-pipe Acute Compliance Station is considered an exceedance of the water quality standard.

3.1.2 Narrative Water Quality Standards

In addition to the numerical standards for turbidity described above, the project will also comply with narrative water quality standards, which include the following:

- No visible petroleum sheen on water observed at the construction site.
- No distressed or dying fish observed at the construction site that can be attributed to activities at the construction site.

These narrative criteria are not subject to the requirement for a mixing zone and, therefore, must be met throughout the project area.

3.1.3 Water Quality Criteria for Tributyltin

The compliance criteria for TBT will include both acute and chronic water quality criteria. The analytical reporting limits for the chemical analysis of dissolved TBT¹ in water quality grab samples will be less than the criteria, as shown in Table B.1. The results of water quality grab samples will be compared to the appropriate water quality standard, as described below.

3.1.3.1 Acute Criterion

During dredging, water quality grab samples collected at the 150-foot Acute Compliance Boundary, when triggered (refer to Section 5.0), will be compared to the USEPA acute marine aquatic life water quality criterion for dissolved TBT of 0.42 micrograms per liter ($\mu\text{g/L}$; USEPA 2003), as shown on Table B.1. For dredge return water monitoring, samples collected at the end-of-pipe Acute Compliance Boundary will also be compared to the USEPA acute criterion of 0.42 $\mu\text{g/L}$. The acute criterion is implemented as a 1-hour average, not to be exceeded more than once every 3 years on the average.

3.1.3.2 Chronic Criterion

During dredging, water quality grab samples collected at the 300-foot Chronic Compliance Boundary, when triggered (refer to Section 5.0), will be compared to the USEPA chronic marine

¹ Due to the potential for TBT scavenging via adsorption to the surface of a filter, a sample representative of the dissolved fraction of TBT will be obtained by centrifugation of the water samples prior to analysis. This methodology is consistent with the procedures used to obtain a dissolved TBT result during Dredge Elutriate Testing conducted as part of the Removal Site Evaluation. This analysis will be referred to in the following sections as "dissolved TBT."

aquatic life water quality criterion for dissolved TBT of 0.0074 µg/L (USEPA 2003) as shown on Table B.1. For dredge return water monitoring, samples collected at the 150-foot Chronic Compliance Boundary, when triggered, will also be compared to the USEPA chronic criterion of 0.0074 µg/L. The chronic criterion is implemented as a 4-day average, not to be exceeded more than once every 3 years on the average.

3.1.4 Performance Standard for pH

During dredge return water treatment, pH will be measured in real time within the treatment system and adjusted, as necessary, prior to reaching the acute point of compliance. The selected performance standard for the treated dredge return water is a pH range of 7 to 8.5 standard units (refer to Appendix C).

This page intentionally left blank.

4.0 Types of Monitoring

Monitoring, either visual, instrumented, or chemical, will be done during all over-water and in-water work activities. In-water work is defined as work below the tide elevation at the time of the activity. The Contractor will submit weekly water quality monitoring reports during all in-water work and dredge return water discharge.

4.1 VISUAL MONITORING

Throughout all in-water work and over-water work, the Contractor will conduct visual monitoring of turbidity. A turbidity plume is considered significant when it is above background. Visual monitoring will be performed during all the following construction activities:

- Removal of the pier structure (over-water demolition work)
- Vibratory pile extraction
- Installation of piling
- Impact hammer installation and vibratory extraction of concrete test piling
- Removal and reuse of riprap and dredging of clean sediments
- Dredging of contaminated sediments
- Potential post-dredge sand placement following confirmational sampling
- Dredge return water discharge

4.1.1 Visual Monitoring Parameters

The following parameters will be observed during visual monitoring:

- Turbidity (visual indication of plume)
- Sheen or oil
- Construction debris in water
- Distressed or dying fish
- Operation and effectiveness of BMPs

4.2 INSTRUMENTED MONITORING

Turbidity will be monitored with a water quality meter during the following construction activities:

- Vibratory pile extraction
- Installation of piling
- Removal and reuse of riprap below the tide elevation

- Dredging of clean and contaminated sediments
- Impact hammer installation and vibratory extraction of concrete test piling
- Potential post-dredge sand placement following confirmational sampling
- Dredge return water discharge

Instrumented monitoring will also be implemented in response to visual observation of a significant turbidity plume to better assess compliance with the water quality criteria and the effectiveness of any supplemental BMPs that may be implemented to control turbidity.

pH will also be monitored within the dredge return water treatment system during return water treatment and discharge.

4.3 CHEMICAL TRIBUTYLTIN MONITORING

During dredging of TBT-contaminated sediments, water quality grab samples will be collected for chemical analysis of dissolved TBT during the first week of dredging, during all hot spot dredging, and if a turbidity exceedance during Tier 2 Routine monitoring triggers transition back to Tier 1 Intensive (as described in Section 5.0). During dredge return water monitoring, water quality grab samples will be collected and analyzed for dissolved TBT, as described in Section 6.0.

5.0 Monitoring Plan during all In-water Activities

5.1 MONITORING STATIONS

During all in-water activity monitoring stations described below will be measured from the point of construction activity, with the exception of hot spot dredging. During hot spot dredging, which will occur within an approximately 60-foot by 60-foot floating boom-supported curtain, a Near-Field Dredging Zone will be established at the boundary of the curtain and the monitoring stations will be measured from the edge of the Near-Field Dredging Zone.

- 1. Early Warning Stations.** There will be two monitoring stations at this distance, along the 100-foot boundary from the construction activity or Near-Field Dredging Zone (if hot spot dredging). The stations will be located both down-current/downgradient and up-current/upgradient from the construction activity in order to capture the two-layer tidally influenced flow or split-flow. The objective of monitoring at the Early Warning Stations is to have an early indication of whether exceedances of the water quality standards may occur at the Acute Compliance Boundary. Any NTU that exceeds the water quality criteria at this point will be referred to as an “elevation” at the early warning point. If an elevation is confirmed, BMPs should be implemented to avoid an actual exceedance at the point of compliance.
- 2. Acute Compliance Stations.** There will be two monitoring stations at this distance, along the 150-foot boundary and edge of the mixing zone measured from the construction activity or Near-Field Dredging Zone (if dredging). The stations will be located both down-current/downgradient and up-current/upgradient from the construction activity in order to capture the two-layer tidally influenced flow or split-flow. The objective of monitoring at the Acute Compliance Stations is to take turbidity measurements and water quality grab samples for TBT chemical analysis, and, if exceedances are confirmed, the project will temporarily shut down and implement additional BMPs to achieve compliance with water quality criteria.
- 3. Chronic Compliance Stations.** There will be two monitoring stations at this distance, along the 300-foot boundary from the construction activity or Near-Field Dredging Zone (if dredging). The stations will be located both down-current/downgradient and up-current/upgradient from the construction activity. Turbidity monitoring will be conducted at the Chronic Compliance Stations and water quality grab samples will be collected for TBT chemical analysis to compare to the chronic TBT criterion when triggered by chemical exceedances of the acute TBT criterion at the Acute Compliance Stations or exceedances of turbidity during dredging, as described in Section 5.3.
- 4. Background Stations.** There will be two background monitoring stations, Background 1 and Background 2. Background 1 will be positioned a minimum of 400 feet up-current/upgradient from the construction activity or Near-Field Dredging Zone (if hot spot dredging) and beyond the influence of construction activities. The objective of the Background 1 monitoring station is to determine if background

conditions may be contributing to exceedances at the project site. Background 2 will be positioned at the mouth of the Blair Waterway and will serve to capture and identify any potential turbidity influx from the Puyallup River plume or other outside sources. Both background monitoring stations will be monitored during every event because the turbidity standard is based on comparison with background levels. Additionally, water samples may be collected and archived here for potential TBT analysis, if triggered and as described below in Section 5.5.

The actual positions of the Early Warning, Acute Compliance, Chronic Compliance, and Background Stations will be adjusted based on the location of active in-water work, the tidal cycle, and observations of the direction of the current.

During the first day that the dredging is conducted inside the silt curtain (i.e., hot spot dredging), the Contractor will perform a series of turbidity measurements below the silt curtain depth in the vicinity of the dredging operations to inform the locations of the downstream and upstream monitoring stations. At least 10 turbidity measurements will be collected around the perimeter of the construction activity and documented on the water quality form. If an elevation of turbidity is noted, the Contractor will attempt to determine the direction the plume is migrating by collecting additional turbidity measurements surrounding the area where elevated turbidity was observed. If a turbidity plume is confirmed, the positions of the Early Warning, Acute Compliance, and Chronic Compliance Stations will be adjusted to align with the presumed direction that the plume is migrating.

5.2 MONITORING DEPTHS

Monitoring will be conducted at three depths in the water column at each station described above:

1. Surface—Within 3 feet (approximately 1 meter) of the water surface
2. Middle—At mid-depth in the water column
3. Bottom—Within 3 feet (approximately 1 meter) of the mudline

The water depths to be monitored were chosen to be representative of Background and Compliance Boundary conditions because, as shown during 2014 current meter deployment and measurement, the Blair Waterway within the vicinity of Pier 4 exhibits split layer flow that varies with the tidal cycle (e.g., during ebb tides upper layer flow is outward from the Blair Waterway versus flow that moves inward to the Blair Waterway in the lower layer). Sample measurements from each of the three depths will be compared to each of the three corresponding depths at all compliance and background monitoring stations.

5.3 TIER 1—INTENSIVE WATER QUALITY SCHEDULE DURING TBT-CONTAMINATED DREDGING

The steps to be followed for Tier 1 Intensive monitoring are shown in Table B.2 and Figure B.5. Tier 1 Intensive monitoring will be implemented during the first 7 days of TBT-contaminated

dredging and during all hot spot dredging. Tier 1 Intensive monitoring includes turbidity monitoring twice daily on each of the 7 days and collection of water quality grab samples once daily (during the second event of the day) on each of the 7 days. However, chemical analysis of the water quality grab samples for dissolved TBT is initially conducted only at the Acute Compliance Station and depth with greatest turbidity measurements on Days 1, 3, and 5, and the water quality grabs collected on the remaining days of the first week are archived for potential analysis, only if needed based on turbidity results or chemical analysis of the other samples (as described in Sections 5.3.1 and 5.3.2). Tier 1 Intensive monitoring will also be conducted if an exceedance of turbidity during Tier 2 Routine monitoring during TBT-contaminated dredging triggers a transition back to Tier 1 Intensive monitoring. The first of the daily monitoring events (for turbidity only) will begin at least 1 hour after the start and continuous operation of the monitored construction activity. The second daily monitoring event will be separated from the first event by at least 4 hours, and will begin at least 1 hour after the start and continuous operation of the monitored construction activity (e.g., not after lunch break or stop in activity to move barge, etc.). All Tier 1 Intensive monitoring will be conducted during daylight hours. If, due to late start up time for the day, only one sample is taken during the day, then both turbidity and water quality samples will be taken at that sampling event.

If an exceedance of turbidity is observed at an Acute or Chronic Compliance Station, monitoring will be paused for up to 15 minutes, while background turbidity conditions are confirmed, and the turbidity measurement at the Acute or Chronic Compliance Station is re-taken. If turbidity still exceeds the water quality compliance criterion, it will be considered a confirmed exceedance and the steps presented in Figure B.5 and described below in Section 5.5 will be followed.

If there are no exceedances of water quality criteria (i.e., turbidity and TBT chemistry) after 7 days of Tier 1 Intensive monitoring, then monitoring may be reduced to the Tier 2 Routine monitoring schedule.

5.3.1 Turbidity Compliance

Twice per day during Tier 1 Intensive monitoring while dredging, turbidity measurements will be taken at all Early Warning, Acute Compliance, Chronic Compliance, and Background Stations. Turbidity will be measured at the Background Stations first, prior to the Early Warning or Acute and Chronic Compliance Stations. Turbidity measurements from each of the three depths at each of the stations will be compared to each of the three corresponding depths at the Background Stations. If a turbidity exceedance is confirmed to be from construction activity at an Acute or Chronic Compliance Station, the Contractor will temporarily shut down work, modify operations, and implement additional BMPs, as necessary, to get turbidity into compliance. The contractor will notify the Port Project Manager and the Port Project Manager will notify USEPA. USEPA will be notified within 2 hours of the turbidity exceedance and turbidity monitoring will be conducted every 2 hours for the remainder of the day during daylight dredging until compliance is documented or as directed otherwise by USEPA. Additionally, a confirmed turbidity exceedance at a Compliance Station will trigger the restarting of the Tier 1 Intensive schedule. For example,

if a confirmed turbidity exceedance is documented on Day 5 of dredging, the monitoring schedule will start back at Day 1 and continue for a period of 7 days.

If a turbidity exceedance is confirmed during the first monitoring event of the day, water quality grab samples will be collected as described in Section 5.3.2 until turbidity and TBT compliance is demonstrated, in addition to the responses described above.

5.3.2 Tributyltin Compliance

During the second daily monitoring event in the first 7 days of TBT-contaminated dredging and dredging within the hot spot areas (or whenever a return to Tier 1 Intensive monitoring is triggered), water quality grab samples for dissolved TBT will be collected at all Compliance Stations (Acute and Chronic) and both Background Stations at all depths (for a total of 18 water quality grab samples collected per day). On Days 1, 3, and 5, the water quality grab sample from the Acute Compliance Station and depth with the highest turbidity measurement will be analyzed for dissolved TBT. The remaining samples collected from Days 1, 3, and 5, as well as the water quality grabs collected on Days 2, 4, 6, and 7, will be archived pending the results of the analyzed discrete samples, and other samples may be analyzed per the outcomes of turbidity and chemical results, as described below in Section 5.5 and shown in Figure B.5

5.4 TIER 2—ROUTINE WATER QUALITY SCHEDULE FOR ALL IN-WATER ACTIVITIES

The steps to be followed for Tier 2 Routine monitoring are shown on Table B.2 and Figure B.6 and include turbidity monitoring, but do not include any chemical TBT monitoring. Tier 2 Routine monitoring will be implemented for all in-water activities (i.e., vibratory pile extraction, installation of piles, dredging, riprap removal and reuse, and potential post-dredge sand placement) at a frequency of twice daily measurements, 2 days per week (separated by at least 1 day between). During dredging, Tier 2 Routine monitoring will be conducted whenever Tier 1 Intensive monitoring is not required. The first of the daily monitoring events will begin at least 1 hour after the start and continuous operation of the construction activity. The second monitoring event will be separated from the first event by at least 4 hours, and again will begin at least 1 hour after the start and continuous operation of the monitored construction activity.

5.4.1 Turbidity Compliance

Twice per day and 2 days per week during Tier 2 Routine monitoring, turbidity measurements will be taken at all Early Warning, Acute Compliance, Chronic Compliance, and Background Stations during Tier 2 Routine monitoring. Turbidity will be measured at the Background Stations first, prior to the Early Warning or Acute and Chronic Compliance Stations. Turbidity measurements from each of the three depths at each of the stations will be compared to each of the three corresponding depths at the Background Stations.

If an elevation of turbidity is confirmed at an Early Warning Station, the Contractor should pause work, adjust BMPs and then re-measure the turbidity at the Early Warning Stations. If an

exceedance of turbidity is observed at a Compliance Station (Acute or Chronic), monitoring will be paused for up to 15 minutes while background turbidity conditions are confirmed, and the turbidity measurement will be re-taken.

If the turbidity exceedance is confirmed at an Acute or Chronic Compliance Station to be from construction activity, it will trigger a return to Tier 1 Intensive monitoring (if dredging), and the Contractor will temporarily halt work, modify operations, and implement additional BMPs, as necessary, to get turbidity into compliance. If this occurs during vibratory pile extraction, a water quality grab sample will also be collected for dissolved TBT analysis at the location of the highest turbidity exceedance to determine if there is a correlation between turbidity and TBT concentrations. The Contractor will notify the Port Project Manager and the Port Project Manager will notify USEPA. USEPA will be notified within 2 hours of the turbidity exceedance. Concurrent with a return to Tier 1 Intensive monitoring, turbidity monitoring will be conducted every 2 hours for the remainder of the day during daylight hours until compliance is documented or as directed otherwise by USEPA.

5.5 RESPONSES TO ELEVATIONS AT THE EARLY WARNING POINT OR EXCEEDENCES OF COMPLIANCE CRITERIA DURING TIER 1 INTENSIVE MONITORING

5.5.1 Turbidity at the Compliance Stations

5.5.1.1 *Turbidity Elevation is Observed at an Early Warning Station*

If an elevation of turbidity is observed at the Early Warning Boundary (100-foot monitoring location), the following steps will be taken:

1. Verify turbidity equipment is working.
2. Compare to Background 1 and Background 2 measurements to determine whether exceedance is due to construction activities or ambient waterway conditions.
3. Take a second measurement at the Early Warning Boundary to confirm elevation.
4. If elevation is confirmed to be from construction activity, the contractor will modify operations and implement additional BMPs.
5. Take another turbidity measurement an hour after implementing BMPs to verify effectiveness of BMPs.
6. Continue with Tier 1 Intensive Monitoring.

5.5.1.2 *Turbidity Exceedance is Confirmed at an Acute Compliance Station*

If a turbidity exceedance is confirmed at an **Acute Compliance Station** (150-foot monitoring boundary), the following steps will be taken:

1. The Contractor will notify the Port Project Manager and the Port Project Manager will notify USEPA. USEPA will be notified within 2 hours of turbidity exceedance.

2. The Contractor will pause work, modify operations, and implement additional BMPs, as necessary to bring turbidity into compliance. Work will not restart until turbidity is in compliance.
3. Turbidity monitoring will be conducted every 2 hours for the remainder of the day during daylight dredging until compliance is documented or as directed otherwise by USEPA.
4. Restart 7-day schedule of Tier 1 Intensive monitoring and water quality grab sampling.
5. Tributyltin chemical analysis of water samples will be performed as described in Section 5.5.2.1.

5.5.1.3 Turbidity Exceedance is Confirmed at a Chronic Compliance Station

If a turbidity exceedance is confirmed at a Chronic Compliance Station but not at an Acute Compliance Station, the Contractor will notify the Port Project Manager and the Port Project Manager will notify USEPA. USEPA will be notified within 2 hours of the turbidity exceedance and will coordinate with the Contractor to determine whether an exceedance at the Chronic Compliance Station unaccompanied by an exceedance at the Acute Compliance Station is associated with the work. The Contractor will pause operations and implement additional BMPs, as necessary to bring turbidity into compliance. Turbidity monitoring will be conducted every 2 hours for the remainder of the day during daylight dredging until compliance is documented or as directed otherwise by USEPA. At that time, Tier 1 Intensive monitoring will be restarted to confirm compliance and allow work to proceed.

If a turbidity exceedance is confirmed at a Chronic Compliance Station and an Acute Compliance Station, the same steps will be followed as described above; however, the Contractor will cease operations and work may only resume at the express direction of USEPA, after the activity contributing to the turbidity has been corrected, and water quality conditions are in compliance with water quality standards.

Simultaneous to steps above, if a turbidity exceedance is confirmed at a **Chronic Compliance Station** (300-foot monitoring boundary), TBT chemical analysis of water samples will be performed as described in Section 5.5.2.2.

5.5.2 Tributyltin at the Compliance Stations

5.5.2.1 Tributyltin Chemical Analysis Results for Acute Water Quality Samples

5.5.2.1.1 Outcome 1—Tributyltin does not Exceed Acute or Chronic Criterion

If the dissolved TBT analytical result from the **Acute Compliance Station** with the greatest turbidity as measured on Days 1, 3, and 5 does not exceed the acute or chronic criterion, complete the first week of the Tier 1 Intensive schedule and proceed with Tier 2 Routine monitoring per water quality schedule.

5.5.2.1.2 Outcome 2—Tributyltin does not Exceed Acute Criterion, but is Greater than Chronic Criterion

If the discrete dissolved TBT analytical result from the **Acute Compliance Station** with the greatest turbidity as measured on Days 1, 3, and 5 does exceed the **chronic** criterion but does not exceed the **acute** criterion, the following steps will be taken:

1. Composite the water quality grabs archived from the Chronic Compliance Stations and depths (e.g., six samples in total) from the day of the TBT exceedance. Composite the water quality grabs from all the Chronic Compliance Stations each day, for three additional consecutive days. Analyze the first day for dissolved TBT and archive the remaining 3 days.
 - a. Compare the TBT concentration from the first day's composite to the chronic compliance criterion. If the first day composite TBT sample result does not exceed the chronic criterion, continue with the first week of Tier 1 Intensive schedule and proceed with Tier 2 Routine monitoring per water quality schedule.
 - b. If the first day composite TBT sample result does exceed the chronic criterion, analyze each of the composites from the subsequent 3 consecutive days and compare the 4-day average of the results to the chronic compliance criterion.
 - i. If the average TBT sample result does not exceed the 4-day chronic criterion, complete the first week of the Tier 1 Intensive schedule and proceed with Tier 2 Routine monitoring per water quality schedule.
 - ii. If the average TBT sample result does exceed the chronic criterion, **a compliance criterion exceedance has occurred** and the following steps must be performed:
 1. Upon receipt of analytical data, the Contractor will notify the Port Project Manager and the Port Project Manager will notify USEPA. USEPA will be notified within 4 hours of receipt of data indicating a TBT exceedance.
 2. Adjust/implement BMPs and consult with the Contractor, Port Project Manager, and USEPA.
 3. Restart Tier 1 Intensive monitoring and water quality grab sampling for a period of 7 days unless TBT results from subsequent Tier 1 Intensive monitoring days do not exceed the criterion.

Simultaneous to Step 1, composite six archived water quality grab samples from Background Stations from day of exceedance and analyze for dissolved TBT for informational purposes, if needed.

5.5.2.1.3 Outcome 3—Tributyltin does Exceed the Acute Criterion

If the dissolved TBT analytical result from the **Acute Compliance Station** with the greatest turbidity as measured on Days 1, 3, and 5 does exceed the **acute** criterion, the following steps will be taken:

1. Composite the six archived water quality grab samples from the day of the discrete exceedance that were collected from the Acute Compliance Stations (all depths) and analyze for dissolved TBT.
2. Compare the TBT concentration of the composite sample to the acute compliance criterion.
 - a. If the composite TBT result does not exceed the acute criterion, complete the first week of the Tier 1 Intensive schedule and proceed with Tier 2 Routine monitoring per water quality schedule.
 - b. If the composite TBT result does exceed the acute criterion, a **compliance criterion exceedance has occurred** and the following steps must be performed:
 - i. Upon receipt of analytical data, the Contractor will notify the Port Project Manager and the Port Project Manager will notify USEPA. USEPA will be notified within 4 hours of receipt of data indicating a TBT exceedance.
 - ii. Adjust/implement BMPs and consult with the Contractor, Port Project Manager, and USEPA.
 - iii. Restart Tier 1 Intensive monitoring and water quality grab sampling for a period of 7 days unless TBT results from subsequent Tier 1 Intensive monitoring days do not exceed the criterion.

5.5.2.2 Tributyltin Chemical Analysis Results for Chronic Water Quality Samples

If a turbidity exceedance is confirmed at a **Chronic Compliance Station** (300-foot monitoring boundary), the following steps will be taken:

1. Analyze the water quality grab sample (already being collected per Tier 1 Intensive monitoring requirements) from the Chronic Compliance Station at the depth of the exceedance for TBT. Continue to collect water quality grabs from this depth for the next 3 days, and archive at the laboratory. If the first day TBT sample result does not exceed the chronic criterion, complete the first week of Tier 1 Intensive schedule and proceed with Tier 2 Routine monitoring per water quality schedule.
2. If the first day result exceeds the chronic criterion, analyze the remaining 3 days' results and compare the average to the chronic compliance criterion.
 - a. If the average TBT sample result does not exceed the chronic criterion, complete the first week of Tier 1 Intensive schedule and proceed with Tier 2 Routine monitoring per water quality schedule.

- b. If the average TBT sample result does exceed the chronic criterion, **a compliance criterion exceedance has occurred** and the following steps must be performed:
- i. Upon receipt of analytical data from the laboratory, the Contractor will notify the Port Project Manager and the Port Project Manager will notify USEPA. USEPA will be notified within 4 hours of receipt of data indicating a TBT exceedance.
 - ii. Adjust/implement BMPs and consult with the Contractor, Port Project Manager, and USEPA.

This page left intentionally blank.

6.0 Monitoring Plan during Dredge Return Water Monitoring

6.1 MONITORING STATIONS

Compliance parameter monitoring during dredge return water discharge will include turbidity and chemical TBT monitoring. Samples will be collected from the return water prior to discharge to the waterway. There are two levels of monitoring that will be conducted: intensive and routine.

1. **Acute Compliance Station.** There will be one station located at the end-of-pipe of the treatment system, prior to the treated water conveyance pipe that discharges via an outfall to the waterway. The objective of monitoring at the Acute Compliance Station is to take water quality composite samples for turbidity measurement and TBT chemical analysis, and, if exceedances are confirmed, evaluate and implement additional BMPs for the dredge return water treatment system to achieve compliance with water quality criteria.
2. **Chronic Compliance Stations.** There will be two monitoring stations at this distance, along the 150-foot boundary from the outfall discharge point. The monitoring stations will be located both down-current/downgradient and up-current/upgradient from the construction activity. Water quality grab samples will be collected for TBT chemical analysis to compare to the chronic TBT criterion, only if triggered by exceedances of the turbidity standard or chemical exceedances of the acute TBT criterion at the Acute Compliance Station, as described in Section 6.5.

The actual positions of the Chronic Compliance Stations will be adjusted based on the location of the outfall discharge point, the tidal cycle, and observations of the direction of the current.

6.2 MONITORING DEPTHS

Monitoring of the end-of-pipe Acute Compliance Station is expected to occur through an inline sampling port connected to the discharge piping prior to the point of discharge; therefore, there is no depth associated with this location. For the Chronic Compliance Stations, monitoring will be conducted at three depths in the water column:

1. Surface—Within 3 feet (approximately 1 meter) of the water surface
2. Middle—At mid-depth in the water column
3. Bottom—Within 3 feet (approximately 1 meter) of the mudline

The water depths to be monitored were chosen to be representative of near-surface, mid-water column and near-bottom conditions within the water column.

6.3 TIER 1—INTENSIVE WATER QUALITY SCHEDULE

The steps to be followed for Tier 1 Intensive monitoring are shown on Table B.3 and Figure B.7. Intensive monitoring will be implemented daily during the first 7 days of the dredge return water treatment system operation during TBT-contaminated dredging and daily the entire time that sediment from the hot spot area dredging is dewatered. Discharge of dredge return water from hot spot dredging will be contingent on the result of chemical TBT analysis, as described in Section 6.3.2. Tier 1 Intensive monitoring will also be conducted if an exceedance of turbidity during Tier 2 Routine monitoring triggers a transition back to Tier 1 Intensive monitoring. Tier 1 Intensive monitoring at the Chronic Compliance Station, if required, will be conducted during daylight hours.

The Phase 1 dredging sequence includes the removal of the 9,000 CY clean (non-TBT-contaminated) sediments from the top of slope, followed by the removal of lower-level TBT-contaminated sediments from the slope, as described in the RAWP. Influent (pre-treatment) TBT concentrations are projected to be relatively low during the initial dredging, and should be much less than the acute criterion of 0.42 µg/L at the end-of-pipe Acute Compliance Station. Samples will be collected from the influent and effluent of the treatment system at 20 minute intervals, composited over 1 hour, and submitted for the analysis of dissolved TBT (described in Section 6.3.2) with an anticipated 4-day turnaround time. The analytical results will provide an opportunity to verify treatment system performance and make system adjustments, if needed, prior to subsequent treatment of the dredge return water associated with hot-spot dredging.

If an exceedance of turbidity is observed in an end-of-pipe Acute Compliance Station effluent water composite sample, monitoring will be paused for up to 15 minutes, while the measurement is re-taken and turbidity is measured in the discrete samples comprising the composite. If there are no exceedances of water quality criteria (i.e., turbidity and TBT chemistry) after seven days of Tier 1 Intensive monitoring, then monitoring may be reduced to the Tier 2 Routine monitoring schedule.

6.3.1 Turbidity Compliance

Each day during Tier 1 Intensive monitoring during dewatering treatment system operation and dredge return water discharge, water quality samples will be composited every 20 minutes over a 1-hour period in both the daily influent and end-of-pipe effluent and turbidity will be measured in each composite sample. The composite samples will be homogenized and the composite sample container will be agitated prior to measuring turbidity and filling bottles for chemical analysis. The water quality samples collected on Days 1, 3, and 5 will be analyzed for dissolved TBT, as described below in Section 6.3.2. The remaining daily samples will be archived and only analyzed pending the results of the analyzed samples and daily turbidity measurements. Influent and end-of-pipe effluent turbidity measurements will be compared to evaluate the treatment system performance and will be compared to the turbidity water quality criteria.

If a turbidity exceedance is confirmed in an effluent 1-hour composite from the end-of-pipe Acute Compliance Station, discharge will immediately cease and the Contractor will notify the Port Project Manager and the Port Project Manager will notify USEPA. USEPA will be notified within 2 hours of the turbidity exceedance and the corrective actions described in Section 8.2 will be implemented. Additionally, the steps presented in Section 6.5 and shown in Figure B.7 will be followed. If a sudden or steady increase in turbidity with total NTUs less than the water quality monitoring standard is observed, corrective actions including dredge return water treatment system inspection, maintenance and modification, as described in Section 8.2, and re-testing for turbidity will also be conducted.

After system evaluation and BMP adjustments, turbidity will be re-measured while the treatment system is in recirculation (no discharge mode) to confirm effectiveness. In consultation with USEPA, the treatment system will resume discharge after confirmation that the turbidity is in compliance and Tier 1 Intensive monitoring will be restarted for a period of 7 days.

6.3.2 Tributyltin Compliance

During Tier 1 Intensive monitoring the influent and end-of-pipe effluent water quality samples composited over a 1-hour period collected on Days 1, 3, and 5 (described in Section 6.3.1) will be submitted for analysis of dissolved TBT with an anticipated 4-day turnaround time. The dissolved TBT results of the effluent samples will be compared to the acute criterion. If the concentrations of dissolved TBT at the end-of-pipe are less than the TBT acute criterion, then there are no exceedances of the compliance criteria and no further analyses are required. During the Tier 1 Intensive monitoring period for hot spot dredging, dredge return water may be discharged only after receipt of chemical analytical results confirming that the TBT concentration in the end-of-pipe water quality sample collected on Day 1 is less than the TBT acute criterion; prior to receipt of Day 1 TBT results, the dredge return water treatment system will not discharge to receiving water. Section 6.5 and Figure B.7 describe the steps to be taken if analysis of these samples is triggered.

6.4 TIER 2—ROUTINE WATER QUALITY SCHEDULE

The steps to be followed for Tier 2 Routine monitoring are shown on Table B.3 and Figure B.8. Tier 2 Routine monitoring for turbidity will be conducted twice a week on non-consecutive days when Tier 1 Intensive monitoring is not required. Water quality samples will be taken over a 1-hour period in the daily influent and end-of-pipe effluent and composited separately and measured for turbidity. Turbidity of the end-of-pipe Acute Compliance Station effluent composite water quality samples (1-hour) will be compared to the turbidity water quality standard.

If a turbidity exceedance is confirmed in an effluent 1-hour composite from the end-of-pipe Acute Compliance Station, discharge will immediately cease and the Contractor will notify the Port Project Manager and the Port Project Manager will notify USEPA. USEPA will be notified within 2 hours of the turbidity exceedance and the corrective actions described in Section 8.2 will be implemented. Also, the water quality composite from the effluent end-of-pipe sample will be analyzed for dissolved TBT. After system evaluation and BMP adjustments, turbidity

measurements and dissolved TBT analysis will be conducted while the treatment system is in recirculation (no discharge mode) to confirm effectiveness. In consultation with USEPA, the treatment system will resume discharge after confirmation that water quality criterion for turbidity can be achieved and Tier 1 monitoring will be restarted and conducted for a period of 7 days to demonstrate compliance with water quality criteria.

6.5 RESPONSES TO EXCEEDANCES OF COMPLIANCE CRITERIA DURING TIER 1 INTENSIVE MONITORING

6.5.1 Turbidity at the Acute Compliance Station

6.5.1.2 *Turbidity is Confirmed in the End-of-Pipe Effluent at the Acute Compliance Station*

If a turbidity exceedance is confirmed at the **Acute Compliance Station** (end-of pipe), the following steps will be taken:

1. Immediately cease discharge of treatment system.
2. Upon confirmation of a turbidity exceedance, the Contractor will notify the Port Project Manager and the Port Project Manager will notify USEPA. USEPA will be notified within 2 hours of turbidity exceedance.
3. Implement corrective actions described in Section 8.2.
4. After system evaluation and potential system and BMP adjustments, re-sample effluent turbidity while the treatment system is in recirculation (no discharge) mode to confirm effectiveness.
5. Resume treatment system discharge after NTU meets criteria in recirculation mode and restart Tier 1 Intensive monitoring until turbidity water quality criterion compliance is demonstrated for 7 consecutive days, or as directed by USEPA.

Simultaneous to Step 2 above, perform the following:

1. Collect water quality grab samples at the Chronic Compliance Stations (150-foot boundary) at all three depths and composite. Then, composite the water quality grabs from both Chronic Compliance Stations each day, for 3 additional consecutive days. Analyze the first day for dissolved TBT and archive the remaining 3 days.
2. Compare the TBT concentration from the first day's composite to the chronic compliance criterion.
 - a. If the first day composite TBT sample result does not exceed the chronic criterion, complete the additional week of Tier 1 Intensive schedule as described above and proceed with Tier 2 Routine monitoring per the water quality schedule.
 - b. If the first day composite TBT sample result does exceed the chronic criterion, analyze each of the composites from the subsequent 3 consecutive days and compare the 4-day average of the results to the chronic compliance criterion.

- i. If the 4-day average TBT sample result does not exceed the chronic criterion, complete the additional week of Tier 1 Intensive schedule as described above and proceed with Tier 2 Routine monitoring per water quality schedule.
- ii. If the 4-day average TBT sample result does exceed the chronic criterion, **a compliance criterion exceedance has occurred** and the following steps must be performed:
 1. Immediately cease discharge of the treatment system.
 2. Upon receipt of analytical data, the Contractor will notify the Port Project Manager and the Port Project Manager will notify USEPA. USEPA will be notified within 4 hours of receipt of data indicating a TBT exceedance.
 3. Implement corrective actions described in Section 8.2.
 4. After system evaluation and potential system and BMP adjustments, re-sample effluent turbidity while the treatment system is in recirculation (no discharge) mode to confirm effectiveness of responses.
 5. Resume treatment system discharge (unless otherwise directed by USEPA) and re-sample Chronic Compliance Boundary TBT by collecting daily samples at two points along the Chronic Compliance Boundary (150 feet from outfall) for 4 days and compare the 4-day average concentration to the TBT chronic criterion.
 6. Restart Tier 1 Intensive monitoring until TBT acute (end-of-pipe) and chronic (Compliance Boundary) water quality criterion compliance is demonstrated for 7 consecutive days or as directed by USEPA, unless TBT results from subsequent Tier 1 Intensive monitoring days do not exceed the criterion.

6.5.2 Tributyltin Results for Acute Water Quality Samples from End-of-Pipe Effluent

6.5.2.1 Outcome 1—Tributyltin does not Exceed Acute or Chronic Criterion

If the dissolved TBT analytical results from effluent composite samples at the **Acute Compliance Station**, as measured on Days 1, 3, and 5, do not exceed the acute or chronic criterion, complete the first week of the Tier 1 Intensive schedule and proceed with Tier 2 Routine monitoring per water quality schedule.

6.5.2.2 Outcome 2—Tributyltin in End-of-Pipe Effluent does not Exceed Acute Criterion, but is Greater than Chronic Criterion

If a dissolved TBT analytical result from an effluent 1-hour composite from the end-of-pipe **Acute Compliance Station** on Days 1, 3, and 5 does exceed the **chronic** criterion but does not exceed the **acute** criterion, the following steps will be taken:

1. Collect water quality grab samples at the Chronic Compliance Stations (150-foot boundary) at all three depths and composite. Then, composite the water quality grabs from both Chronic Compliance Stations each day, for 3 additional consecutive days. Analyze the first day for dissolved TBT and archive the remaining 3 days.
2. Compare the TBT concentration from the first day's composite to the chronic compliance criterion.
 - a. If the first day composite TBT sample result does not exceed the chronic criterion, Complete the first week of the Tier 1 Intensive schedule and proceed with Tier 2 Routine monitoring per water quality schedule.
 - b. If the first day composite TBT sample result does exceed the chronic criterion, analyze each of the composites from the subsequent 3 consecutive days and compare the 4-day average of the results to the chronic compliance criterion.
 - i. If the composite TBT sample result does not exceed the chronic criterion, complete the first week of the Tier 1 Intensive schedule and proceed with Tier 2 Routine monitoring per water quality schedule.
 - ii. If the composite TBT sample result does exceed the chronic criterion, **a compliance criterion exceedance has occurred** and the following steps must be performed:
 1. Immediately cease discharge of treatment system.
 2. Upon receipt of analytical data, the Contractor will notify the Port Project Manager and the Port Project Manager will notify USEPA. USEPA will be notified within 4 hours of receipt of data indicating a TBT exceedance.
 3. Implement corrective actions described in Section 8.2.
 4. After system evaluation and potential system and BMP adjustments, re-sample effluent turbidity while the treatment system is in recirculation (no discharge) mode to confirm effectiveness of responses.

5. Resume treatment system discharge (unless otherwise directed by USEPA) and re-sample Chronic Compliance Boundary TBT by collecting daily samples at two points along the Chronic Compliance Boundary (150 feet from outfall) for 4 days and compare the 4-day average concentration to the TBT chronic criterion.
6. Restart intensive monitoring until TBT acute (end-of-pipe) and chronic (Compliance Boundary) water quality criterion compliance is demonstrated for 7 consecutive days or as directed by USEPA.

6.5.2.3 Outcome 3—Tributyltin in End-of-Pipe Effluent does Exceed the Acute Criterion

If the dissolved TBT analytical result from an effluent composite sample from the **Acute Compliance Station** on Days 1, 3, and 5 does exceed the **acute** criterion, a **compliance criterion exceedance has occurred** and the following steps must be performed:

1. Immediately cease discharge of treatment system.
2. The Contractor will notify the Port Project Manager and the Port Project Manager will notify USEPA. USEPA will be notified within 4 hours of receipt of data indicating a TBT exceedance.
3. Perform system inspection and maintenance as described in Section 8.2.
4. After system evaluation and potential system and BMP adjustments, re-sample effluent (end-of-pipe) turbidity and TBT while the treatment system is in recirculation (no discharge) mode to confirm effectiveness of the responses.
5. Resume treatment system discharge once compliance with acute criteria is demonstrated (unless otherwise directed by USEPA). Restart Tier 1 Intensive monitoring until TBT acute water quality criterion compliance is demonstrated for 7 consecutive days or as directed by USEPA.

This page intentionally left blank.

7.0 Water Quality Compliance Monitoring Methods

7.1 MONITORING EQUIPMENT

Equipment to be used for the turbidity and TBT water quality monitoring will include the following:

- Water quality meter: HACH 2100Q, Troll 9500, YSI 6920 Sonde (or other suitable equipment)
- Depth sounder or lead line
- Water sampler: Van Dorn, Niskin bottle, or equivalent
- Field logbook
- Deionized water for rinsing water quality monitoring equipment
- Personal protective equipment
- Camera
- Cellular phone and project contact phone numbers

Turbidity levels will be measured with a water quality meter, which will be properly operated, calibrated, and maintained by qualified personnel before each use according to the manufacturer's guidelines and recommendations. All field analyses will be recorded in a logbook and the specific person who calibrated the equipment will be recorded.

7.2 POSITIONING METHODOLOGY

All locations will be positioned using a laser rangefinder or a DGPS onboard the sampling vessel to determine an accurate distance from the construction activity. The accuracy of the location control will be +/- 10 feet.

7.3 WATER QUALITY MONITORING AND SAMPLING METHODOLOGY AT LOCATIONS WITHIN THE WATERWAY

For turbidity monitoring during construction activities or dredge return water discharge at locations within the waterway, the water quality meter will be lowered to the appropriate water depth and be allowed to equilibrate for approximately 30 seconds and the final turbidity measurement will be recorded on a field form. If collecting water quality grab samples for TBT chemical analysis during dredging or dredge return water discharge at compliance boundaries in the waterway, the water sampler will be lowered to the target depth and the water sample will be collected into the sampling device. Once on board the vessel, the water sample will be transferred to the appropriate bottles, capped, labeled appropriately, and placed in a cooler with ice.

7.4 MONITORING AND SAMPLING METHODOLOGY FROM THE DREDGE RETURN WATER TREATMENT SYSTEM

During dredge water return monitoring, influent and effluent water quality samples will be collected from inline sampling ports located within the treatment system piping for turbidity measurements and chemical TBT analysis, and pH will be monitored continuously within the treatment system. The effluent end-of-pipe sampling will be conducted prior to the discharge of dredge return water to the waterway.

7.5 DECONTAMINATION PROCEDURES

All sampling equipment (including the water sampler, any surfaces that could come in contact with samples collected for TBT chemical analysis, etc.) will be cleaned before the start of work and will be cleaned between each sampling location. Decontamination will be performed before each sample is collected, in accordance with standard good practices, following the procedure below:

- Rinse with clean tap water.
- Wash with brush and Alconox soap.
- Rinse with clean tap water.
- Triple rinse with distilled water.
- Do not use solvent or acid washes because of safety, rinsate disposal, and sample integrity considerations.

7.6 FIELD QUALITY ASSURANCE SAMPLES

Field quality assurance (QA) samples will be used to evaluate the efficacy of field decontamination procedures. During Tier 1 Intensive monitoring, field duplicate samples will be collected at a frequency of one per day (on Days 1, 3, and 5 of dredging and dredge return water discharge) for water samples and submitted as blind duplicates. Additional sample volume for matrix spike/matrix spike duplicate laboratory QA analysis will be collected at a frequency of 1 sample per 20 samples submitted for analysis.

Because exposure to TBT may result in possible detections due to sorption onto non-dedicated sampling equipment, a rinsate blank will be collected from non-dedicated equipment (e.g., water sampler) after the equipment has been cleaned following the decontamination procedure described in Section 7.5. A rinsate blank will be collected at a frequency of twice per week during Tier 1 Intensive monitoring. One rinsate will be collected on either of Days 1, 3, or 5 and analyzed for dissolved TBT. One rinsate will be collected on Days 2, 4, 6, or 7 and archived. Rinsate blanks will be collected by pouring laboratory-supplied deionized water over the surfaces of the equipment that have contacted sample material and collecting this rinsate water into sample bottles.

7.7 DOCUMENTATION AND USEPA REPORTING

The Contractor will retain a field logbook, prepare daily water quality monitoring forms detailing the monitoring data collection activities and results and will prepare a summary report. The Contractor shall submit the water quality monitoring forms and summary report to the Port by noon on the following Monday in which water quality monitoring occurred. The Port will verify the forms and report are filled out accurately and will submit the summary report to the USEPA On Scene Coordinator within 1 week of the completion of each week of water quality monitoring. The template for the water quality monitoring form is included in Attachment 1. These reports and the forms will include the following information:

- Date and time of the monitoring at each location
- Turbidity measurement monitoring at each monitoring location (i.e., Background, Early Warning, and Acute and Chronic Compliance Stations)
- Location, rationale for sampling, and turbidity measurements for any additional discretionary stations that are sampled in order to evaluate a potential turbidity plume
- Water quality monitoring results
- Name of monitoring personnel
- Monitoring notes that may include:
 - Field conditions (weather, temperature, any prior disturbance of the waterbody, etc.)
 - Monitoring equipment calibration information
- Description of construction activity taking place, duration of activity, and any modifications to the activity that may have occurred prior to sample collection

7.8 LABORATORY TRIBUTYL TIN ANALYSIS AND QUALITY CONTROL

7.8.1 Laboratory Analysis Protocols

Water quality monitoring samples will be analyzed for dissolved TBT. Due to the potential for TBT scavenging via adsorption to the surface of a filter, a sample representative of the dissolved fraction of TBT will be obtained by centrifugation of the water samples prior to analysis. This methodology is consistent with the procedures used to obtain a dissolved TBT result during Dredge Elutriate Testing conducted as part of the Removal Site Evaluation. Table B.4 outlines the method, sample preservation, bottle type, and sample holding times for TBT. Table B.5 identifies data quality objectives (DQOs) for precision, accuracy, and completeness.

7.8.2 Limits of Detection

The target method reporting limit for dissolved TBT using low-level analysis by the Krone method of 0.0052 µg/L is less than the chronic criterion of 0.0074 µg/L. All reasonable means, including

additional cleanup steps and method modifications, will be used to bring the limits of detection to less than 0.0074 µg/L.

7.8.3 Quality Assurance/Quality Control

The chemistry QA/quality control (QC) procedures will follow Puget Sound Estuary Program and the QA/QC criteria established for the Puget Sound Dredged Disposal Analysis (PSDDA)/DMMP programs.

Surrogates will be required for every sample, including matrix spike samples, blanks, laboratory control samples, and standard reference materials. Matrix spikes/matrix spike duplicates will be required for every 20 samples received. Matrix triplicates are analyzed for conventional parameters.

All samples will be diluted and re-analyzed if target compounds are detected at levels that exceed their respective established calibration ranges. Any cleanups will be conducted prior to the dilutions. Re-analyses will be performed if surrogate, internal standard, or spike recoveries are outside of the DQO parameters. QC samples may be re-analyzed if results are not within control limits and it cannot be determined that the sample matrix is the cause.

8.0 Corrective Actions and Notification Plan

There are two types of corrective actions that could be implemented, depending on the nature of the water quality impact or exceedance: (1) modifications of operations, and (2) cessation of operations. If water quality criteria are exceeded, the appropriate steps will be taken to identify and correct the problem. If corrective actions do not result in an improvement in water quality at the compliance stations, construction activities may be halted at the direction of USEPA.

8.1 CORRECTIVE ACTIONS DURING IN-WATER WORK

If an exceedance of a water quality standard occurs at any monitoring station during either visual or instrumented monitoring, or during both, field personnel will temporarily stop work and assess the source of the exceedance or impact, and corrective actions will be evaluated. Once the source has been identified, field personnel will implement operation modifications or other supplemental control measures or BMPs to bring the water quality measurements back into compliance with the criteria. Corrective actions to be implemented during dredging may include, but are not limited to the following:

- Pausing operations to confirm that the dredge bucket is properly functioning and there are no repairs needed to the floating-boom-supported curtain.
- Modifying dredge procedures during the following situations:
 - If it becomes apparent that the bucket may be over-penetrating the sediments, then the bucket speed approaching the sediment will be reduced to prevent sediment from becoming piled on top of the bucket, which could erode during retrieval.
 - In the event that turbidity results are excessive, the cycle time for the hoisting and lowering of the bucket will be reduced, as necessary, to come into compliance.

Other corrective actions may be identified through examination of the work practices and conditions. Once the control measures have been deemed effective, monitoring will continue until the water quality exceedances have been brought into compliance.

8.2 CORRECTIVE ACTIONS DURING DREDGE RETURN WATER MONITORING

As described in Section 6.3, water quality criteria exceedances are not anticipated because influent (pre-treatment) TBT concentrations are projected to be relatively low during the initial dredging, and should be much less than the acute criterion of 0.42 µg/L at the end-of-pipe Acute Compliance Station. The dredge return water pH is also expected to fall within the system performance standard range, and any pH measurements outside of this range will be corrected within the treatment system prior to the Acute Compliance Station and no further corrective action will be needed. In the event of an exceedance of turbidity or TBT water quality criteria, treatment system discharge will immediately be stopped, the Contractor will notify the Port Project Manager and the Port Project Manager will notify and consult with USEPA (within 2 hours

for a turbidity exceedance and within 4 hours of receipt of analytical data that indicated an exceedance of TBT water quality, and the following responses will be initiated:

- Review system turbidity monitoring data and other relevant control system information to evaluate effectiveness of treatment system component.
- Inspect the following system components:
 - Settling tanks
 - Electrocoagulation system
 - Mixed media filters
 - Other filter or clarifying units
 - GAC system
- Perform maintenance and system modifications as warranted.
- Re-sample end-of-pipe effluent turbidity while the treatment system is in the recirculation (no discharge) mode to confirm effectiveness of the operational changes.
- Based on results of re-sampling, implement one or more of the following, if needed:
 - Perform additional adjustments to electrocoagulation system operation to improve effectiveness.
 - Switch GAC units from parallel to series operation and add additional GAC vessels, if needed, to increase GAC contact time.
 - Replace GAC in one or more vessels.
 - Re-sample end-of-pipe turbidity again to confirm that changes have been effective and that water quality criteria compliance can be achieved.
- Resume treatment system discharge unless otherwise directed by USEPA.

8.3 CESSATION OF ACTIVITIES

Some conditions require a stop-work response and these conditions are as follows:

- The first indication of significant oil sheen in the vicinity of construction activity, outside of the containment boom.
- The first indication of distressed or dying fish in the vicinity of the construction activity.
- A turbidity exceedance is confirmed at either an Acute Compliance Station or a Chronic Compliance Station.
- A turbidity or TBT exceedance is confirmed in an effluent 1-hour composite from the end-of-pipe Acute Compliance Station.

If sheen or oil, or debris, is observed in the waterway, the Contractor will immediately cease operations. Corrective actions will be implemented to make repairs to equipment, address the

spill, or modify construction activities or BMPs, and conduct appropriate notifications with the Port and USEPA. Work may resume after the corrective actions have been deemed effective, the turbidity complies with the water quality standard, and as directed by the Port or USEPA.

If distressed or dying fish are observed at the construction site that can be attributed to construction activities, work will stop immediately and the Contractor will immediately notify the Port Project Manager and the Port Project Manager will immediately notify USEPA immediately.

8.3 NOTIFICATION

If compliance monitoring data indicate an exceedance of the water quality standard for turbidity, the Contractor will notify the Port Project Manager and the Port Project Manager will notify USEPA. USEPA will be notified within 2 hours of a turbidity exceedance. If a chemical exceedance occurs, and upon receipt of analytical data, the Contractor will notify the Port Project Manager and the Port Project Manager will notify USEPA. The USEPA will be notified of a chemical exceedance within 4 hours of receipt of data indicating a TBT exceedance. If evidence of noncompliance, such as distressed or dying fish or a discharge of oil, is noted at a compliance monitoring location, the Port will be notified immediately. The Port will notify the USEPA On-Scene Coordinator, Kathy Parker, by phone, (360) 553-0062, or email, Parker.Kathy@epa.gov, as well as the USEPA Water Quality Specialist, Erika Hoffman, by phone (360) 753-9540, or email, Hoffman.Erika@epa.gov.

The notification should include the following:

1. A description of the nature, extent, and cause of noncompliance.
2. The period of noncompliance, including the date, time, and anticipated time when the activity will return to compliance
3. The steps taken to minimize, eliminate, and prevent a reoccurrence of the noncompliance action.
4. A written report to USEPA within 5 days of the noncompliance that provides a description of the nature of the violation, the sampling results and location, photographs, a description of the BMPs that were or will be implemented to prevent further violations, and any other pertinent information.

This page intentionally left blank.

9.0 References

- Confluence Environmental Company. (Confluence). 2014. Pier 4 Ordinary High Water Mark (OHWM) Determination Memorandum. Memorandum from Marlene, Meaders, Chris Berger, and Chris Czesla, Confluence Environmental Company, to Mark Rettmann, Port of Tacoma. 11 August.
- Floyd|Snider. 2014a. *Removal Site Evaluation Report. Pier 4 Phase 1 Removal Action Project*. Prepared for Port of Tacoma. 25 September.
- _____. 2014b. *Memorandum Re: Rationale Supporting Pile Extraction Prior to July 15, 2015 In-water Work Window*. 15 December.
- U.S. Environmental Protection Agency (USEPA). 2003. *Ambient Aquatic Life Water Quality Criteria for Tributyltin (TBT) – Final*. Office of Water. EPA 822-R-03-031. December.

**Pier 4 Phase 1 Removal
Action Project**

Removal Action Work Plan

**Appendix B
Water Quality Monitoring and
Protection Plan**

Tables

**Table B.1
Tributyltin Analytical Method and Target Quantitation Limit**

Chemical	Unit	USEPA Marine Aquatic Life Water Quality Criteria ²		Analytical Method	Method Reporting Limit
		Acute	Chronic		
		Dissolved Tributyltin—as TBT ion (Aqueous) ¹	µg/L		

Notes:

- 1 The dissolved fraction of TBT will be obtained by centrifugation of the water sample, rather than filtration, prior to analysis. This method minimizes the risk of TBT scavenging by the laboratory equipment.
- 2 The dissolved TBT concentrations will be compared to the USEPA acute marine aquatic life water quality criterion for TBT of 0.42 µg/L (USEPA 2003) at the 150-foot acute point of compliance boundary (Acute Compliance Stations) for dredging and at the end-of-pipe of the treatment system (Acute Compliance Station) for dredge return water monitoring. Additionally, per the monitoring schedule, when water quality grab sampling is required at the Chronic Compliance Stations (300 feet from dredging activities or near-field dredging zone if during hot spot dredging), dissolved TBT concentrations will be compared to the USEPA chronic marine aquatic life water quality criterion for TBT of 0.0074 µg/L. For dredge return water monitoring, samples collected at the 150-foot Chronic Compliance Stations, when triggered, will also be compared to the USEPA chronic criterion of 0.0074 µg/L.
- 3 All water quality grab samples will be analyzed for dissolved TBT using a low-level analysis to achieve a reported result less than the acute and chronic marine aquatic life water quality standards (0.42 µg/L and 0.0074 µg/L, respectively).

Abbreviations:

- µg/L Micrograms per liter
- TBT Tributyltin
- USEPA U.S. Environmental Protection Agency

Table B.2
Water Quality Monitoring Schedule and Requirements for all In-Water Activities

Tier 1—Intensive Monitoring	Tier 2—Routine Monitoring
<p>Duration: First 7 days of TBT-contaminated dredging, during all hot spot dredging, or if there is a turbidity exceedance during Tier 2 Routine monitoring during TBT-contaminated dredging, which triggers a return to Tier 1 Intensive.</p>	<p>Duration: 2 days per week during pile extraction and installation, riprap removal below the tide elevation, dredging of clean sediments, potential post-dredge sand placement, then 2 days per week during dredging when Tier 1 Intensive during dredging is not required.</p>
<p>Frequency: Twice daily, 7 days.</p>	<p>Frequency: Twice daily; 2 days per week.</p>
<p>Locations:</p> <p>Early Warning Stations (100-foot boundary): Two stations downcurrent/downgradient and upcurrent/upgradient of construction activity</p> <p>Acute Compliance Stations (150-foot boundary): Two stations downcurrent/downgradient and upcurrent/upgradient of construction activity</p> <p>Chronic Boundary Stations (300-foot boundary): Two stations downcurrent/downgradient and upcurrent/upgradient of construction activity</p> <p>Background Locations: Background 1 will be positioned a minimum of 400 feet upcurrent/upgradient from the construction activity or Near-Field Dredging Zone (if dredging) and beyond the influence of construction activities. Background 2 will be positioned at the mouth of the Blair Waterway.</p>	<p>Locations: Same as Tier 1 Intensive monitoring.</p>
<p>Depths:</p> <ol style="list-style-type: none"> 1. Surface—Within 3 feet of the water surface. 2. Middle—At mid-depth in the water column. 3. Bottom—Within 3 feet of the mudline. 	<p>Depths: Same as Tier 1 Intensive monitoring.</p>
<p>Turbidity Monitoring: Turbidity taken at every monitoring station/event. Measure at Background Stations first.</p>	<p>Turbidity Monitoring: Same as Tier 1 Intensive monitoring.</p>
<p>TBT Monitoring: WQ samples for TBT will be collected <u>during second daily monitoring event</u> at all Compliance and Background Stations/depths. <u>On Days 1, 3, and 5 of dredging</u>, the WQ grab sample from the Acute Compliance Station/depth with the greatest measured turbidity will be analyzed for TBT. Archive remaining samples.</p>	<p>TBT Monitoring: None.</p>
<p>Turbidity Exceedance Action:</p> <p>If elevated turbidity is observed at an Early Warning Station, pause dredging and implement BMPs.</p> <p>If confirmed turbidity exceedance occurs at Acute Compliance Stations, notify Port PM/USEPA within 2 hours of turbidity exceedance. The Contractor will modify operations and implement additional BMPs. Continue turbidity monitoring every 2 hours for remainder of day until compliance is demonstrated, or directed otherwise by USEPA. Restart Tier 1 Intensive and WQ grab sampling.</p> <p>If confirmed turbidity exceedance occurs at Chronic Compliance Stations, notify Port PM/USEPA within 2 hours of turbidity exceedance. The Contractor will modify operations and implement additional BMPs (or cease if turbidity also at Acute Compliance Station). Continue turbidity monitoring every 2 hours for remainder of day until compliance is demonstrated, or directed otherwise by USEPA. Analyze WQ grab sample from the Chronic Compliance Station at depth of exceedance and analyze for TBT. Continue to analyze WQ grabs from this depth for the next 3 days. Compare TBT result from the first day’s sample to the chronic criterion. Compare the average TBT concentration of WQ grab samples to the chronic criterion. Restart Tier 1 Intensive and WQ grab sampling.</p> <ul style="list-style-type: none"> ○ If the result exceeds, a compliance criterion has occurred; notify Port PM and USEPA within 4 hours of exceedance. Adjust/implement BMPs and consult with Contractor, Port PM, and USEPA. ○ If the result does not exceed, complete first week of Tier 1 Intensive and proceed with Tier 2 Routine per WQ schedule. 	<p>Turbidity Exceedance Action:</p> <p>If confirmed turbidity exceedance at Acute or Chronic Compliance Stations, notify Port PM and USEPA within 2 hours of exceedance. Contractor will modify operations and implement additional BMPs. Continue turbidity monitoring every 2 hours for remainder of day until compliance is demonstrated, or directed otherwise by USEPA. If dredging, return to Tier 1 Intensive monitoring per WQ schedule (Figure B.5).</p> <p>If confirmed turbidity exceedance occurs at <u>both Acute and Chronic Compliance Stations</u>, the Contractor will cease operations and modify and/or implement additional BMPs. Notify Port PM and USEPA within 2 hours of exceedance. Follow the steps in Figure B.5 as guidance for confirmed exceedance at Chronic Compliance Stations.</p>

Table B.2
Water Quality Monitoring Schedule and Requirements for all In-Water Activities

Tier 1—Intensive Monitoring		Tier 2—Routine Monitoring	
<p>TBT Exceedance Action:</p>	<p>Outcome 2—If TBT discrete result is less than the acute criterion but greater than the chronic criterion, composite the WQ grabs archived from the Chronic Compliance Stations and depths (e.g., six samples in total) from the day of the acute compliance TBT exceedance. Then, composite the WQ grabs from all the Chronic Compliance Stations each day, for 3 additional consecutive days, and analyze the composite from the day of the TBT exceedance and archive the remaining 3 days. Compare the TBT concentration from the first day’s composite to the chronic criterion. If the result exceeds, compare the average TBT result of <u>all</u> composite samples to the chronic criterion.</p> <ul style="list-style-type: none"> ○ If the result exceeds, a compliance criterion has occurred; notify Port PM and USEPA within 4 hours of exceedance. Adjust/implement BMPs and consult with Contractor, Port PM, and USEPA. Restart Tier 1 Intensive and WQ grab sampling for a period of 7 days unless TBT results from subsequent Tier 1 Intensive monitoring days do not exceed the criterion. ○ If the result does not exceed, complete first week of Tier 1 Intensive and proceed with Tier 2 Routine per WQ schedule and submit weekly WQ reports. Simultaneous to this process, composite six archived WQ grab samples from Background Stations from day of exceedance and analyze for TBT for informational purposes, if needed. <p>Outcome 3—If TBT discrete result exceeds the acute criterion, composite six archived WQ grab samples from day of discrete exceedance and analyze for TBT. Compare the TBT concentration of the composite sample to the acute criterion.</p> <ul style="list-style-type: none"> ○ If the result exceeds, a compliance criterion exceedance has occurred; notify Port PM and USEPA within 4 hours of exceedance. Adjust/implement BMPs and consult with Contractor, Port PM, and USEPA. Restart Tier 1 Intensive and WQ grab sampling for a period of 7 days unless TBT results from subsequent Tier 1 Intensive monitoring days do not exceed the criterion. ○ If the result does not exceed, complete first week of Tier 1 Intensive and proceed with Tier 2 Routine per WQ schedule and submit weekly WQ reports. 	<p>TBT Exceedance Action:</p>	<p>Not applicable.</p>

Abbreviations:

- BMP Best Management Practices
- PM Project Manager
- Port Port of Tacoma
- TBT Tributyltin
- USEPA U.S. Environmental Protection Agency
- WQ Water quality

Table B.3
Water Quality Monitoring Schedule and Requirements for Dredge Return Water Monitoring

Tier 1—Intensive Monitoring	Tier 2—Routine Monitoring
Duration: First 7 days following startup of the TBT-contaminated dredging, during all hot spot dredging, or if there is a turbidity exceedance during Tier 2 Routine monitoring schedule, which triggers a return to Tier 1 Intensive.	Duration: 2 days per week during dredging when Tier 1 Intensive is not required.
Frequency: Once daily, 7 days.	Frequency: Once daily; 2 days per week.
Locations: Acute Compliance Station (End-of-Pipe of Treatment System)¹: One station located at the end-of-pipe of the treatment system, prior to the outfall discharge to the waterway. Chronic Boundary Stations (150-foot boundary): Two stations downcurrent/downgradient and upcurrent/upgradient of outfall discharge point.	Locations: Same as Tier 1 Intensive monitoring.
Depths²: <ol style="list-style-type: none"> 1. Surface—Within 3 feet of the water surface. 2. Middle—At mid-depth in the water column. 3. Bottom—Within 3 feet of the mudline. 	Depths: Same as Tier 1 Intensive monitoring.
Turbidity Monitoring: Collect daily influent and end-of-pipe effluent WQ samples that are composited over 1 hour and measure turbidity in each composite sample. Compare influent and end-of-pipe effluent turbidity measurements to evaluate the treatment system performance and compare to turbidity WQ criteria.	Turbidity Monitoring: Same as Tier 1 Intensive monitoring.
TBT Monitoring: <u>On Days 1, 3, and 5</u> , analyze collected composites from the influent and end-of-pipe effluent for TBT and archive the composite samples collected on Days 2, 4, 6, and 7.	TBT Monitoring: None.
Turbidity Exceedance Action: If confirmed turbidity exceedance in effluent end-of-pipe acute compliance sample , immediately cease discharge of the treatment system. Notify Port PM/USEPA within 2 hours of turbidity exceedance. Implement corrective actions per Section 8.2 of the WQMPP. Resample effluent turbidity while treatment system is in recirculation to confirm effectiveness. With consultation from USEPA, resume treatment system discharge after confirmation that WQ criteria are in compliance and restart Tier 1 Intensive. <u>Concurrent with the above</u> , collect WQ grab samples at Chronic Compliance Stations for TBT analysis as described for TBT Exceedance Action below.	Turbidity Exceedance Action: If confirmed turbidity exceedance in effluent end-of-pipe acute compliance sample , immediately cease discharge of the treatment system. Notify Port PM/USEPA within 2 hours of turbidity exceedance. Analyze the end-of-pipe effluent composite sample with the turbidity exceedance for TBT. Implement corrective actions per Section 8.2 of the WQMPP. Resample effluent turbidity while treatment system is in recirculation to confirm effectiveness. With consultation from USEPA, resume treatment system discharge after confirmation that WQ criteria are in compliance and restart Tier 1 Intensive (Figure B.7). <u>Concurrent with the above</u> , collect WQ grab samples at Chronic Compliance Stations for TBT analysis as described for Tier 1 Intensive Monitoring TBT Exceedance Action below.

Table B.3
Water Quality Monitoring Schedule and Requirements for Dredge Return Water Monitoring

Tier 1—Intensive Monitoring	Tier 2—Routine Monitoring
<p>TBT Exceedance Action:</p> <p>Outcome 2—If TBT in effluent end-of-pipe composite results is less than the acute criterion but greater than chronic criterion, collect WQ grab samples at the Chronic Compliance Stations (150-foot boundary; all three depths) and composite. Then, composite the WQ grabs from both Chronic Compliance Stations each day, for 3 additional consecutive days. Analyze the first day samples collected at Chronic Compliance for TBT and archive the remaining 3 days. Compare the TBT concentration from the first day’s composite to the chronic compliance criterion. If the result exceeds, compare the average TBT result of all composite samples to the 4-day chronic criterion.</p> <ul style="list-style-type: none"> ○ If the average TBT concentration exceeds the chronic criterion, a compliance criterion exceedance has occurred; immediately cease discharge of the treatment system. Notify Port PM and USEPA within 4 hours of exceedance. Implement corrective actions per Section 8.2 of the WQMPP. Resample effluent turbidity while treatment system is in recirculation to confirm effectiveness. Resume treatment system discharge (unless otherwise directed by USEPA) and re-sample chronic compliance boundary TBT by collecting daily samples at two points along the chronic compliance boundary (150 feet from outfall) for 4 days and compare the 4-day average concentration to the TBT chronic criterion. Restart Tier 1 Intensive. ○ If the average TBT concentration is less than the chronic criterion, complete first week of Tier 1 Intensive schedule and proceed with Tier 2 Routine monitoring per WQ schedule. Submit weekly WQ reports. <p>Outcome 3—If TBT in effluent end-of-pipe composite results exceeds the acute criterion, a compliance criterion exceedance has occurred; immediately cease discharge of the treatment system. Notify Port PM and USEPA within 4 hours of exceedance. Implement corrective actions per Section 8.2 of the WQMPP. Resample effluent turbidity and TBT while treatment system is in recirculation to confirm effectiveness. Resume treatment system discharge and restart Tier 1 Intensive monitoring.</p>	<p>TBT Exceedance Action:</p> <p>Not applicable.</p>

Notes:

- 1 pH monitoring will be conducted continuously by sensors located within the dredge return water treatment system, prior to the acute compliance station, and will be adjusted to meet the system performance standard.
- 2 Monitoring of the end-of-pipe Acute Compliance Station is expected to occur through an inline sampling port at the end-of-pipe of the treatment system prior to the point of discharge; therefore, there is no depth associated with this location.

Abbreviations:

- BMP Best Management Practice
- PM Project Manager
- Port Port of Tacoma
- TBT Tributyltin
- USEPA U.S. Environmental Protection Agency
- WQ Water quality
- WQMPP Water Quality Monitoring and Protection Plan

Table B.4
Analytical Requirements, Methods, Preservation, Bottle Type, and Holding Times

Analysis	Method	Bottle Type	Preservative	Holding Time
Tributyltin (Low-Level Dissolved)	Krone	500-mL Polycarbonate Centrifuge Bottle ¹	None, cool to 4 ± 2 °C	7 days to extract, then 40 days to analyze

Note:

1 Polycarbonate bottles were selected to minimize the amount of tributyltin that can adsorb to the sample container, and may be reused after laboratory cleaning. Two bottles should be collected for MS/MSD quality control samples.

Abbreviation:

mL Milliliter

Table B.5
Data Quality Assurance Criteria

Parameter	Precision	Accuracy	Completeness	Reference
Dissolved Tributyltin	± 50% RPD	18–123% R	95%	Krone

Abbreviations:

R Recovery

RPD Relative Percent Difference

**Pier 4 Phase 1 Removal
Action Project**

Removal Action Work Plan

**Appendix B
Water Quality Monitoring and
Protection Plan**

Figures

Note:
Orthoimagery provided by Esri, 2013.



**Removal Action Work Plan
Pier 4 Phase 1 Removal Action Project
Tacoma, Washington**

**Figure B.1
Vicinity Map**



Notes:
 • Pier 4 location based on KPFF data.
 • Background aerial imagery provided by Esri, August 1, 2011.



FLOYD | SNIDER
 strategy • science • engineering

**Removal Action Work Plan
 Pier 4 Phase 1 Removal Action Project
 Tacoma, Washington**

Figure B.2
 Site Location Map of Pier 4

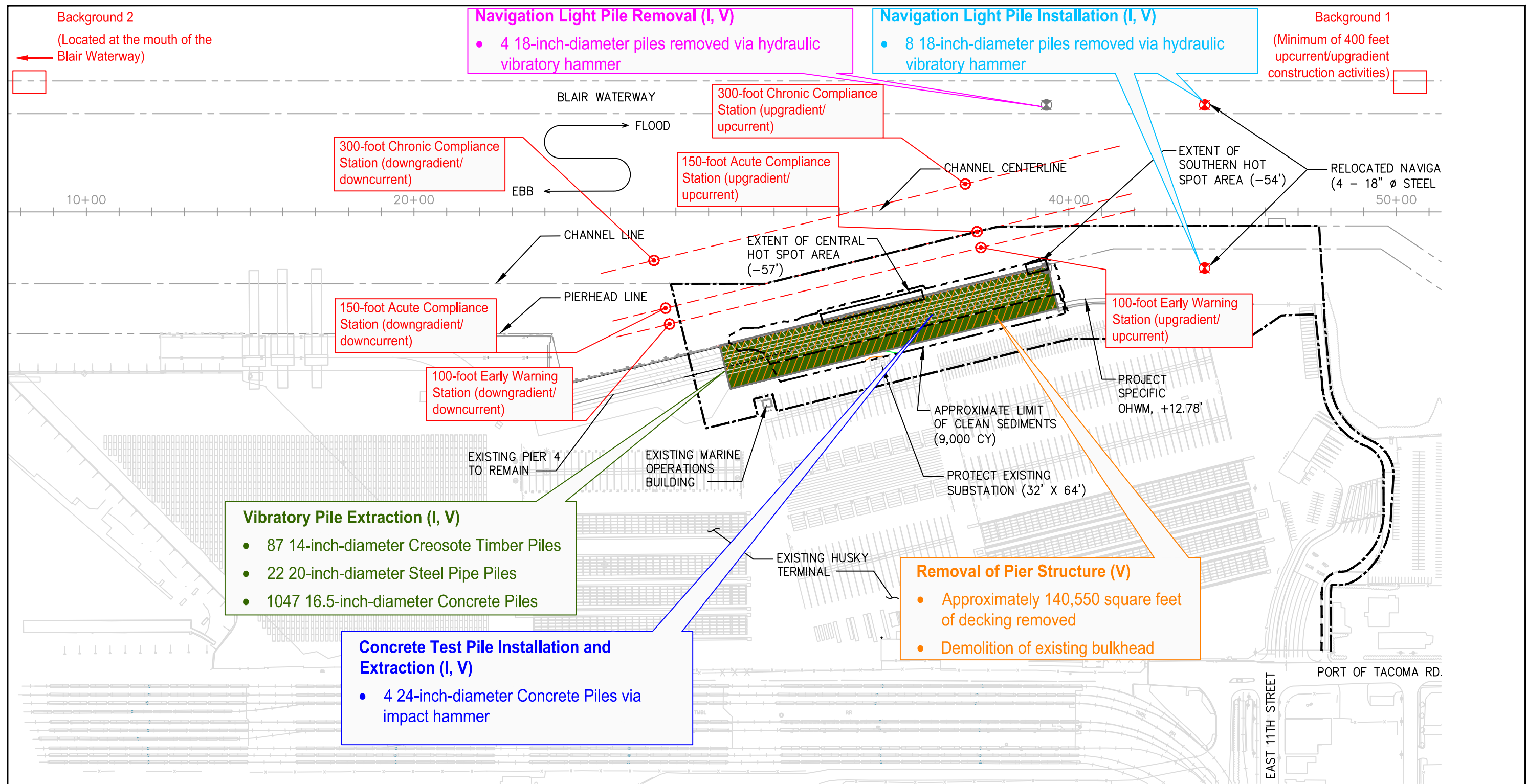

NOTE:
1. MONITORED CONSTRUCTION ACTIVITIES FOR DREDGING SHOWN ON FIGURE B.4.

LEGEND:

- | | | | |
|--|---|--|-----------------------------------|
| | PROJECT WORK LIMITS | | WATER QUALITY MONITORING TYPE |
| | EXISTING PIER 4 DEMOLITION
(140,550 SQ FT) | | INSTRUMENTED TURBIDITY MONITORING |
| | TURBIDITY MONITORING LOCATION (MONITORING LOCATIONS VARY PENDING TIDAL INFLUENCE) | | VISUAL TURBIDITY MONITORING |

OVERALL PLAN

SCALE: 1"=150'

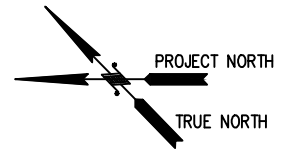
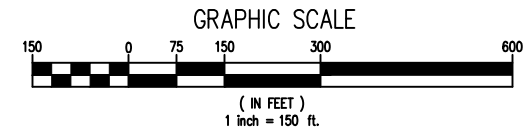

SOURCE: DRAWING PREPARED FROM DESIGN FILES PROVIDED BY KPFF CONSULTING ENGINEERS.

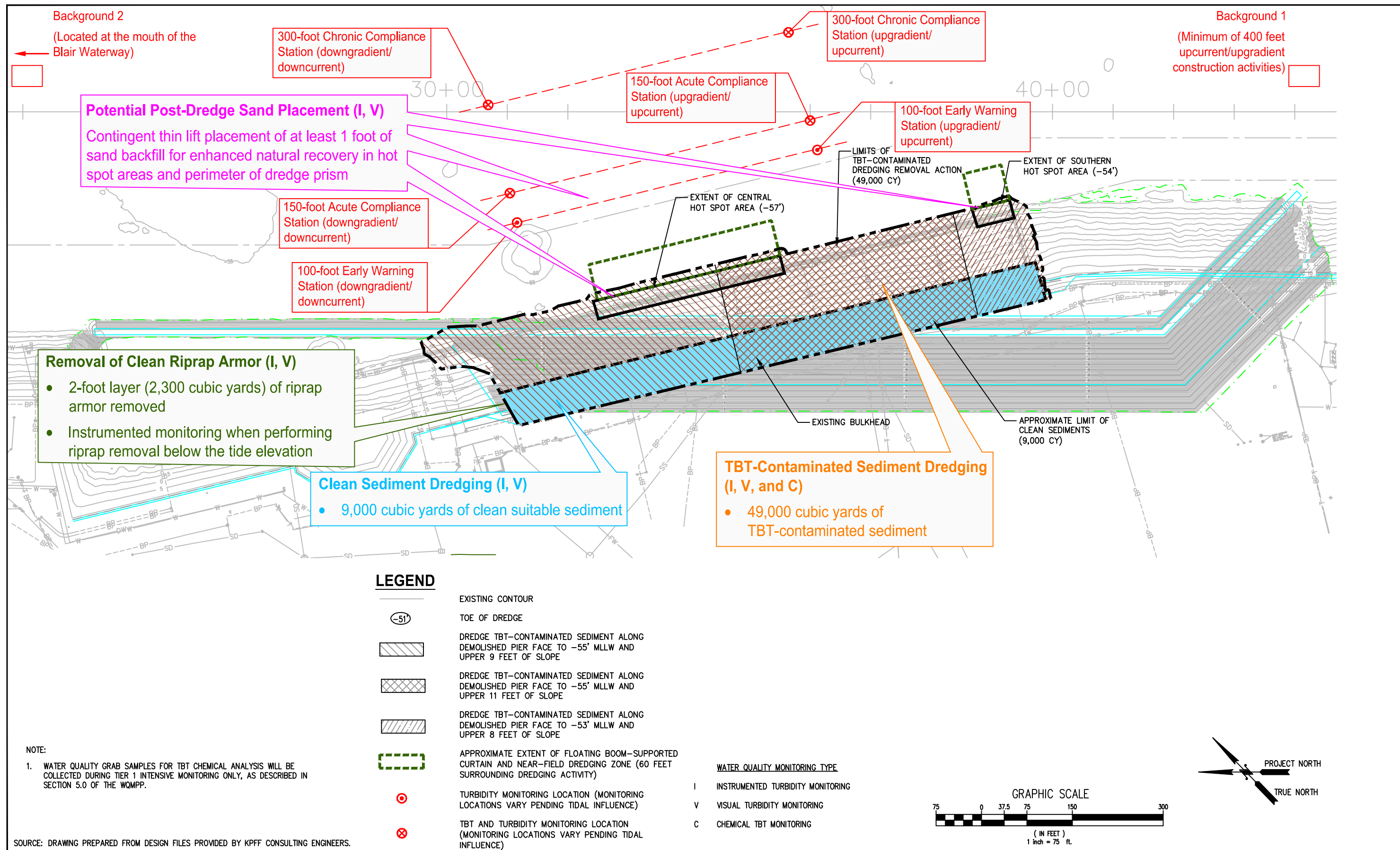

SOURCE: DRAWING PREPARED FROM DESIGN FILES PROVIDED BY KPFF CONSULTING ENGINEERS.

Tier 1—Intensive

Conducted:

- During first 7 days of TBT-contaminated dredging (twice daily)
- During all hot spot dredging (twice daily)

- If turbidity exceedance during Tier 2 Routine monitoring schedule during TBT-contaminated dredging (twice daily)
- Daylight hours

Early Warning Stations
(Two locations at 100-foot boundary)

Acute Compliance Stations
(Two locations at 150-foot boundary)

Chronic Compliance Stations
(Two locations at 300-foot boundary)

Background Stations
(Two locations 400 feet upgradient/up-current and at the mouth of the Blair Waterway)

First 7 Days of Dredging

- Conduct turbidity measurements twice daily at all Early Warning, Acute Compliance, Chronic Compliance, and Background Stations for a total of 48 turbidity measurements per day.
- Measure turbidity at Background Stations first.
- Collect WQ grab samples once daily (during second daily event) at all Compliance and Background Stations for a total of 18 WQ grab samples per day.
- Analyze collected WQ grabs for TBT at the Acute Compliance Station and depth with greatest turbidity measurements on Days 1, 3, and 5 of dredging and archive all other station and depth samples and WQ grab samples collected on Days 2, 4, 6, and 7.



FLOYD | SNIDER
strategy ■ science ■ engineering

Removal Action Work Plan
Pier 4 Phase 1 Removal Action Project
Port of Tacoma
Tacoma, Washington

Figure B.5
Tier 1 Intensive Water Quality Schedule
during TBT-Contaminated Sediment Dredging

Tier 2—Routine

Conducted:

- Twice per day, 2 days per week during pile extraction, pile installation, riprap removal below the tide elevation, dredging of clean sediments, and potential post-dredge sand placement
- Twice per day, 2 days per week during dredging when Tier 1 Intensive monitoring is not required
- Daylight hours

Early Warning Stations
(Two locations at 100-foot boundary)

Acute Compliance Stations
(Two locations at 150-foot boundary)

Chronic Compliance Stations
(Two locations at 300-foot boundary)

Background Stations
(Two locations 400 feet upgradient/up-current and at the mouth of the Blair Waterway)

2 days per week during Dredging, Pile Installation, and Pile Extraction

- Conduct turbidity measurements twice daily at all Early Warning, Acute Compliance, Chronic Compliance, and Background Stations (all depths) for a total of 48 turbidity measurements per monitored day.
- Measure turbidity at Background Stations first.

If No Turbidity Exceedances

- Continue monitoring per WQ schedule for Tier 2 Routine (described above).

If Confirmed Turbidity Exceedance(s) at Compliance Station

If confirmed turbidity exceedance at Acute or Chronic Compliance Stations:

- Notify Port PM and USEPA within 2 hours of exceedance.
- The Contractor will modify operations and implement additional BMPs.
- Continue turbidity monitoring every 2 hours for remainder of day until compliance is demonstrated, or directed otherwise by USEPA.
- If dredging in TBT-contaminated sediments, return to Tier 1 Intensive monitoring per WQ schedule (Figure B.5).

If confirmed turbidity exceedance at both Acute and Chronic Compliance Stations:

- The Contractor will cease operations and modify and/or implement additional BMPs.
- Notify Port PM and USEPA within 2 hours of exceedance.
- Figure B.5 describes the steps to follow if confirmed exceedance at Chronic Compliance Stations.

- Compare turbidity measurements between Compliance and Background Stations to evaluate WQ exceedance.

If Confirmed Early Warning Turbidity Elevation(s)

- Adjust BMPs as needed, then re-measure turbidity at Early Warning Stations.

Note:

Confirmed turbidity exceedance: Following initial exceedance, Background Station monitoring will confirm that the turbidity exceedance at a Compliance Station was not related to background waterway conditions.

Abbreviations:

BMP = Best management practice TBT = Tributyltin WQ = Water quality
 PM = Project Manager USEPA = U.S. Environmental Protection Agency



FLOYD | SNIDER
strategy ▪ science ▪ engineering

Removal Action Work Plan
Pier 4 Phase 1 Removal Action Project
Port of Tacoma
Tacoma, Washington

Figure B.6
Tier 2 Routine Water Quality Schedule
during Pile Extraction, Navigation Light Pile Installation, and Dredging

Tier 1—Intensive

- Conducted:
- Daily during first 7 days following startup of the dredge return water treatment system operation during TBT-contaminated dredging
 - Daily during all hot spot dredging
 - If turbidity or TBT exceedance during Tier 2 Routine monitoring schedule
 - Daylight hours (at Chronic Compliance Station)

Acute Compliance Station
(One location at end-of-pipe of treatment system, prior to outfall discharge to waterway)

Chronic Compliance Stations
(Two locations at 150-foot boundary)

First 7 Days of Dredging

- Collect daily influent and end-of-pipe effluent water quality samples that are composited over 1 hour and measure turbidity in each composite sample.
- Analyze collected composites from the influent and end-of-pipe effluent for TBT on Days 1, 3, and 5 and archive the composite samples collected on Days 2, 4, 6, and 7.
- Compare influent and end-of-pipe effluent turbidity measurements to evaluate the treatment system performance and compare to turbidity WQ criteria.

If No Turbidity Exceedance in Effluent End-of-Pipe Acute Compliance Composite Sample

- Continue monitoring per WQ schedule for Tier 1 Intensive (as described above) and then Tier 2 Routine (as described in Figure B.8)

If Confirmed Turbidity Exceedance in Effluent End-of-Pipe Acute Compliance Sample

- Immediately cease discharge of the treatment system.
- Notify Port PM and USEPA within 2 hours of turbidity exceedance.
- Implement corrective actions per the WQMPP (Section 8.2).
- Resample effluent turbidity while treatment system is in recirculation to confirm effectiveness.
- In consultation with USEPA, resume treatment system discharge after confirmation that WQ criteria are in compliance and restart Tier 1 Intensive.

TBT Chemical Results for Effluent End-of-Pipe Acute Compliance Samples

TBT Outcome #1: TBT composite result does not exceed acute or chronic criterion

• Complete first week of Tier 1 Intensive schedule and proceed with Tier 2 Routine monitoring per WQ schedule.

TBT Outcome #3: TBT in effluent end-of-pipe composite result exceeds acute criterion

- **A compliance criterion exceedance has occurred;** immediately cease discharge of the treatment system.
- Notify Port PM and USEPA within 4 hours of exceedance.
- Implement corrective actions per the WQMPP (Section 8.2).
- Resample effluent turbidity and TBT while treatment system is in recirculation to confirm effectiveness.
- Resume treatment system discharge once compliance with acute criteria is demonstrated and restart Tier 1 Intensive monitoring.

If Confirmed Turbidity Exceedance in Effluent End-of-Pipe Acute Compliance Composite Sample

- After confirmation of the turbidity exceedance, collect WQ grab samples at the Chronic Compliance Stations (150-foot boundary) at all three depths and composite. Composite the WQ grabs at all three depths from both Chronic Compliance Stations each day, for 3 additional consecutive days. Analyze the first day's composite for TBT and archive the remaining 3 days' composites.
- Compare the TBT concentration from the first day's composite to the chronic criterion.
- If exceeds, compare the average TBT result of all composite samples to the 4-day chronic criterion.

TBT Outcome #2: TBT in effluent end-of-pipe composite result less than acute criterion, greater than chronic criterion

- Following receipt of effluent end-of-pipe sample results, collect WQ grab samples at the Chronic Compliance Stations (150-foot boundary) at all three depths and composite. Composite the WQ grabs at all three depths from both Chronic Compliance Stations each day, for 3 additional consecutive days. Analyze the first day's composite for TBT and archive the remaining 3 days' composites.
- Compare the TBT concentration from the first day's composite to the chronic criterion.
- If exceeds, compare the average TBT result of all composite samples to the 4-day chronic criterion.

- **A compliance criterion exceedance has occurred;** immediately cease discharge of the treatment system.
- Notify Port PM and USEPA within 4 hours of exceedance.
- Implement corrective actions per the WQMPP (Section 8.2).
- Resample effluent turbidity while treatment system is in recirculation to confirm effectiveness.
- Resume treatment system discharge (unless otherwise directed by USEPA) and collect daily samples at the Chronic Compliance Stations (150 feet from outfall) for 4 days and compare the 4-day average concentration to the TBT chronic criterion.
- Restart Tier 1 Intensive unless TBT results from subsequent Tier 1 Intensive monitoring days do not exceed the criterion.

Note:
Abbreviations:
PM = Project Manager
TBT = Tributyltin
USEPA = U.S. Environmental Protection Agency
WQ = Water quality
WQMPP = Water Quality Monitoring and Protection Plan

No Exceedance of Chronic Criterion

Exceedance of Chronic Criterion



FLOYD | SNIDER
strategy ■ science ■ engineering

Removal Action Work Plan
Pier 4 Phase 1 Removal Action Project
Port of Tacoma
Tacoma, Washington

Figure B.7
Tier 1 Intensive Water Quality Schedule during Dredge Return Water Monitoring

Tier 2—Routine

Conducted:
• 2 days per week during dredging when Tier 1 Intensive monitoring is not required

Acute Compliance Station
(One location at end-of-pipe of treatment system, prior to outfall discharge to waterway)

2 Days per Week during Dredging

- Twice per week, collect daily influent and end-of-pipe effluent WQ samples that are composited over 1 hour and measure turbidity in each composite sample.
- Conduct turbidity measurements on influent and effluent composite samples daily at Acute Compliance Station (end-of-pipe).
- Compare influent and effluent turbidity measurements to evaluate the treatment system performance.
- A total of two turbidity measurements collected per week.

If No Turbidity Exceedances

- Continue monitoring per WQ schedule for Tier 2 Routine (as described above).

If Confirmed Turbidity Exceedance in Effluent End-of-Pipe Acute Compliance Composite Sample

- Immediately cease discharge of the treatment system.
- Notify Port PM and USEPA within 2 hours of turbidity exceedance.
- Analyze the end-of-pipe effluent composite sample with the turbidity exceedance for TBT.
- Implement corrective actions per the WQMPP (Section 8.2).
- Resample effluent turbidity while treatment system is in recirculation to confirm effectiveness.
- In consultation with USEPA, resume treatment system discharge after confirmation that WQ criteria are in compliance and restart Tier 1 Intensive (Figure B.7).

Note:

Abbreviations:

PM = Project Manager
TBT = Tributyltin

USEPA = U.S. Environmental Protection Agency
WQ = Water quality

WQMPP = Water Quality Monitoring and Protection Plan



FLOYD | SNIDER
strategy ■ science ■ engineering

Removal Action Work Plan
Pier 4 Phase 1 Removal Action Project
Port of Tacoma
Tacoma, Washington

Figure B.8
Tier 2 Routine Water Quality Schedule
during Dredge Return Water Monitoring

**Pier 4 Phase 1 Removal
Action Project**

Removal Action Work Plan

**Appendix B
Water Quality Monitoring and
Protection Plan**

**Attachment B.1
Water Quality Monitoring Form**

Daily Water Quality Summary Report Form

Monitoring personnel: _____ Date: _____

Construction activity during monitoring: _____ Activity start time: _____

Current Field Conditions

Weather: _____ Temperature: _____

Any prior disturbances to water body? (Y/N—Describe): _____

Daily meter calibration performed? (Y/N—Describe): _____

Daily water sampler decontaminated? (Y/N): _____

Monitoring

Monitoring Tier: Tier 1 Intensive Tier 2 Routine

Type of monitoring: Instrumented Visual Chemistry

		Water Quality Monitoring Stations							
		Background 1	Background 2	Early Warning		Acute Compliance		Chronic Compliance	
				Station 1	Station 2	Station 1	Station 2	Station 1	Station 2
Station Location	Northing:								
	Easting:								
Station distance from in-water activity or near-field dredging zone in hot spot dredging (feet)		400 feet minimum upgradient	Mouth of Blair	100 feet upgradient	100 feet downgradient	150 feet upgradient	150 feet downgradient	300 feet upgradient	300 feet downgradient
Station distance (feet) during dredge return water monitoring		Not applicable	Not applicable	Not applicable	Not applicable	End-of Treatment System Pipe	Not applicable	150 feet upgradient outfall pipe	150 feet downgradient outfall pipe
Station monitoring time									

		Water Quality Monitoring Stations							
		Background 1	Background 2	Early Warning		Acute Compliance		Chronic Compliance	
				Station 1	Station 2	Station 1	Station 2	Station 1	Station 2
Station Location	Northing:								
	Easting:								
Tidal status (ebb, flood, or slack tide)									
Turbidity reading (NTU)									
Visible turbidity evident?									
Evidence of noncompliance (e.g., construction debris, sheen, oil, concrete, or dying fish? If yes, describe.									
Water quality grab sample collected? If yes, archived or analyzed?									

Was the turbidity standard exceeded (*no more than 10 NTUs greater than background when background ≤ 50 NTU or no more than 20% greater than background when background > 50 NTUs*)? (Y/N—Describe):

If **yes** to water quality standard exceedances, what corrective action(s) were implemented?

Were the Port and USEPA notified of exceedances and action(s)?

Did turbidity return to background following corrective action(s)?

Were there any unusual conditions or critical activities that could have affected water quality?

Were any photographs taken as supporting documentation? (Y/N—Describe):

**Pier 4 Phase 1 Removal
Action Project**

Removal Action Work Plan

**Appendix C
Aspect Consulting Dewatering
Return Water Treatment Technical
Memorandum**

TECHNICAL MEMORANDUM

Port of Tacoma Pier 4 Phase 1 Removal Action
Project, Project No. 091452 - Dredge Return
Water Treatment Criteria, Evaluation of
Treatment Alternatives, and Dredge Return
Water Quality

Prepared for: Port of Tacoma on behalf of
KPF Consulting Engineers

Project No. 140221-02 • January 20, 2015



e a r t h + w a t e r

TECHNICAL MEMORANDUM

Port of Tacoma Pier 4 Phase 1 Removal
Action Project, Project No. 091452 - Dredge
Return Water Treatment Criteria, Evaluation
of Treatment Alternatives, and Dredge
Return Water Quality

Prepared for: Port of Tacoma on behalf of
KPF Consulting Engineers

Project No. 140221-02 • January 20, 2015

Aspect Consulting, LLC

A handwritten signature in black ink, appearing to read "Tom Atkins".

Alan Noell, PhD, PE
Associate Remediation Engineer
anoell@aspectconsulting.com

Tom Atkins, PE, LG
Sr. Associate Water Resources Engineer
tatkins@aspectconsulting.com

V:\140221 Port of Tacoma Pier 4 Cleanup\Deliverables\Dredge Return Tech Memo\Dredge Return
Water Treatment Tech Memo.docx

Contents

Acronyms	iii
1 Introduction	1
1.1 Background	1
1.2 Treatment System Performance Objectives	2
1.3 Document Organization	2
2 Relevant Site and Predicted Water Quality Information.....	3
3 Dredge Return Water Treatment Alternatives.....	5
3.1 Precedent Dredging and Water Treatment Projects	5
3.1.1 Hylebos Waterway Dredging and Water Management.....	5
3.1.2 Boeing Plant 2 Dredge Return Water Treatment System.....	6
3.1.3 Barge-Mounted Treatment System for TBT-Contaminated Ship Washdown Water	7
3.1.4 Ottawa River Sediment Remediation Dredge Return Water Treatment System	8
3.2 Tributyltin Treatment Technologies.....	9
3.2.1 Municipal Treatment Systems.....	10
3.2.2 Coagulation/Co-Precipitation, Settling, and Filtration Processes.....	10
3.2.3 Granular Activated Carbon	11
3.2.4 Oxidation and UV Irradiation.....	11
3.2.5 Ion Exchange.....	12
3.2.6 Solvent Extraction.....	12
3.2.7 Recommended Tributyltin Treatment Technologies.....	12
4 Recommended Dredge Return Water Treatment Train.....	14
4.1 Primary Screening and Settling	14
4.2 Electrocoagulation and Settling	15
4.3 Filtration.....	16
4.4 GAC	16
5 Recommended Dredge Return Water Treatment Criteria	18
6 Dredge Return Water Quality	21
6.1 Anticipated Dredge Return Water Quality	21
6.2 Responses to Exceedance of Water Quality.....	21

References.....23

Limitations.....25

List of Tables

5-1 Water Quality Criteria for Tributyltin.....19

5-2 Points of Compliance and Water Quality Standards for Dredging Activity at Boeing Plant 2 Early Action Area.....20

5-3 Recommended Water Quality Standards and Points of Compliance for Dredge Return Water for the Phase 1 Removal Action.....21

List of Figures

1 Vicinity Map

2 Recommended Treatment Train Schematic Diagram

3 Marine Water Designated Uses and Criteria

List of Appendices

A Precedent Dredging and Water Treatment Project Reports

Acronyms

AOC	Administrative Settlement Agreement and Order on Consent
BMPs	best management practices
CASRM	Center for Advanced Ship Repair and Maintenance
CERCLA	Comprehensive Environmental Response, Compensation, and Liability Act
DAF	dissolved air flotation
DMMP	Dredge Material Management Program
DRET	Dredge elutriate tests
EPA	U.S. Environmental Protection Agency
GAC	granular activated carbon
gpm	gallons per minute
HDPE	high-density polyethylene
ITRC	Interstate Technology Regulatory Council
MLLW	mean lower low water
NTU	nephelometric turbidity unit
PCB	polychlorinated biphenyl
Port	Port of Tacoma
POTW	publicly owned treatment works
RAWP	Removal Action Work Plan
TBT	tributyltin
TSCA	Toxic Substances Control Act
UV	ultraviolet light
VOC	volatile organic compound
WQMPP	Water Quality Monitoring and Protection Plan
WQC	Water Quality Certification

1 Introduction

This technical memorandum describes the recommended dredge return water treatment criteria, evaluation of treatment alternatives, and anticipated dredge return water quality for the Pier 4 Phase 1 Removal Action Project for the Port of Tacoma (Phase 1 Removal Action). This document is provided as Appendix C to the Pier 4 Phase 1 Removal Action Work Plan (RAWP) and is intended to provide a basis for the dredge return water design specifications. The RAWP and the Water Quality Monitoring and Protection Plan (WQMPP, Appendix B of RAWP) provide details for compliance and monitoring requirements, and supersede references included in this document.

1.1 Background

The Port of Tacoma (Port) Pier 4 Reconfiguration Project involves reconfiguring Piers 3 and 4 along the Blair Waterway to accommodate ultra-large container ships (Figure 1). The planning phase of the Pier 4 Reconfiguration Project included sediment characterization under the Dredged Material Management Program (DMMP), and tributyltin (TBT) concentrations exceeding the DMMP screening level of 73 $\mu\text{g}/\text{kg}$ (EPA, 1996) were identified. No other contaminants of concern were detected at concentrations greater than DMMP screening levels.

The Port has entered into an Administrative Settlement Agreement and Order on Consent (AOC) with EPA to address assessment, dredging, and related activities for the TBT-contaminated sediment, which are being performed as time-critical removal actions under the Comprehensive Environmental Response, Compensation, and Liability Act (CERCLA). The Pier 4 Reconfiguration Project will be completed in two phases, where Phase 1 includes the removal action for the contaminated sediment and Phase 2 involves the completion of the reconfiguration project after the removal action.

An estimated 58,000 cubic yards (in-place) of sediment will be dredged during the Phase 1 Removal Action project. This includes approximately 9,000 cubic yards of non-contaminated sediment from the top of the slope to approximately -2 feet mean lower low water (MLLW) and approximately 49,000 cubic yards of contaminated sediment from -2 feet MLLW to the toe of the slope. Sediment will be mechanically dredged using a modified clamshell bucket, and the dredged sediment will be placed and fully contained on a barge. Dredging will occur from the top of the slope to the toe of the slope. It's anticipated that dredging will be performed with up to three passes of the dredge bucket depending on the area.

The non-contaminated sediment towards the top of the slope will be transported to the DMMP Commencement Bay open water disposal site (per signed Suitability Determination on January 8, 2015). Dredging of TBT-contaminated material will then progress starting at the upper end of the slope and work towards the toe. Two zones of sediment with a relatively high concentration of TBT ("hot spots") exist towards the toe of the slope. Hot spot dredging at the toe of the slope will occur only after the relatively less contaminated material along the upper portion of the slope is removed.

The bucket removes the planned depth of sediment and the overlying water. The percentage of water in the bucket is higher for the final pass of the bucket, as the final pass includes a thinner dredge cut of sediment. The volume of the dredge return water is anticipated to be comparable to the in-place volume of sediment. Dredging is currently scheduled for late summer to early fall, 2015.

The TBT-impacted sediment will need to be dredged, transloaded and ultimately disposed at an appropriately permitted upland disposal facility. Management and treatment of dredge return water will be an important component of these activities. Alternative sites are currently being reviewed for transloading, and transloading best management practices (BMPs) are currently being developed. The uplands transloading site will be at the APM Terminal on the Sitcum Waterway.

1.2 Treatment System Performance Objectives

The dredge return water treatment system performance objectives are listed below:

- Conform with applicable Federal water-quality based, technology-based, and toxic or pre-treatment effluent limitations;
- Conform with state water quality standards;
- Conform with the provision of using all known, available and reasonable methods to prevent and control pollution of state waters; and
- Achieve all performance criteria specified in EPA's 401 Water Quality Memorandum.

1.3 Document Organization

This document is organized into six sections. Section 1 provides an introduction and background information. Relevant site information including water quality information is described in Section 2. Section 3 summarizes precedent dredging and water treatment projects and describes the TBT treatment technologies that were reviewed. Section 4 provides information on the recommended treatment train including pre-treatment, primary treatment, and polishing treatment. Recommended dredge return water treatment criteria are provided in Section 5, and a summary of the anticipated dredge return water quality and corrective actions for water quality exceedances are described in Section 6. Referenced reports are provided in Appendix A.

2 Relevant Site and Predicted Water Quality Information

The dredge return water will consist of both overlying water collected in-conjunction with the sediment dredging and sediment pore water. A summary of site water quality information is provided below (Floyd Snider, 2014):

- TBT was not detected in the July 2014 ambient water sample collected from approximately 6 feet above the TBT sediment hot spot with a reporting limit of 0.005 µg/L.
- Dissolved TBT concentrations ranged from 0.074 to 1.8 µg/L in *in situ* sediment pore water.
- Dredge elutriate tests (DRET) were conducted with TBT-contaminated sediment samples representative of site conditions to gain information regarding potential water quality impacts during the removal of the TBT-contaminated material and to predict TBT concentrations within the active dredge area. The DRET results include the following:
 - Dissolved TBT concentrations (0.16 to 0.39 µg/L) are less than the acute criterion, and total TBT concentrations (0.26 to 0.78 µg/L) are less than two times the acute criterion (0.42 µg/L). All dissolved TBT concentrations exceeded the USEPA chronic marine aquatic life water quality criterion of 0.0074 µg/L.
 - The DRET supernatant results indicate that the TBT is sequestered to the sediment particles—relative to what could be calculated to be in water using literature-based equilibrium partitioning coefficients.
 - TBT concentrations during dredging activities are not expected to exceed the acute water quality criterion in the immediate vicinity of the dredging operation.
- U.S. Army Corps of Engineers DREDGE Modeling was used to assess potential acute water quality effects within the immediate vicinity of the dredging as well as at the compliance boundaries for both acute and chronic criteria. Modeling results indicate the following:
 - TBT concentrations during dredging activities are not expected to exceed the acute or chronic water quality criteria within the immediate vicinity of the dredging or at the compliance boundaries under the “base” model run, which uses proposed applicable input-parameters, or under multiple sensitivity analysis runs with various ranges of key input parameters (modeling results are presented in Appendix F of the Removal Site Evaluation Report (Floyd|Snider 2014).

It is estimated that the sediment barges will contain roughly a 1:1 ratio of sediment and water. Assuming a sediment porosity of approximately 33 percent, on average the recommended dredge return water treatment system (discussed in Section 4) will treat influent roughly containing a 3:1 ratio of overlying water and pore water. The actual ratio at a given time will depend on many factors including whether the sediment barge

contains sediment from a first versus second pass since the percentage of water in the bucket will be higher for the second or third pass of the bucket.

Based on the above water quality information, the influent concentrations of TBT for the dredge return water treatment system are anticipated to be below, and in most cases, well below the dissolved TBT acute criterion (applicable at the end-of-pipe) of 0.42 µg/L (see Section 5 for detailed discussion on criterion). The influent to the dredge return water treatment system is anticipated to be well below the TBT acute criterion during the initial couple of weeks of treatment, when dredging of relatively less-contaminated sediments along the upper portion of the slope will occur. It is anticipated that the dredge return water treatment system will receive influent from hot spot dredging a couple weeks after the start of treatment.

3 Dredge Return Water Treatment Alternatives

This section describes precedent dredging and water treatment projects and identifies and reviews alternative TBT treatment technologies. The dredge return water treatment system will need to treat both water pumped from barges and water drained from on-shore sediment dewatering. Effluent from the treatment system will need to consistently meet the discharge criteria described in Section 5.

The location of the dredge return water treatment system is anticipated to be adjacent to the upland sediment dewatering area; however, a small treatment system could potentially be placed on a mobile barge. The overall treatment system should have the necessary storage and redundancy such that water treatment does not restrict the dredging schedule. Storage is necessary to accommodate relatively high dewatering rates from sediment barges and to equilibrate the treatment flow rate. Storage may also be necessary to recycle treated water within the system as necessary, and possibly to store water when components are taken offline for servicing. The treatment system should be capable of operating when filter media is backwashed or when accumulated sediment or sludge is removed from tanks.

3.1 Precedent Dredging and Water Treatment Projects

Precedent dredging and water treatment project information is summarized below. Referenced reports that were available are provided in Appendix A.

3.1.1 *Hylebos Waterway Dredging and Water Management*

Fuglevand and Webb (2006) described the mechanical dredging and water management for the dredging of 65,000 cubic yards of polychlorinated biphenyl (PCB) and metals-contaminated sediment from the headwaters of the Hylebos Waterway in 2005 and 2006, which is part of the Commencement Bay/Nearshore Tidelands Superfund site in Tacoma. The majority of the dredging was performed using an articulated arm dredge with a 3-cubic-yard, closed-hydraulic-clamshell dredge bucket. The closed dredge bucket picked up sediment and water and the material was placed on flat-deck barges with 4-foot high, water-tight sidewalls that held 250 cubic yards of material. Turbid water was pumped from the barges during dredging operations using a submerged centrifugal pump that was deployed from a 20-ton crane that was loaded on a small work barge. The water was pumped through a 4-inch-diameter high-density polyethylene (HDPE) floating line to the upland sediment capture system.

The upland sediment capture system included the following components:

- Water was pumped to a settling chamber to separate sand-sized and larger particles, and overflow from the settling chamber was pumped to four 18,000-gallon holding tanks;
- A grab sample of turbid water was collected from the holding tanks and was tested with polymer (Nalco No. 7768) to determine the proper dosing, then the required amount of polymer was added to each batch and gently mixed for a few minutes to flocculate particles;

- The water and flocculated particles were pumped to three geotextile tubes (100-foot long with 60-foot circumference) for solids removal; and
- Filtered water from the geotextile tubes was pumped to a holding lagoon, and then pumped through sand filters and bag filters prior to discharge back into the waterway.

The dredged material was removed from the barges using a hydraulic excavator on the dock equipped with a Young hydraulic clamshell bucket and placed in containers on railcars adjacent to the dock. The contaminated sediment was then transported by railcar to the Roosevelt Regional Landfill in Roosevelt, Washington for disposal.

Fuglevand and Webb (2006) provide water volume estimates that may be replicated for the dredging of TBT-contaminated sediment for the Phase 1 Removal Action. For environmental dredging, the enclosed bucket is filled with sediment and water, and the ratio of sediment and water in the bucket is dependent of the thickness of the cut, the bucket size and type, the material type, and the operator skills. For the 2005/2006 environmental dredging project, the in-place volume of contaminated sediment was 65,000 cubic yards. A total of 75,000 cubic yards of water was pumped from the barges and treated. The geotextile tubes used for solids removal captured 4,000 cubic yards of material. Additionally, an estimated 10,000 cubic yards of entrained water (15 percent) was disposed with the contaminated sediment.

3.1.2 Boeing Plant 2 Dredge Return Water Treatment System

The Lower Duwamish Waterway Superfund Site provides precedents for the management of dredge return water on a CERCLA site. Dredge return water management practices were reviewed for environmental dredging of PCB-contaminated sediment at several projects including the Slip 4, Terminal 117, Boeing Plant 2, and Jorgensen Forge early action areas. The Boeing Plant 2 Early Action Area appears to provide the most recent precedent for dredge return water management and is summarized below.

The Boeing Plant 2 dredging project includes the dredging of 260,000 cubic yards of PCB-contaminated sediment from the Lower Duwamish Waterway during three construction seasons. Boeing Plant 2 dredging is being performed during approved fish windows between August 1 and February 15. Dredging was initiated during January 2013 and is scheduled to be completed by 2015.

During the first construction season in 2013, 36,000 cubic yards of non-Toxic Substance Control Act (TSCA)-regulated, PCB-contaminated sediment was mechanically dredged using a 4-cubic-yard Young dredging bucket with three passes. The precision dredging bucket captured approximate equal quantities of sediment and water, which were placed on a sediment barge. AMEC (2013) reported that the volume of dredge return water approximately equaled the volume of sediment. The volume of sediment was 7.3 million gallons and 6.1 million gallons of treated dredge return water was discharged to the Lower Duwamish Waterway; however, 8.1 million gallons of dredge return water were treated because of recirculation. Although the anticipated dredging rate was 900 to 1,800 cubic yards per day, the actual dredging rate was 900 cubic yards per day based on an estimated 40 days of dredging. The excess water was actively pumped from the sediment barge to a shore-based dredge return water treatment system, and the ponded water on the sediment barge was not released to the Lower Duwamish Waterway.

The sediment barges were transported to the Lafarge Cement Plant on the Lower Duwamish Waterway and the sediment was off-loaded to a 5,600 cubic yard concrete containment vault and stabilized with cement kiln dust, and later Portland cement and fly ash, prior to off-site disposal. Stormwater from the loading area was segregated from the rest of the facility and pre-treated prior to discharge to the sanitary sewer. The stormwater treatment system consisted of a series of holding tanks, sand filters, bag filters, and granular activated carbon (GAC).

The water on the sediment barges was pumped to the shore-based dredge return water treatment system designed to treat 300 gpm of water. The dredge return water treatment system included (AMEC, 2013):

- Surge tanks to receive 1,200 gpm influent water and to equilibrate flow;
- Tri-Flow International shaker screen system to remove debris, gravel, and sand greater than 100 microns in size;
- Pre-treatment, closed-top settling tanks that provided water storage and allowed fines to settle in the tanks;
- Electrocoagulation treatment units to flocculate the fines and initiate settling of the particles;
- Post-treatment settling tanks where the flocculated particles settled out;
- Sand filter to remove turbidity;
- Two bags filters in series with 1 micron filters to protect the GAC filters; and
- Two GAC filters in series to remove dissolved organic particles and PCBs.

A very limited site footprint was available for the dredge return water treatment system during the first construction season. One of the primary challenges that occurred during the first season was the very high solids content of the water that was pumped off of the barge (up to 37,000 mg/L total suspended solids). This resulted in excessive sludge buildup in the closed-top tanks, which was very difficult to clean due to confined space concerns (Liisa Doty, 2014). This challenge was remedied during the second construction season in 2014 by designing a lined ecology block pond for settling (prior to electrocoagulation) and adding a post-coagulation clarifier with a v-bottom to facilitate sludge removal (Liisa Doty, 2014).

3.1.3 Barge-Mounted Treatment System for TBT-Contaminated Ship Washdown Water

Fox et al. (1999) described a barge-mounted experimental treatment system used for removing TBT in ship washdown in Norfolk, Virginia. TBT-contaminated washwater was generated when the underwater portions of the hull were spray washed in dry dock to remove sea salt, wet marine slime, and the top layer of antifouling paint. The washwater was collected in troughs on the apron of the dock and pumped into holding tanks prior to treatment. The amount of washwater depended on the size of the hull; however, a typical application generated about 140,000 gallons of washwater with TBT concentrations ranging from 10 to 500 µg/L. The treatment system included:

- Dissolved Air Flotation (DAF) to remove suspended solids, including adsorbed TBT;
- Sand filters to remove fine suspended particles;
- Two serial GAC canisters to remove dissolved TBT; and
- Discharge of treated effluent to surface water.

The system was designed to recycle washwater through each process depending on sampling results. Fox et al. (1999) remarked that TBT analysis at levels of parts per trillion was complicated and labor intensive, and that laboratories that routinely perform TBT analysis required a minimum of 2 days for TBT analysis.

The experimental treatment system was not properly scaled. For example, the DAF was rated for 25 gpm, but operated at rates up to 60 gpm. The DAF was also optimized for the removal of zinc and copper, and not the removal of TBT. The GAC bed was also undersized for the flow rate. In the next phase of their research program, the authors recommended a recycle-type DAF system with a 100-gpm capacity, a mixed media filter, and two high-pressure GAC containers scaled for a minimum of 25 minutes of contact time at full flow.

3.1.4 Ottawa River Sediment Remediation Dredge Return Water Treatment System

EPA Region 5 and several stakeholders are addressing PCB-contaminated sediment in the Ottawa River under the Great Lakes Legacy Act of 2002. The Ottawa River Sediment Remediation Project, performed in Toledo, Ohio 2010, involved hydraulic dredging of 242,000 cubic yards of PCB-contaminated sediment (Cretens, 2011). The hydraulically dredged sediment was transported through a pipeline to the nearby Hoffman Road Landfill. Cationic emulsion polymer was mixed with the hydraulically dredged sediment prior to dewatering. Two separate polymer make down systems were used, which diluted the 35 to 40% neat solution to 1% solution, and each system had a capacity of treating 200 gpm hydraulically dredged sediment. The 226,000 cubic yards of non-TSCA regulated sediment were pumped to sediment thickeners, which had a shaker screen system to remove debris and coarse-grained material, hoppers for sludge thickening, and overflow for water effluent. The sludge from the hoppers was treated with a second dose of polymer and pumped to geotextile tubes for dewatering and disposal.

Water effluent flowed to the water treatment system. After the initial injection of polymer, the 16,000 cubic yards of TSCA-regulated sediment was pumped directly to geotextile tubes for dewatering, without screening and sludge thickening, and the dewatered sediment in the geotextile tubes was transported to a TSCA-licensed landfill. The dredge return water from the sludge thickeners and the filtered water from the geotextile tubes were pumped to the water treatment system, which was designed to treat 3,000 gpm of influent.

As described below, the water treatment system used flocculation, coagulation, and settling to remove suspended particles; two-step filtration to remove colloidal solids; and GAC to remove dissolved organics and PCBs:

- Influent water was dosed with ferric chloride chemical coagulant and the flocculated particles were removed in seven parallel lamella clarifiers. The effluent from the lamella clarifiers was routed to four 21,000-gallon holding tanks to equilibrate the flow.
- Water was pumped from the holding tanks to five parallel-pressurized multi-media filters. The filter beds included three sizes of filter gravel, filter sand, and anthracite coal. The pressure drop was measured across the filters, and the system was designed so that one multi-media filter could be backwashed while the other two operated. The backwash was equipped with a hydrogen peroxide feed to remove sticky buildup in the media. The effluent from the multi-media filters flowed through a common pipe and then through three parallel bag filters. Bag filters were used to prevent fouling of the GAC.
- A total of 10 GAC vessels were arranged in five pairs of lead-lag units. Each vessel was loaded with 20,000 pounds of GAC and was capable of treating 1,000 gpm of water. The effluent from the GAC vessels was closely monitored for turbidity and pH before discharge to the river. The differential pressure across the GAC vessels was monitored to determine when backwash was necessary. Three 21,000-gallon tanks were filled with GAC-treated water and used for backwashing of multi-media filters and GAC, dilution of polymers prior to geotextile tubes, and as mechanical seal water for the last dredge booster pump station.
- The lamella clarifier sludge and the backwash water from the multi-media filters and GAC vessels were transferred to a waste tank and then pumped to a geotextile tube for dewatering.

3.2 Tributyltin Treatment Technologies

TBT is a non-volatile compound that is typically associated with particulates, and applicable TBT treatment technologies generally have included solids separation, sorption of organics, and oxidation. TBT can also be biodegraded to di-butyltin, mono-butyltin, and inorganic tin, which have lower toxicity than TBT.

The Center for Advanced Ship Repair and Maintenance (CASRM)--a partnership between private ship repair yards of Hampton Roads, Old Dominion University, and the City of Norfolk, Virginia--has evaluated numerous treatment technologies for TBT in industrial wastewaters, including coagulation, clarification, filtration, GAC adsorption, ultraviolet (UV) irradiation, membranes, and ozonation. The CASRM website (<http://eng.odu.edu/casrm>) provides several wastewater technology review papers from 1997 to 2003. Champ et al. (1999) also includes summaries of TBT technologies, including UV oxidation; DAF, sand filtration, and GAC sorption; and a solvent extraction process. In addition, TBT CLEAN (2003) provides a review of TBT treatment technologies for sludge and wastewater, including photo-oxidation processes, activated sludge, GAC, and solvent extraction. TBT treatment technologies are summarized below, and referenced reports that were available are provided in Appendix A.

3.2.1 Municipal Treatment Systems

Pre-treated dredge water could be discharged to the publicly owned treatment works (POTW) for TBT removal. Messing et al. (1997) reports the POTWs have removed about 90% of TBT after secondary sedimentation treatment and aerobic treatment, and additional filtration has removed 98% of TBT. Scrimshaw et al. (2013) examined the fate and behavior of TBT at two POTWs. The TBT removal rate was 68% in the POTW with tertiary treatment processes for ammonia and solids removal, and most of the TBT removal was due to solids removal during the primary settling. The TBT removal rate was 95% in the POTW that used conventional trickling filters for secondary treatment, with 94% of the removal due to biodegradation in the trickling filter. Scrimshaw et al. (2013) concluded that differences in the solubility of TBT may have resulted in the different removal rates, but indicated that the biological processes may be capable of TBT removal in POTWs. TBT adsorption to sewage sludge may be significant, and could impact the use and disposal of the sludge. For shipyard effluents, which may contain 50 to 50,000 µg/L of TBT, Messing et al. (1997) and Fletcher and Lewis (1999) report these concentrations may be sufficiently toxic to suppress all microbial activity in activated sewage sludge.

POTW discharge of TBT-contaminated wastewater would not be allowable without pre-treatment. Pre-treatment would likely include the settling and filtration of fines. Since settling is also the primary TBT removal process in the POTW, the POTW may have limited capability of treating the residual TBT after pre-treatment. Saltwater also adversely impacts the biological population and may preclude the discharge of the dredge return water through the POTW.

3.2.2 Coagulation/Co-Precipitation, Settling, and Filtration Processes

Coagulation and co-precipitation rely on physical and chemical processes to coagulate fine solids, or precipitate and settle target contaminants. These technologies can be particularly effective in removal of colloidal or non-settleable solids. Coagulation/co-precipitation systems can be fully automated and can contain internal system monitoring for a variety of parameters including turbidity and pH, with automatic control adjustments performed as needed. Primary coagulation and co-precipitation treatment processes are typically followed by separation process and filtration. Separation processes can include use of settling tanks, hoppers, lamella clarifiers, and/or dissolved air flotation. Filtration can incorporate a variety of filter types such as sand, mixed-media, and/or filter bags for additional removal of solids.

Most coagulation processes involve the use of chemicals such as chitosan, ferric chloride and/or various polymers that are added with controlled dosing rates that can be adjusted for variable influent water quality as measured by turbidity. The application of coagulants requires on-site chemical management, assessment of dosage requirements, and the preparation and metering of the coagulants into the wastewater stream. Additional effluent monitoring may be required, potentially including sampling of residuals and performing bioassay tests to evaluate toxicity of the residuals.

Electrocoagulation does not involve the use of chemicals since the coagulation reaction is generated by passing electrical current across sacrificial steel or aluminum electrodes. In

addition to coagulating solids and precipitating metals, the process can electrochemically oxidize metals and organics. TBT contaminated sediment has been treated electrochemically to detoxify TBT (Stichnothe et al., 2001). Passing a current through saltwater creates very reactive radicals at the cathode and anode, which are able to detoxify TBT. Stichnothe et al. (2001) report that oxidation and reduction reactions are thermodynamically favorable, where TBT degrades to tin oxide (SnO_2) by the oxidation reaction or to tin chloride (SnCl_2) by the reduction reaction.

3.2.3 Granular Activated Carbon

GAC is a specialized type of media filtration that is often used for removing dissolved organics including PCBs. Activated carbon is a form of carbon processed to have small, low-volume pores that increase the surface area available for adsorption or chemical reactions. When GAC is used for organics polishing it must be protected against clogging through effective primary treatment. GAC has a high affinity for TBT; however, since GAC is non-selective, the water must be pre-treated to remove particulates and maximize treatment effectiveness. TBT CLEAN (2003) reports the GAC removal efficiencies can be achieved up to 99.99% under the right conditions. The effectiveness of GAC is a dependent on the contact time, competing sorption reactions, the pH, and the amount of bed volumes. Sand filtration is recommended prior to GAC to remove turbidity and dissolved organic carbon.

Fox et al. (1999) describe CASRM's barge-mounted treatment system used to remove TBT from ship washdown water in Norfolk, Virginia. The process included the addition of caustic and coagulant, dissolved air flotation for removal of solids, sand filtration for removal of fines, and two serial GAC pressure vessels for removal of dissolved organics and TBT. The GAC vessels were designed for a 25-minute contact time at a 100-gpm flow rate. Although the treatment system components were not built at compatible scales, the system was successful in decreasing the concentrations of TBT from 8.3 to 480 $\mu\text{g/L}$ in the influent to less than 0.05 $\mu\text{g/L}$ in the effluent. Fox et al. (1999) emphasize GAC is very effective for TBT removal, but that pre-treatment is critical for improving the effectiveness and longevity of the GAC.

The sorption of TBT to GAC appears to increase with pH (Schafran, 2003; Ayanda et al., 2013). Schafran (2003) conducted column studies to assess breakthrough of TBT in synthetic water (deionized water with a sodium bicarbonate buffer), and evaluated the release of adsorbed TBT with increasing bed volumes and changing conditions. Schafran (2003) reported that the biological reactions occur in the GAC column and increased concentrations of di-butyltin and mono-butyltin were detected near the effluent of the columns.

Ayanda et al. (2013) performed bench scale isotherm studies to assess the effectiveness of GAC, fly ash, and a mixture of GAC and fly ash for TBT sorption in marine water. They found that GAC was much more effective than fly ash alone, but that the mixture of GAC and fly ash had a slightly higher affinity for TBT than GAC alone.

3.2.4 Oxidation and UV Irradiation

Fletcher and Lewis (1999) report that TBT can be oxidized to di-butyltin, mono-butyltin, and inorganic tin by photocatalysis (visible light) and UV irradiation using precursor

oxidation methods that produce hydroxyl radicals, including hydrogen peroxide, ozone, electrolytic oxidation, and Fenton's reagent. These sequential oxidation reactions are first-order reactions that can be expressed in half-lives, and de-alkylated daughter products have lower toxicity than the parent products. Fletcher and Lewis (1999) performed batch test using photocatalysis and oxidation/UV. Although photocatalysis shows the ability to oxidize the TBT, they reported that oxidation/UV half-lives were more than an order of magnitude less and that oxidation/UV was easier to scale up to treat shipyard wash water. When tested independently, neither UV light nor hydrogen peroxide effectively oxidized TBT. The best results were found by adding hydrogen peroxide prior to UV irradiation to create hydroxyl radicals. Fletcher and Lewis (1999) indicated that oxidation using an ozone generator would be more practical than adding hydrogen peroxide. They reported that the effectiveness of photocatalysis and oxidation/UV decreased with turbidity and increased with pH. Platz et al. (1999) performed pilot- and industrial-scale experiments using a treatment train of precipitation/flocculation, sand filtration, ion exchange for copper and zinc removal, and hydrogen peroxide dosing and UV irradiation for TBT treatment. This treatment system removed 99.9% of the TBT.

3.2.5 Ion Exchange

Messing et al. (1997) suggested that non-ionic polymeric ion exchange resins may be used for the TBT removal. The preferred products include AMBERLIGHT® XAD, Duolite®, and Dialon®. Although these resins may be capable of removing organics to less than 1 µg/L, no experimental results have been identified for TBT removal. The influent water for the ion exchange resins should be treated for the removal of solids, turbidity, and organics to increase the effectiveness and longevity of the resin. The resins are normally placed in pressure vessels and 2 to 10 minutes of contact time are needed for treatment. The recovered organics and TBT are recovered from the resins by flushing them with solvents, such as methanol, acetone, dichloromethane, chloroform, diethyl ether, and ethyl acetate.

3.2.6 Solvent Extraction

Ashcroft and Abel (1999) describe a solvent extraction process for TBT removal from ship wash down water. After removal of solids, solvent is dispersed with a high surface area across the process water to enable the transfer of TBT from the process water to the solvent. The required solvent volume is about 2 to 4 percent of the process water, and a wide range of oils is suitable as extraction solvent. After sufficient mass transfer, the process water and extraction solvent are separated and the solvent is then treated or disposed separately. Ashcroft and Abel (1999) report that this process has decreased the concentration of TBT from 2,000 µg/L to less than 0.2 µg/L in process water.

This solvent extraction process is not suitable for the treatment of the dredge return water because of the amount of solvent required to treat the large volumes of dredge return water. A separate solvent treatment process would be needed to economize the process so that solvent could be re-used to minimize the chemical purchase and disposal costs.

3.2.7 Recommended Tributyltin Treatment Technologies

GAC is the recommended treatment technology for removal of dissolved TBT. However, the removal of dissolved TBT will require a treatment train where several precursor

processes are applied before GAC is used as a final polishing step. Since TBT is typically associated with solids, these precursor removal processes would be anticipated to remove a substantial percentage of the influent concentration of total TBT. The recommended treatment train concept includes primary screening and settling, coagulation and settling, filtration, and GAC. Electrocoagulation is the recommended coagulation process because it provides incidental electrolytic treatment and does not require the addition of chemical amendments, which will avoid triggering other potential permitting requirements. The recommended treatment train is further described in Section 4.

Treatment technologies that were not further considered are summarized below:

- Discharge to a municipal treatment system was not retained for further consideration because:
 - Pre-treatment would be required to remove larger solids;
 - TBT removed with remaining solids would be transferred to the sludge;
 - Marine water could negatively impact microbial treatment processes; and
 - A TBT treatment standard would presumably apply prior to discharge to sanitary sewer, which could require use of GAC.
- Oxidation and UV irradiation were not retained for further consideration because:
 - Large volumes of chemicals such as hydrogen peroxide would be required;
 - Longer treatment times would be required; and
 - This treatment process does not have sufficient precedent and would need to be field pilot tested for verification.
- Ion exchange was not retained for further consideration because:
 - Treatment costs would be relatively high compared with GAC; and
 - This treatment process does not have sufficient precedent and would need to be field pilot tested for verification.
- Solvent extraction was not retained for further consideration because:
 - Large volumes of chemical solvents would be required;
 - Disposal of spent solvents would be problematic; and
 - Scaling problems are anticipated.

4 Recommended Dredge Return Water Treatment Train

The sediment barges are anticipated to contain an approximate 1:1 ratio of sediment and water, such that approximately 10 to 12 million gallons of dredge return water will need to be treated. Approximately 150,000 to 300,000 gallons per day of dredge return water will need to be treated, as well as additional stormwater collected at the transload site. The quantity of stormwater requiring treatment is dependent on the season, the intensity and duration of precipitation, available storage, and the control of stormwater run-on onto the approximate 7-acre transload site. The treatment system will need to have a minimum capacity of 600-gpm to treat this water. Note that this scale system would need to operate 8.3 hours per day to treat the anticipated volume of dredge return water, and would have excess capacity to treat stormwater and reject water, and catch up for treatment system downtime. As previously described, the removal of dissolved TBT will require a treatment train where several precursor processes are applied before GAC is used as a final polishing step. The pre-cursor processes should effectively remove dissolved solids, turbidity, and dissolved organic carbon to improve the effectiveness and longevity of the GAC for dissolved TBT treatment.

The recommended dredge return water treatment train concept includes:

- Primary screening and settling to remove larger particles;
- Electrocoagulation and settling;
- Mixed-media filtration to remove TSS, turbidity, and adsorbed TBT; and
- GAC to remove dissolved TBT.

A schematic diagram of the recommended treatment train is provided in Figure 2, and the various components of the treatment train are described below.

4.1 Primary Screening and Settling

The dredge return water will contain a high concentration of solids that will need to be managed and removed to help prevent excessive clogging and solids accumulation later in the treatment system. In addition, since the pumping rate from the barges will probably exceed the treatment system design rate, water storage and flow equalization will be required. Decanting from the dredge barge will need to incorporate a weir or protected pump point to reduce upfront solids loading.

During the first year of dredging at Boeing Plant 2, closed-top 18,000-gallon storage tanks were used for surge capacity, settling, and flow equalization. Prior to settling, a Tri-Flow International dredged slurry separation system was applied to mechanically remove solids from the dredge return water (AMEC, 2013). The dredged slurry separation system was composed of a series of shaker screens that mechanically separate solids from a continuous stream of water using increasingly finer screen sizes. Mobile units can treat water at flow rates up to 2,000 gpm and remove particles down to 25 microns without chemical amendments. The dredged slurry separation system performs well when the solids concentration is 15% by weight. The Boeing Plant 2 system was designed to treat about 350 gpm and remove particles down to 100 microns. The solids were continuously

discharged from the shaker screens to the side of the mobile unit, where they were managed separately. Shaker screens were also installed in the sediment thickener system for the Ottawa River project to remove debris and coarse-grain material prior to sediment thickening and discharge to the geotextile tubes for dewatering (Cretens, 2011).

One of the primary challenges that occurred during the first season of dredging at Boeing Plant 2 was the very high solids content of the water that was pumped off of the barge (up to 37,000 mg/L total suspended solids). This resulted in excessive sludge buildup in the closed-top tanks, which was very difficult to clean due to confined space concerns (Liisa Doty, 2014). This challenge was remedied during the second construction season in 2014 by using a lined ecology block pond for settling prior to electrocoagulation. This lined pond had a capacity of approximately 1.5-million gallons and allowed ample gravitational settling of the dredge return water prior to treatment. The challenge of sludge buildup could also be addressed using tanks with sludge hoppers that are designed for solids extraction or with open top tanks in parallel configuration that can be easily taken offline and cleaned. Many water treatment equipment vendors can provide equipment for primary settling and screening.

4.2 Electrocoagulation and Settling

As described in Section 3.2.2, electrocoagulation systems are used to remove suspended solids and heavy metals from wastewater. Heavy metals, organics, and inorganics are primarily held in water by electrical charges. Electrocoagulation is performed by applying an electrical current across metal plates that are submerged in water. This causes several reactions, including metal dilution at the anode, hydrolysis of water to hydrogen gas and hydroxyl groups at the cathode, and electron flow from the cathode to the anode, which destabilizes the surface charges of the suspended solids. Metal ions complex with the hydroxyl groups, forming flocs of metals and other contaminants.

Electrocoagulation is most effective for neutral pH wastewater, and can increase the pH of the effluent due to the formation of hydroxyl ions at the cathode. A slightly increased pH would increase the effectiveness of GAC for removing dissolved TBT, however, effluent discharge will need to comply with the pH criteria listed in Section 5.

One of the main advantages of electrocoagulation is that no additional coagulants or mix tanks are needed, and the volume of sludge is relatively low compared to other coagulation methods. Electrocoagulation should also provide incidental treatment of TBT by oxidation and reduction reactions at the anode and cathode, which reduce the toxicity of the organotin.

Lamella clarifiers and/or dissolved air flotation can also be used post-coagulation to remove suspended solids prior to filtration. In the WaterTectonics' electrocoagulation system, air is injected through diffusers at the bottom of the tank to sorb to and float the flocculated particles, and incline plates are placed at the bottom of the tank to promote settling to hoppers at the bottom of the tank. The flocculate at the top of the tank is skimmed with rakes to remove the flocculated particles and sludge in the hoppers is discharged to remove the particles.

The dredge return water treatment system at the Boeing Plant 2 Site used two 300 gpm WaterTectonics' Wave Ionic EC systems to remove suspended solids (WaterTectonics, 2014). WaterTectonics has containerized systems that can process 100 to 1,000 gpm of wastewater, and other water quality treatment equipment vendors can also provide electrocoagulation systems.

4.3 Filtration

Filtration is necessary prior to GAC treatment for several reasons. Filtration removes fine particles from the waste stream, which reduces permeability loss in the GAC and decreases the need to backwash the GAC. The filtration system also reduces the upsets from the precursor flocculation and settling process. Ideally, the filtration system reduces the turbidity and the dissolved organic matter in the water, which increases the effectiveness of GAC for dissolved TBT removal.

Granular filters are recommended after the coagulation and settling process and prior to the GAC treatment process. Slow sand filters are effective for the removal dissolved organics and turbidity, but require longer residence times and more frequent backwashing because of pressure loss. Mixed media filters may reduce the pressure losses and provide additional organics removal. At the Ottawa River dredging project (Cretens, 2011), the mixed media filters included gravel, sand, and anthracite, with the gravel and sand capturing larger particles while the anthracite sorbed organic matter.

Granular filters need to be backwashed to remove the captured particles and to increase their permeability. The treatment system should be designed with two or more parallel granular filters, and the granular filters should be designed to operate when one of the filters is offline due to backwashing. The filters should be backwashed with water that has already passed through the filter and the backwash water should be recirculated through the coagulation/flocculation process.

Bag filters can be used as a final polishing step to prevent fouling of the GAC. Two serial bag filters with 1 micron filters were used between the sand filters and the GAC at the Boeing Plant 2 dredge return water treatment system (AMEC, 2013) and three parallel bag filters were used before the multi-media filters and GAC for the Ottawa River dredge return water treatment system (Cretens, 2011). Many water treatment equipment vendors can provide filtration systems.

4.4 GAC

Activated carbon, also called activated charcoal, is a form of carbon processed with oxygen to create millions of tiny pores between the carbon atoms, which increases the surface area available for adsorption or chemical reactions. One pound of activated carbon (a quart container) can have the surface area equivalent of six football fields. Adsorption is a process by which impurities in fluids are held within the carbon's internal pore structure by electrostatic attraction or chemisorption, and removed from the fluid. Water contaminants adsorb because the attraction of the carbon surface for them is stronger than the attractive forces that keep them dissolved in solution.

The primary raw material used for activated carbon is an organic material with a high carbon content such as coal. The carbon-based material is converted to activated carbon

by thermal decomposition in a furnace using a controlled atmosphere and heat. GAC media is most commonly produced by grinding the material, adding a suitable binder to give it hardness, re-compacting and crushing to the correct size.

Depending on the application, a variety of equipment can be used for holding GAC including vessels, canisters, panels, filters, and adsorbers of a variety of sizes. Vessels containing 5 tons (10,000 pounds) of GAC have commonly been used for environmental and industrial stormwater treatment. GAC has a long history of proven effectiveness in removing metals and organic materials, but as previously described it must be protected against clogging. Many water quality treatment equipment vendors can provide GAC filtration units.

5 Recommended Dredge Return Water Treatment Criteria

TBT is a highly toxic biocide that has been used extensively to protect the hulls of large ships. The EPA established acute and chronic water quality criteria for TBT in saltwater (EPA, 2003), which are summarized in Table 5-1. The EPA intended these water quality criteria to be used as water quality standards for TBT.

Table 5-1: Water Quality Criteria^{1,2} for Tributyltin	
Saltwater Aquatic Life	
Acute toxic effect	0.42 µg/L
Chronic toxic effect	0.0074 µg/L
Notes:	
1	Acute toxicity criterion is implemented as a 1 hour average, not be exceeded more than once every 3 years on average.
2	Chronic toxicity criterion is implemented as a 4-day average, not to be exceeded more than once every 3 years on average.
µg/L – micrograms per liter.	

TBT-contaminated water will be generated from water pumped from a decant barge and from water collected from the upland sediment dewatering staging area. Water from both sources will be treated to remove TBT to below the water quality criteria prior to the points of compliance as discussed below.

The Section 401 Water Quality Certification (WQC) for the Boeing Plant 2 Early Action Area dredging project provides recent precedent in the application of water quality criteria for in-water dredging and dredge return water discharge to surface water. The U.S. Corps of Engineers provided the Section 401 WQC on November 20, 2012 (Order No. 9623, Corps NWS-20110384-SO) for the environmental dredging of PCB-contaminated sediment. Table 5-2 summarizes the points of compliance and water quality standards applied in the Section 401 WQC for the Boeing Plant 2 Early Action Area. The mixing zones in the Lower Duwamish Waterway were developed from WAC 173-201A-400 (Mixing Zones) and WAC 173-201A-410 (Short-Term Modifications).

Activity	Standards^{1,2}	Point of Compliance
Dredge return water discharge	Acute and conventional parameters	End of pipe
	Chronic	150 feet radius from the outfall discharge point
In-water dredging	Acute and conventional parameters	150 feet radius from the dredging location
	Chronic	300 feet radius from the dredging location
In-water construction (i.e., outfalls, piling removal, shoreline modifications)	Turbidity (visual)	150 feet from the in-water work
Notes:		
1 Acute and chronic indicate acute and chronic toxic substances criteria		
2 Conventional parameters include turbidity, pH, dissolved oxygen, and temperature		

Table 5-3 summarizes the recommended water quality standards and points of compliance for dredge return water for the Phase 1 Removal Action Project based on precedent and identified toxicity data. Treated dredge return water effluent will be discharged to the Sitcum Waterway. As indicated in Figure 3, this waterway has been designated for “Good Quality” criteria (WAC 172-201A-612). The RAWP describes the dredge return water quality monitoring approach for the points of compliance at the end-of-pipe and at the mixing zone boundary.

The derivation of the EPA acute and chronic water quality criteria is based on calculations presented in the guidance document *Guidelines for Deriving Numerical National Water Quality Criteria for the Protection of Aquatic Organisms and their Uses* (EPA, 1985). The EPA acute marine aquatic life water quality criterion for dissolved TBT is 0.42 µg/L (EPA, 2003). The acute criterion is implemented as a 1-hour average, measured at the end of pipe (Acute Compliance Boundary), not to be exceeded more than once every 3 years on the average. The EPA chronic marine aquatic life water quality criterion for TBT is 0.0074 µg/L (EPA, 2003). The chronic criterion is implemented as a 4-day average, at the 150-foot radius from the outfall (edge of mixing zone – Chronic Compliance Boundary), not to be exceeded more than once every 3 years on the average. The recommended approach to dredge return water monitoring is provided in the RAWP.

Table 5-3: Recommended Water Quality Standards and Points of Compliance for Dredge Return Water for the Pier 4 Phase 1 Removal Action Project		
Parameter	End of Pipe	150-foot Radius from Outfall (Edge of Mixing Zone)
Tributyltin	0.42 µg/L	0.0074 µg/L
Turbidity	10 NTU over background when background is 50 NTU or less; or 20% over background when background is greater than 50 NTU	N/A
Notes: N/A – not applicable µg/L – micrograms per liter		

6 Dredge Return Water Quality

6.1 Anticipated Dredge Return Water Quality

The recommended dredge return water treatment system has been designed to remove turbidity and TBT from dredge water. The treatment train is intended to first remove larger particles including sand and gravel through pre-treatment settling, followed by electrocoagulation, settling and filtration to remove smaller particles and TSS, followed by polishing using GAC to remove dissolved organic TBT prior to discharge of the treated dredge return water.

The effluent from the recommended dredge return water treatment system (or an equivalent system) would not be anticipated to exceed the water quality of the receiving marine water. Water quality compliance monitoring will be performed to evaluate and confirm the performance of the dredge return water treatment system, and to ensure that the dredge return water satisfies performance criteria in EPA's 401 Water Quality Memorandum. As described in Section 2, the influent to the dredge return water treatment system is anticipated to be below the 0.42 µg/L acute criterion for TBT. Thus, TBT exceedances should not occur at the end-of-pipe Acute Compliance Boundary when the recommended or equivalent dredge return water treatment system is used and properly operated and maintained.

It is important to note that the recommended dredge return water treatment system described in Section 4 will provide ongoing, real-time internal monitoring for turbidity and pH that will be measured both within the treatment train and prior to effluent discharge. The internal monitoring will be used for system operation and control. The performance of individual system components will be tracked and automatically or manually adjusted as needed to maximize the performance of the treatment system. The internal monitoring will also serve as an early warning system, and the system can be set up to switch to recirculation mode (i.e., no discharge) in the event specific internal parameters and system requirements are not achieved.

6.2 Responses to Exceedance of Water Quality

Assuming the recommended treatment system (or an equivalent system) is used, a water quality criteria exceedance is not anticipated given the expected influent water quality. In the event of an exceedance of water quality criteria, treatment system discharge will immediately be stopped, and the following responses will be initiated:

- Review system turbidity monitoring data and other relevant control system information to evaluate effectiveness of treatment system components.
- Inspect the following system components:
 - Settling tanks
 - Electrocoagulation system
 - Mixed media filters
 - Other filter or clarifying units
 - GAC system

ASPECT CONSULTING

- Perform maintenance and system modifications as warranted.
- Re-sample end-of-pipe effluent turbidity and dissolved TBT while the treatment system is in the recirculation (no discharge) mode to confirm effectiveness of the operational changes.
- Based on results of re-sampling, implement one or more of the following if needed:
 - Perform additional adjustments to electrocoagulation system operation to improve effectiveness;
 - Switch GAC units from parallel to series operation and add additional GAC vessels if needed to increase GAC contact time;
 - Replace GAC in one or more vessels; and
 - Re-sample end-of-pipe turbidity and dissolved TBT to confirm that changes have been effective and that water quality criteria compliance can be achieved.

References

- Ayanda, O.S., O.S. Fatoki, F.A, Adekola, and B.J Ximba, 2013, Removal of Tributyltin from Shipyard Process Wastewater by Fly Ash, Activated Carbon, and Fly Ash/Activated Carbon Composite: Adsorption Model and Kinetics, *Journal of Chemical Technology and Biotechnology*, 88(12) 2201-2208, wileyonlinelibrary.com/jctb.
- AMEC Environmental & Infrastructure, Inc. (AMEC), 2013, 2012-2013 Construction Season Completion Report, Duwamish Sediment Other Area and Southwest Bank Corrective Measure and Habitat Project, Boeing Plant 2, Seattle/Tukwila, Washington, October 2013.
- Ashcroft, P.L. and D. Abel, 1999, Process Water Treatment for the Removal of TBT in Ship Washdown Waste Waters, *Proceedings of Oceans '99 Congress*, pp. 72-75, Provided in TBT CLEAN, 2003, Annex 7, pp. 107-109.
- Champ, M.A., T.J. Fox, and A.J. Means (editors), 1999, Treatment of Regulated Discharges from Shipyards and Drydocks, *Proceedings of the Special Sessions held at Oceans '99 in Seattle, Washington, September 13 to 16, 1999, Volume 4*, 1999 ISBN No. 0-933957-24-6, The Marine Technology Society.
- Cretens, W.J., 2011, Dewatering and Water Treatment Operations of the Ottawa River Sediment Remediation Project, *Proceedings of the Western Dredging Association (WEDA XXXI) Technical Conference and Texas A&M University (TAMU 42) Dredging Seminar*, pp. 392-400, Nashville, Tennessee, June 5-8, 2011.
- Doty, Liisa, 2014, personal communications between Liisa Doty (Watertectonics) and Tom Atkins (Aspect Consulting) on August 27, 2014.
- EPA, 2003, Ambient Aquatic Life Water Quality Criteria for Tributyltin (TBT) – Final, Office of Water, EPA/822/R-03/031, December 2003.
- EPA, 1996, Recommendations for Screening Values for Tributyltin in Sediments at Superfund Sites in Puget Sound, Washington, DCN 4000-09-013-AADS, 13-01-AADK, and 33-01-AAAV, Prepared by Roy F. Weston, Inc. for EPA Region 10, October 1996.
- EPA, 1985, Appendix B Response to Public Comments on “Guidelines for Deriving Numerical National Water Quality Criteria for the Protection of Aquatic Organisms and Their Uses.” *Federal Regist.* 50:30793-30796. July 1985.
- Fletcher, L.E. and J.A. Lewis, 1999, Regulation of Shipyard Discharges in Australia and the Potential of UV Oxidation for TBT Degradation in Washdown Waste Water, *Proceedings of Oceans '99 Congress*, pp. 27-35, Provided in TBT CLEAN, 2003, Annex 5, pp. 86-95.
- Floyd Snider, 2014, Pier 4 Phase 1 Removal Action Draft Removal Site Evaluation Report, Prepared for Port of Tacoma for submittal to EPA Region 10, September 2014.

- Fox, T.J., T. Beacham, G.C. Schafran, and M.A. Champ, 1999, Advanced Technologies for Removing TBT from Ship Washdown and Drydock Runoff Wastewaters, Proceedings of Oceans '99 Congress, pp. 63-71, Provided in TBT CLEAN, 2003, Annex 6, pp. 97-105.
- Fuglevand, P.F. and R.S. Webb, 2006, Water Management during Mechanical Dredging of Contaminated Sediment, Proceedings of the Western Dredging Association (WEDA XXVI) Technical Conference and Texas A&M University (TAMU 38) Dredging Seminar, pp. 461-468, San Diego, California, June 25-28, 2006.
- Interstate Technology Regulatory Council (ITRC), 2014, Electrocoagulation, Technology Overview as part of a Web-based Technical and Regulatory Guidance, Mining Waste Treatment Technology Selection, http://www.itrcweb.org/miningwaste-guidance/to_electrocoagulation.htm
- Messing, A., L.M. Ramirez, and T. Fox, 1997, A Review to Determine State-of-the-Practice Treatment Technologies for Reducing Concentrations of Organotin Compounds in Wastewater, <http://eng.odu.edu/casrm/tbt/LitReviewTBTtreatment1997.pdf>
- Platz, N., et al., 1999, Constructing a Pilot-Unit to Minimise the Organic Tin Compound and Heavy metal Contamination of Dock Wastewater, LIFE99 ENV/D/000414, Summarized in TBT CLEAN, 2003, pp. 31-34.
- Schafran, G.C., 2003, Evaluate Pilot and Full-Scale Treatment Processes to Remove TBT from Industrial Wastewater, May 2003, eng.odu.edu/casrm/tbt.htm.
- Scrimshaw, M.D., D. Hala, A.E. Okiemute, E. Cartmell, J.N. Lester, 2013, Removal Processes for Tributyltin During Municipal Wastewater Treatment, Water, Air, & Soil Pollution, 224:1400, January 2013.
- Stichnothe, H., J. Thoming, W. Calmano, 2001, Detoxification of Tributyltin Contaminated Sediments by an Electrochemical Process, The Science of the Total Environment, 266: 265-271, Provided in TBT CLEAN, 2003, Annex 4, pp. 71-77..
- TBT CLEAN, 2003, Screening of Technologies, LIFE02 ENV/B/000341, August 4, 2003.
- U.S. Army Corps of Engineers, 2012, Section 401 Water Quality Certification, Boeing Plant 2 Duwamish Sediment Other Area and Southwest Bank Corrective Measure and Habitat Project in Seattle/Tukwila, King County, Washington, Order No. 9623, Corps Reference No. NWS-2011-384-SO, November 20, 2012.
- WaterTectonics, 2014, BP2 – Duwamish River Remediation, <http://www.watertectonics.com/project/bp2-duwamish-river-remediation/>

Limitations

Work for this project was performed for the Port of Tacoma (Client), and this report was prepared in accordance with generally accepted professional practices for the nature and conditions of work completed in the same or similar localities, at the time the work was performed. This report does not represent a legal opinion. No other warranty, expressed or implied, is made.

All reports prepared by Aspect Consulting for the Client apply only to the services described in the Agreement(s) with the Client. Any use or reuse by any party other than the Client is at the sole risk of that party, and without liability to Aspect Consulting. Aspect Consulting's original files/reports shall govern in the event of any dispute regarding the content of electronic documents furnished to others.

FIGURES



Commencement Bay

PIER 4 RECONFIGURATION PROJECT LOCATION

Puyallup River
Sycum Waterway

Blair Waterway

Hylebos Waterway



Vicinity Map

Pier 4 Reconfiguration Project
Port of Tacoma
Tacoma, Washington

	SEP-2014	BY: TA/SCC	FIGURE NO. 1
	PROJECT NO. 140221	REVISED BY: ---	

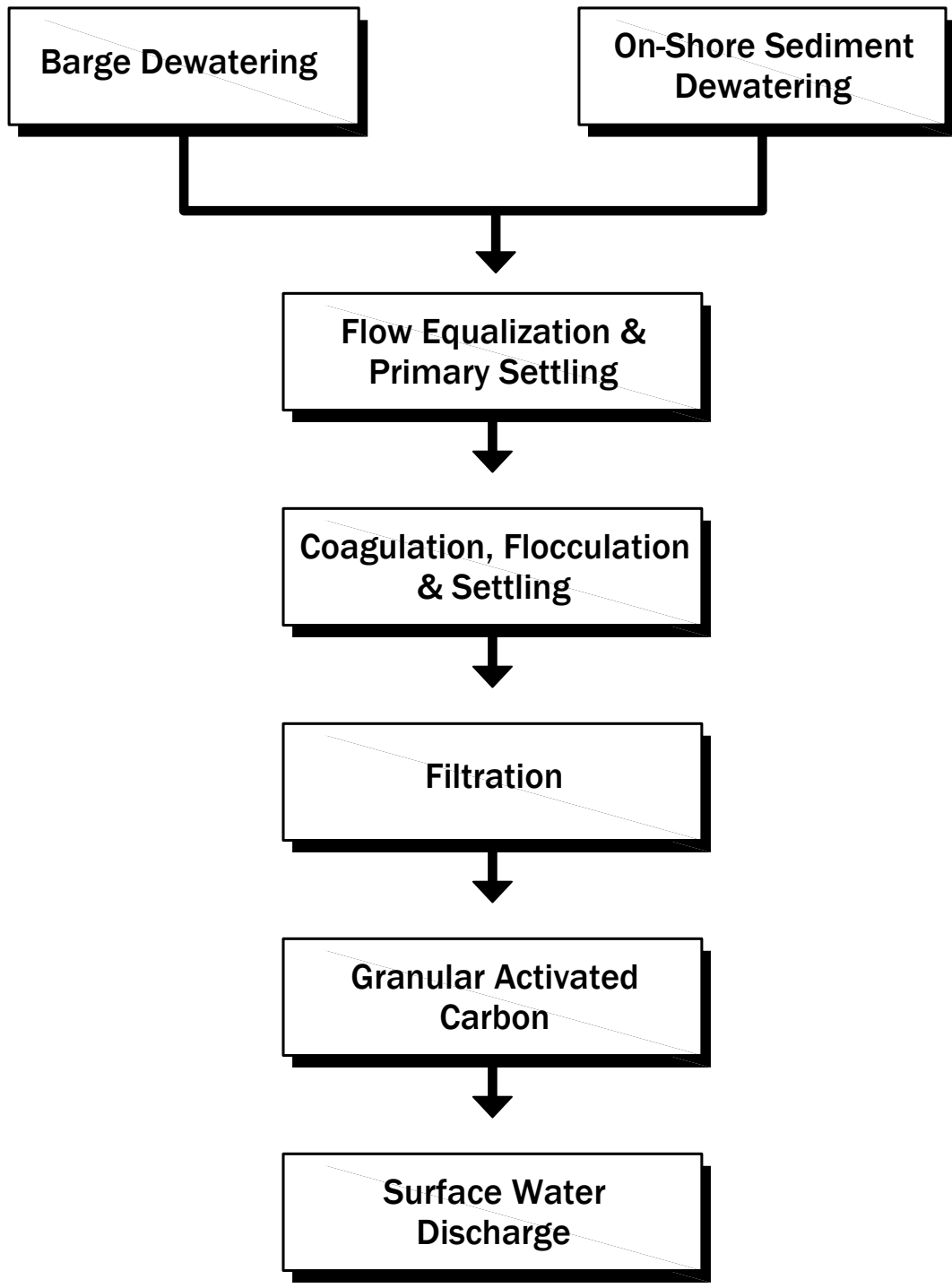

**Recommended Dredge Return Water
Treatment Train Schematic Diagram**

Pier 4 Reconfiguration Project
Port of Tacoma
Tacoma, Washington

	SEP-2014	BY: TA/SCC	FIGURE NO. 2
	<small>PROJECT NO. 140221</small>	<small>REVISED BY: SCC</small>	

Aquatic Life Use

- Extraordinary
- Excellent
- Good
- Fair

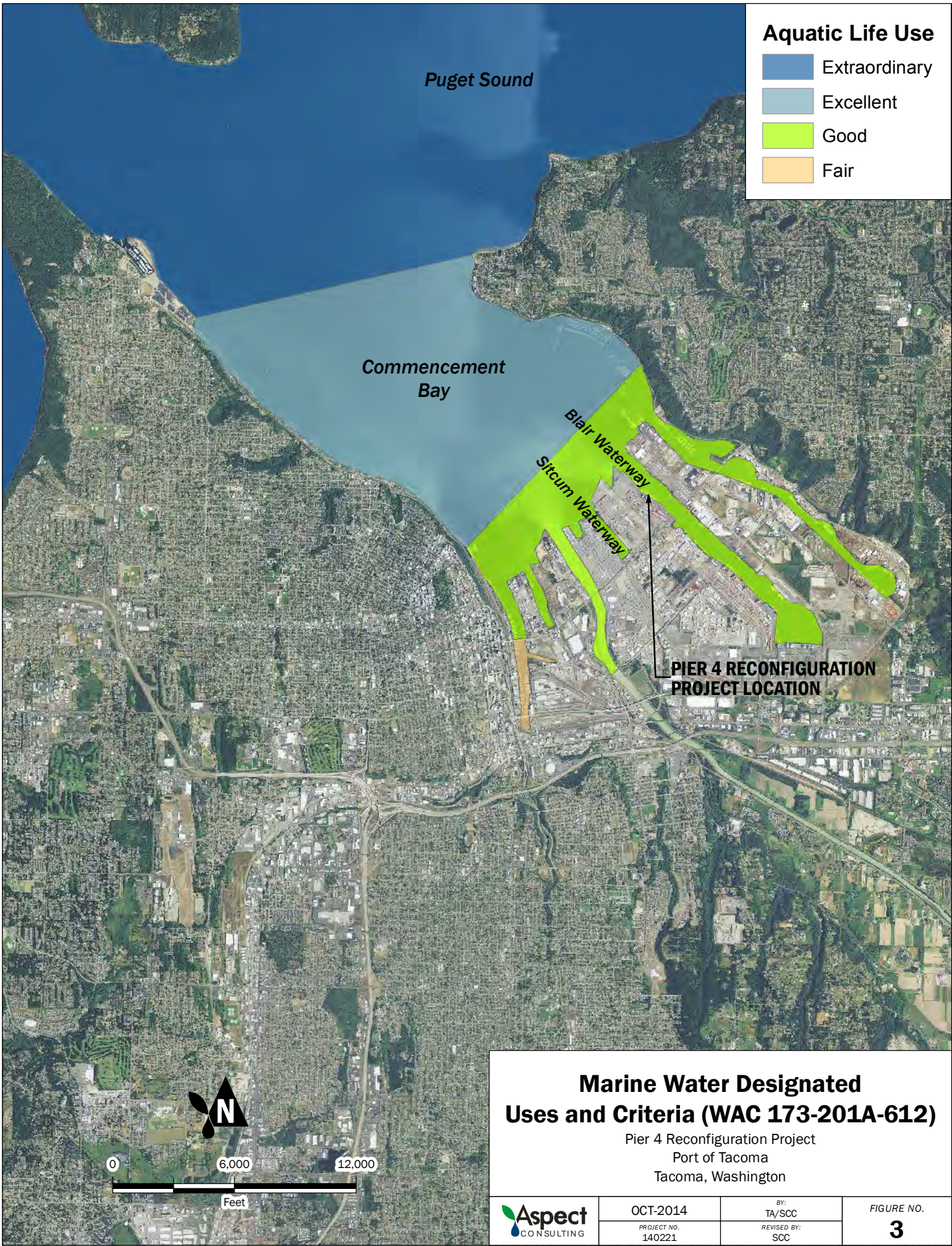

Puget Sound

Commencement Bay

Blair Waterway

Sicum Waterway

PIER 4 RECONFIGURATION PROJECT LOCATION

Marine Water Designated Uses and Criteria (WAC 173-201A-612)

Pier 4 Reconfiguration Project
Port of Tacoma
Tacoma, Washington

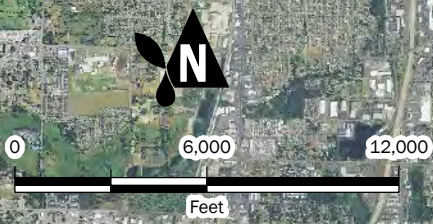

	OCT-2014	BY: TA/SCC	FIGURE NO. 3
	PROJECT NO. 140221	REVISED BY: SCC	

APPENDIX A

Precedent Dredging and Water Treatment Project Reports

- Ayanda, O.S., O.S. Fatoki, F.A. Adekola, and B.J Ximba, 2013, Removal of Tributyltin from Shipyard Process Wastewater by Fly Ash, Activated Carbon, and Fly Ash/Activated Carbon Composite: Adsorption Model and Kinetics, *Journal of Chemical Technology and Biotechnology*, 88(12) 2201-2208, wileyonlinelibrary.com/jctb.
- Index of TBT in Shipyard Washwaters literature, Center for Advanced Ship Repair and Maintenance (CASRM), Old Dominion University, www.eng.odu.edu/casrm.
- Champ, M.A., T.J. Fox, and A.J. Means (editors), 1999, Treatment of Regulated Discharges from Shipyards and Drydocks, Proceedings of the Special Sessions held at Oceans '99 in Seattle, Washington, September 13 to 16, 1999, Volume 4, 1999 ISBN No. 0-933957-24-6, The Marine Technology Society.
- Cretens, W.J., 2011, Dewatering and Water Treatment Operations of the Ottawa River Sediment Remediation Project, Proceedings of the Western Dredging Association (WEDA XXXI) Technical Conference and Texas A&M University (TAMU 42) Dredging Seminar, pp. 392-400, Nashville, Tennessee, June 5-8, 2011.
- Fuglevand, P.F. and R.S. Webb, 2006, Water Management during Mechanical Dredging of Contaminated Sediment, Proceedings of the Western Dredging Association (WEDA XXVI) Technical Conference and Texas A&M University (TAMU 38) Dredging Seminar, pp. 461-468, San Diego, California, June 25-28, 2006.
- Interstate Technology Regulatory Council (ITRC), 2014, Electrocoagulation, Technology Overview as part of a Web-based Technical and Regulatory Guidance, Mining Waste Treatment Technology Selection, http://www.itrcweb.org/miningwasteguidance/to_electrocoagulation.htm.
- Messing, A., L.M. Ramirez, and T. Fox, 1997, A Review to Determine State-of-the-Practice Treatment Technologies for Reducing Concentrations of Organotin Compounds in Wastewater, <http://eng.odu.edu/casrm/tbt/LitReviewTBTTreatment1997.pdf>.
- Schafran, G.C., 2003, Evaluate Pilot and Full-Scale Treatment Processes to Remove TBT from Industrial Wastewater, May 2003, eng.odu.edu/casrm/tbt.htm.
- Scrimshaw, M.D., D. Hala, A.E. Okiemute, E. Cartmell, J.N. Lester, 2013, Removal Processes for Tributyltin During Municipal Wastewater Treatment, *Water, Air, & Soil Pollution*, 224:1400, January 2013.
- TBT CLEAN, 2003, Screening of Technologies, LIFE02 ENV/B/000341, August 4, 2003.

Removal of tributyltin from shipyard process wastewater by fly ash, activated carbon and fly ash/activated carbon composite: adsorption models and kinetics

Olushola S. Ayanda,^{a*} Olalekan S. Fatoki,^a Folahan A. Adekola^b and Bhekumusa J. Ximba^a

Abstract

BACKGROUND: The removal of tributyltin (TBT) from shipyard process wastewater using fly ash, activated carbon and fly ash/activated carbon composite was investigated.

RESULTS: Adsorption experiments performed on TBT-contaminated artificial process wastewater revealed that the adsorption capacity of TBT increases with increase in the adsorbent amount, contact time, pH, stirring speed and initial TBT concentration. The adsorption isotherms and the kinetic data were well described by the Freundlich and pseudo-second-order kinetic model, respectively. The negative values of the Gibbs energy change (ΔG°) indicated the spontaneous nature of the adsorption and the positive values of the enthalpy change (ΔH°) showed that the adsorption process is endothermic. Optimal conditions for the adsorption of TBT from contaminated artificial process wastewater were applied to TBT removal from natural shipyard process wastewater and the results showed that 94.2%, 99.2% and 99.8% TBT were removed by the fly ash, activated carbon and fly ash/activated carbon composite, respectively.

CONCLUSION: This study showed that the precursors as well as the composite could be employed as efficient adsorbents for the removal of TBT from contaminated shipyard process wastewater with the composite material exhibiting the highest adsorption efficiency.

© 2013 Society of Chemical Industry

Keywords: organotin; tributyltin; shipyard process wastewater; adsorption; activated carbon and fly ash composite; GC-FPD

NOTATION

q_e	amount of TBT adsorbed at equilibrium per unit weight of the adsorbent (mg g^{-1})
q_t	amount of TBT adsorbed at any time (mg g^{-1})
k_1	pseudo-first-order rate constant (min^{-1})
k_2	rate constant of pseudo-second-order adsorption ($\text{g mg}^{-1} \text{min}^{-1}$)
h_0	initial adsorption rate ($\text{mg g}^{-1} \text{min}^{-1}$)
C_a	amount of adsorbed TBT on the adsorbent (mg g^{-1})
C_e	equilibrium concentration of TBT in the bulk solution (mg L^{-1})
C_0	initial concentration of the TBT aqueous solution
R	gas constant ($\text{J mole}^{-1} \text{K}^{-1}$)
k_L	Langmuir isotherm constant
A_{max}	maximum monolayer TBT adsorption capacity (mg g^{-1})
k_F	Freundlich isotherm constant
n_F	exponent in Freundlich isotherm
ΔG°	standard Gibbs free energy (kJ mol^{-1})
ΔH°	standard enthalpy change (kJ mol^{-1})
ΔS°	standard entropy change ($\text{J K}^{-1} \text{mol}^{-1}$)

T	absolute temperature
K_c	thermodynamic equilibrium constant

INTRODUCTION

Tributyltin (TBT) is an organic tin compound that is widely used in biocides, wood preservatives and antifouling paints. The use of TBT has led to serious contamination of the environment and causes harmful effects on aquatic organisms such as imposex in gastropods and abnormal embryonic development in sea urchins and marine invertebrates.¹ Although the use of TBT-containing paints has been banned, developing countries are still using TBT in

* Correspondence to: Olushola S. Ayanda, Department of Chemistry, Faculty of Applied Sciences, Cape Peninsula University of Technology, P.O. Box 1906, Bellville, South Africa. Email: osayanda@gmail.com

^a Department of Chemistry, Faculty of Applied Sciences, Cape Peninsula University of Technology, P.O. Box 1906, Bellville, South Africa

^b Department of Chemistry, University of Ilorin, P.M.B 1515, Ilorin, Nigeria

antifouling paints because of its effectiveness, hence, high concentrations of TBT can still be found in the marine environment. Efforts are therefore being made to reduce the concentration of TBT in shipyard process wastewater to >99% reduction before discharge into the aquatic environment. The suitability of anode materials to remove TBT from shipyard process waters has been reported by Calmano and Arevalo.² Tam *et al.*³ also investigated the biosorption and biodegradation of TBT by free cells of a resistant microalgal species. Hoch *et al.*⁴ studied the adsorption and desorption behavior of TBT from aqueous solution to clay-rich sediments. Song *et al.*⁵ reported the removal of TBT from wastewater by extraction with diesel oil. Prasad and Schafran⁶ reported the use of a full-scale process train consisting of coagulation–flocculation, dissolved air flotation, sand filtration and a series of two granular activated carbon (GAC) filters for removal of TBT, and Vreysen *et al.*⁷ investigated the removal of TBT from shipyard wastewaters by a one-step adsorption–flocculation method.

Activated carbon is a very efficient adsorbent for removing varieties of environmental pollutants including TBT⁶ from wastewater due to its high surface area, porosity, and physicochemical characteristics; however, its use is limited due to its high cost and low selectivity.⁸ Fly ash, a by-product of coal combustion process, is a low cost adsorbent, and is effective for the removal of contaminants in water and wastewater.^{9,10} Fly ash/activated carbon composite preparations results in improved physicochemical properties and reduces the cost of using activated carbon alone for the remediation of environmental pollutants. The kinetics and equilibrium data on the sorption of TBT from wastewaters to carbon are limited and no work has been reported on the use of fly ash and/or fly ash/activated carbon composite for the removal of TBT.

In the present work, adsorption characteristics of fly ash, activated carbon and fly ash/activated carbon composite have been studied with a view to demonstrating the role of these materials in controlling TBT pollution. Adsorption data have been analyzed with adsorption models to determine the mechanistic parameters associated with the adsorption process, the kinetics of adsorption were also investigated and the results obtained on the effect of temperature at optimum conditions have been used to determine the thermodynamic parameters.

METHODS AND MATERIALS

Adsorbents

Fly ash from Matla power station, Mpumalanga, South Africa was used in this study. Activated carbon (100–400 mesh) was purchased from Sigma Aldrich, USA. Composite material involving fly ash and activated carbon in the ratio 1:1 was prepared by the method reported by Fatoki *et al.*⁸ The physicochemical properties of the precursors and the composite are listed in Table 1.

Chemical reagents

Tributyltin chloride (purity 98%), methanol, hexane, acetic acid, sodium hydroxide and sodium tetraethylborate (NaBEt₄) were purchased from Sigma Aldrich, USA while carbonate, sulphate and chlorides salts for the preparation of artificial seawater were supplied by Merck. Stock solution containing 1000 mg L⁻¹ TBT was prepared by dissolving the organotin compound in methanol, and was stored in the dark at 4 °C. Working solutions were prepared daily. Working solutions of the derivatization agent were made up daily by dissolving 1.0 g NaBEt₄ in 100 mL of methanol (1% NaBEt₄) while acetate buffer (3 mL acetic acid, 4.0 g sodium acetate, in 1 L of Milli-Q water resulting in pH 4.5) was also prepared.

Table 1. Physicochemical properties of fly ash, activated carbon and fly ash/activated carbon composite

Characteristics	Activated carbon	Fly ash	Fly ash/activated carbon
pH	3.30	10.70	3.52
PZC	2.06	12.17	3.19
Surface area (m ² g ⁻¹)	1156.60	1.06	5.30
Micropore area (m ² g ⁻¹)	442.7	0.38	0.19
Ash content (%)	0.45 ± 0.07	97.40 ± 0.14	46.30 ± 0.14
Carbon content (%)	71.40	1.54	36.83
Nitrogen content (%)	0.35	BD	BD
Hydrogen content (%)	2.82	BD	2.72

BD- below detection limit.

TBT-contaminated shipyard process wastewater was simulated in the laboratory, prepared by spiking artificial seawater with TBT stock solution. The artificial seawater was prepared by the addition of 86.6 mL of 5 mol L⁻¹ NaCl, 9.0 mL of 1.0 mol L⁻¹ KCl, 9.27 mL of 1.0 mol L⁻¹ CaCl₂·2H₂O, 4.68 mL of 4.9 mol L⁻¹ MgCl₂·2H₂O, 12.75 mL of 2.0 mol L⁻¹ MgSO₄·7H₂O and 2.15 mL of 1.0 mol L⁻¹ NaHCO₃ all diluted to 1 L with Milli-Q water, which resulted in pH 8 (marine condition). TrisHCl-buffer was not used in the preparation of artificial seawater because it resulted in a lower pH.¹² TrisHCl-buffer and NaOH solution were used to adjust the pH during study of the effect of pH. The physicochemical properties of the shipyard process wastewater obtained from Cape Town harbor were: turbidity (3.26 NTU), pH (7.5), conductivity (37.56 mS cm⁻¹), TDS (18.78 ppt), salinity (22.65 psu), resistivity (26.60 ohms) and 4.615 mg L⁻¹ TBT concentration.

Analysis of tributyltin

The concentration of TBT in artificial or natural shipyard process wastewater before and after the adsorption studies was determined after derivatization by the addition of 1 mL of acetate buffer (pH = 4.5) and 1.0 mL of 1% NaBEt₄ and extraction into hexane by horizontal shaking in a separation funnel. The extracts were reduced to 1 mL and analysed by gas chromatography–flame photometric detector (GC-FPD) (Shimadzu GC-2010 Plus) with a capillary column HP 5 (5% phenyl methyl siloxane, 30 m × 0.25 mm i.d., film thickness 0.25 μm). The temperature was programmed as follows: initially at 60 °C hold for 1 min, then heated to 280 °C at 10 °C min⁻¹, hold for 4 min. The injection and detector temperatures were 270 °C and 300 °C, respectively, and the carrier gas was high purity helium.

The limit of detection and quantification of the analytical method were determined according to EURACHEM guidelines.¹³ Blank matrices without sample were injected, and the blank signal measured. The limit of detection (LOD = 0.0001 mg L⁻¹) and limit of quantification (LOQ = 0.0010 mg L⁻¹) were calculated from the mean and standard deviation of 10 blank measurements with 95% confidence level.

The regression analysis carried out on signal intensities obtained for 6.25, 12.5, 25, 50 and 100 mg L⁻¹ working standards of TBT, showed a correlation coefficient of 0.9985. The linearity of the standards calibration concentration of TBT analyzed under the same conditions was 38.75 ± 0.05 mg L⁻¹ and the precision of measurement was represented by the relative standard deviation (RSD) which ranged from 8.83–10.5% for the between-sample reproducibility aliquots of TBT.

Adsorption experiments

The adsorption experiments of TBT onto fly ash, activated carbon and fly ash/activated carbon composite were conducted in batch mode, which permits complete evaluation of parameters that influence the adsorption process. Adsorption experiments were conducted in which TBT-contaminated artificial process wastewater was introduced into 250 mL Erlenmeyer flasks containing accurately weighed amounts of the adsorbent. The flasks were shaken by orbital shaker at room temperature (20 °C) for a prescribed length of time to obtain equilibrium. The adsorbents were then removed by filtration and the equilibrium concentrations of TBT were determined. The concentration of TBT remaining in the solution was calculated by taking the difference of initial and final TBT concentrations. The adsorption capacities were obtained by mass balance equation:

$$q = \frac{(c_o - c_e)V}{W} \quad (1)$$

where q is the equilibrium adsorption capacity per gram dry weight of the adsorbent, mg g^{-1} ; c_o is the initial concentration of TBT in the solution, mg L^{-1} ; c_e is the final or equilibrium concentration of TBT in the solution, mg L^{-1} ; V is the volume of the solution, L; and W is the dry weight of the adsorbent, g.

The adsorption kinetics experiments were conducted at room temperature using 100 mg L^{-1} of TBT solutions with 0.5 g of adsorbents per 25 mL keeping pH at 8, a stirring speed of 200 rpm and a contact time of 10–70 min. The data obtained were analyzed with pseudo-first-order and pseudo-second-order kinetic models.

The adsorption isotherms were investigated by varying the initial TBT concentration from 12.5 to 200 mg L^{-1} at optimized adsorbent dose, contact time, pH and stirring speed established after optimization of working parameters. The equilibrium data were fitted by Langmuir and Freundlich isotherm models.

The effect of pH on TBT adsorption was studied by varying the pH in the range 3 to 9. The effect of stirring speed on TBT adsorption was studied by varying the mixing speeds from 160 to 200 rpm. The effect of temperature on the adsorption of TBT was evaluated after optimization of all the working parameters for TBT adsorption at an initial TBT concentration of 100 mg L^{-1} solution with 0.5 g of adsorbents per 25 mL, pH 8, contact time 60 min and stirring speed 200 rpm from where the thermodynamic parameters of TBT adsorption in artificial process wastewater were obtained.

RESULTS AND DISCUSSION

Optimization of the adsorbent dose and contact time

The effect of adsorbent dose on the adsorption of TBT by the fly ash, activated carbon and fly ash/activated carbon composite is shown in Fig. 1. It was observed that the percentage adsorption increased with increasing adsorbent dose, reaching an optimum at 0.5 g for the fly ash, activated carbon and fly ash/activated carbon composite, corresponding to 89.1%, 99.7% and 99.6% removal, respectively.

The increase in the adsorption yields with increasing amounts of adsorbent can be explained by more adsorptive binding sites due to more adsorbent in the medium at higher dosages. The later constant trend in adsorption yields may be due to saturation of these sites on the adsorbent surface by the TBT molecules.¹⁴ Determination of an optimum amount of adsorbent is important for TBT removal in order to provide a cost-effective adsorption system.¹⁵ 0.5 g was therefore selected as the optimum adsorbent amount utilized for further studies.

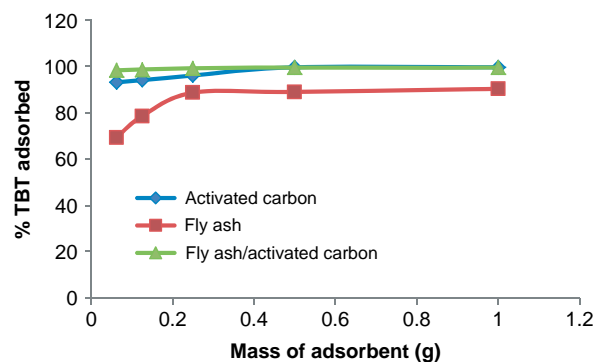

Figure 1. Adsorption efficiencies of TBT onto fly ash, activated carbon and fly ash/activated carbon composite. Experimental conditions: concentration of TBT = 100 mg L^{-1} ; volume of TBT solution = 25 mL, contact time = 60 min; stirring speed = 160 rpm, temperature = 20 °C.

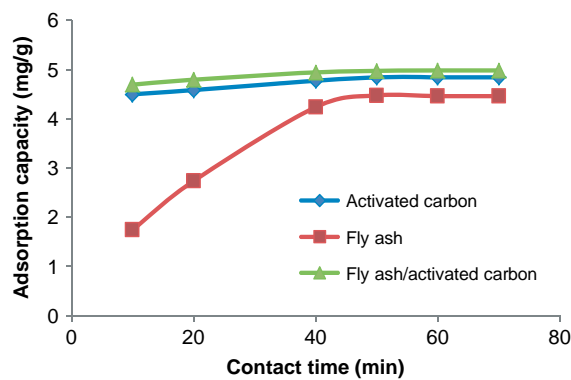

Figure 2. Effect of contact time on TBT adsorption onto fly ash, activated carbon and fly ash/activated carbon composite. Experimental conditions: concentration of TBT = 100 mg L^{-1} ; volume of TBT solution = 25 mL, mass of adsorbent = 0.5 g; stirring speed = 160 rpm, temperature = 20 °C.

Figure 2 shows the effect of contact time on the adsorption of TBT by the precursors and the composite material. The TBT removal efficiencies at different times ranging from 10 to 70 min were obtained.

The figure indicates that the adsorption rate was fast in the beginning of the process for all the adsorbents. It was also observed that equilibrium was achieved within approximately 60 min and the corresponding TBT removal for fly ash, activated carbon and fly ash/activated carbon composite of an initial concentration of 5.0 mg g^{-1} TBT reached 4.458 mg g^{-1} , 4.841 mg g^{-1} and 4.979 mg g^{-1} , respectively. A contact time of 60 min was therefore selected as the optimum contact time used in further studies.

Kinetic modeling

In order to investigate the mechanism and to determine the rate controlling step of the adsorption of TBT on fly ash, activated carbon and fly ash/activated carbon composite, kinetic models were used. The rate constants were calculated by pseudo-first-order and pseudo-second-order kinetic models.¹⁶

Pseudo-first-order model

The pseudo-first-order model is generally expressed as follows:

$$\log(q_e - q_t) = \log q_e - \frac{k_1}{2.303}(t) \quad (2)$$

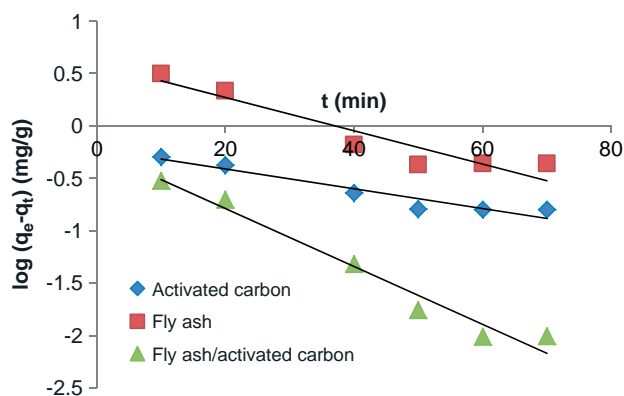

Figure 3. Pseudo-first-order rate equation plot for TBT adsorption onto fly ash, activated carbon and fly ash/activated carbon composite.

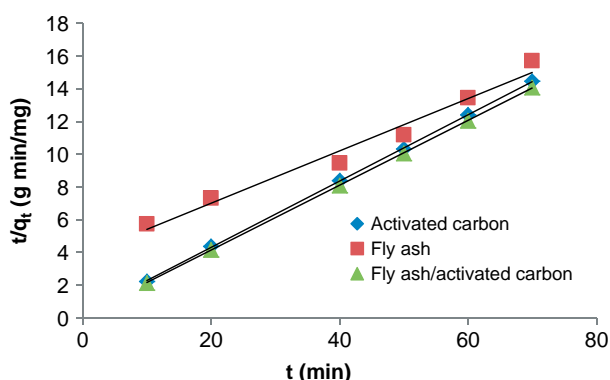

Figure 4. Pseudo-second-order rate equation plot for TBT adsorption onto fly ash, activated carbon fly ash/activated carbon composite.

where q_e is the amount of TBT adsorbed per unit weight of adsorbent at equilibrium, i.e. adsorption capacity (mg g^{-1}), q_t is the amount of adsorbent adsorbed (mg g^{-1}) at any time t and k_1 is the rate constant. The value of k_1 was calculated from the slope of the linear plot of $\log(q_e - q_t)$ versus t .

The pseudo-second-order rate model

The pseudo-second-order rate model is given as follows:

$$\frac{t}{q_t} = \frac{1}{h_o} + \frac{1}{q_e} (t) \quad (3)$$

where k_2 is the rate constant. The values of k_2 can be determined from the plot of $\frac{t}{q_t}$ versus t , furthermore, the initial rate of adsorption (h) ($\text{mg g}^{-1} \text{min}^{-1}$), when $t \rightarrow 0$, can also be calculated using following formula:

$$h = k_2 q_e^2 \quad (4)$$

Figure 3 and 4 show the pseudo-first-order and pseudo-second-order kinetic plots, respectively, and Table 2 provides the evaluated parameters of the kinetic models.

The value of the correlation coefficient (R^2) of the pseudo-second-order kinetic model (>0.97) is higher than the correlation coefficient of the pseudo-first-order model, indicating that the best kinetic model for the adsorption of TBT onto the precursors and composites is pseudo-second-order. The value of the initial

Table 2. Kinetic model parameters for TBT adsorption onto activated carbon, fly ash and fly ash/activated carbon composite

Models	Activated carbon	Fly ash	Fly ash/activated carbon
Pseudo-first-order			
k_1 (min^{-1})	0.0216	0.0366	0.0638
q_e (mg g^{-1})	0.5944	3.8824	0.5812
R^2	0.9200	0.8925	0.9680
Pseudo-second-order			
q_e (mg g^{-1})	4.9309	6.2617	5.0480
h_o ($\text{mg g}^{-1} \text{min}^{-1}$)	4.0650	0.2617	5.8038
k_2 ($\text{g mg}^{-1} \text{min}^{-1}$)	0.1672	0.0067	0.2278
R^2	0.9999	0.9762	0.9999

adsorption rate, h_o , obtained for the pseudo-second-order kinetics decreased as follows: $5.8038 \text{ mg g}^{-1} \text{min}^{-1}$ (fly ash/activated carbon composite) $> 4.0650 \text{ mg g}^{-1} \text{min}^{-1}$ (activated carbon) $> 0.2617 \text{ mg g}^{-1} \text{min}^{-1}$ (fly ash) indicating that fly ash/activated carbon composite and activated carbon can sorb TBT more rapidly than fly ash.

The pseudo-second-order kinetic model depends on the assumption that chemisorption is the rate-limiting step for the adsorption of TBT on the adsorbents. In chemisorption, the TBT ions stick to the adsorbent surface by forming a chemical (usually covalent) bond and tend to find sites that maximize their coordination number with the surface.¹⁷

Optimization of pH and stirring speed

The effect of pH on the adsorption of TBT onto the adsorbents was studied at pH 3–9. It was observed (Fig. 5) that the percentage of TBT adsorbed by the adsorbents steadily increased as the pH of the solution was increased from pH 3 to pH 8, and reached equilibration at $\text{pH} \geq 8$. This is in support of the results obtained by Fang et al.¹⁸ and Weidenhaupt et al.¹⁹

Maximum adsorption capacity was therefore recorded within the pH range of normal saline water (pH 8). About 89.5%, 96.9%, and 99.6% of TBT were removed from the initial concentration of 5 mg g^{-1} TBT by the fly ash, activated carbon and fly ash/activated

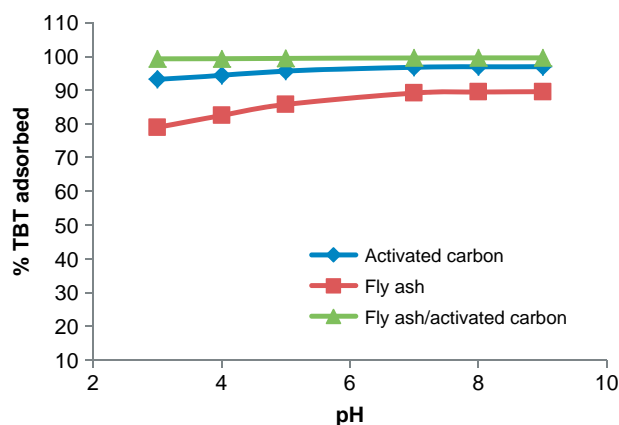

Figure 5. Effect of pH on TBT adsorption onto fly ash, activated carbon and fly ash/activated carbon composite. Experimental conditions: concentration of TBT = 100 mg L^{-1} ; volume of TBT solution = 25 mL, mass of adsorbent = 0.5 g; contact time = 60 min; stirring speed = 160 rpm, temperature = 20°C .

carbon composite, respectively, at a contact time of 60 min, stirring speed 160 rpm, temperature 20 °C and pH 8. The order of decreasing adsorption capacity was thus fly ash/activated carbon composite > activated carbon > fly ash. pH 8 was chosen as the optimum pH and was used for further studies.

The effect of stirring speed on the adsorption of TBT onto the adsorbents was studied at stirring speeds 160–200 rpm. The adsorption capacity of the adsorbents increased as the stirring speed of the mixture was increased, reaching equilibration at 200 rpm. Maximum amount of 4.726 mg g⁻¹, 4.963 mg g⁻¹ and 4.988 mg g⁻¹ of TBT were removed from the initial concentration of 5 mg g⁻¹ TBT by the fly ash, activated carbon and fly ash/activated carbon composite, respectively, at a contact time of 60 min, pH 8, temperature 20 °C and a stirring speed 200 rpm (Fig. 6). A stirring speed of 200 rpm was therefore used for further studies.

Effect of initial TBT concentration

Figure 7 shows that the adsorption of TBT on the adsorbents increased as the initial TBT concentration was increased from 12.5 to 100 mg L⁻¹, indicating that adsorption is also favorable for the higher TBT concentrations investigated. The increase in adsorption capacity with increase in initial TBT concentration is as a result of the increase in driving force due to the concentration gradient developed between the bulk solution and surface of the adsorbents. At higher TBT concentrations, the active sites of the adsorbents were surrounded by more TBT and the process of adsorption continues, leading to an increased uptake of TBT from the solution.

Adsorption isotherm parameters

Adsorption isotherms were determined to quantify the interaction between solute and the adsorbents, critical in optimizing the purification process. Two isotherm models (Langmuir and Freundlich) were employed to understand the equilibrium data and deduce an adsorption mechanism. The linear form of the Langmuir model²⁰ is:

$$\frac{c_e}{c_a} = \frac{1}{A_{\max}k_L} + \frac{1}{A_{\max}}c_e \quad (5)$$

where c_e (mg L⁻¹) is the equilibrium concentration of TBT in the solution, c_a (mg g⁻¹) is the TBT adsorption capacity for the adsorbents at equilibrium, A_{\max} (mg g⁻¹) is the maximum monolayer TBT adsorption capacity, and k_L (L mg⁻¹) is the Langmuir

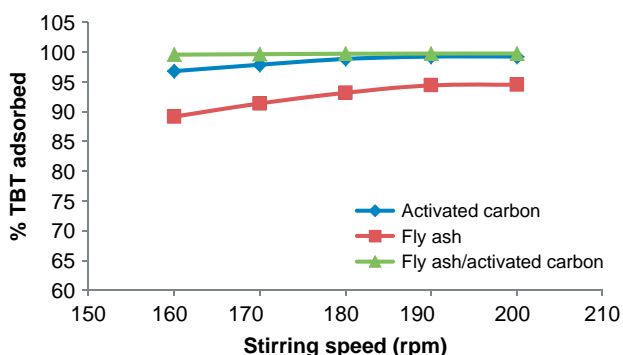

Figure 6. Effect of stirring speed on TBT adsorption onto fly ash, activated carbon and fly ash/activated carbon composite. Experimental conditions: concentration of TBT = 100 mg L⁻¹; volume of TBT solution = 25 mL, mass of adsorbent = 0.5 g; contact time = 60 min; pH 8; temperature = 20 °C.

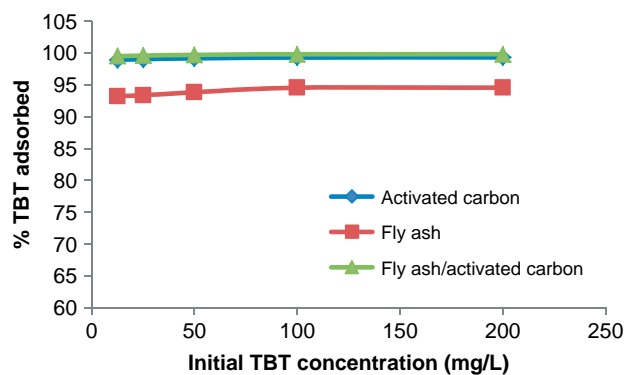

Figure 7. Percentage TBT adsorbed by the fly ash, activated carbon and fly ash/activated carbon composite at various initial TBT concentrations. Experimental conditions: volume of TBT solution = 25 mL, mass of adsorbent = 0.5 g; pH = 8; stirring speed = 200 rpm; contact time = 60 min; temperature = 20 °C.

isotherm constant related to the free energy of adsorption. When $\frac{c_e}{c_a}$ is plotted against c_e and the data are regressed linearly, A_{\max} and k_L constants are calculated from the slope and the intercept.

The linear form of the Freundlich model²⁰ is:

$$\log c_a = \log k_F + \frac{1}{n_F} \log c_e \quad (6)$$

The constant k_F [mg g⁻¹ (L mg⁻¹)^{1/n}] is related to the adsorption capacity of the adsorbents, and $\frac{1}{n_F}$ is related to the surface heterogeneity. When $\log c_a$ is plotted against $\log c_e$ and the data are analyzed by linear regression, $\frac{1}{n_F}$ and k_F constants can be determined from the slope and intercept.

The adsorption isotherm parameters²¹ obtained from the two models are given in Table 3. The experimental data fitted the Freundlich model well for all the adsorbents.¹² It is thus a more suitable model for describing the adsorption process because the regression coefficient (R^2) values (>0.98) are higher than for the Langmuir model (Table 3). The result therefore suggests the formation of multilayer coverage of TBT molecules at the outer surface of the adsorbents.²² The value of k_F determines the adsorption capacity of adsorbent at equilibrium concentration in a solution.²³ A higher k_F value corresponds to a higher adsorption capacity. According to the k_F values listed in Table 3, the adsorption capacity of TBT is higher for fly ash/activated carbon composite than for activated carbon, and that for activated carbon is in turn higher than for fly ash. The value of n_F , for all the adsorbents, falling in the range 1–10 also indicates favourable adsorption.

The negative value of the Langmuir constants, A_{\max} (mg g⁻¹) and k_L (L mg⁻¹) for TBT adsorption indicates the inadequacy of fitting of experimental data to the Langmuir model.²⁴ Thus, the Freundlich model was the best model to explain the adsorption behavior of TBT onto the adsorbents.

The solid residues before and after the adsorption processes were subjected to scanning electron microscopy (SEM) analysis and results are presented in Fig. 8. Micrographs of the adsorbents before and after adsorption showed that the spherical particles of fly ash²⁵ and the aggregated surfaces of activated carbon and fly ash/activated carbon composite were clearly seen before adsorption whereas TBT was deposited on the surfaces of these adsorbents after the adsorption process.

Table 3. Isotherms constants for the adsorption of TBT onto fly ash, activated carbon and fly ash/activated carbon composite

Equilibrium models	Activated carbon	Fly ash	Fly ash/activated carbon
Freundlich			
k_F (mg/g (L/mg) ^{1/n})	6.6589	0.6856	36.610
n_F	0.8375	0.9048	0.6799
R^2	0.9977	0.9990	0.9873
Langmuir			
k_L (L mg ⁻¹)	-0.2494	-0.0213	-1.4239
A_{max} (mg g ⁻¹)	-19.0476	-32.573	-7.3692
R^2	0.6952	0.7577	0.6622

Effect of temperature and thermodynamics

To investigate the effect of temperature on the adsorption process, K_c was calculated using Equation (7). The standard Gibbs free

energy ΔG° (kJ mol⁻¹) was obtained from Equation (8), while the values of the standard enthalpy change ΔH° (kJ mol⁻¹) and standard entropy change ΔS° (J K⁻¹ mol⁻¹) were calculated from the intercept and the slope of the linear plot of log K_c versus 1/T (Equation (9)).

$$K_c = \frac{c_a}{c_e} \tag{7}$$

$$\Delta G^\circ = -RT \ln K_c \tag{8}$$

$$\log K_c = \frac{\Delta S^\circ}{2.303R} - \frac{\Delta H^\circ}{2.303R} \cdot \frac{1}{T} \tag{9}$$

where c_a (mg L⁻¹) is the amount of TBT (mg) adsorbed on the adsorbent per liter of the solution at equilibrium, c_e (mg L⁻¹) is the equilibrium concentration of TBT in the solution, R is the universal gas constant, 8.314 J mol⁻¹ K⁻¹; T is absolute temperature and K_c is the thermodynamic equilibrium constant.

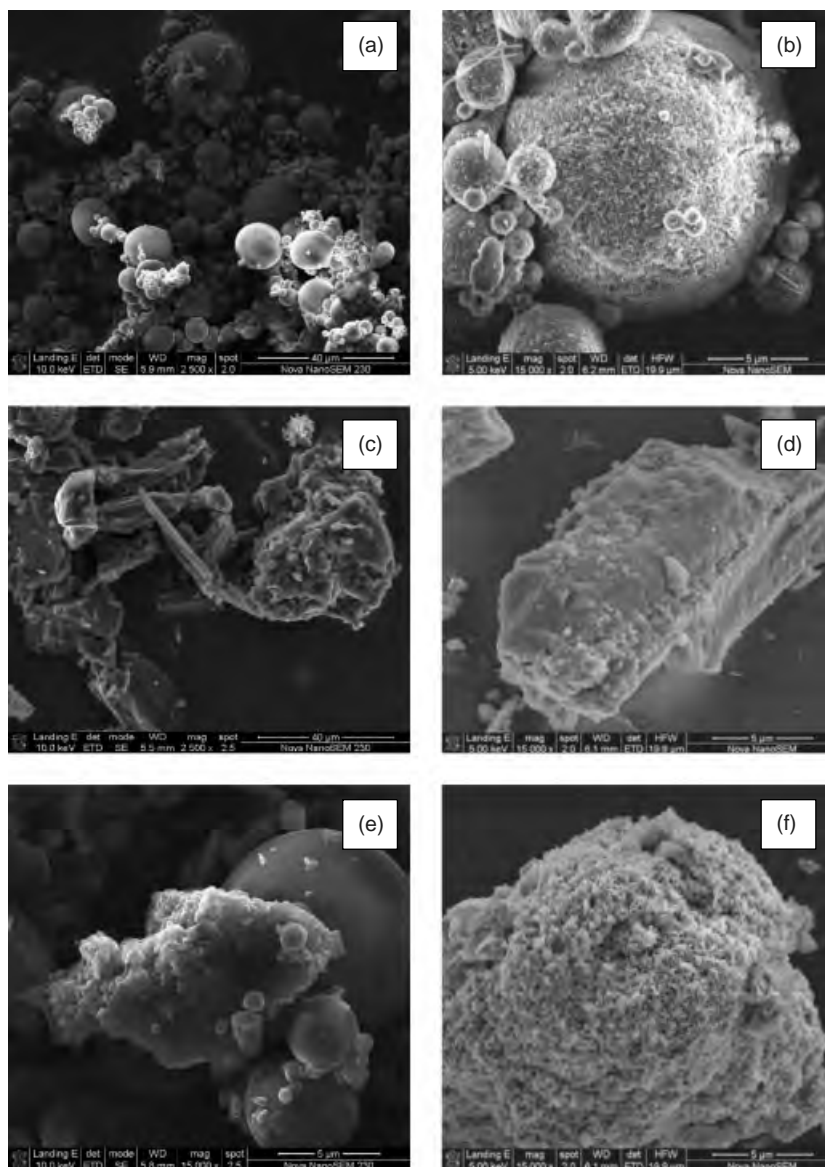

Figure 8. SEM of fly ash before (a) and after (b) TBT adsorption, activated carbon before (c) and after (d) TBT adsorption, and fly ash/activated carbon composite before (e) and after (f) TBT adsorption.

The adsorption data obtained in the temperature range 40–80 °C shows that the adsorption capacity of TBT onto all the adsorbents increases with increase in the solution temperature. This indicates that the adsorption of TBT onto the precursors and the composite is endothermic. The increase in the rate of adsorption with the increase in temperature may be attributed to the strong adsorptive forces between the active sites of the adsorbents and adsorbate species and also between the adjacent molecules of the adsorbed phases.²⁶

Approximately 95.7%, 99.9%, and 99.9% of TBT were removed from the initial concentration of 5 mg g⁻¹ TBT by the fly ash, activated carbon and fly ash/activated carbon composite, respectively, after a contact time of 60 min, at pH 8 and a stirring speed 200 rpm.

Figure 9 shows the Van't Hoff plot²⁷ for the adsorption of TBT and the thermodynamic parameters (ΔH° , ΔS° , ΔG° and K_c) are presented in Table 4.

The positive values of ΔH° for the intervals of temperatures also showed the endothermic nature of the adsorption process. The positive values of ΔS° correspond to an increase in degree of freedom of the adsorbed TBT and suggest an increase in

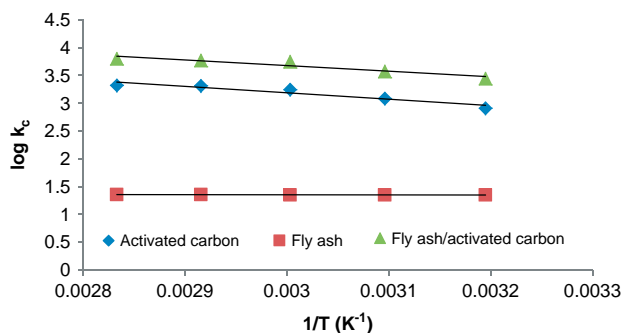

Figure 9. Van't Hoff plot for the adsorption of TBT onto fly ash, activated carbon and fly ash/activated carbon composite.

Table 4. Thermodynamic parameters for adsorption of TBT onto fly ash, activated carbon and fly ash/activated carbon composite

Temperature (°C)	ΔG° (kJ mol ⁻¹)	ΔS° (J K ⁻¹ mol ⁻¹)	ΔH° (kJ mol ⁻¹)	K_c
Fly ash				
40	-8.036	27.5853	0.5970	21.941
50	-8.312			22.100
60	-8.580			22.180
70	-8.867			22.414
80	-9.138			22.507
Activated carbon				
40	-17.434	127.830	22.293	812.00
50	-19.080			1218.5
60	-20.679			1753.4
70	-21.731			2039.8
80	-22.425			2082.3
Fly ash/activated carbon				
40	-20.634	128.414	19.363	2776.8
50	-22.066			3702.7
60	-23.872			5554.6
70	-24.751			5881.4
80	-25.651			6249.0

the concentration of adsorbate at the solid–solution interface, indicating an increase in adsorbate concentration onto the solid phase.²⁸

It is evident from Table 4 that ΔG° values were more negative as the temperature increased, indicating that the adsorption efficiency of TBT onto precursors and composite increased with increase in temperature and the adsorption of TBT onto all the adsorbents is a thermodynamically feasible process.²⁶

Application of optimized operating factors to the sorption of TBT in shipyard process wastewater

Optimal conditions for the adsorption of TBT from artificial process wastewater were applied to TBT removal from contaminated natural shipyard process wastewater. The result showed that approx. 94.2%, 99.2% and 99.8% TBT were removed by 0.5 g of fly ash, activated carbon and fly ash/activated carbon composite, respectively after a contact time of 60 min, at a temperature of 20 °C and stirring speed of 200 rpm under normal atmospheric condition.

CONCLUSION

The study has shown the potential of fly ash, activated carbon and fly ash/activated carbon composite to remove tributyltin from shipyard process wastewater. The TBT removal efficiency was in the order: fly ash/activated carbon composite > activated carbon > fly ash. The adsorption data suggest that all the operating factors considered in this study are important for the control of TBT adsorption. The percentage adsorption increases with increasing adsorbent dose, contact time, pH, stirring speed, initial TBT concentration and temperature. It is therefore evident that maximum adsorption can be achieved at normal saline water conditions (pH 8). The equilibrium data fit Freundlich isotherm model satisfactorily and the kinetic data were well described by the pseudo-second-order model. Thermodynamic analysis also showed that the adsorption process was endothermic and spontaneous in nature. The results of this experimental study are highly useful and the adsorbents may be extended to other organic pollutants in wastewater.

ACKNOWLEDGEMENT

Olushola S. Ayanda wishes to thank Cape Peninsula University of Technology, Cape Town, South Africa for the award of 2012 University Research Fund (URF).

REFERENCES

- Luan TG, Jin J, Chan SMN, Wong YS and Tam NTY, Biosorption and degradation of tributyltin (TBT) by alginate immobilized *Chlorella vulgaris* beads in several treatment cycles. *Process Biochem* **41**:1560–1565 (2006).
- Calmano W and Arevalo E, Studies on electrochemical treatment of wastewater contaminated with organotin compounds. *J Hazard Mater* **146**:540–545 (2007).
- Tam NFY, Chong A and Wong YS, Removal of tributyltin (TBT) by live and dead microalgal cells. *Marine Pollut Bull* **45**:362–371 (2002).
- Hoch M, Alonso-Azcarate J and Lischick M, Adsorption behavior of toxic tributyltin to clay-rich sediments under various environmental conditions. *Environ Toxicol Chem* **21**:1390–1397 (2002).
- Song YC, Woo JH, Park SH and Kim IS, A study of the treating of antifouling paint waste from shipyard. *Marine Pollut Bull* **51**:1048–1053 (2005).

- 6 Prasad R and Schafran GC, Characterisation of tributyltin in shipyard waters and removal through laboratory and full-scale treatment. *Water Res* **40**:453–462 (2006).
- 7 Vreysen S, Maes A and Wullaert H, Removal of organotin compounds, Cu and Zn from shipyard wastewaters by adsorption – flocculation: a technical and economical analysis. *Marine Pollut Bull* **56**:106–115 (2008).
- 8 Thuy PT, Anh NV and Bruggen B, Evaluation of two low-cost–high-performance adsorbent materials in the waste-to-product approach for the removal of pesticides from drinking water. *Clean Soil Air Water* **40**:246–253 (2012).
- 9 Laohaprapanon S, Marques M and Hogland W, Removal of organic pollutants from wastewater using wood fly ash as a low-cost sorbent. *Clean Soil Air Water* **38**:1055–1061 (2010).
- 10 Ayanda OS, Fatoki OS, Adekola FA and Ximba BJ, Characterization of fly ash generated from Matla power station in Mpumalanga, *South Africa*. *Eur J Chem* **9**:1788–1795 (2012).
- 11 Fatoki OS, Ayanda OS, Adekola FA, Ximba BJ and Opeolu BO, Preparation and characterization of activated carbon – nFe₃O₄, activated carbon – nSiO₂ and activated carbon – nZnO hybrid materials. *Part Part Syst Charact* **29**:178–191 (2012).
- 12 Brandli RC, Breedveld GD and Cornelissen G, Tributyltin sorption of marine sedimentary black carbon and to amended activated carbon. *Environ Toxicol Chem* **28**:503–508 (2009).
- 13 EURACHEM Guidelines, The Fitness for Purpose of Analytical Methods: A Laboratory Guide to Method Validation and Related Topics, EURACHEM Guide, LGC, Teddington, 1st English edn. 1998. <http://www.eurachem.ul.pt/>.
- 14 Deng LY, Xu GR, Yan ZC, Liu QH and Li GB, Removal effect of Cr (VI) by adsorbent made from sewage sludge. *Water Sci Technol* **62**:2961–2969 (2010).
- 15 Wang Y and Chu W, Adsorption and removal of a Xanthene dye from aqueous solution using two solid wastes as adsorbents. *Ind Eng Chem Res* **50**:8734–8741 (2011).
- 16 Jain CK, Adsorption of zinc onto bed sediments of the River Ganga: adsorption models and kinetics. *Hydrolog Sci J* **46**:419–434 (2001).
- 17 Atkins PW, *Physical Chemistry*, 5th sdn. Oxford University Press, Oxford (1995).
- 18 Fang L, Borggaard OK, Marcussen H, Holm PE and Hansen HCB, The pH-dependent adsorption of tributyltin to charcoals and soot. *Environ Pollut* **158**:3642–3649 (2010).
- 19 Weidenhaupt A, Arnold C, Müller SR, Haderlein SB and Schwarzenbach RP, Sorption of organotin biocides to mineral surfaces. *Environ Sci Technol* **31**:2603–2609 (1997).
- 20 Liang L, Luo L and Zhang S, Adsorption and desorption of humic and fulvic acids on SiO₂ particles at nano and micro-scales. *Colloids Surf A* **384**:126–130 (2011).
- 21 Basha S and Murthy ZVP, Kinetics and equilibrium models for biosorption of Cr(VI) on chemically modified seaweeds, *Cystoseira indica*. *Process Biochem* **42**:1521–1529 (2007).
- 22 Salman JM and Hameed BH, Removal of insecticide carbofuran from aqueous solution by banana stalks activated carbon. *J Hazard Mater* **176**:814–819 (2010).
- 23 Ignatowicz K, Selection of sorbent for removing pesticides during water treatment. *J Hazard Mater* **169**:953–957 (2009).
- 24 Maarof HI and Hameed BH, Adsorption isotherms for phenol onto activated carbon. *AJChE* **4**:70–76 (2004).
- 25 Jayasinghe GY, Tokashiki Y and Kinjo K, Recycling of coal fly ash and paper waste to improve low productive red soil in Okinawa, *Japan*. *Clean Soil Air Water* **37**:687–695 (2009).
- 26 Tabak A, Baltas N, Afsin B, Emirik M, Caglar B and Eren E, Adsorption of reactive Red 120 from aqueous solutions by cetylpyridinium-bentonite. *J Chem Technol Biotechnol* **85**:1199–1207 (2010).
- 27 Sheela T, Arthoba Nayaka Y, Viswanatha R, Basavanna S and Venkatesha TG, Kinetics and thermodynamics studies on the adsorption of Zn(II), Cd(II) and Hg(II) from aqueous solution using zinc oxide nanoparticles. *Powder Technol* **217**:163–170 (2012).
- 28 Alkan M, Demirbaş Ö, Çelikçapa S and Doğan M, Sorption of acid red 57 from aqueous solution onto sepiolite. *J Hazard Mater* **116**:135–145 (2004).

Home

Civil and
Environmental
Engineering
Department

College of
Engineering and
Technology

Old Dominion
University



TBT IN SHIPYARD WASHWATERS

Tributyltin (TBT) removal from shipyard washwaters and sonar dome water has been studied for over three years using full-scale field treatment, laboratory bench-top treatment, and both field and laboratory pilot-scale treatment processes. This work is ongoing and progress and final reports as well as proceedings papers are provided. Treatment efforts have included coagulation, clarification, filtration, GAC adsorption, UV irradiation, membranes, and ozonation.

CASRM TBT REPORTS

- Literature Review of TBT Treatment 1997
- TBT Borohydride Method NSRP
- March 2000 Progress Report
- February 2001 Progress Report
- TB Removal Paper April 2001
- May 2001 Progress Report
- August 2001 Progress Report
- February 2002 Progress Report
- May 2002 Progress Report
- August 2002 Progress Report
- November 2002 Progress Report
- February 2003 Progress Report
- May 2003 Progress Report

CONTACT INFORMATION:

Gary C. Schafran

Center for Advanced Ship Repair and Maintenance
Professor of Civil and Environmental Engineering
Old Dominion University
Norfolk, VA 23529-0241

PHONE:757-683-4673

FAX:757-683-5354

EMAIL:gschafra@odu.edu



**Oceans '99
MTS/IEEE**

**Leading the Crest into
the 21st Century**

DISTRIBUTION STATEMENT A
Approved for Public Release
Distribution Unlimited



Treatment of Regulated Discharges from Shipyards and Drydocks

Special Volume - Proceedings Oceans '99

DTIC QUALITY INSPECTED 4

20000803 113



IEEE
Networking the World™





*Proceedings of the Special Sessions held
at Oceans '99 in Seattle, Washington,
Sept 13-16, 1999 on:*

**“Treatment of Regulated
Discharges from Shipyards
and Drydocks”**

Michael A. Champ, Thomas J. Fox, and Alan J. Mearns
Proceedings Volume Editors

*Volume No. (4), 1999
ISBN No. 0-933957-24-6*

**The Marine Technology Society
Washington, D.C. 20036**

TABLE OF CONTENTS

Author's Index.....	ppg. v-vi
Preface	ppg. vii-x
Simulation of Stormwater Runoff from Marine Drydocks.....	ppg. 1-16
<i>Osman Akan, Gary C. Schafran, Peter Pommerenk, and Laura J. Harrell</i>	
Characterization of Shipyard Wastewater Streams	ppg. 17-26
<i>Bhaskar Kura, and Raghuram Tadimalla</i>	
Regulation of Shipyard Discharges in Australia and the Potential of UV Oxidation for TBT Degradation in Washdown Waste Water	ppg. 27-36
<i>Lyn E. Fletcher, and John A. Lewis</i>	
Real Time Copper Measurement (Of US Navy Dry Dock Effluent)	ppg. 37-40
<i>Mike Putnam</i>	
Discharge of Tributyltin Into State of Virginia Waters	ppg. 41-50
<i>David Johnson</i>	
Assessing the Degree of Appropriate Treatment of Shipyard and Drydock Wastewater Discharges and Stormwater Runoff.....	ppg. 51-62
<i>G. Fred Lee, and Anne Jones-Lee</i>	
Advanced Technologies for Removing TBT from Ship Washdown and Drydock Runoff Wastewaters	ppg. 63-72
<i>Thomas J. Fox, Thomas Beacham, Gary C. Schafran, and Michael A. Champ</i>	
Process Water Treatment for the Removal of TBT in Ship Washdown Waste Waters	ppg. 73-76
<i>Peter L. Ashcroft, and David Abel</i>	
Minimization and Treatment of Shipyard Wastewater	ppg. 77-90
<i>Bhaskar Kura, and Raghuram Tadimalla</i>	
Using Ground Recycled Glass in Abrasive Blasting to Reduce Shipyard Contamination	ppg. 91-94
<i>Fred Miller</i>	
Environmental Enclosure Systems for Industrial Ship Applications to Prevent Emissions and Discharges	ppg. 95-106
<i>Doug Randall</i>	

Development, Demonstration and Validation of Zero Discharge Industrial Waste Water Treatment Plant (IWTP) At Puget Sound Naval Shipyard (PSNS), Bremerton, WA	ppg. 107–118
<i>Katherine Ford, Walter Hunter, Ronald Bruening, Todd Lloyd, Greg Levcun, Linda Weavers, and Hugo Destailats</i>	
Contamination of Butyl- and Phenyltin Compounds in Sediment from Shipyards in Korea	ppg. 119–134
<i>Won Joon Shim, Jae Ryoung Oh, Nam Sook Kim, and Soo Hyung Lee</i>	
Overview of Stormwater General Sector Permits for Shipyards: A Federal Perspective	ppg. 135–136
<i>Joel H. Salter, Jr.</i>	
An Overview of the Science and Regulation of TBT and the Potential for Future Liability for Contaminated Harbor Sediments	ppg. 137–152
<i>Michael A. Champ</i>	
Cost Analysis of TBT Self-Polishing Copolymer Paints and Tin-Free Alternatives For Use On Deep-Sea Vessels	ppg. 153–168
<i>Nimmi Damodaran, John Toll, Mike Pendleton, Conrad Mulligan, David DeForest, Michael Kluck, Mary Sue Brancato, and John Felmy</i>	
Aquatic Ecological Risks Posed by Tributyltin in U.S. Surface Waters: PRE - 1989-1996 Data	ppg. 169–176
<i>Rick Cardwell, Mary Sue Brancato, John Toll, David DeForest, and Lucinda Tear</i>	
An Evaluation of Risks to U.S. Pacific Coast Sea Otters Exposed to Tributyltin	ppg. 177–184
<i>D. MacLellan, Mary Sue Brancato, David DeForest, and J. Volosin</i>	
Impacts of Invasive Species Introduced Through the Shipping Industry - An Overview and the Role of Policy-Makers	ppg. 185–192
<i>Mary Sue Brancato, D. MacLellan, and D. Hammons</i>	
Assessing the Impact of Antifouling Compounds in the Marine Environment. Lessons to be Learned from the Use and Misuse of Biological Indicators of TBT Contamination	ppg. 193–196
<i>Stewart M. Evans, G.J. Nicholson</i>	
An Overview of the Science and Regulation of TBT and the Potential for Future Liability for Contaminated Harbor Sediments	ppg. 197–212
<i>Michael A. Champ</i>	
The Effects of Regulating the Use of TBT-Based Antifouling Paints on TBT Contamination	ppg. 213–216
<i>Stewart M. Evans, and R. Smith</i>	
The Environment: Our Joint Responsibility	ppg. 217–222
<i>Stewart M. Evans</i>	
ONR Contracts and Grants Page	pg. 223

AUTHORS INDEX

- Abel, David pg. 73
- Akan, A. Osman pg. 1
- Ashcroft, Peter L. pg. 73
- Beacham, Thomas pg. 63
- Brancato, Mary Sue ppg. 153, 169, 177, 185
- Bruening, Ronald pg. 107
- Cardwell, Rick pg. 169
- Champ, Michael A. ppg. 63, 137, 197
- Damodaran, Nimmi pg. 153
- DeForest, David ppg. 153, 169, 177
- Destailats, Hugo pg. 107
- Evans, Stewart M. ppg. 193, 213, 217
- Felmy, John pg. 153
- Fletcher, Lyn E. pg. 27
- Ford, Katherine pg. 107
- Fox, Thomas pg. 63
- Hammons, D. pg. 185
- Harrell, Laura J. pg. 1
- Hunter, Walter pg. 107
- Johnson, David pg. 41
- Jones-Lee, Anne pg. 51
- Kim, Nam Sook pg. 119
- Kluck, Michael pg. 153
- Kura, Bhaskar ppg. 17, 77
- Lee, G. Fred pg. 51
- Lee, Soo Hyung pg. 119
- Levcun, Greg pg. 107
- Lewis, John A. pg. 27
- Lloyd, Todd pg. 107
- MacLellan, D. ppg. 177, 185
- Miller, Fred pg. 91
- Mulligan, Conrad pg. 153
- Nicholson, G.J. pg. 193
- Oh, Jae Ryoung pg. 119
- Pendleton, Mike pg. 153
- Pommerenk, Peter pg. 1
- Putnam, Mike pg. 37
- Randall, Doug pg. 95
- Salter, Jr., Joel H. pg. 135
- Schafran, Gary C. ppg. 1, 63
- Shim, Won Joon pg. 119
- Smith, R. pg. 213

Tadimalla, Raghuram.....	ppg. 17, 77
Tear, Lucinda	pg. 169
Toll, John	ppg. 153, 169
Volosin, J.....	pg. 177
Weavers, Linda	pg. 107

PREFACE

Summary of Seattle Oceans '99 Treatment of Discharges from Shipyards Panel Discussion

A closing panel discussion was scheduled for review and discussion of the papers presented by speakers at the special sessions. Participants in the panel discussion were: Stewart Evans (University of Newcastle, UK), Mike Pursley (MARAD), Joel Salter (USEPA OW), Chris Swanson (Miller Associates, CQD), Alan Mearns (NOAA, HAZMAT) and Mike Champ (ATRP Corporation). Tom Fox was unable to participate in the panel discussion, because he was previously scheduled for his daughters wedding.

The papers in this volume represent an excellent global update and state-of-the-art on the treatment of discharges from shipyards. Several papers in these Proceedings were not presented by the authors themselves, but were presented by American colleagues in attendance at the conference. Several others have been added as we learned of overseas studies and projects following Oceans '99. We wanted to publish a bibliography in this area, but have found only a sparse number of technical publications. We have ensured that most of these were referenced in this volume. Thus, the papers in this volume represent more of a global collection of the available technical literature than just those presented at the Conference. We also added the TBT Special Sessions papers to this volume, both because of their relevance and unavailability for publication with the regular Conference Proceedings.

The panel discussion, evolved into a working group from the floor of the session representing the participants on the last day of the conference. This ensured better balance and greater diversity of discussion, since half of the panel members were not speakers, but attendees.

The panel identified a series of major concerns or issues from the presented papers which, in turn, became recommendations for further consideration by any interested parties: governments (local, regional or national), the shipping industry, the shipyard industry, port and harbor authorities or non-government organizations and environmental organizations. The following is a summary of the recommendations of speakers and panel participants at the Ocean's '99 Conference.

SUMMARY AND RECOMMENDATIONS

Review of the Science Associated with the Regulation of TBT

- With regard to the peer review of the science being used in the international regulatory decision process at the International Maritime Organization (IMO), it was felt that the trend data presented for the regulated countries did not warrant at this time a global ban. However, global implementation of national regulations with necessary modifications (to meet existing environmental conditions in enclosed ports or harbors) is recommended given the trade offs to the shipping industry of increased annual costs ranging from \$ 500 million to \$ 2 billion.
- Either cooperation from existing international scientific advisory organizations or the formation of a new - special group to assist and complement the international regulatory and global decision-making processes at IMO.

Policing After Implementation of the Global Ban for TBT

- There is no non-destructive and/or inexpensive rapid method available for detecting and measuring TBT on a ship's hull after the ban is implemented.
- There is no neutral-third party-independent certification process for ship owners that is accepted as proof that their ship hulls are TBT paint free.
- There is no national or international policing system to enforce the TBT ban, or punish those that are in violation.

Removal and Disposal to TBT from Ships Hulls (2001-2008)

- There is only one advanced waste treatment system in the world that has successfully treated industrial volumes of TBT in wastewaters in accordance with shipyard operations (36 hours for washdown). The CASRM Barge Mounted System has evolved from bench type laboratory scale treatment systems to a shipyard size demonstration project.
- There is no inexpensive advanced waste treatment system or technologies available in commercial sizes that can rapidly treat million gallon quantities of TBT contaminated ship washdown or runoff wastewaters from shipyards and drydocks.
- There are no federal, industry, and/or internationally funded organizations to promote the development and/or evaluation (including certification) of advanced waste treatment technologies to treat TBT discharges from shipyards.

Promotion and Development of Alternatives to the Use of TBT

- Except for promotion by IMO, there are no federal, industry, and/or internationally funded organizations to support and fund the R&D for TBT alternatives in the marketplace.
- There are no international standard protocols or tests that can be used to assess, compare and evaluate available alternatives to TBT antifouling paints.
- There are no federal, industry, and/or internationally funded international organizations to test, evaluate, and certify available alternatives to TBT antifouling paints. The recently proposed International Marine Coatings Board (see Champ, 1998 and 1999a citations in this volume) was discussed and endorsed by the panel.

BACKGROUND

The IMO Marine Environment Protection Committee (MEPC) recommended in November 1999 that IMO, should hold a Conference in the 2000-2001 biennium to adopt a legal instrument (global treaty) to regulate the use of shipboard anti-fouling systems, in particular to phase out those containing organotins such as tributyltin (TBT). TBT paint is used to prevent the growth of marine organisms, such as barnacles, on the hulls of ships. TBT based paints are the most effective antifouling paints known. They are designed to work by continuously leaching TBT from the coating into the surface layer of water surrounding the hull. It is estimated that over 70% of the 27,000 vessel global merchant fleet is currently coated with TBT antifouling paints.

TBT is known to be extremely toxic to some marine animals. Adverse effects have been documented at concentration levels of ng/L (parts per trillion) such as shell abnormal growth deformities in oysters and imposex (sex change) in dogwhelks. Concern about the toxicity of TBT led the U.S. Congress to pass the *Organotin Paint Control Act in 1988*. Similar legislation was passed in other major maritime countries. Continued concern has led the United States to support an international ban on the use of TBT in conjunction with other nations at IMO.

Tens of thousands of port calls are made each year at U.S. ports, by ships coated with TBT paint, leaching TBT into waterways and sediments. Unfortunately, the global ban will be toothless, because at this time there are no non-destructive methods available to port and regulatory authorities to detect or measure TBT on ship hulls visiting U.S. ports or coastal waters. Absence of this technology presents problems for enforcement of the proposed ban, because large ocean-going commercial ships can be painted in shipyards in any country of the world. The current (destructive) methods for the analysis of TBT are both time-consuming (1-2 days) and expensive (\$ 500-1000/per sample).

Between 2003 and 2008, approximately 20,000 ships in global commerce today will have to be scraped to bare metal removing more TBT than in the last 40 years combined. Normally when a ship goes into the shipyard for cleaning and repainting, if it is painted with TBT, a high pressure power wash can be used to remove just the top or damaged layer(s) keeping the remaining base coats. Following the global treaty to ban the use of TBT by the International Maritime Organization (IMO) and the mandatory removal of TBT from all ships, shipyards will be faced with a major dilemma. They will have to treat large quantities of TBT wastewater as a toxic waste.

To protect the marine environment from discharges of TBT, shipyards all over the world need a new and inexpensive process to treat TBT wastewater. A project funded by the U.S. EPA and the State of Virginia has demonstrated barge mounted system technologies that can TBT remove from shipyard wastewaters to below 50 ng/L using Granular Activated Carbon (GAC) columns (Fox et al., this volume). While this method is technically effective, it is not very cost effective, because the life of the GAC columns is reduced by the high levels of dissolved organic compounds naturally present in the shipyard wastewaters.

In the U.S., the lack of an advanced technology for ship yards to inexpensively remove TBT from wastewaters, could precipitate:

- Gross violations of State TBT Water Quality Standards, and discharge permit regulations for TBT (at present only the State of Virginia has a VPDES discharge permit level of 50 ng/l); and/or
- A significant reduction of work in U.S. shipyards (which are currently a depressed business) as they loose a large volume of ship repair and repainting business over the next 10 years.

OBJECTIVES OF THE SPECIAL SESSIONS AND PROCEEDINGS

The objectives of the special sessions on the Treatment of Regulated Discharges from Shipyards and Drydocks and Organotin (TBT) at the Oceans '99 Meeting in Seattle have been to:

- Characterize waste waters from different types of shipyards, drydocks, operations (etc.);
- Review and evaluate wastewater treatment technologies currently used in shipyards;
- Promote technology transfer;
- Review policy and regulatory strategies;
- Discuss results of TBT studies and findings;
- Discuss available alternatives to TBT;
- Review R&D needs; and
- Publish in one-volume papers from the Special Sessions.

The data, information and literature associated with identifying and treating the wastewater discharges from shipyards and drydocks is mostly unpublished in the technical literature and not very available. These data can be in very gray and unpublished shipyard regulatory databases or data files or summary water quality regulatory monthly compliance records. Such data files are kept by individual shipyards for review by regulatory officials and are never published. If this data were collected for compliance purposes, there could be a summary of tabulated or plotted data. If discharge data and information were collected as part of a R&D Project, there may be a technical report available (application or cleaning costs, or evaluation of application or cleaning technologies, etc.).

ACKNOWLEDGEMENTS

The work relates to Department of Navy Grant N00014-99-1-0811, issued by the Office of Naval Research) and the Department of Environmental Quality of the Commonwealth of Virginia (Contract No. 93000048). Both are to be acknowledged for their support for these Special Sessions on the "Treatment of Regulated Discharges from Shipyards and Drydocks." We would also like to thank Vivian Holland of Holland Publications, 1782 Solana Glen, Escondido, CA., Tel. (760) 743-8486, <vholland@adnc.com>, for serving as the Technical Production Manager for the publication of these Proceedings. The opinions expressed in this volume may not reflect those of the U.S. Government, NOAA, EPA, the U.S. Navy or the Commonwealth of Virginia, nor does mention of trade names or commercial products constitute endorsement or recommendation for use. The United States Government and the Commonwealth of Virginia have a royalty-free license throughout the world in all copyrightable material contained herein.

Session Co-Chairmen and Proceedings Volume Editors:

Michael A. Champ
President & CEO
ATRP Corporation
P.O. Box 22042
7000 Vagabond Drive
Falls Church, Virginia 22042
Tel. (703) 237-0505
Fax (703) 241-1278
machamp@aol.com.

Thomas J. Fox
Executive Director
Center for Applied Ship
Repair and Maintenance, Inc.
222 E. Main Street
Norfolk, Virginia 23510
Tel. (757) 622-2137
Fax (757) 622-2490
casrm@infi.net.

Alan J. Mearns
Senior Staff Scientist
Hazardous Materials Response
Division
National Oceanic and
Atmospheric Administration
7600 Sand Point Way, N.E.
Seattle, Washington 98115
Tel. (206) 526-6336
Fax (206) 526-6329
Alan_Mearns@hazmat.noaa.gov.

SIMULATION OF STORMWATER RUNOFF FROM MARINE DRYDOCKS

**Osman Akan¹, Gary C. Schafran², Peter Pommerenk³,
and Laura J. Harrell⁴**

Abstract

Stormwater runoff from a floating marine drydock can be a major source of pollution for the waterway in which the drydock is located. Significant amounts of pollutants build up over drydock surface due to intensive industrial activity. During periods of rainfall these pollutants can be washed off and quickly transported into the receiving water. A mathematical model has been developed in this study to simulate the quantity and quality of stormwater runoff from marine drydocks. The mathematical model is based on the two-dimensional kinematic-wave and convective transport equations for total suspended solids. An empirical formula is used to model the wash-off process. An implicit finite difference scheme is employed to solve the governing equations of the model numerically. Also, the quantity and quality of stormwater runoff from a private drydock has been monitored under actual rainfall conditions. The samples collected were analyzed in the laboratory to determine the pollutant loadings of the runoff. This data was used to test and verify the mathematical model.

Keywords: Drydock, Stormwater, Runoff, Pollutant, Total Suspended Solids, Kinematic-wave

INTRODUCTION

Discharges from non-point sources such as agricultural and urban stormwater runoff have recently been recognized as major causes of pollution of surface waters. Contaminants from motor vehicles, construction activities, chemicals used in agriculture, atmospheric fallout, animal feces, solid waste litter and other anthropogenic sources build up on the land surface and may be mobilized by rainwater. Stormwater runoff from urban areas mobilizes substantial amounts of pollutants, and their origin can often not clearly be defined. In the past large scale studies have been conducted to investigate urban stormwater runoff. Interestingly, little attention has been

¹ Professor, Department of Civil. and Environmental. Engineering, Old Dominion University, Norfolk, VA23529-0241, Tel. (757) 683-3753, Fax (757) 683-5354, E-Mail: oakan@odu.edu

² Associate Professor, Department of Civil. and Environmental. Engineering, Old Dominion University, Norfolk, VA23529-0241, Tel. (757) 683-3753, Fax (757) 683-5354, E-Mail: gschafra@odu.edu

³ Graduate Research Assistant, Department of Civil. and Environmental. Engineering, Old Dominion University, Norfolk, VA23529-0241, Tel. (757) 683-3753, Fax (757) 683-5354, E-Mail: ppommern@cee.odu.edu

⁴ Assistant Professor, Department of Civil and Environmental Engineering, Old Dominion University, Norfolk, VA23529-0241, Tel. (757) 683-3753 Fax (757) 683-5354, E-Mail: lharrel@odu.edu

paid to stormwater runoff from shipyard drydocks and its impact on the adjacent waters in the recent literature, although water pollution is a serious problem in coastal areas (U.S.E.P.A., 1996).

Shipyard (floating) drydocks are sites of intensive industrial activity in the construction, repair, and maintenance of ships. Because of the location of floating drydocks in a waterway and their regular submersion below the water surface, materials located on the surface of a drydock can potentially be washed into the surface water by solubilization or transport in particulate form. While shipyards are careful to clean drydock surfaces prior to submersion, there is the potential for wash-off of materials from the drydock surface during periods of rainfall. Runoff is generally quickly generated because the drydock surface is impermeable and the runoff volume can be significant given the area of drydocks can exceed several acres.

The potential sources of pollutants in the stormwater runoff are strongly dependent on the activities performed on a drydock. Removing and applying paint to a ship's hull is an important and common drydock activity that can lead to the accumulation of toxic metals on a drydock surface. The construction of new ships and repair of older vessels both require extensive preparation of steel surfaces and abrasive (grit) blasting is a widely used method to pretreat a ship superstructure. It basically involves the impingement of grit with high-pressure air to remove paint, rust, and contaminant materials that adhere to the surface. Other methods for surface preparation include pressure washing and hydroblasting before metal primers and antifoulants are applied.

Both spent blasting grit and marine paints contain toxic materials, which may reach the receiving water. During the period before a storm event airborne particles from stack gases and exhaust fumes may also build up on the drydock surface and some contaminants can also originate from motor vehicles and other machinery operated on the drydock. The prediction of pollutants in stormwater runoff from drydocks, especially heavy metals, requires knowledge of the composition of the materials used during ship maintenance, the pattern of accumulation on the drydock surface, and the mechanism of mobilization during a rainfall event.

Like other major industries, shipyards have to comply with local and federal toxic effluent limitations, as required by the National Pollutant Discharge Elimination System (NPDES). Although the toxicity of effluents from drydocks is being assessed for compliance purposes, little research has been conducted to investigate the composition and transport mechanisms of pollutants in runoff from shipyard drydocks. The chemical and physical processes which control the fate and transport of trace metals in rainfall runoff from drydocks need to be examined in order to develop effective measures to prevent negative impacts on the receiving water.

As part of a comprehensive study of drydock runoff a mathematical model was developed that can be used to simulate the runoff quantity and quality from a shipyard drydock. Hydrological and water quality data were collected from a private drydock during several rain events and were used to verify the mathematical model. The total suspended solids concentration was chosen as a representative parameter to characterize the quality of the drydock runoff in the mathematical model, because it is believed that toxic metals (i.e. copper and lead) are mobilized in proportion to the overall particulate matter (Pommerenk, 1996).

DESCRIPTION OF THE MATHEMATICAL MODEL

The stormwater runoff model consists of two components. The first component is for modeling the surface runoff rates from a drydock. The second component is for modeling the washoff and transport of particulate pollutants by the surface runoff.

Runoff Component

The runoff over the surface of a drydock during and following a rain event is represented by the two-dimensional kinematic-wave equations. The equation of continuity is written as

$$\frac{\partial y}{\partial t} + \frac{\partial q_x}{\partial x} + \frac{\partial q_y}{\partial y} = r \quad (1)$$

where:

- y = flow depth
- t = time
- q_x = flow rate in x-direction per unit width
- q_y = flow rate in y-direction per unit width
- x, y = flow directions
- r = rate of rainfall

The momentum equations in the x and y directions are approximated by the respective kinematic relationships, as:

$$\frac{n^2 u_x \sqrt{u_x^2 + u_y^2}}{c_0^2 y^{4/3}} = S_x \quad (2)$$

and:

$$\frac{n^2 u_y \sqrt{u_x^2 + u_y^2}}{c_0^2 y^{4/3}} = S_y \quad (3)$$

where:

- n = Manning roughness factor

- $c_0 = 1.49 \text{ ft}^{1/3}/\text{sec} = 1.0 \text{ m}^{1/3}/\text{sec}$
 $u_x =$ velocity in the x-direction
 $u_y =$ velocity in the y-direction
 $S_x =$ dock surface slope in x-direction
 $S_y =$ dock surface slope in y-direction

Noting that:

$$q_x = y u_x \quad (4)$$

$$q_y = y u_y \quad (5)$$

Eqs. 2 and 3 can be manipulated mathematically to obtain

$$u_x = \alpha_x y^{2/3} \quad (6)$$

$$u_y = \alpha_y y^{2/3} \quad (7)$$

$$q_x = \alpha_x y^{5/3} \quad (8)$$

$$q_y = \alpha_y y^{5/3} \quad (9)$$

where:

$$\alpha_x = \frac{c_0}{n} \frac{S_x}{(S_x^2 + S_y^2)^{1/4}} \quad (10)$$

and:

$$\alpha_y = \frac{c_0}{n} \frac{S_y}{(S_x^2 + S_y^2)^{1/4}} \quad (11)$$

Substituting Eqs. 8 and 9 into Eq. 1, we obtain:

$$\frac{\partial y}{\partial t} + \frac{\partial}{\partial x} (\alpha_x y^{5/3}) + \frac{\partial}{\partial y} (\alpha_y y^{5/3}) = r \quad (12)$$

Equation 12 describes the spatial and temporal variation of the flow depth, y , over the drydock surface. This is a nonlinear partial differential equation for which no analytical solutions are available. Therefore, a finite difference scheme is adopted to solve Eq. 12 numerically to find y at specified locations over the drydock and at specified times. Once the flow depth is found, Eqs. 6 to 9 are used to determine the velocities and flow rates. In the solution of Eq.12 the appropriate boundary conditions are incorporated by setting \bullet_y or \bullet_x equal to zero at the side walls.

Particulate Pollutant Transport

The transport capacity of the runoff over a drydock surface is evaluated using the Low (1989) formula. Govers (1993) evaluated the performance of a number of similar formulae and found that the Low formula was satisfactory. The formula is written for the general flow direction in any consistent unit system as

$$q_s = \frac{6.42}{(s - 1)^{0.5}} (Y - Y_{cr}) D S^{0.6} u_s \quad (13)$$

where:

- q_s = solids discharge per unit width
- s = \bullet_s / \bullet
- Y = dimensionless shear stress = $\bullet / \bullet_s' D$
- Y_{cr} = critical dimensionless shear stress = $\bullet_{cr} / \bullet_s' D$
- D = grain diameter
- S = average surface slope
- u = resultant velocity
- \bullet_s = density of particles
- \bullet = density of water
- \bullet_s' = submerged specific weight = $g (\bullet_s - \bullet)$

- g = gravitational acceleration
- = shear stress = • g y S
- _{cr} = critical shear stress

The Low formula is based on the rationale that the particulate pollutants are picked up from the surface due to the shear forces. To account for the impact of raindrops, an empirical formula is adopted in the model. Over a time increment of • t, the particulate pollutant splash from an area (• x • y) is

$$s_p = a_3 r_0^{0.3} \left[a_1 \Delta t r_0 + a_2 \Delta t r_0 \log (43200 r_0) \right] \frac{\Delta x \Delta y}{\Delta t} \quad (14)$$

where:

- s_p = splash (lbs/sec)
- r₀ = rate of rainfall (ft/sec)
- t = time increment (sec)
- a₁, a₂, a₃ = empirical constants.
- x, • y = side lengths of reference area (ft)

This formulation is based on the kinetic energy of raindrops, and it has the same form as the formula proposed by Bubbenzer and Jones (1971) and used previously by Akan and Ezen (1982) successfully. The empirical constants used in this model are a₁= 7363, a₂= 2661, a₃= 0.00055. Also, •_{cr}= 0.02 lbs/ft².

Components of the solids discharge in the x- and y-directions are determined by distributing q_s and s_p according to the flow rates as

$$Q_{s,x} = q_s \frac{q_x \Delta y}{(q_x^2 + q_y^2)^{1/2}} + \frac{s_p}{\left(1 + \frac{q_y \Delta x}{q_x \Delta y} \right)} \quad (15)$$

and

$$Q_{s y} = q_s \frac{q_y \Delta x}{(q_x^2 + q_y^2)^{1/2}} + \frac{s_p}{\left(1 + \frac{q_x \Delta y}{q_y \Delta x}\right)} \quad (16)$$

where:

Q_{sx} = solids discharge in the x-direction (lbs/sec) per length • y

Q_{sy} = solids discharge in the y-direction (lbs/sec) per length • x

The average concentration, c_s , is determined as

$$c_s = \frac{\left[\left(\frac{Q_{sx}}{\Delta y} \right)^2 + \left(\frac{Q_{sy}}{\Delta x} \right)^2 \right]^{1/2}}{(q_x^2 + q_y^2)^{1/2}} \quad (17)$$

The conservation of mass equation is now written as

$$\frac{\partial (c_s y)}{\partial t} + \frac{\partial (c_s q_x)}{\partial x} + \frac{\partial (c_s q_y)}{\partial y} = W_s \quad (18)$$

where W_s = mass of solids picked up by the flow per unit area per unit time. In Eq. 18, q_x and q_y are known from the solution of the flow equations, and c_s is known from Eqs. 15 to 17. We can therefore write Eq. 18 in finite difference form and solve it for W_s .

Positive values of W_s will represent particulate pollutant pick-up by the runoff, and the negative values represent deposition over the drydock surface. If W_s is positive, then we must have $W_s < (P_s / \Delta t)$ for the formulation to be valid where P_s = mass of particular pollutant present on the drydock surface per unit area prior to the time period Δt . If $W_s > (P_s / \Delta t)$, the pollutant pick-up rate predicted by Eq. 18 can not be sustained. In that event the model sets $W_s = P_s / \Delta t$ and corrects the values of the pollutant concentration, c_s , by solving Eq. 18 in finite difference form for c_s . Obviously, it is possible to have $P_s = 0$.

Finite Difference Equations

Analytical solutions are not available for the governing equations of the mathematical model. Therefore, finite difference methods are used to solve these equations numerically.

With reference to the computational grid shown in Fig. 1, Eq. 12 is written for cell (i,j) in finite difference form as:

$$\frac{y_{i,j} - y_{i,j}^o}{\Delta t} + \frac{\left(\alpha_x y_{i,j}^{5/3} \right)_{k,j} - \left(\alpha_x y_{i-1,j}^{5/3} \right)_{k-1,j}}{\Delta x} + \frac{\left(\alpha_y y_{i,j}^{5/3} \right)_{k,j} - \left(\alpha_y y_{i,j-1}^{5/3} \right)_{k,j-1}}{\Delta y} = r \quad (19)$$

where:

- t = time increment
- x, • y = side lengths of a computational cell
- y = depth sought at the end of time period • t
- y^o = known depth at the beginning of time period • t.

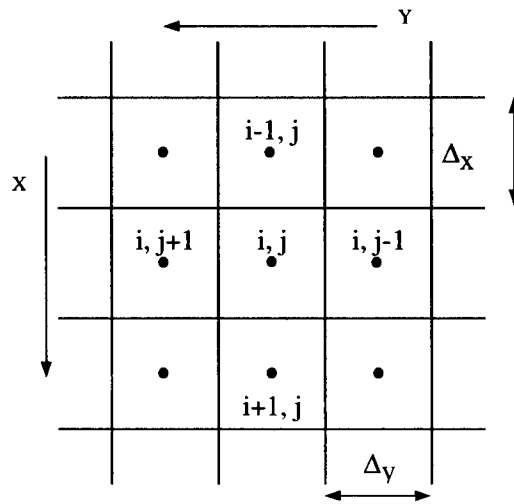

Figure 1. Finite Difference Grid for the Drydock.

For any time step of computation, Eq. 19 is written for each of the (NCOL x NROW) cells where NCOL = total number of columns and NROW = total number of rows. This will result in (NCOL x NROW) simultaneous algebraic equations containing the same number of unknowns, $y_{i,j}$, with $1, 2, \dots, NROW$ and $j = 1, 2, \dots, NCOL$. The y^o values are known from the initial conditions for the first time step. For the subsequent time steps, the y^o values will be known from the previous time step results.

Equation 19 is solved by using the Newton method for each cell starting on the first row with cell (1,1). Then the cells on the subsequent rows are considered. It should be pointed out that at the time a cell (i,j) is considered, the values of $y_{i-1,j}$ and $y_{i,j-1}$ are known either from the boundary conditions, or from the results of the calculations already completed for the other cells.

Therefore, in Eq. 19 the only unknown will be $y_{i,j}$. Once the flow depths are calculated in all the cells, the velocities and the flow rates are found using Eqs. 6 to 9.

The particulate pollutant transport equation is written in finite difference form as

$$\frac{(c_s y)_{i,j} - (c_s y)_{i,j}^{\Delta t}}{\Delta t} + \frac{(c_s q_x)_{i,j} - (c_s q_x)_{i-1,j}}{\Delta x} + \frac{(c_s q_y)_{i,j} - (c_s q_y)_{i,j-1}}{\Delta y} = (W_s)_{i,j} \quad (20)$$

In this equation c_s values are known from Eq. 17 and y , q_x , and q_y values are known from the results of the flow model. Therefore, W_s can be calculated explicitly for each cell. However, as discussed previously, if W_s so calculated turns out to be greater than $P_s / \Delta t$ for a cell, we set $W_s = P_s / \Delta t$ for that cell. Then we solve Eq. 20 for c_s using the Newton method to recalculate the particulate pollutant concentrations in the flow.

MONITORING AND CHARACTERIZATION OF DRYDOCK RAINFALL RUNOFF

Rain-generated runoff was sampled at a private drydock in Norfolk, Virginia. The drydock was a floating drydock, 950 feet in length, 192 feet wide with an impervious steel deck and approximately 40 feet high wing walls at the starboard and port sides as displayed in Fig 2. The deck is sloped from the centerline to the wingwalls, and the drydock is generally inclined to cause runoff to flow to the stern.

Once in the drydock, the major activities on the ship include pressure washing, hydroblasting, sand (grit-) blasting, hull painting, and machine repair. To prevent the paint spray to be transported by winds off the drydock, tarps typically cover the top of the drydock, as shown in Fig. 2. Hay bales, placed as shown in Fig. 2, serve as a control measure to capture particulate matter, especially sandblasting grit, that might otherwise be washed into the river.

Equipment and Setup

Stormwater runoff from the port side of the drydock was collected in a flume, made from stainless steel, which was installed at the stern of the drydock. The flume consisted of a rectangular section, which was closed on one end, and a short, converging section welded to the other end, where the water discharged to the river as shown in Fig. 3. This structure not only served as a flow-through trough, from which samples were collected, but also as the *primary measuring device* for determining the water discharge rate to the river. The shape and dimensions of the flume conformed to an H-type flume (Grant, 1992). The depth-discharge relationship for this type of flume was programmed into the flowmeter to calculate the flow of water through the flume.

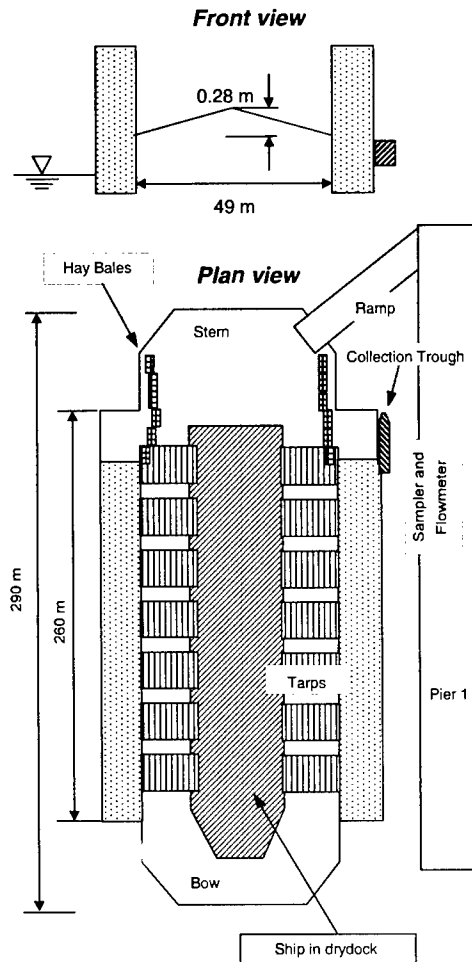

Figure 2. Drydock Schematic.

The automatic sampler contained 24 1000 mL polypropylene bottles in its air-tight base section. Rainfall at the drydock was measured with a tipping bucket rain gauge, which was mounted 30 yards away from the collection trough. The rain gauge was capable of measuring 0.01 - 22 inches of rain per hour and sent an electrical signal to the nearby flowmeter for every 0.01 inches of rain that the rain gauge received. The flowmeter was stored along with the automatic sampler in a wooden box on the pier next to the collection trough and served the purposes of storing the rainfall data in two-minute time increments, measuring the water elevation in the trough and converting it to flow and storing the data in memory, and triggering the automatic sampler, if preset conditions were met. Upon triggering (turning on) by the flowmeter the sampler purged the vinyl suction line, which was submerged in the trough, and then pumped approximately one

liter of runoff into a sample bottle.

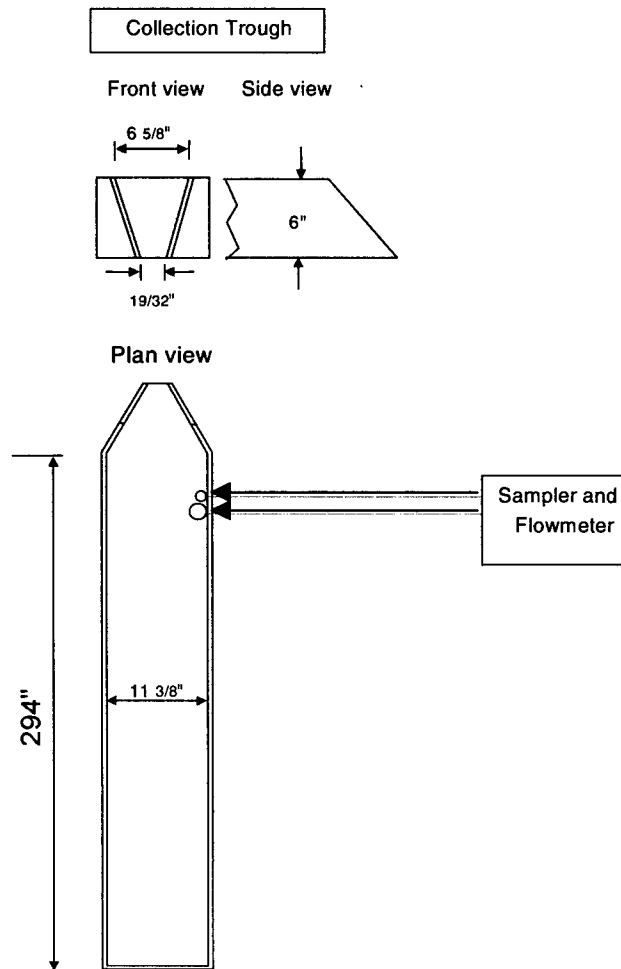

Figure 3. Collection Trough and Flow Measurement Location

The flowmeter was programmed to start the sampling sequence, when the following two conditions were met: The rainfall depth exceeded 0.01 inches within a 15 minute period, and the liquid level in the trough had to be greater than 0.5 inches. This ensured that the sampler was only triggered by rainfall and not by "runoff" from other sources; for example runoff generated by the drainage of ballast water from a ship in the drydock.

After the immediate collection of the first sample, the flowmeter triggered the automatic sampler to take one sample out of the trough for every 400 gallons of runoff, until either the 24 bottles were filled, or the sampling sequence was stopped manually, because the runoff event subsided

to negligible amounts. The flowmeter recorded the date and time each sample was collected so that the chemical characteristics of each sample could be compared to the time flow conditions during an event.

Laboratory Analyses

Total suspended solids concentrations were determined gravimetrically following APHA (1995) standard methods. Glass fiber filter disks were prewashed with deionized water and dried at 103°C for one hour. After cooling in a desiccator, the filter discs were transferred to clean aluminum weighing dishes and weighed on an electronic balance before analysis. A 20ml aliquot of the well-mixed sample was filtered using a vacuum filtration device. The filter disc was placed back into the weighing dish and dried at 103°C. The filtrate was transferred from the suction flask to another preweighed aluminum dish and also allowed to dry for 24 hours. After drying and cooling in a desiccator, the dishes were weighed and the total dissolved and total suspended solids concentrations were calculated as the difference in weight divided by the volume of sample.

VERIFICATION OF THE MODEL

The drydock stormwater runoff quantity and water quality data collected during four rainfall events were used in this study to verify the mathematical model. The absence of hay bayles blocking the runoff from the drydock during these events was the major factor for the selection of these events for verification purposes. When present, the hay bayles alter the hydraulics of the stormwater runoff significantly invalidating the formulations used in the model. The four rainfall events used for verification are of November 7 and 11, 1995, and January 27 and March 1, 1996.

The computational grid used in the calibration runs is shown schematically in Fig. 4. This represents only one half of the drydock. Taking advantage of the symmetry, only one half of the drydock was investigated in this study. The computational grid consists of five columns and 38 rows. Each computational cell is 25 ft by 16 ft. The mathematical model calculates the flow depths and pollutant concentrations at the centroids of the cells. It also calculates the runoff and pollutant discharges entering and leaving the cells in the x- and y-directions. The lateral slope S_y is constant and is equal to 0.01146. The longitudinal slope, S_x , can vary, but it is normally set at 0.00267. The sampling station was at the edge of cell (34,5). Some of the cells are occupied by a ship. The total number of these cells depends on the size of the ship. Likewise, some of the cells are covered by tarps the extent of which can vary.

The waste load on the drydock deck is comprised of blasting grit, spent paint chips, and other debris. A sieve analysis was performed on a sample of spent blasting material. The sample was dried and sieved to separate size fractions. Then the density were found for each fraction (Fenn, 1996). This analysis resulted in a representative particle diameter of 0.0036 ft and a density of 6.2 slug/ft³, which were used as input for calibration runs.

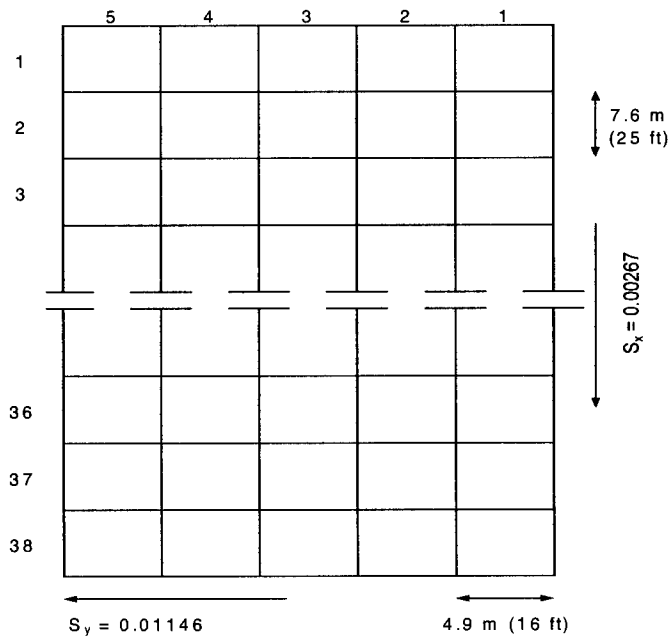

Figure 4. Computational Grid for Drydock.

Not all the model input variables were available for the verification runs. parameters. For instance the amount of rainfall intercepted and diverted by the tarps or a ship could not be determined directly. Therefore, these values were adjusted so that the measured and calculated total runoff would be nearly equal. Likewise, modeling the pollutant build-up over a drydock surface was not part of this study, and the initial amount of pollutants available on a drydock prior to a rain event could not be measured directly. Therefore, the initial amounts were adjusted so that total amounts of measured and modeled TSS were nearly the same. Table 1 summarizes the conditions simulated in the model verification runs.

Table 1. Drydock Conditions for Model Simulations.

Date of Event		Nov. 7, 1995	Nov. 11, 1995	Jan. 27, 1996	Mar. 1, 1996
Rain Duration [min]		500	120	264	556
Total Rainfall [in]		0.75	0.43	0.51	0.44
Tarp	Columns	N/A	N/A	1 to 5	1 to 5
	Rows	N/A	N/A	1 to 25	1 to 34
Ship Location	Columns	1 to 2	1 to 2	N/A	N/A
	Rows	1 to 34	1 to 25	N/A	N/A
Total Nonsoluble Solids Initially Available [lbs]		40	5.5	10	3.6
Rain Intercepted by Tarps %		N/A	N/A	43	43
Rain Intercepted by Ship %		80	55	N/A	N/A

Figure 5 displays a comparison of modeled and measured values of cumulative stormwater runoff rates from the drydock. Likewise, Fig. 6 displays a comparison of modeled and measured cumulative TSS discharge. The agreement appears to be reasonably good. Obviously, without measured values of the amount of the rainfall intercepted by the tarps and the initial distribution of pollutants over the drydock, the model can not be fully verified. However, the agreement between the measured and modeled values are encouraging.

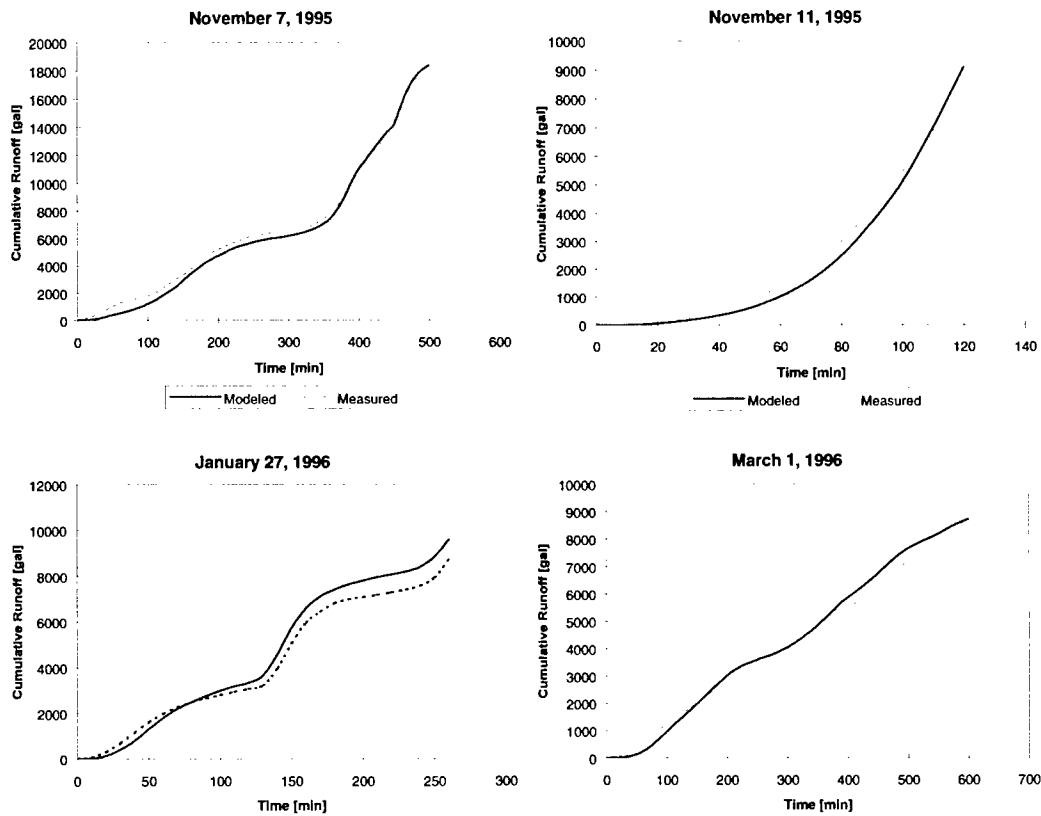

Figure 5. Modeled and Measured Cumulative Runoff for the Indicated Storm Events.

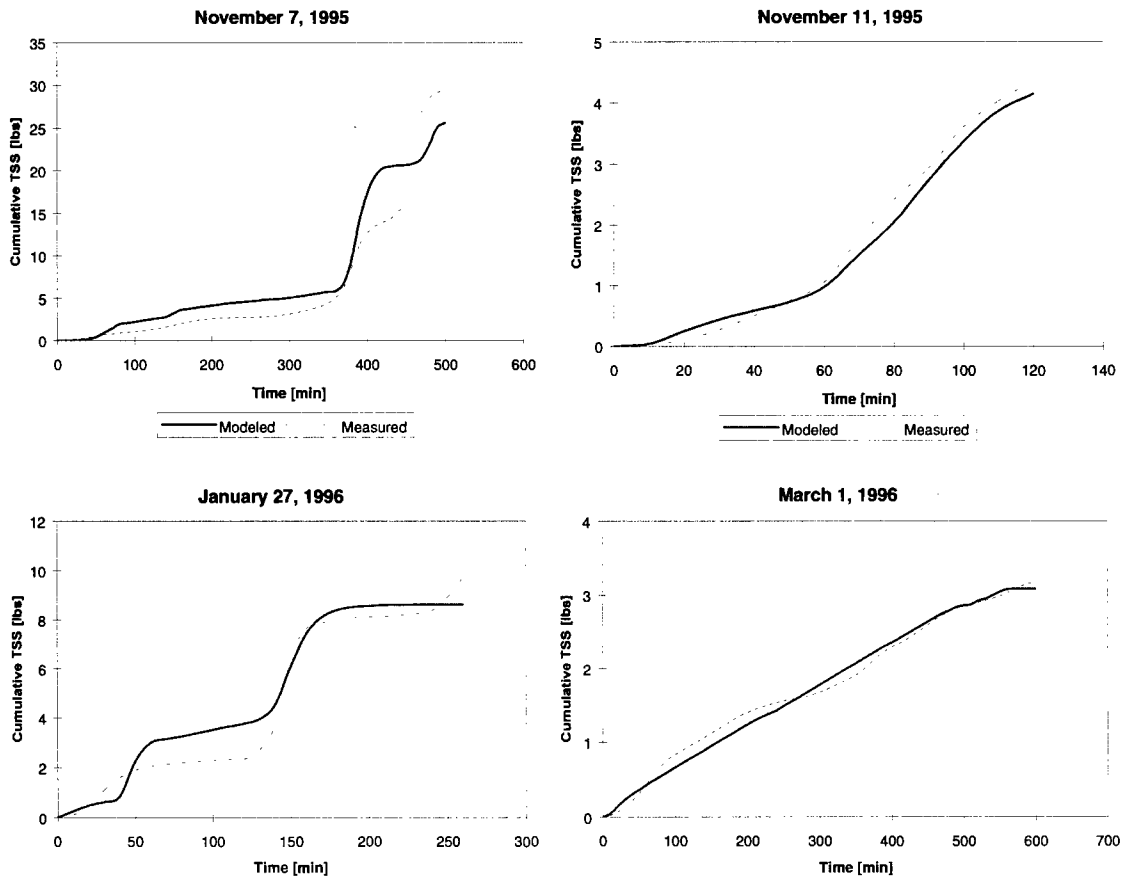

Figure 6. Modeled and Measured Cumulative TSS Washoff for the Indicated Storm Events.

SUMMARY AND CONCLUSIONS

A mathematical model has been developed for characterization of stormwater runoff from marine drydocks. The model has been tested for the quantity of runoff and for TSS loadings for several actual rainfall events monitored. The model results were found to be encouraging.

TSS is the only constituent considered in the mathematical model presented. However, a large number of rain-generated drydock runoff samples were collected and analyzed in the laboratory during the course of this study. Based on these analyses additional relationships are now being developed between the concentrations of total suspended solids and other constituents. These relationships will be published in the near future. With the addition of such relationships the usability of the mathematical model will increase significantly.

A major difficulty in the application of physically based models for drydock runoff is the description of the initial condition of the drydock surface prior to a storm. One needs to know

the initial amounts and distribution of pollutants over the drydock surface available for washoff. This information in a real life situation is very difficult to gather. Perhaps, empirical relationships can be developed to determine the surface conditions of a drydock as a function of the activities taking place prior to a storm. One needs to point out that this would be a rather difficult task because of the wide variations in the drydock activities. Also, monitoring the pollutant build up over a drydock surface without interfering with the drydock activities may become challenging.

ACKNOWLEDGEMENTS

This study was funded by Center for Advanced Ship Repair and Maintenance (CASRM) through grants from Advanced Research Project Agency (ARPA), and the Virginia Center for Innovative Technology, and with support from the City of Norfolk and Old Dominion University.

APPENDIX- REFERENCES

Akan, A. O., and Ezen, S. C. (1982). "Mathematical Simulation of Erosion on Graded Terraces," Recent Developments on the Explanation and Prediction of Erosion and Sediment Yield, IAHS Publication No. 137, pp. 221-227.

APHA (1995) Standard Methods for the Examination of Water and Wastewater, A.D. Eaton, L.S. Clesceri, A.E. Greenberg, Eds. American Public Health Association, Washington, D.C. 19th Edition.

Bubbenzer, G. D., and Jones, B. A. (1971). "Drop Size and Impact Velocity Effects on the Detachment of Soils under Simulated Rainfall," Trans. Am. Soc. Agric. Engrs., Vol. 14, pp. 625-628.

Fenn, T. O. (1996). A Receiving Water Quality Model for Dissolved Metal Runoff from a Floating Drydock. Master's Thesis, Department of Civil and Environmental Engineering, Old Dominion University, Norfolk, Virginia.

Govers, G. (1993). "Evaluation of Transporting Capacity Formulae for Overland Flow," Hydraulics and Erosion Mechanics, Chapman and Hill, New York, N.Y., pp. 243-273.

Grant, D. M. (1992). ISCO Open Channel Flow Measurement Handbook, Third edition, Isco, Lincoln, Nebraska. Law, H. S. (1989). "Effect of Sediment Density on Bed Transport," Journal of Hydraulic Engineering, ASCE, Vol. 115, pp. 124-128.

Pommerenk, P. (1996). Characterization of Rainfall Runoff From a Shipyard Drydock. Master's Thesis, Department of Civil and Environmental Engineering, Old Dominion University, Norfolk, Virginia.

U.S. Environmental Protection Agency (1996, January). Coastal Management Measures Guidance Fact Sheet. <http://www.epa.gov/OWOW/NPS/manual.html>

Characterization of Shipyard Wastewater Streams

Bhaskar Kura¹ and Raghuram Tadimalla²

ABSTRACT

More than 400 shipyards in the United States are involved in construction and repair of the ships and generate significant quantities of wastewater annually. Characterization of wastewater streams helps in segregation and subsequent handling of waste streams. This paper delineates various processes/operations in the shipyard that generate wastewater and gives the type of pollutants that may be present in those operations based on the method(s) employed. Surface preparation, metal plating and surface finishing, welding and metal cutting, machining and metal working, solvent cleaning and degreasing, and vessel cleaning operations constitute major sources for process wastewater from the shipyard. Wastewater analysis is required to know the strength of the pollutants in the wastewater stream. The pollutants present may be biochemical oxygen demand (BOD), total suspended solids (TSS), phenol, oil & grease, and some heavy metals. Once the constituents are known, segregation and employment of pollution prevention options such as source reduction, reuse and recycling, and treatment can be utilized to bring the strength of the wastewater stream below the discharge standards thus making it safe for aquatic life.

INTRODUCTION

The United States has over 400 shipyards involved in construction and repair of ships. Medium to large size shipyards generate as high as seven million gallons of wastewater annually. This quantity does not include sanitary wastes and stormwater. Such an enormous quantity calls for efficient management of wastewater in a way that meets the environmental standards,

compliance and protection of the aquatic life. Efficient management of the shipyard

wastewater requires understanding of the pollutants present and their concentrations. Most of the management techniques like source reduction, waste minimization, control, treatment etc. can be effectively utilized once the composition of the waste stream is known. Therefore, characterization of wastewater is of prime importance. Characterization of wastewater not only helps in the understanding of the composition of the waste streams and the associated strengths but also helps in ways of implementing the pollution prevention options apart from reduction in costs.

Operations in the shipbuilding and repair industry are of large scale, and complex, and these activities generate significant amounts of multimedia emissions (solid, liquid, and air) but this paper focuses on wastewater emission sources. Major shipyard operations that generate wastes/pollutants include surface preparation, metal plating and surface finishing, solvent cleaning and degreasing, machining and metalworking, and vessel cleaning.

The characterization of wastewater is based on the process knowledge by looking into the raw materials going into the processes and also the product coming out from the process apart from analysis of the waste stream. The pollutants that come across in the shipbuilding industry have been described in the following sections depending on the processes. A brief explanation of the processes have been given for better understanding of the wastes that generate from them.

SURFACE PREPARATION^{1,2,4,5,6,7}

State-of-the-art protective coatings, designed to give long term service life in adverse

¹ Associate Director of Maritime Environmental Resources and Information Center (MERIC), Associate Professor of Civil & Environmental Engineering, University of New Orleans, University of New Orleans.

² Research Assistant, Department of Civil & Environmental Engineering, University of New Orleans.

environments, require a substrate which is free of rust, mill scale, paint, and contaminants and has a surface profile to promote good adhesion. To achieve this condition, for both new steels and previously painted or corroded steels, it requires a mechanical or other erosion process to remove the contamination/surface layers and expose the bare steel substrate. Various methods are available to prepare metal surfaces for painting. The choice of the method to be used is based on several factors such as (1) whether the surface is painted or covered with rust scale, (2) which surface characteristics are required by the paint that is to be applied, (3) the size and shape of the surface to be prepared, and (4) the type of metal involved. Based on these factors, a suitable surface preparation method is employed. Some of the surface preparation techniques are given below owing to their potential to generate wastewater.

Wet Abrasive Blasting

Water has also been used in several forms for removing surface layers from steel. Water can be used by itself or in combination with abrasives or cleaning agents, and cleans by a combination of mechanical force and by dissolving or emulsifying contaminant materials. Wet abrasive blasting can be divided into two broad categories, air abrasive blasting with water addition, and water blasting with abrasive addition. One of the earliest methods developed was the water development process or water curtain method which projects a cone of water around the stream of air and abrasive as it leaves the nozzle. A simple water ring adaptor fits around the blasting hose nozzle is reported to reduce the airborne dust by about 50-75%. It has a minimal effect on the cleaning rate because the water does not mix with the abrasive. In the second type of wet abrasive blasting, the water is added to the abrasive just before it reaches the nozzle. Both these systems may use moderate pressures. Wet abrasive blasting can be used in most instances where dry abrasive blasting is used.

Hydroblasting

Evidence has shown that coatings applied on surfaces contaminated with soluble salts over a certain concentrations exhibit diminished performance. The new hydroblasting technique opens the possibility to clean coated and uncoated metal surfaces without the addition of

solid abrasives. This technique virtually eliminates the problems of hidden local corrosion cells. The primary application of this technique will be for an older surface which has been rusted in saline environment rather than new steel. Instead of propelling a solid material as in abrasive blasting, hydroblasting entails the use of a cavitating high pressure water jet to remove rust scales and paints. These systems may use pressures as high as 50,000 psig⁴(ultra high pressure washing). Hydroblasting can be used in most instances where abrasive blasting is used. Further, it can be used to remove scales and deposits from heat exchangers and can also be used to remove rubber lining. However, this method is not as efficient and cost effective as the abrasive blasting^{2,4}. The major problem associated with this type of blasting is flash rusting which can be solved by using inhibitors.

Chemical Stripping

Although grit blasting is probably the most effective method of removing marine growth and hull coatings, some surfaces, such as fiberglass, aluminum, or delicate steel parts, may require an alternative method⁴. Chemical strippers, such as methylene chloride-based solutions or caustic solutions, may be the most applicable. If properly ventilated, organic methylene chloride solutions give effective results in cleaning coated parts. Many times the surface preparation process begins with solvent cleaning to remove oil, grease, dirt, and other organic compounds. Inorganic compounds such as chlorides, sulfates, weld, flux, and mill scales are not removed by cleaning with organic solvents.

Small parts may be immersed in dip tanks containing a stripping solution. The parts must then be rinsed to remove the stripping agent. This process can often produce a large amount of contaminated rinse water. Some reduction in drag-out of the stripping agent can be reduced by allowing the parts to drain above the dip tank for a longer period of time.

Inorganic strippers, usually caustic soda solutions, can be used as a substitute to organic strippers in cleaning non-coated parts. It is very important that residues from alkaline solutions do not remain on the surface after cleansing. The major problems associated with inorganic strippers are the waste stripper being hazardous, and flash rusting of non-coated

parts. However, it is much easier to treat the waste on-site by neutralization and filtration before disposal into a sewer. The local regulatory authorities may require permit for this type of disposal. Table 1 lists surface preparation using chemical methods, materials used and pollutants expected in wastewater streams³.

Wastes

The wastewater generated from the surface preparation process is from the above mentioned techniques. In case of wet blasting and hydroblasting, the wastewater consists of waste sludge with spent abrasive, paint chips, and surface contaminants. The wastewater from chemical stripping may consist of used organic solvents or caustic solutions depending on the type of stripper used apart from the surface contaminants.

METAL PLATING AND SURFACE FINISHING^{2,3,4,5,6}

Metal plating and surface treatments are used in shipyards to alter the surface properties of the metal in order to increase corrosion or abrasion resistance, and/or improve electrical conductivity⁴. Metal plating operations can be categorized into electroplating and electroless plating processes. In electroplating, the metal surface acts as the cathode when electric current is passed through the solution containing metallic ions and forms an electrochemical cell. Ferrous and nonferrous objects are generally coated with aluminum, brass, bronze, cadmium, copper, iron, lead, nickel, zinc, gold, platinum, and silver.

Electroless plating uses similar steps as in electroplating, but involves the deposition of metal on a metallic or nonmetallic surface without the use of external electrical energy. Electropolishing is a similar process, different only in that the metal surface acts as an anode. Instead of deposition onto the surface of the object, a thin layer dissolves, leaving a bright, polished surface. Surface treatment includes, (1) chemical and electrochemical conversion, (2) case hardening, (3) metallic coating, and (4) chemical coatings⁴. Most surface treatment processes are completed in three basic steps, (1) surface cleaning and preparation, (2) modification, and (3) rinsing and finishing.

Chemical and Electrochemical Conversion

This process is designed to deposit a coating on the metal surface that assists in a corrosion protection, improves electrical conductivity, or prepares a surface for painting. The process includes, (1) phosphating, (2) chromating, (3) anodizing, (4) passivation, and (5) metal coloring of lettering. Phosphate coatings provide a base for the adhesion of paints and lacquers, and also provide protection against corrosion. Chromate baths often contain hexavalent chromium, sulphuric and/or nitric acid and other organic and inorganic activating compounds. These are usually used to minimize rust formation and to increase paint adhesion. Anodizing enhances corrosion resistance through electrochemical means. Passivation forms a protective film through immersion in an acid solution (nitric acid).

Case Hardening

Case hardening produces a hard surface that remains relatively soft, making the core soft and ductile and the covering hard and durable. Case hardening procedures include, (1) carburizing, (2) carbonitriding, (3) nitriding, (4) microcasing, and (5) hardening using localized heating and quenching operations. Carburizing is the most widely used case hardening operation and involves the diffusion of carbon into steel surfaces at temperatures ranging from 845 to 955 degrees centigrade, resulting in a hard case in the high carbon area. Carbonitriding and cyaniding involve the diffusion of both carbon and nitrogen simultaneously into the steel surface. Nitriding involves the diffusion of nascent nitrogen into a steel surface producing case hardening. Additional description of case hardening methods can be found elsewhere^{2,4}. Nitriding is accomplished using either in nitrogenous gas such as ammonia or a liquid salt bath.

Chemical Coating

This can be achieved through vapor deposition and vacuum coating. Chemical vapor deposition (CVD) is the gas phase coating method analogous to electroless plating, in that it is catalytic and involves a chemical reduction of species to a metallic material which forms the coating. These reactions require high temperatures ranging from 600 to 1500 degrees centigrade. In vacuum coating, the metal coating

is vaporized in a vacuum which is low enough to ensure that most of the evaporated atoms migrate to the work piece with a few collisions with background gas molecules. Ion vapor deposition (IVD) was developed from vacuum deposition in which aluminum is used as a substitute for cadmium plating on steel parts.

Wastes

Two important waste streams generated by surface treatment are spent alkaline cleaning solutions and spent acid cleaning solutions. These are generated by periodic replacement of contaminated solutions. Waste sludge is also generated in this process. Many wastes, some of which are toxic, are associated with waste streams emerging from electroplating operations. Major components of electroplating waste streams are the rinse water that is used to drag out the excess solution, and the spent cleaning and plating solutions. These may contain a variety of heavy metals and cyanides.

MACHINING AND METAL WORKING OPERATIONS^{2,3,4,6}

The most common types of metal cutting processes are broaching, cutting, drilling, forging, grinding, milling, planing, polishing, reaming, sawing, shaping, stamping, threading, and turning. In most cases, the cutting tool travels along the surface of the work piece and shaves off the metal in front of it. The high friction at the cutting edge of the blade creates heat. If allowed to become excessive, this heat can permanently deform the part that is being formed, or the cutting tool. To prevent this undesirable effect, some form of coolant is needed. Usually, a liquid is supplied to the leading edge of the blade to create a medium with which the heat can be moved to a coolant sump.

Wastes

Wastewater expected from these operations may be classified as the hazardous waste and includes waste cutting oils and degreasing solvents. Metal chips are separated from coolants and recycled as scrap metal.

SOLVENT CLEANING AND DEGREASING OPERATIONS^{2,4,6,7}

Shipyards use solvents in a variety of cleaning and degreasing operations including parts cleaning, process equipment cleaning, and surface preparation for coating applications. Some of the major solvents used are petroleum distillates, oxygenated solvents, and halogenated solvents. Most common cleaning and degreasing operations include cold cleaning and vapor degreasing⁴.

Cold Cleaning Operations

Cold cleaning can be divided into four methods, (1) wipe cleaning, (2) soak cleaning, (3) ultrasonic cleaning, and (4) dipphase cleaning.

Wipe Cleaning

Wipe cleaning consists of using a rag or towel that has been dipped or soaked in solvent to wipe a surface clean. Wipe cleaning is usually associated with maintenance operations or processes that fabricate parts on a single item basis, such as in the machine shop.

Soak Cleaning

Soak cleaning consists primarily of soaking parts in a tank of cold solvent or solvent solution. Heating units and agitators may be added to increase the efficiency.

Ultrasonic Cleaning

Ultrasonic cleaning relies on the use of high frequency sound waves to produce cavitation in a solvent cleaning solution. Cavitation results in the formation of small vacuum bubbles that immediately collapse after formation. The rapid implosion of these bubbles creates a cleaning and scrubbing action throughout the fluid.

Diphase Cleaning

Diphase cleaning combines a water rinse both before and after the solvent cleaning step into one operation. Halogenated solvents and water are relatively insoluble so that when placed together in a tank, they separate. The water will float to the top. This causes the parts being cleaned to pass through the water bath before reaching the solvent below. After removal, the parts are rinsed by the same water. In some systems, a small pump recirculates the solvent up into a spray unit. The excess spray and runoff from the part falls back into the tank and

sinks to the bottom. The part is then cleaned as mentioned before. These systems are usually fully enclosed to reduce waste due to air emissions.

Steam Gun Stripping

In this process, a mixture of non-halogenated solvents can be added to a storage tank and fed to the steam gun. A special valve controls the amount of solvent so that the surface can be sprayed with the steam and solvent mixture. Afterwards, it is rinsed with pure steam. This operation may require large quantities of steam, and it can also generate large amounts of contaminated rinse water.

Vapor Phase Cleaning

Vapor phase cleaning relies on 'hot solvent vapor' condensing directly on cold parts inserted into the vapor space of the degreaser. As solvent vapors condense on the dirty parts, the contaminants are dissolved. The dirty solvent falls to the bottom of the tank, is reheated and vaporized, leaving the contaminants behind. As opposed to a soak tank with used solvents, vapor phase systems maintain their cleaning efficiency because the parts are always exposed to clean solvent vapors.

Water-soluble Cutting Fluids

Water-soluble cutting fluids can often be used in place of oil-based fluids. The cutting oils usually consist of an oil-in-water emulsion used to reduce friction and dissipate heat. If these fluids need to be removed after the machining process is complete, solvents may be needed.

Aqueous Cleaners

Aqueous cleaners, such as alkali, citric, and caustic base are often useful substitutes for solvents. There are many formulations that are suited for a variety of cleaning requirements. Many aqueous cleaners have been found to be as effective as the halogenated solvents that are commonly employed. As aqueous cleaners do not emit fumes or vapors, large losses due to evaporation do not occur. Since most aqueous cleaners are biodegradable, disposal is not a problem once the organic or inorganic contaminants are removed.

Mechanical Cleaning Systems

In many cases, a high pressure steam gun or high pressure parts' washer can clean parts and surfaces quicker and to the same degree of cleanliness as that of the solvents they replace. Light detergents can be added to the water supply to improve cleaning. The waste produced by these systems is usually the oily wastewater.

Non-solvent Based Paint Stripping

Non-solvent based paint stripping methods are viable substitutes for solvent stripping. Paint stripping is normally performed by soaking, spraying, or brushing surfaces with a stripping agent such as methylene chloride, chromates, phenols, or strong acids. After the agent has remained on the part for a period of time, the surface is rinsed with water and the loosened paint is sprayed or brushed off. Aqueous stripping agents, such as caustic soda, are often employed in place of methylene chloride-based strippers. Cryogenic stripping utilizes the use of liquid nitrogen and non-abrasive plastic beads as blasting shot. Abrasive blasting is the most common form of non-solvent paint stripping in shipyards. The use of various metallic grit propelled at high pressure against the surface is very effective to remove marine coatings. Thermal stripping methods can be useful for objects that cannot be immersed. In this process, superheated air is directed against the surface of the object. The high temperatures cause some paints to flake off. The removal results from the drying effects of the air and the uneven expansion of the paint and substrate. Some paints will melt at high temperatures, allowing the paint to be scraped off.

Wastes

Major wastes and materials that become contaminated with the solvents in cleaning and degreasing are various types of solvents that are employed in the process. Liquid wastes include the aqueous cleaners used, liquids contaminated with solvents etc.

WELDING AND CUTTING OPERATIONS

The main structural frame-work of a ship is made out of various grades of mild and high strength steel. Though steel dominates in ships, aluminum and other materials are used for some

superstructures like the deck-houses of ships and other specific areas within the ship. Other materials include stainless steel, galvanized steel, and copper nickel alloy that are used for a variety of corrosion resistant reasons as well as structural integrity.

Various types of welding processes are used to join the different types of metals used in the construction of ships. Fusion welding, in particular, is performed at almost all locations in the shipyard. The choice of a particular type of welding process is made depending upon the customer specifications, production rates, and the operating constraints. For commercial shipbuilding, welding processes are subject to review and approval by the regulatory bodies of the United States Coast Guard (USCG) and/or the classification societies of the American Bureau of Shipping (ABS). An important factor in welding processes is shielding. At very high temperatures, a reaction with oxygen and nitrogen is rapid and has negative effects on the weld strength apart from rendering the weld impure. To protect against this, shielding from the atmosphere is required. In most welding processes, this shielding is accomplished by addition of a flux, a gas, or a combination of the two. Some of the welding and cutting processes are flux shielded metal arc welding (SMAW), submerged arc welding (SAW), gas metal arc welding (GMAW), gas tungsten arc welding (GTAW), flux cored arc welding (FCAW), plasma arc welding (PAW), gas welding, electroslag and electro gas welding, laser welding, electron beam welding, stud welding, thermal arc and gas cutting, and mechanical cutting.

Wastes

The waste generally depends on the methods and magnitude of welding employed. The waste generated by welding of thin metals by any method is the used diluted acids. The used acid waste is collected and managed as a hazardous waste. A considerable amount of slag and wastewater is produced by these processes except for GMAW where only wastewater is produced. The wastewater is sent for onsite/offsite treatment and other wastes such as slag are disposed as solid wastes.

VESSEL CLEANING OPERATIONS^{2,4,6}

The term 'vessel cleaning' covers many different areas during the repair and construction of a ship or vessel. This work entails tank cleaning or bilge/ballast cleaning which in many cases generates a large quantity of waste which must be disposed of in an environmentally safe manner. The holding tanks that most yards use to store wastes from vessels being serviced may also be used as the repository for all the liquid waste generated at the yard.

A major portion of work at shipyards is repair work. Nearly all repair work requires vessel cleaning. The cleaning operation may be for maintenance cleaning, tank inspection, overhaul or major repair, cleaning for a change in cargo, cleaning after a contaminated cargo, cleaning in preparation for ballasting, cleaning prior to inactivation and activation of vessel, and engine room cleaning operation such as boiler line descaling and various degreasing operations. The various operations like tank washing, pipeline cleaning, mucking, chemical cleaning and chemical spot washing become a part of vessel cleaning operations.

Wastes

Wastes associated with vessel cleaning are typically generated outside the shipyard when the vessel is in use. However, because of the nature of the wastes and the way they are handled, the repair yard is frequently the generator on record. The most common of these wastes called bilge wastes is composed of wastewater containing oil and fuel removed from vessel bilges. Larger vessels may also generate sanitary wastes which usually can be discharged into a sewer directly, and chemical wastes which cannot be discharged into a sewer.

FIBERGLASS REINFORCED CONSTRUCTION OPERATIONS^{2,4,6}

The manufacture of fiberglass ships and boats involve a number of process steps which are categorized as, (1) mold preparation, (2) resin preparation, (3) gelcoat application, and (4) fiberglass application⁴.

Molds are used to give structure and support to the shape of the structure being built such as the hull of a ship or boat. Most molds are made of wood with a plastic finish. Most resins used in the process are prepromoted resins. Gelcoat

application involves application of a pigmented polyester resin or a polyester resin-based paint with a styrene content of approximately 30 percent. The application is with either an air atomizer or airless spray gun. This application is usually conducted in a spray booth. The catalyst can be added by hand mixing or by a plural component system which is injected through a separate line into the gun where it mixes with the resin. Once reheated, the polyester resin begins to thermoset. Once cured, the resin cannot be softened or reshaped by heat. The polyester resin lay-up operation results in the use of solvents. Acetone and methylene chloride are often used in this operation. These solvents are used to prevent clogging and to clean the operator's hands during clean up. For fiberglass application, the resin is either mixed, sprayed, or brushed onto the surface of the fiberglass material. The fiberglass material comes in a woven mat which is applied with the resin during fabrication.

Wastes

Wastewater generated from these operations consist of cleaning solvents from equipment cleaning and resin leftover in containers.

The above sections enumerate the different types of pollutants in wastewater streams resulting from the processes and/or operations in various shipyards. Sometimes, the wastewater streams include heavy metals as pollutants. Some processes generate liquid wastes which require handling as hazardous wastes. Such liquid wastes include wastes from photoshop, QAQC department, and other wastes like medical water, metal photo shop sealer, glue from carpentry shop, and solvents used for cleaning purposes. Great care has to be taken when heavy metals are present owing to their toxicity. Table 2 gives results of the analysis of pipe shop effluent. Though the concentrations may vary, Table 2 includes all the pollutants/parameters that may be encountered in shipyard operations.

There are other main streams of wastewater from the shipyard. They are sanitary wastewater and stormwater. The characteristics of sanitary wastewater are well known and need not be discussed in detail here. However, the stormwater characteristics may vary depending on the shops or operations located within the area of concern. The concentrations of

pollutants from stormwater outfalls of a typical shipyard are given in Table 3.

The concentration of each of the pollutants of the wastewater stream is known by running analysis of the samples collected from the sources. In case of shipyards, regulations play an important role in managing the waste streams. Permits are required to discharge the wastewater generated in the shipyard. These permits generally specify the methods by which the pollutant concentration can be known. Irrespective of whether the state, local, or parish government is issuing the permit, the methods adopted are those approved by EPA (Environmental Protection Agency).

CONCLUSIONS

The characterization of wastewater streams generated in the shipyard is necessary owing to the significant quantities generated annually. Characterization helps in segregation of waste streams into hazardous and non-hazardous wastes and employment of pollution prevention options such as source reduction, reuse and recycling, and treatment.

Characterization of waste streams can be effected by knowledge of processes/operations in a shipyard that have the potential to generate wastewater. The wastewater generated from the surface preparation operations consist of spent abrasive, paint chips, and other surface contaminants. Wastewater from metal plating and surface finishing operations comprise of alkaline and acidic cleaning solutions. Similarly, wastewater streams generated by cleaning and degreasing operations contain aqueous cleaners and spent organic solvents. Other processes/operations in shipyards generate wastewater constituents of which are known by the method(s) employed in various operations.

It is advantageous to know the strength of the pollutants in the wastewater streams for better management of the same. This can be accomplished by analysis of the wastewater preferably by EPA approved methods. The pollutants present may be biochemical oxygen demand (BOD), chemical oxygen demand (COD), total suspended solids (TSS), phenol, oil & grease, and heavy metals. The type and strength of pollutants present in the wastewater

streams determines the type of treatment that can be efficiently applied to bring the wastewater below the discharge standards.

REFERENCES

- (1) U.S. EPA, *Alternative Control Techniques Document: Surface Coating Operations at Shipbuilding and Ship Repair Facilities*, EPA 453/R-94-032, U.S. Environmental Protection Agency, April 1994.
- (2) U.S.EPA, *Guides to Pollution Prevention - The Marine Maintenance and Repair Industry*, EPA/625/7-91/015, U.S. Environmental Protection Agency, October 1991.
- (3) U.S. EPA, *Profile of the Fabricated Metal Products Industry: EPA Office of Compliance Sector Notebook Project*, EPA/310-R-95-007, U.S. Environmental Protection Agency, September 1995.
- (4) National Shipbuilding and Steel Company, *Hazardous Waste Minimization Guide for Shipyards*.
- (5) NSRP 0418, National Shipbuilding Research Program, January 1994.
- (6) U.S. EPA, *Shipbuilding and Ship Repair Industry: Background Information for Control Techniques Guidelines (CTG)*, 1993.
- (7) Avondale Environmental Department, *Avondale Waste Minimization Survey Report*, Avondale Shipyards Division, Avondale, 1995.
- (8) Draft Final Report, *Integrated Environmental Management Plan for Shipbuilding Facilities*, GCRMTC Project, June 1998.
- (9) Kura, B., and Lacoste, S., *Typical Waste Streams in A Shipbuilding Industry*, A&WMA Annual Conference, June, 1996.

Table 1. Selective shipyard processes, input materials and wastewater emissions

Process	Material Input	Wastewater Emissions
Metal cutting	Cutting oils, degreasing and cleaning solvents, acids, alkalis	waste oils (e.g., ethylene glycol) and acid (e.g., hydrochloric, sulfuric, nitric), alkaline, and solvent wastes
Solvent Degreasing and emulsion, alkaline, and acid cleaning	Solvents, emulsifying agents, alkalis, and acids	Solvent, alkaline, and acid wastes
Anodizing	Acids	Acid wastes
Chemical conversion coating	Metals and acids	Metal salts, acid, and alkaline wastes
Electroplating	Acid/alkaline solutions, heavy metal bearing solutions, and cyanide bearing solutions	Acid/alkaline, cyanide, and metal wastes
Plating	Metals (e.g., salts), complexing agents, and alkalis	Cyanide and metal wastes
Welding	Welding rods, flux coated wire, and other organic and inert gases	Diluted acids and wastewater
Painting	Solvents and paints	Solvent wastes
Other Metal Finishing Techniques (including Polishing, Hot Dip Coating, and Etching)	Metals and acids	Metal and acid wastes

Table 2. Wastewater characteristics of a typical pipe shop

Parameter	Concentration, mg/L
Biochemical oxygen demand	1358
Total suspended solids	660
Chemical oxygen demand	3720
Total organic carbon	1240
Cadmium	0.004
Chromium	0.015
Copper	6.3
Lead	0.187
Mercury	<0.002
Nickel	0.44
Silver	0.004
Tin	BQL; MQL = 0.020
Zinc	2.44
Oil and grease	133
Phenol	0.100

MQL = Minimum Quantification Level - USEPA Region VI NPDES; BQL = Below MQL

Table 3. Stormwater characteristics of a typical shipyard

PARAMETER	CONCENTRATION, mg/L			
	Outfall 1	Outfall 2	Outfall 3	Outfall 4
Oil & Grease (O&G)	3.0	7.0	2	1
Chemical Oxygen Demand (COD)	31.0	74.0	30	19
Total Organic Carbon (TOC)	8.4	14.3	7.7	7.3
Cadmium	0.02	0.04	0.06	0.09
Chromium (MQL= 0.10)	7.0	0.0	1	7
Copper (MQL= 0.10)	BQL	BQL	BQL	BQL
Lead (MQL= 0.005)	0.05	0.16	0.06	BQL
Tin (MQL= 0.02)	0.0	1.0	0	BQL
Zinc	0.02	0.04	0.02	BQL

MQL = Minimum Quantification Level - USEPA Region VI NPDES; BQL = Below MQL

Regulation of Shipyard Discharges in Australia and the Potential of UV Oxidation for TBT Degradation in Washdown Waste Water

Lyn E. Fletcher¹ and John A. Lewis²
E-Mail: john.lewis@dsto.defence.gov.au

ABSTRACT

The Royal Australian Navy uses tributyltin (TBT) antifouling paints on the major ships in its fleet. Tributyltin compounds are very effective antifoulants but have proven to be harmful to many marine organisms, and effects to non-target species have been observed in Australian inshore waters. Consequently, the use of these paints and release of tributyltin compounds into the environment have been regulated in many countries, including Australia. In Australia the regulation of TBT has been the responsibility of the individual states but it is now government policy to implement a total ban on antifouling paints containing TBT. The release of TBT contaminated wastes from shipyards and other vessel repair facilities is also coming under increasing regulatory control.

One major source of contamination is the water used to wash down ship hulls when vessels dock for repainting or refit. DSTO in collaboration with other commercial partners has been developing technologies to treat this TBT contaminated water. Contaminated wash down water has been demonstrated to be treatable using enhanced oxidation techniques. These processes produce hydroxyl radicals, which destroys tributyltin compounds by progressively converting them to much less toxic di-butyl tin, mono-butyl tin and eventually to inorganic tin compounds. Turbidity has been shown to significantly interfere with the process and trials are continuing to assess the level and type of pretreatment required.

Keywords: Tributyltin, TBT, antifouling paints, photodegradation, photocatalysts, enhanced oxidation

INTRODUCTION

Tributyltin (TBT) compounds are broad spectrum biocides used in many antifouling paints to prevent the growth of marine fouling on ship hulls. These antifouling paint systems work by slowly and continually releasing a controlled amount of TBT which is toxic to most common fouling organisms. Once released into the environment, TBT readily partitions into sediments and the surface microlayer or is degraded in the water column with a half life of around 6 days. The half life of TBT in sediments is estimated to be 3.5 years (Batley, 1995). Consequently, TBT can be quite persistent in the marine environment.

TBT readily bioaccumulates and is extremely toxic to many non-target marine organisms. Important commercial species such as oysters and other bivalves have been adversely affected by TBT pollution. The NOEL (no observable effect level) of TBT for oyster larvae has been found to be as low as 20 ng/l, with considerable mortality occurring at 50 ng/l (Alzieu, 1991). In addition, the development of male characteristics on females, termed imposex, is thought to be induced in European mud whelks (marine snails) by TBT concentrations as low as 1 ng/l (Lewis, 1998). In Australia, shell abnormalities attributable to TBT have been observed in Pacific oysters in Tasmania and Sydney rock oysters in New South Wales (Batley & Scammell, 1991). Imposex has been detected in various

¹ Aeronautical and Maritime Research Laboratory, Defence Science and Technology Organisation, GPO Box 4331, Melbourne 3001, Australia, Tel: (+61) (3) 9626-8422, Fax: (+61) (3) 9626-8999, E-Mail: lyn.fletcher@dsto.defence.gov.au

² Aeronautical and Maritime Research Laboratory, Defence Science and Technology Organisation, GPO Box 4331, Melbourne 3001, Australia, Tel: (+61) (3) 96-26-8418, Fax: (+61) (3) 9626-8999, E-Mail: john.lewis@dsto.defence.gov.au

gastropod species in Western Australia (Kohn & Almasi, 1993), South Australia (Nias *et al.*, 1993), Victoria (Foale, 1993) and New South Wales (Wilson *et al.*, 1993). In coastal waters near Perth, Western Australia, widespread contamination of TBT in the waters and sediments of the study area and the widespread occurrence of imposex in the gastropod mollusc *Thais orbita* were considered to indicate that TBT contamination of the coastal waters was an issue of extreme concern (DEP, 1996).

What exacerbates the problem, is that oyster beds and harvesting areas for many commercial species are often situated in bays, estuaries, and lagoons near harbours and marinas with high densities of pleasure craft and ships (Alzieu, 1991). High concentrations of TBT also occur near ship repair and drydock facilities (Lewis, 1993). Consequently, stringent limits for the use of TBT antifouling paints have been established which, in many Western countries, effectively prohibits the use of TBT antifouling paints on vessels less than 25 m in length (Batley, 1995). Regulations have also been imposed on land based operations to minimise TBT discharges into the marine environment. Further to this, at its meeting in November 1998, the Marine Environment Protection Committee (MEPC) of the International Maritime Organisation (IMO) resolved to implement a global ban on the application of paint containing TBT by 1 January 2003 and to a complete ban on the presence of TBT on ship hulls by 1 January 2008.

AUSTRALIAN POLICIES ON TBT

In Australia, regulation of the use of TBT antifouling paints has been the responsibility of the individual Australian States. The issues associated with the use of TBT in the Australian and New Zealand environment achieved prominence in early 1988 when detailed assessments of the use of antifoulants containing organotins were undertaken in New South Wales (Maltz, 1998) and New Zealand (Ministry for the Environment, 1988), and a conference was held to consider the Australian situation (Holmes, 1988). The issues were also addressed in New Zealand at around the same time. It was soon after this that Tasmania became the first Australian State to restrict the use of TBT, requiring all antifouling paints to be registered and imposing a ban on the use of antifouling paints

with a TBT release rate greater than 4 $\mu\text{g}/\text{cm}^2/\text{day}$. In early 1989, New South Wales introduced more stringent controls which banned the application of TBT antifouling paints to vessels less than 25 m in length. Other States followed suit using various statutory mechanisms.

As an example, in Victoria, the *Environment Protection (Organotin Antifouling Paint) Regulations 1989* were introduced under the *Environment Protection Act 1970*. These regulations stipulated that “a person must not use organotin antifouling paint on or apply it to or cause or permit it to be used on or applied to- (i) a ship which is 25 metres or less in length; or (ii) a pier, buoy, mooring or any other structure in marine or estuarine waters”. Further, it stipulated that “a person must not use organotin antifouling paint or apply it to or cause or permit it be used on or applied to a ship that is more than 25 metres in length except with the prior written consent of the Authority.” At the same time, proclamations were made under the *Agricultural Chemicals Act 1958* to prescribe tributyl tin to be prohibited for use as an agricultural chemical except where written consent was given by the Environment Protection Authority and to “declare the standard for tributyltin to be a maximum leaching rate into water of 5 micrograms per square centimetre per day of tributyltin from painted surfaces”. These regulations sunsetted on 1 June 1999 and are proposed to be replaced by a *Notifiable Chemical Order for Organotin Antifouling Paint* (Bezzobs, 1999).

New South Wales, Victoria, Queensland, Western Australia and the Northern Territory all enacted controls limiting the use of TBT paints to vessels greater than 25 m in length and with release rates greater than 5 $\mu\text{g}/\text{cm}^2/\text{day}$. Tasmania and South Australia restricted the release rates only; no greater than 4 $\mu\text{g}/\text{cm}^2/\text{day}$ in Tasmania, and 5 $\mu\text{g}/\text{cm}^2/\text{day}$ in South Australia. The US EPA Method was accepted in all states as the method for determining TBT release rates (US EPA, 1996). The Royal Australian Navy (RAN) policy is generally to use TBT antifouling paints only on HMA Ships over 40 m in length (RAN, 1994).

Moves to achieve national consistency in the management of TBT were initiated in 1989 when the Environment Council, a forerunner of the present Australian and New Zealand Environment and

Conservation Council (ANZECC), set up an *ad hoc* working group to investigate the issues. Members of the Council include State and Federal Government Environment Ministers from both Australia and New Zealand. In 1992, as part of a broader examination of the environmental aspects of shipping, the Council established a Maritime Accidents and Pollution from Shipping Task Force. This prepared a strategy, after extensive consultation, that sought to coordinate actions on all possible impacts from shipping (ANZECC, 1996a, b, c). In regard to antifouling practices, the strategy included the following objective:

“Recognising that antifouling practices have improved in recent years, promote improved standards and best practice, and development and use of more environmentally benign antifouling practices by:

- (i) adopting in general the IMO resolutions as the basis for Australian and New Zealand law, pending further review, to:
 - (a) eliminate the use of antifouling paints containing organotins (normally tributyltin or TBT) compounds on non-aluminium vessels of less than 25 metres in length;
 - (b) eliminate the use of anti-fouling paints containing TBT compounds that release more than 5 micrograms of organotin per square centimetre per day;
 - (c) develop management guidelines for ship maintenance and construction facilities to prevent the release of TBT compounds into the marine environment from maintenance and construction facilities and run-off;
 - (d) encourage the development and use of alternatives to TBT formulations that have minimal non-target effects;
 - (e) conduct monitoring to evaluate effectiveness of adopted measures;
 - (f) share information with interested parties;
- (ii) supporting, as required, the review of the ambient standards for TBT in ANZECC’s Australian Water Quality Guidelines (ANZECC, 1992);
- (iii) monitoring and reporting on progress in introducing more environmentally friendly

- antifouling practices; and
- (iv) reviewing overall progress every two years.”

An outcome of this strategy was the completion of a consultancy which developed recommendations for:

- (a) a draft code of practice for application, use removal and disposal of antifoulants and the fouling material
- (b) a draft scheme for classification of marine protective coatings including antifoulants, and
- (c) generic principles for assessing effects of antifoulants.

In late 1998 the Australian Government released the *Australia’s Oceans Policy* (Anon. 1998a, b) with the position that the Government will:

- ban the use of tributyltin (TBT) antifouling paint by 2006 on vessels being repainted in Australian docks, unless the International Maritime Organization sets an earlier date for such a ban, in which case Australia will ensure it complies with any such arrangements noting Defence’s operational requirements; and
- continue to promote the introduction of a global ban on TBT through the International Maritime Organisation.

AUSTRALIAN POLICIES ON DOCKYARD DISCHARGES

Australian States with controls over discharges have implemented these by requiring that shipyards and slipways are licensed, and imposing relevant conditions on the licence, Queensland was the first State to licence facilities to specifically address the issue of organotin wastes. The chemical control order specified that “a person could not use the chemical tributyltin other than at a place approved by the Minister”. Approval of premises for the use of TBT based antifouling paints required:

- existence of a holding facility of a capacity to contain all water from the work area, including first flush stormwater;
- provision of suitable bund walls around areas where paint removal and application are to take

- place to direct waste water to the holding facility;
- all first flush stormwater to be directed into the holding facility and to be prevented from entering the waterway
- provision of a lid over the holding facility to prevent excess rainwater from entering the pit during periods of major rainfall which may otherwise cause the pit to overflow, or alternatively an automatic facility to bypass the excess stormwater
- stormwater originating from outside the TBT work area to be diverted away from the work area
- work area to be totally above the limit of tidal influence
- techniques to be used which minimise aerial distribution of waste, ie low pressure water blasting and sponging (or wet slurry blasting) in preference to sand blasting; airless spray guns in preference to compressed air guns
- screens or enclosures to be used to minimise the aerial distribution of TBT

Other States are yet to enact similar controls, although New South Wales now requires that shipyards have a plan in place to contain, treat and/or dispose of contaminated wastes. In Victoria, the discharge of contaminated wastes is restricted under the general provisions of the Environment Protection Act which prohibits the discharge of any polluting material into waterways. In South Australia, the policy for licensing discharges specifies a maximum release rate of 5 μg tributyltin per cm^2 per day as a criteria for the protection of shellfish growing areas (EPCSA, 1992).

However, once contained, the wastes still have to be disposed of in an acceptable manner. TBT contaminated wastes are generally classified as prescribed wastes. This means that transport and disposal are subject to strict regulation. Depending on the waste, acceptable management options can include physico-chemical or biological treatment, incineration, immobilisation or, for solids and residues, landfill at approved sites. Liquid wastes can often be discharged to sewer after appropriate treatment, with the permission of the local sewerage authority.

A strong emphasis on reducing the amount of any prescribed waste at source is encouraged, and the economic expense of transport and offsite disposal of

prescribed waste is further encouragement for such an approach. There is therefore a clear need for new treatment methods and processes to remediate TBT contaminated wastes.

As previously mentioned, one outcome of the ANZECC Maritime Accidents and Pollution from Shipping Task Force was the development of a draft code of practice for the application, maintenance, removal and disposal of antifouling paints. This code proposes that the application, maintenance and removal of all antifouling coatings should only be done at facilities capable of meeting New Zealand and Australian State, Territory and Commonwealth regulatory requirements for dangerous goods, occupational health and safety and environmental protection, and appropriate standards of best practice. Further, it proposes that Australia and New Zealand should work toward uniform licensing procedures for such facilities and that the sale of antifoulants should be restricted to these facilities.

For new facilities, the code proposes that “no water should run off work areas without treatment to remove toxic substances, turbidity and discolouration. New facilities should be designed and managed so as to allow for eventual disposal to sewer of treated waste water and first-flush runoff. The acceptable standards and quality of water for disposal into sewer would come under the jurisdiction of the local sewerage authority.

For existing drydocks, slipways and hardstands, the code proposes that “measures should be adopted to minimise water runoff and certain potentially toxic, turbid or discoloured discharges. Bunds may be used on sealed concrete, sumps to contain waste water and spillages, and strawbales and woven fibre material to retain suspended solids. Existing facilities should plan for upgrading to allow for eventual disposal to sewer of waste water and first-flush runoff.

The draft code of practice is still, as designated, a draft and is yet to be discussed in detail within ANZECC. Implementation is therefore still somewhat off. In the interim, control over discharges from ship and boat yards in Australia remains the responsibility of the States and subject to their will and initiative.

ENHANCED OXIDATION OF TBT CONTAMINATED SHIPYARD WASTE WATERS

During the operational life a ship, whenever it is drydocked, and prior to repainting, the underwater hull requires washing or hydroblasting to remove the biological slime and hydrolysed surface layer of the paint. This generates significant quantities of TBT contaminated waste water. TBT concentrations in washdown waters can exceed 5 mg/l, but are usually within the $\mu\text{g/l}$ range. Where discharge has been permitted into adjacent waterways, discharge limits significantly below this have been set, for example 30 ng/l for one Australian facility. Disposal into sewer can also require a reduction in TBT concentrations and, if neither discharge is permissible, the cost for transport and disposal off-site can be high. Consequently, there is a need to find treatment methods that can reduce TBT concentrations to levels that are below the discharge limits.

Traditional biological treatment processes are not readily compatible with these wastes because of the extreme toxicity of TBT to many microorganisms. However, studies have shown that TBT compounds are susceptible to photodegradation. In a three-month study, Duhamel et al. (1987) showed that when tributyltin chloride and tributyltin oxide solutions were placed in sunlight, the TBT compounds were degraded, producing dibutyltin (DBT), monobutyltin (MBT), inorganic tin, and some polymeric organotins. Similarly, Komora and Popl (1978), using UV irradiation of tributyltin oxide found the same products after 24 hours illumination. Photodegradation, therefore, appears to be a promising technique to treat TBT contaminated wastewaters. Advanced oxidative techniques that produce hydroxyl radicals, a powerful oxidant, are methods whereby the rate of photodegradation may be enhanced.

DOCKYARD PROCESSES

In Australia there are three types of docks that are of a concern: dry docks, slipways and floating docks, and each will require different collection and holding facilities for both waste waters and abrasive blasting grits. It is anticipated that not all shipyards will be

able to meet future requirements, and these dockyards will either close or restrict their operations to non-TBT painted hulls.

Washdown wastewaters from these dockyards vary enormously. The measured TBT concentrations have been found to range from 5 $\mu\text{g/l}$ to 8 mg/l. The highest TBT concentration was recorded at a Victorian slipway, which was using a hydroblast pressure of 10,000 psi. In this case, large proportions of anti-fouling paint were being removed during hydroblasting. This is an extremely high value and includes both particulate and dissolved TBT. The washdown water from this slipway also contained dibutyltin (270 $\mu\text{g/l}$) and monobutyltin (42 $\mu\text{g/l}$). This indicates that degradation of the TBT antifoulant is already occurring on painted and fouled surface.

It was also noted that at high hydroblasting pressures (in this case 10,000 psi) aerosol formation is also a significant environmental problem. This aerosol dispersion is difficult to trap and collect at present, and improvements here will depend on the design of improved hydroblasting equipment. However, a system designed to collect first flush stormwater will help contain some of this aerosol.

Dockyard washdown wastewaters are generally collected as run-off from the dock surface. During this, the waste will have ample opportunity to collect dockyard debris and other contaminants from the dock's other activities. It has been noted that oil and grease may also be significant components of stored washdown wastewater. Therefore, the final washdown wastewater that requires treatment will be quite a non-uniform and complex waste.

PRINCIPLES OF ENHANCED OXIDATION

Due to the toxic nature of TBT, a non-biological method was sought which could destroy TBT and minimise the contaminated wastes to go to landfill. Enhanced oxidation appears to meet these objectives. Enhanced oxidation is a term given to a number of technologies that produce hydroxyl radicals. Hydroxyl radicals are very powerful oxidants that can react quickly and vigorously with a wide number of chemical substrates.

Some of the more common enhanced oxidation techniques are listed below. Those with asterisks are the techniques DSTO assessed in the laboratory for treating TBT.

- Photocatalysis* uses visible light to excite a photocatalyst, the most common being the Anatase form of titanium dioxide. It has the advantage of using a cheap source of energy source (sunlight) but the reaction is limited to the surface, and reactor design is quite complex.
- Electrolytic oxidation uses similar semiconducting materials as the photocatalysis method, but the semiconductor material is excited electrochemically.
- UV/Oxidation* is another technique gaining favour. It uses 256 nm UV light to react with either ozone or hydrogen peroxide, which through various chain reactions produces the hydroxyl radical. The disadvantages are the higher cost of energy, but scaling up to a commercial unit is simpler.
- Fentons reagent uses a mixture of iron salts and oxidants.

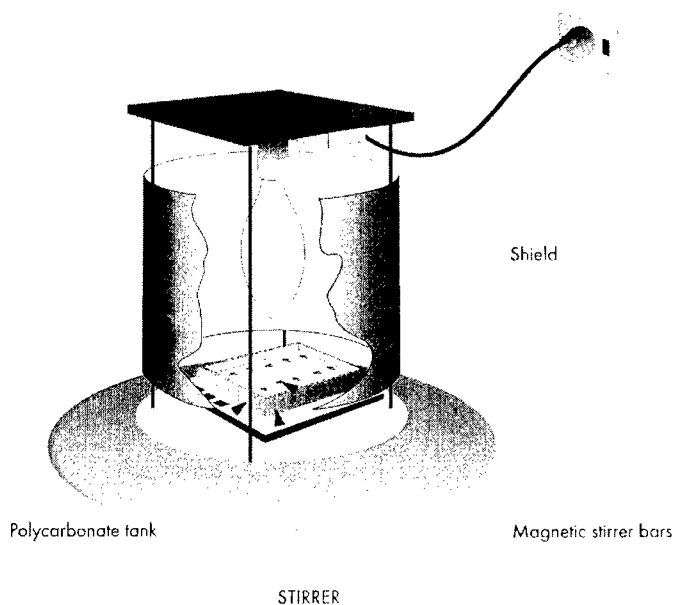

Figure 1. Schematic Diagram of the photochemical Test rig.

PHOTOCATALYTIC OXIDATION: METHOD

The photoreactor used for the experiments consisted of a 500 Watt mercury arc lamp which was suspended over a shallow polycarbonate tank measuring 300 x 150 x 70 mm (Figure 1). The tank and light were shielded with polished metal to reflect light into the centre of the photoreactor. The visible light intensity within the tank ranged from 340-720 $\mu\text{Es}^{-1}\text{m}^{-2}$, which is approximately a quarter of the intensity of sunlight. The contents of the tank were stirred with a multi-position magnetic stirrer. Sampling was done at various time intervals with the lights off. The samples were promptly wrapped in foil and frozen until analysis.

Titanium dioxide in Anatase form was obtained from Kodak. Prior to use, the titanium dioxide was heated to 550 °C for 30 minutes following the method of Matthews (1983). Polycarbonate and teflon were the only materials in contact with the test solutions.

Organotins were analysed with a Varian Star 3400 gas chromatograph with flame photometric detector. TBT acetate was converted to TBT hydride by extracting 50 ml of sample with 5 ml of analytical grade hexane, 2 ml of a 4 % w/v sodium borohydride solution and spiked with a tripropyltin chloride internal standard (Tsuda *et al.*, 1986). The solution was shaken for 30 minutes. The separated hexane fraction was then concentrated by gently blowing nitrogen gas over the solution. During the extraction procedure the suspended titanium dioxide remained in the water phase and did not interfere with the separation. The detection limit was found to be 10 $\mu\text{g/l}$. Standard curves were obtained by adding varying amounts of a stock solution of tributyltin acetate, dibutyltin dichloride and monobutyltin trichloride in methanol, to 50 ml of deionised water and extracting using the same method as the samples.

PHOTOCATALYTIC OXIDATION: RESULTS

The result shown in Figure 2 is a typical example of the change in organotin concentrations with time, and the results obtained are consistent with a sequential dealkylation degradation pathway, where tributyl tin

is converted to dibutyl tin, then monobutyl tin, and eventually inorganic tin. Consequently, the hydroxyl radical is reacting at the tin-carbon bond and removing one butyl group each time. Importantly, the toxicity of the resultant product is reduced during each dealkylation stage. Therefore, complete mineralisation to inorganic tin will not be necessary to significantly reduce the toxicity of the effluents.

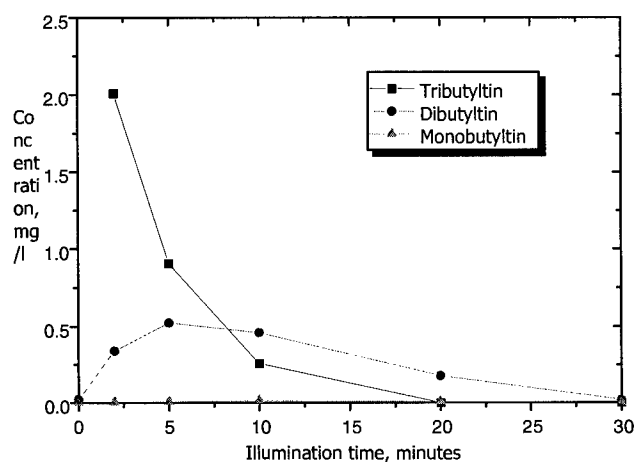

Figure 2 Typical Reaction Pathway

Another element of the observed reaction is that it is pseudo first order in character (Figure 3). Therefore, it is possible to calculate a reaction half-life for each experiment based on the slope of the line. This holds for all of the enhanced oxidation techniques so far tested with TBT. It also allows for easy comparisons, and for individual process optimisation.

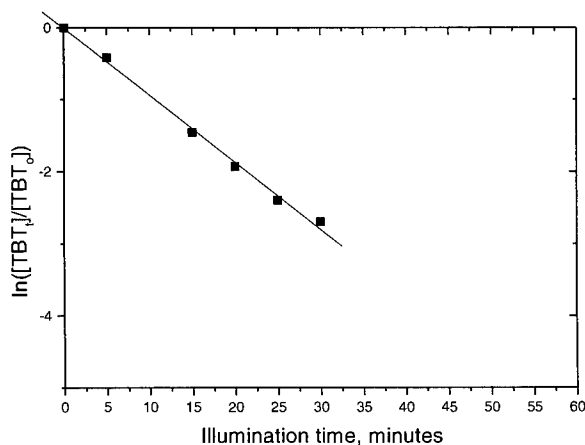

Figure 3 Pseudo first order reaction rate measured at pH = 9.3, titanium dioxide concentration of 1.0 g/l. The measured half-life in this instance is 7.4 minutes.

The photocatalytic oxidation experiments produced results that were pH dependent. This is not surprising given that hydroxide can readily be converted to the hydroxyl radical by the photocatalyst. Table 1 summarises the results obtained using a model TBT waste water in the photocatalyst test rig.

These results demonstrate that the process does not provide a useful rate of reaction until the pH is around 12.6. This is going to be a major disadvantage for any meaningful process scale-up. Consequently, the decision was made to assess another enhanced oxidation technique.

Table 1. Photocatalysis of 2.5 mg/l tributyltin acetate in deionised water, using 2.0 g/l TiO_2 , 380 nm UV light and pH adjusted using NaOH and HCl.

pH	Half life (minutes)
5.5	24.8
7.5	19.6
9.3	7.4
10.7	5.0
12.6	2.7

UV/OXIDATION: METHOD

UV/oxidation was assessed as having a number of advantages that made its investigation worthwhile. Firstly, unlike photocatalysis, the reaction is not confined to a surface and hence there is greater potential to maximise the amount of hydroxyl radical available to the process. In addition, because the reaction is not restricted to a surface, scale up to a commercial scale continuous process would be less technically challenging.

The UV/oxidation test-rig used in the following experiments was similar to the one for photocatalysis (Figure 1), but a 256 nm UV light was used to illuminate the test mixture and the shape of the rig was altered to maximise light penetration. The test mixtures included pure TBT in deionised water, used for optimisation trials, and samples of collected dockyards washdown wastewaters. Hydrogen peroxide was added prior to illumination and again samples were taken at regular intervals and stored for later analysis. Initial blank experiments were performed using only UV light and only hydrogen peroxide. Neither of these experiments

produced a significant reaction rate with TBT. This confirms that the active process observed in subsequent experiments was hydroxyl radical formation and reaction with TBT.

Organotin concentrations in the test mixtures were determined using the same method as in the photocatalytic oxidation experiments.

UV/OXIDATION: RESULTS

Initial results showed that UV/Oxidation has the same reaction pathway as the one observed for photocatalytic oxidation (Figure 1). This was expected, as the underlying reaction is the same, hydroxyl radical oxidation of the tin-carbon bond. In addition the pseudo first order reaction kinetics were again observed.

To optimise the process, the effect of hydrogen peroxide concentration was assessed. Table 2 summarises the initial investigation of the UV/oxidation process using TBT acetate dissolved in deionised water with varying amounts of 42% hydrogen peroxide. The reaction half-lives observed for UV/oxidation are at least one order of magnitude faster than the results obtained using photocatalysis (Table 1).

The optimum rate of hydrogen peroxide dosing is around 0.3 ml/litre of standard 42% hydrogen peroxide. This would mean that 1 litre of hydrogen peroxide would be needed to treat each 3,000 litres of waste. The volume of waste washdown water produced varies with size of the ship and other factors but is often around 50,000 litres for a medium-sized ship and up to 2,000,000 litres for a large ship.

Table 2. UV/oxidation of 1.0 mg/l tributyltin acetate in deionised water and pH neutral.

H_2O_2 42% _{v/v} (ml/l)	Half life (minutes)
0.05	0.68
0.1	0.63
0.3	0.37
0.5	0.43
1.0	0.49
5.0	0.97

Therefore, about 40 litre of hydrogen peroxide would be needed for a medium ship, but up to 666 litres may be needed to treat the waste produced from a large ship. Therefore, for scale-up purposes an ozone generator may be more practical.

One of the common limiting factors with reactions involving light is the effect turbidity may have on the process, by shadowing the reaction. A series of experiments were performed with waste water collected from dockyards and slipways around Australia where ships hulls painted with TBT anti-fouling paints were being hydroblasted. Selections of these experiments are presented in Table 3. Some of these were given different pretreatments to remove solids.

Table 3. Half lives of various waste-water samples

Sample Number	Turbidity (NTU)	Calculated Reaction Half life (minutes)
1	53.1	10.5
2	1.7	7.3
3	2	4.1
4	2.2	2.5
5	NA	2.1

Results show that high turbidity does affect the degradation half-life substantially, but that reasonable reaction rates can be obtained for real dockyard washdown wastewaters, provided some pretreatment to remove suspended solids is performed.

Further work using collected dockyard waste waters showed that a few major variables can have a large impact on the composition of the waste water and subsequently can effect the efficiency of the process. A summary of the major variables are discussed below.

- Paint composition was found to have a large impact, and numerous TBT antifouling paints are on the market. However, one particular observation was the affect paint pigment was found to have. In particular, the black TBT anti-fouling paints used on submarines produced the slowest reaction rates. It is suspected that the lack of the titanium dioxide white pigment in the black paint may explain this.
- The extent of the fouling increases the level of soluble organic compounds in the waste, which may also be degraded by hydroxyl radical, and compete with the TBT.

- As the pressure of the hydroblasting increases, more paint is removed, which results in higher strength wastes, putting more demands on the UV/oxidation process.
- How the waste is collected can also have a large impact, ie is it diluted with other wastes, is it allowed any settling, and does it pick up much additional debris.

FUTURE DIRECTIONS

DSTO is continuing to assess pretreatment options to develop a complete treatment option for dockyard wastes, and has established a partnership with Australian Water Technologies to develop and test a pilot plant based on the above scheme.

The cyclonic DAF is a new Australian invention for solids removal, which produces small air bubbles by cyclonic vortex. This reduces the need for high-pressure pumps that are required for more traditional dissolved air flotation devices. This unit will improve the economics of the process considerably, and is currently being assessed by Australian Water Technologies for the pretreatment process to remove suspended solids and turbidity.

A trial is being negotiated currently at a large Australian Dockyard.

REFERENCES

- Alzieu, C. (1991) Environmental problems caused by TBT in France: Assessment, regulations, prospects? *Mar. Environ. Res.* **32**, 7-17.
- Anon. (1998a) *Australia's Oceans Policy. 1. Commonwealth of Australia.*
- Anon. (1998a) *Australia's Oceans Policy. 2. Specific Sectoral Measures.* Commonwealth of Australia.
- ANZECC (1992) *The ANZECC Australian Water Quality Guidelines for Fresh and Marine Waters.* National Water Quality Management Strategy.
- ANZECC (1996a) *Working together to reduce impacts from shipping operations. ANZECC strategy to protect the marine environment. Volume 1 – Strategy and action plan.* Australian and New Zealand Environment and Conservation Council.
- ANZECC (1996b) *Working together to reduce impacts from shipping operations. ANZECC strategy to protect the marine environment. Volume 2 – Technical annex.* Australian and New Zealand Environment and Conservation Council.
- ANZECC (1996c) *Working together to reduce impacts from shipping operations. ANZECC strategy to protect the marine environment. Volume 3 – Analysis and evaluation of industry and community comments.* Australian and New Zealand Environment and Conservation Council.
- Batley, G E (1995) Heavy metals and tributyltin in Australian coastal and estuarine waters. In, Zann L P and Sutton, D (Eds), *State of the Marine Environment Report for Australia, Technical Annex: 2 Pollution*, pp. 63-72. Department of the Environment, Sport and Territories, Canberra.
- Batley, G.E. & Scammell, M.S. (1991) Research on tributyltin in Australian estuaries. *Appl. Organometal. Chem.* **5**, 99-105.
- Bezzobs, T. (1999) Review of the *Environment Protection (Organotin Antifouling Paint) Regulations 1989* and draft Notifiable Chemical Order impact assessment. *Publication 656.* Environment Protection Authority, State Government of Victoria.
- DEP (1996) Southern Metropolitan Coastal Waters Study (1991-1994): Final report. *Report 17.* Department of Environmental Protection, Perth, W.A.
- Duhamel, K., Blanchard, G., Dorange, G. and Martin, G. (1987) Recovery of all species from photolytic degradation of tributyltin compounds TBTX (X=Cl, OSnOBU₃). *Appl. Organometal. Chem.* **1**, 133-142.
- EPCSA (1992) *Marine Environment Protection Act: Guidelines for Licensing.* Environmental Protection Council of South Australia. Department of Environment and Planning, South Australia.

- Foale, S. (1993) An evaluation of the potential of gastropod imposex as a bioindicator of tributyltin in Port Phillip Bay. *Mar. Pollut. Bull.*, **26** (19), 546-552.
- Holmes, N. (Ed.) (1988) *Proceedings of the Conference on Organotin Materials in the Marine Environment*. Centre for Coastal Management, Northern Rivers College of Advanced Education, Lismore, NSW.
- Kohn, A.J. & Almasi, K.N. (1993) Imposex in Australian *Conus*. *J. Mar. Biol. Ass. U.K.* **73**, 241-244.
- Komora, F. and Popl, M. (1978) The resistance of bis-tributyltin oxide to oxidation and elevated temperatures. Multilingual Services Division, Canada. Unedited translation from: *Holztechnologie* **19** (3), 145-147.
- Lewis, J.A. (1988) Organotin antifouling paints and the environment. *Surface Coatings Aust.* **25** (11), 18-25.
- Lewis, J.A. (1993) Antifouling technology and the environment. *Proceedings, Maritime Technology, 21st Century Conference, Melbourne*, 1, Section 2.1x.
- Lewis, J.A. (1998) Marine biofouling and its prevention on underwater surfaces. *Materials Forum*, **22**, 41-61.
- Maltz, A. (1988) Assessment of organotin compounds, especially tributyltin compounds used as antifoulants. *Environmentally Hazardous Chemicals Act, 1985: Assessment Report*. State Pollution Control Commission, New South Wales.
- Matthews, R.W. (1983) Hydroxylation reactions induced by near-ultraviolet photolysis of aqueous titanium dioxide suspensions. *J. Chem. Soc. Faraday Trans. 1* **80**, 457-471.
- Ministry for the Environment (1988) Report of the working party reviewing the use of antifoulants containing organotins in New Zealand. Ministry for the Environment, Wellington, New Zealand.
- Nias, D.J., McKillup, S.C. & Edyvane, K.S. (1993) Imposex in *Lepsiella vinosa* from southern Australia. *Mar. Pollut. Bull.* **26** (7), 380-384.
- RAN (1994) *ABR 19 - RAN Painting Manual, Volume 2*. Department of Defence (Navy Office), Canberra, ACT
- Tsuda, T., Nakanishi, H., Morita, T. & Takebayashi, J. (1986) Simultaneous gas chromatographic determination of dibutyltin and tributyltin compounds in biological and sediment samples' *J. Assoc. Off. Anal. Chem.* **69** (6), 981-984.
- US EPA (1996) *Tributyltin Data Call In Notice*, July 29, 1986. (U.S.) Environmental Protection Agency, Washington, D.C.
- Wilson, S.P., Ahsanullah, M. & Thompson, G.B. (1993) Imposex in neogastropods: an indicator of tributyltin contamination in eastern Australia. *Mar. Pollut. Bull.* **26** (1), 44-48.

Real Time Copper Measurement (Of US Navy Dry Dock Effluent)

Mike Putnam

Space and Naval Warfare Systems Center, San Diego, CA

ABSTRACT

Due to its toxicity, copper is a high profile pollutant with many diverse sources such as ship hulls, process water and cooling water effluent. All fixed US Naval dry docks utilize a water collection system that allows process water (stormwater runoff, seawater leakage, freeze protection water, and ship discharges) to be discharged to the surrounding marine waters or to be diverted to a treatment system depending on the contaminant load. Current control systems typically monitor water flow into the system, and divert water for treatment under initial high flow conditions based on a premise that contaminant loads, particularly copper, increase when inputs, such as first-flush stormwater, are highest. A preferable method to monitor this process water would utilize a more relevant measure of contaminant load. While copper concentration would be one obvious parameter to measure, the ability to do so in a continuous, real-time manner, in an industrial setting, and at a reasonable cost has been problematic.

Key Words: Copper, Dry Dock, Effluents, measurement

INTRODUCTION

Currently, US Navy ships use copper-based paints for antifouling. Aircraft carriers, the largest of these ships, contain over 1.3×10^5 m² of antifouling paint area. When ships are undergoing repair and maintenance in dry docks elevated copper levels in dry dock effluent is a constant concern.

In marine waters, copper can exist in various physico-chemical forms¹ i.e., dissolved, particulate, as a colloid, inorganically and/or organically complexed, or as a hydrated divalent ion. In the US, water quality criteria are set by regulators using dissolved copper concentrations. However, in National Pollution Discharge Elimination System (NPDES) permits copper discharges into marine waters are regulated using total copper concentrations. To further complicate matters, many researchers believe that the response of marine organisms exposed to copper toxicant

correlates poorly with copper's dissolved concentration and is largely dependent on the hydrated divalent ion concentration ($\text{Cu}^{2+}_{(\text{aq})}$). Until consensus is reached on what species of copper to measure, any real time automated copper instrumentation must have a tight correlation with total copper concentrations measured using standard laboratory techniques.

NEED FOR MONITORING

All fixed dry docks such as those found at US Naval Shipyards are required to collect and treat effluents exceeding permit levels. Flow rates at large dry docks may reach 4×10^8 L/day making treatment of all process water impractical and exceedingly expensive, with treatment cost typically around \$(US)0.04/L. Fortunately, through best management practices the majority of water collected contains less than 10 µg/l Cu and does not require treatment.

The current flow rate diversion control systems are set to minimize discharge mistakes, which probably results in over treatment and unnecessarily high treatment costs. Based on once a week outfall monitoring, over a 4 year period at Puget Sound Naval Shipyard, a flow based treat or discharge system resulted in incorrectly discharging, rather than treating, approximately 4% of the time. This data does not indicate is how much process water is needlessly treated by this type of diversion control.

COPPER BASED CONTROL

To be a viable alternative to flow rate diversion control a copper based control system must be reasonably priced, able to operate in a continuous unattended mode, require minimal maintenance, be rugged enough to operate in an industrial environment, and the measurement must exhibit a tight correlation to total copper concentrations. This last criteria is the most difficult to meet for an online system. The major source of copper in dry dock effluent varies depending on the operations being conducted inside the dry dock. During docking evolutions, with a freshly painted hull the majority of copper is in the dissolved phase. While, during some ship maintenance tasks most of the copper will be found in metal alloy particulates.

INSTRUMENTATION

Recently two promising technologies have emerged that allow real time copper measurement. The first technology, the Trace Metals Analyzer (TMA), utilizes potentiometric stripping analysis (PSA), and is currently undergoing demonstration and validation under the Zero Discharge Industrial Waste Water Treatment Plant Project at the Puget Sound Naval Shipyard. The second technology utilizes a copper ion selective electrode (Cu-ISE) for measurement of copper activity in seawater. A system utilizing this sensor is currently being used to meet a NPDES permit requirement to monitor the copper levels of a power plant discharging 2.3G liters per day of cooling water effluent into the marine environment.

PSA

Potentiometric stripping analysis for metals was pioneered by D. Jagner². This method monitors the voltage changes, at an electrode, during metal plating and stripping at the electrode. Through the use of standard additions the precise initial concentration of metals can be determined. An excellent summary of the technology can be found in the introductory text by J. Wang³.

The TMA, utilizing PSA, preacidifies the effluent sample to below pH 2 before conducting an analysis. As can be seen from Figure 1 this enables the instrument to achieve, in marine waters, a close correlation with total copper laboratory measurements utilizing acid digestion and measurement with a graphite furnace atomic adsorption instrument.

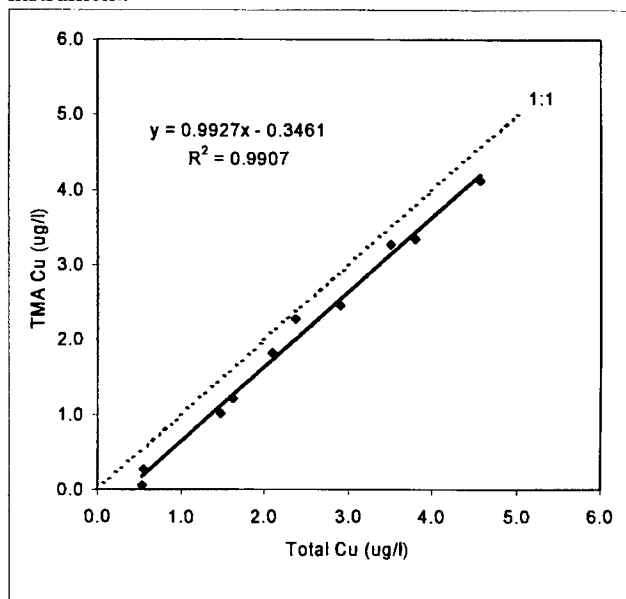

Figure 1. Copper levels from seawater samples collected from San Diego Bay. The copper concentration were determined using the Trace Metals Analyzer and graphite furnace atomic adsorption utilizing pre-acid digestion.

Although, the TMA is in excellent agreement with standard methods several factors make it less than ideal for dry dock monitoring. First, the TMA was developed as a laboratory/field instrument capable of generating data comparable to the best of laboratory methods. It achieves this accuracy in part by utilizing very high precision miniature pumps, which do not have the capability to survive in an industrial environment over long periods of time. Another drawback is cost. The commercialized cost will be around \$(US)40k making wide spread use at a multi-dry dock shipyard facility expensive at best. Finally, the TMA is not a continuous flow through system. The sample rate, at maximum precision, is approximately four samples per hour. Sampling rates can be increased up to eight per hour at reduced precision.

Cu-ISE

The Cu-ISE system utilizing the Orion 94-29 electrode has been demonstrated to be an accurate tool for measurement of the activity of $\text{Cu}^{2+}_{(\text{aq})}$ and in determination of marine water copper complexation capacity⁴. However, at natural marine water pH there is a poor correlation with total copper (Figure 2). DeMarco⁵ shows that measurements made with the Orion electrode on marine waters acidified to pH 2 correlate well with dissolved copper measurements.

The advantages of the Cu-ISE are simplicity, ease of use, low cost, and a wide dynamic range ($10^{-15} \text{ M} - 10^{-1} \text{ M Cu}^{2+}$). In addition, industrial prototypes are currently in use measuring copper activity during in-water hull cleaning

Towards a Total Copper Instrument

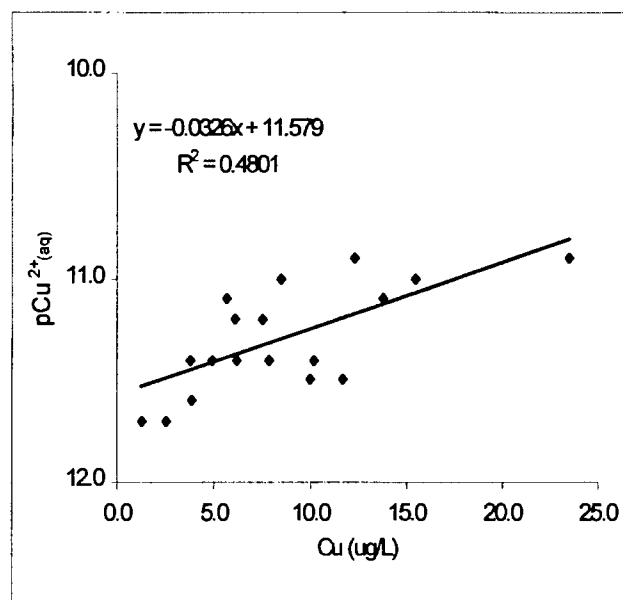

Figure 2. Correlation between total copper and copper activity, measured in pCu, at pH 8. The unit pCu is similar to pH in that it is the inverse log of the copper ion activity.

operations and monitoring the increase in copper activity of power plant cooling water discharges.

The difficulty in developing an instrument for measuring copper in dry dock effluents lies not in the sensing part of the equation, as discussed above, but in the in-line and real-time pretreatment of the effluent to release the tightly bound copper before it enters the steel alloy particles. These fine particles are particularly resistant to extraction by low pH alone. Current work in this area is examining various approaches to this challenge. Ongoing development is examining the use of ultrasonics, ultraviolet radiation, pressure and heat, in addition to a lower pH.

The ideal inline system would utilize a Cu-ISE with a variable pretreatment system. This system would allow a sequential determination of the effluents copper speciation. This more complete picture would not only allow a treat or discharge determination, but would enable the dry dock operators to isolate problem sources of copper and assist them in determining the true impact of copper discharges on the environment.

REFERENCES

1. Zirino, A., Belli, S. L., VanderWeele, D. A., *Electroanalysis*, 1998, 10, 6, 1493.
2. Jagner, D., *Analytical Chemistry*, 1978, 50, 13, 1924.
3. Wang, J., *Stripping Analysis: Principles, Instrumentation and Applications*, VCH, New York, 1985.
4. Zirino, A., VanderWeele, D. A., Belli, S. L., DeMarco, R., Mackey, D., *Marine Chemistry*, 1998, 61, 173.
5. DeMarco, R., Mackey, D., Zirino, A., *Electroanalysis*, 1997, 9, 4, 330.

Discharge of Tributyltin Into State of Virginia Waters

David Johnson
Deputy Director, DEQ
Commonwealth of Virginia

ABSTRACT

The purpose of this paper is to review the impact of the Commonwealth of Virginia regulatory strategies, policies, and economic development projects related to the use of TBT in antifouling boat bottom paints. The Commonwealth of Virginia is the only State to have a NPDES Discharge Regulation for Tributyltin (TBT) at 50 parts per trillion as a discharge standard for discharged washdown wastewaters from shipyards and drydocks as means of reducing local environmental contamination from TBT.

The Commonwealth's concern about preventing the economic loss of business by Virginia shipyards to non-regulated countries and the impact on Virginia's shipping industry from increased fuel and operating costs led the Commonwealth of Virginia to establish a R&D Project at the Center for Applied Ship Repair and Maintenance (CASRM) in Norfolk, Virginia.

The purpose of this project (which is co-funded by the U.S. Environmental Protection Agency and the Norfolk shipyards) is to develop advanced technologies to remove TBT from ship washdown wastewaters.

Keywords: Commonwealth of Virginia, Tributyltin, regulations, NPDES, regulated discharges from shipyards, TBT advanced treatment technologies, washdown wastewaters.

INTRODUCTION

The first use of organotin as a biocide (toxin) in marine coatings and paints was to reduce biofouling (growth of plants and animals) on boat bottoms in the early 1970s. In 1974, oyster growers first reported the occurrence of abnormal shell growth in *Crassostrea gigas*, the pacific oyster along the East Coast of England (Key et al., 1976).

However, it wasn't until the mid 1980s, that researchers in France and the United Kingdom began to suggest that the use of TBT in antifouling paints was adversely impacting a number of marine species other than the fouling organisms. This economically important species is *Crassostrea gigas*, the pacific oyster, which is farmed in coastal waters of England and France (Alzieu, 1991; Davis et al., 1988; Thain, 1983; Thain et al., 1987; Waldock, 1986; His and Robert, 1983-1985; His, 1996 and references therein).

Subsequently imposex (development of penis) in female dogwelks was correlated to the presence of TBT in coastal waters (Davies and Bailey, 1991; Gibbs and Bryan, 1996; Gibbs et al., 1988, 1991; and Ten Hallers-Tjabbes et al., 1994).

However it was not until the mid 1980's that the effect of the use of TBT in antifouling paints was seen in the United States. Professor Edward D. Goldberg, of the Scripps Oceanographic Institute, has stated that "TBT is perhaps the most toxic substance ever deliberately introduced to the marine environment by mankind" (Goldberg,

1986). A deformed oyster was found in Coos Bay in Oregon by Wolniakowski et al. (1987).

Since the Pacific oyster is from Japan, in the UK, France, and the U.S., it is cultivated as a commercial species. It is the only species of oyster that has been found to demonstrate abnormal growth from exposure to TBT. The difficulty in delineating cause-and-effect relationships and the effects on untargeted species attracted national and international concern, see Champ and Seligman (1996); and de Mora (1996) for an overview of organotin environmental fate and effects.

Oysters in Virginia Waters

In Chesapeake Bay, Growth Abnormalities have not been found in the Virginia native species, the Eastern Oyster (*Crassostrea Virginica*), but larval toxicity is in the parts per billion ($\mu\text{g/L}$) levels. Oyster production in Virginia waters of Chesapeake Bay is a significant marine resource and economic base for local economies. Oyster production in the Bay has declined since the early 1980's. The difficulty in delineating cause-and-effect relationships and the levels measured in Bay and tributary waters attracted the interest of Virginia marine scientists.

After the implementation of national restrictions by the United States, France, United Kingdom, and others in the mid to late 80's, there has been about a decade of assessing the effectiveness of the initial regulations without subsequent additional or more restrictive regulations. Austria and Switzerland banned the use of TBT even though they are land locked. Japan banned the use of TBT in 1990. New Zealand's restriction of the use of TBT-based antifoulant paints in 1989 increased the use and marketing of copper-based marine coatings in the South Pacific as alternatives to TBT as being "environmentally friendly" (de Mora, 1996).

U.S. Regulatory Actions

In the U.S., regulatory actions for TBT stem from the Navy's Environmental Assessment of Interim Finding of Non Significant Impact (FONSI). The U.S. Navy reviewed the British studies by Thain (1983), Waldock and Miller (1983), Waldock et al. (1983), Alzieu and Portman (1984), and the French studies by Alzieu et al. (1981-1982); His and Robert, 1983-1985); and Alzieu et al. (1986).

The Navy's decision to not use TBT was based on: (1) excessive use of free-association TBT-based paints on small recreation boats in Europe, which were primarily used in shallow coastal estuarine waters where oysters were grown; (2) Navy ships were mostly seagoing vessels and spent only minimal periods of time in harbors or shallow coastal waters; (3) the Navy was proposing to use TBT-based co-polymer paints with low release rates, so that the impact on non target organisms would be very limited; and (4) the cost benefits from the use of these coating were estimated to be from \$ 100 to \$ 130 million annually in fuel avoidance (savings) costs and millions in annual maintenance costs (NAVSEA, 1984, 1986; Bailey, 1986; Eastin, 1987; Ricketts, 1987 and Schatzberg, 1987).

Subsequently, Virginia Senator Triple was concerned that the Navy would be able to use TBT and it would impact oysters in the lower Chesapeake Bay. He inserted language in the 1986 Report of the Continuing Resolution for the FY86's Federal Budget requiring to the effect that the Navy would have to have approval from EPA to use TBT. The Navy did not fully appreciate that the sensitivity of TBT in coastal states and by members of Congress and that EPA's regulatory process could prevent them from using TBT. The Navy's position was based on advice from its legislative advisors in Congress, that EPA would be able to easily give the Navy a variance for the

use of TBT, due to the reasons listed in the above paragraph. To the Navy's surprise, it subsequently learned that once EPA initiated the Special Review process that EPA would not be able to make any decisions until the process was completed.

The U.S. Environmental Protection Agency (EPA) on January 8, 1986, announced the initiation of a Special Review of all registered pesticide products containing TBT compounds used as biocides in antifouling paints and the Navy subsequently shifted to Copper-based antifouling paints.

About the same time, U.S., academic researchers and state water quality boards or state natural resource agencies in a few key coastal states (Virginia, North Carolina, California, Oregon, and Washington) began to closely follow the organotin issues in France and the UK, and investigated their coastal waters for similar effects. The only published paper finding deformed oysters in the U.S. is by Wolniakowski et al. (1997) for a specimen found in Coos Bay, Oregon. For additional information on TBT concentrations in U.S. and Canadian waters, see papers published in the Proceedings of the International Organotin Symposia (1986, 1987, 1988, 1989 and 1990). In addition, see the following citations and references cited therein: Seligman et al. (1996a and 1996b); Grovhoug et al. (1996); Maguire and Hale (1981); Maguire et al (1982; and 1986); and Maguire (1996).

The Antifouling Paint Control Act of 1988

Organotins are the only chemical compound regulated by law in the United States in which environmental legislation has been enacted solely for the chemical by name - The Organotin Antifouling Paint Control Act of 1988 (U.S. Congress, 1988). The purpose of the Act was "to protect the aquatic environment by reducing immediately the quantities of organotin entering the waters of the United States."

The prohibitions in the Act are: "No person in any State may apply to a vessel that is less than 25 meters in length an antifouling paint containing organotin" with the following exceptions: "(1) the aluminum hull of a vessel that is less than 25 meters in length; and (2) the outboard motor or lower drive unit of a vessel that is less than 25 meters in length."

No person in any State may: (1) sell or deliver to, or purchase or receive from, another person an antifouling paint containing organotin; or (2) apply to a vessel an antifouling paint containing organotin; unless the antifouling paint is certified by the Administrator [of EPA] as being a qualified antifouling paint containing organotin, and (3) sell or deliver to, or purchase or receive from, another person at retail any substance containing organotin for the purpose of adding such substance to paint to create an antifouling paint.

A key certification was that the EPA Administrator shall certify each antifouling paint containing organotin that the Administrator has determined has a release rate of not more than 4.0 micrograms per square centimeter per day.

In addition, the Act required the Administrator of the U.S. EPA, in consultation with the Under Secretary of Commerce for Oceans and Atmosphere (NOAA), was required to monitor the concentrations of organotin in the water column, sediments, and aquatic organisms of representative estuaries and near-coastal waters in the United States.

The Secretary of the Navy was to provide for periodic (not less than quarterly) monitoring of waters serving as the home port for any Navy vessel coated with an antifouling paint containing organotin compounds to determine the concentrations of organotins in the water column, sediments, and aquatic organisms of such waters. These monitoring programs were to remain in

effect for 10 years or until the last U.S. Navy ships coated with TBT paint had been removed from service.

Although OAPCA and subsequent U.S. EPA regulations allowed use of TBT coatings by large vessels, the U.S. Navy in 1989 decided not to use organotin coatings because of environmental concerns and the uncertain regulatory future at the State and regional levels. Following enactment of OAPCA, the following monitoring programs were conducted: (1) the in-house Navy monitoring studies from 1984 to 1987 in San Diego bay, Pearl Harbor, the Norfolk region and 12 other harbors, and Navy dry dock release rates studies that were conducted between 1989 and 1995, (2) the monitoring program that was required by EPA of the paint manufactures as part of the TBT permit process, and (3) the NOAA National Status and Trends Program added the analysis of TBT to their coastal monitoring program (sediment and oyster tissue) to establish a base line for commercially representative and important populations (Seligman et al., 1990; U.S. EPA, 1991; U.S. Navy, 1997).

COMMONWEALTH OF VIRGINIA (STATE OF VIRGINIA)

By mid 1987, most coastal states were planning or had implemented restrictions on the use of organotins. Virginia was among the first to become concerned and implemented a regulatory strategy developed by the Virginia Water Control Board after which the subsequent U.S. federal law was modeled. One of the areas that States could regulate organotin usage was linked to the ambient water quality concentrations of organotins through State Environmental Quality Standards.

Studies initiated in 1984 by Robert J. Huggett and others at the Virginia Institute of Marine Science for the lower Chesapeake Bay were finding high concentrations of TBT near drydocks and

shipyards. See the following citations and references cited in Hall, 1986, 1988; and Hall et al., 1986, 1987; Huggett, 1986, 1987; Huggett et al., 1986, 1992, and 1996; Evens and Huggett 1991; and USEPA, 1987).

During 1986, a series of articles were written by Bruce Reid and published by the Daily Press/The Times-Herald, a local newspaper in Newport News, Virginia. Reid was the first in the U.S. to report on the impact of TBT on oysters in France and the U.K. and on the dangers and public health risks to shipyard workers applying TBT-based antifouling paints. He also reported on a variety of health problems that shipyard workers reported after they started welding and performing other work on the hulls of vessels painted with TBT. The workers symptoms included chronic skin inflammation, respiratory problems, headaches, stomachaches, burning eyes, dizziness, fatigues and frequent colds and flues. One article covered the lawsuit being considered by Charleston shipyard workers, due to a wide range of respiratory problems and constant headaches and coughing related to applying TBT-based paints. The possible human health risks to shipyard workers that were identified subsequently ranged from dermatitis to cancer. Shipyards in Virginia (that painted naval ships, cruise ships, and cargo vessels) supported the regulation of TBT because it would protect their workers.

Subsequently, after hearings in the U.S. Congress, key U.S. Congressmen from coastal states believing that the EPA regulatory process would be too slow, proposed the "Organotin Antifouling Paint Control Act of 1988" (OAPCA) which was signed into United States law by President Reagan on June 16, 1988. Coded in this law, P.L. 100-333, (33 USC 2401) are the United States Federal laws and regulations concerning the use (and subsequent disposal) of organotin compounds as additives or biocides in antifouling boat bottom paints. It should be noted that the concern for

TBT by leading U.S. researchers and the interest by the Commonwealth of Virginia helped Congress to quickly draft U.S. national legislation.

The predicted impacts of TBT regulations in the U.S. and the Commonwealth of Virginia by the chemical manufactures and paint companies (Gibbons, 1986) were:

- Higher fuel costs for shipping.
- Dramatic increase in operating costs for domestic vessels.
- Higher antifoulant protection costs to vessel owners.
- Deepsea vessels would go to foreign shipyards for painting.
- Severe hardship to u.s. shipyards (125,000 workers).
- TBT ban would push many shipyards over the edge, and foreign vessels, and shipyards would capture market.
- TBT painted hulls would still be in U.S. waters.

Virginia initially accepted the EPA advisory allowable level of 10 ng/L for salt water. However immediately upon passage of OAPCA, the Virginia Water Control Board indicated that it thought that the level should be reduced to 1.0 ng/L (Commonwealth of Virginia, 1988) and was subsequently followed by the State of California with a level of 6.0 ng/L. Virginia also passed a state law that set the release rate at not greater than 4 $\mu\text{g}/\text{cm}^2/\text{day}$ (U.S. Congress, 1987a; and 1987 b).

The Commonwealth of Virginia also was the only U.S. State to set National Pollution Discharge Elimination Standard (NPDES) Permit levels for TBT at 50 ng/L from shipyards and drydocks in state waters. It gave shipyards a 5-year compliance period that ended in September 1999 to meet this standard. Hull wash down is a 30 hour operation using 400,000 + Liters of wash water, resulting in TBT levels in wash down waste water ranging from 15,000 ng/L to 485,000 ng/L.

In 1998, it became apparent that shipyards were not able to comply with regulations using Best Management Practices (BMP's) and Best Available Technology (BAT). During this time period, it became apparent that Virginia shipyards could not effectively compete in the non-environmentally-regulated-global marketplace. Part of the problem was expertise to conduct R&D, and the cost of quickly developing a TBT waste treatment system that would achieve a regulated discharge (environmental water quality standard) level to protect local waters. The impact of not painting ships with TBT on the Hampton Roads economy has been estimated to be a loss of \$ 340.2 million and 2,160 jobs (Godfrey, Jr., 1999, Personal Communication).

This led Virginia legislators at State and Federal levels to develop a cooperative R&D Project, which was initiated during the summer of 1999. The project is supported by the U.S. EPA, The Chesapeake Bay Foundation, and local shipyards in the Norfolk, Virginia area through CASRM (Center for Applied Ship Repair and Maintenance) at Old Dominion University to develop TBT wastewater treatment technologies for shipyards and drydocks to meet these standards. The need for this project stemmed from two CASRM projects funded by the NSRP on stormwater collection, characterization, treatment, recycling and reuse and discharge (CASRM, 1996, 1997).

SUMMARY AND CONCLUSIONS

The long-term economic and environmental public policy and regulatory strategies goals for antifouling marine coatings should be that vessels (regardless of length) need effective antifouling coating technologies and that this effectiveness not impact non-target organisms. The regulation of antifouling coatings is a genuine public policy concern because their selection influences the public costs for vessel shipped common goods, food, energy, etc.

Most effective antifouling coatings today contain toxic additive substances known as biocides. Organotin compounds have been found to be the most effective biocides developed to date. For a regulatory strategy to be supportive of the creation of high technology chemicals and products, it must include the promotion of continued research and development to push these compounds to additional refinements that enhance environmental attributes. This R&D must also include clean up and treatment technologies and systems, to be able to improve Virginia industries competitiveness in the global market place.

It is easy for regulation to have the unintended consequence of inhibiting economic development of products and technologies. The impact of regulations in Virginia has been a continued reduction in TBT levels in the marine environment since 1987 and control of point source discharges from shipyards now at less than 100 ng/L levels.

However, the Department of Environmental Quality of Virginia is still concerned about the lack of control on the largest non-point source of TBT to Virginia's coastal waters, since TBT leaching from vessel hulls in ports is not regulated and it believes that international regulation is required to reduce these levels.

The interests of the Commonwealth of Virginia are: reducing environmental and public health risks; protecting the marine environment; promoting economic development; competitiveness of Virginia shipyards, drydocks and ports (Virginia is home to the second-largest port facility on the East Coast), and creating jobs). The Commonwealth of Virginia has in place NPDES Discharge Permit Regulations to protect the marine environment and has funded R&D to develop TBT Waste Water Treatment Technologies for Shipyards and Drydocks. These actions will protect jobs in the seafood industry, shipyards industry and the shipping industry.

REFERENCES CITED

- Alzieu, Cl., M. Héral, Y. Thibaud, M.J. Dardignac, and M. Feuillet. 1981-1982. Influence des peintures antisalissures à base d'organostanniques sur la calcification de la coquille de l'huître *Cassostrea gigas*. *Rev. Trav. Int. Pêches Marit.* **45**:101-116.
- Alzieu, Cl., and J.E. Portman. 1984. Effect of tributyltin on the culture of *Crassostrea gigas* and other species. Proceedings of the 50th Annual Shellfish Conference. pp. 87-104.
- Alzieu, Cl., J. Sanjuan, J. Deltreil, and M. Borel. 1986. Tin contamination in Arcachon bay: effects on oyster shell anomalies. *Marine Pollution Bulletin.* **17**:494-498.
- Alzieu, Cl., J. Sanjuan, P. Michell, M. Borel and J.P. Dreno. 1989. Monitoring and assessment of butyltins in Atlantic coastal waters. *Marine Pollution Bulletin.* **20**(1):22-26.
- Alzieu, Cl. 1991. Environmental problems caused by TBT in France: Assessment, regulations, prospects. *Marine Environmental Research.* **32**:7-17.
- Bailey, W.A. 1986. Assessing impacts of organotin paint use. Proceedings Oceans '86 Organotin Symposium. Marine Technology Society. Washington, D.C. Vol. 4:1101-1107.
- CASRM (Center for Applied Ship Repair and Maintenance) 1996. Stormwater collection, treatment, recycling and reuse in a shipyard. (Osman, et al.). CASRM, Old Dominion University. Final Report. NSRP Project. 6 Sections.
- CASRM (Center for Applied Ship Repair and Maintenance) 1997. Characterization of stormwater discharge from a marine drydock. (Schafran, et al.). CASRM, Old Dominion

University. Final Report. NSRP Project N1-96-07. 35p + 3 Appendices.

Champ, M.A. and D.F. Bleil. 1988. Research needs concerning organotin compounds used in antifouling paints in coastal environments. NOAA Technical Report Published by the Office of the Chief Scientist. National Ocean Pollution Office. 5 Parts Plus Appendices.

Champ, M.A. and P.F. Seligman. 1996. Organotin: Environmental Fate and Effects. (Editors) Chapman & Hall. London. 623p.

Commonwealth of Virginia. 1988. State Water Control Board Proceedings, 27-28 June. Richmond, Virginia.

Davies, I.M., J. Drinkwater and J.C. McKie. 1988. Effects of tributyltin compounds from antifoulants on pacific oysters *Crassostrea gigas* in Scottish Sea Lochs, U.K. *Aquaculture*. **74**(3-4):319-330.

Davies, I.M. and S.K. Bailey. 1991. The impact of tributyltin from large vessels on dogwhelk (*Nucella lapillus*) populations around Scottish oil ports. *Marine Environmental Research*. **32**:201-211.

de Mora, S.J. (Editor). 1996a. Tributyltin: Case Study of an Environmental Contaminant. University Press. Cambridge. UK. 301p.

de Mora S.J. and E. Pelletier. 1997. Environmental tributyltin research: Past, present, future. *Environmental Technology*. **18**:1169-1177.

Eastin, K.E. 1987. Tributyltin paint - The Navy perspective. *Sea Technology*. **28**(3):69.

Evans, D.A. and R.J. Huggett. 1991. Statistical modeling of intensive TBT monitoring data in two tidal creeks of the Chesapeake Bay. *Marine Environmental Research*. **32**(1-4):169-186.

Gibbons, T.J. 1986. Testimony of International Paint Company for the House Committee on Merchant Marine and Fisheries Hearing. In: Hearing Record. September 30, 1986. Serial No. 99-49 (65-830-0). U.S. Government Printing Office. Washington, D.C. 20402. pp. 35-60.

Gibbs, P.E., P.L. Pascoe and G.R. Burt. 1988. Sex change in the female dog-whelk, *Nucella lapillus*, induced by tributyltin from antifouling paints. *Journal Marine Biological Association (UK)*. **68**:715-731.

Gibbs, P.E., G.W. Bryan and P.L. Pascoe. 1991. TBT induced imposex in the dogwhelk, *Nucella lapillus*: Geographical uniformity of the response and effects. *Marine Environmental Research*. **32**(1-4):79-88.

Gibbs, P.E. and G.W. Bryan. 1996. Reproductive failure in the gastropod *Nucella lapillus* associated with imposex caused by tributyltin pollution: a review. In *Organotin, Environmental Fate and Effects* (M.A. Champ and P.F. Seligman, editors). Chapman and Hall. London. pp. 259-280.

Godfrey, Jr., T.W. 1999. Personal Communication. President, South Tidewater Association of Ship Repairs. Hampton Roads Virginia.

Goldberg, E.D. 1986. TBT: An experimental dilemma. *Environment*. **22**(17-20):42-44.

Grovhoug, J.G., R.L. Fransham, A.O. Valkirs and B.M. Davidson. 1996. Tributyltin concentrations in water, sediment, and bivalve tissues from San Diego Bay and Hawaiian harbors. In: Organotin: Environmental Fate and Effects. Champ and Seligman (Eds). Chapman & Hall. London. pp. 503-534

Hall, L.W. 1986. Monitoring organotin concentrations in Maryland waters of Chesapeake Bay. In: Interagency Workshop on Aquatic Monitoring and Analysis for Organotin. Published by NOAA/NMPPPO. Rockville, MD. pp. 27-28.

- Hall, L.W., M.J. Lenkevich, W.S., Hall, A.E. Pinkney and S.J. Bushong. 1986. Monitoring organotin concentrations in Maryland waters of Chesapeake Bay. *Proceedings Oceans '86 Organotin Symposium*. Marine Technology Society. Washington, D.C. Vol. 4:1275-1279.
- Hall, L.W., Jr., M.J. Lenkevich, W.S. Hall, A.E., Pinkney and S.J. Bushong. 1987. Evaluation of butyltin compounds in Maryland waters of Chesapeake Bay. *Marine Pollution Bulletin*. **18**:78-83.
- Hall, L.W. Jr., 1988 Tributyltin environmental studies in Chesapeake Bay. *Marine Pollution Bulletin*. **19**(9):431-438.
- His, E. and R. Robert. 1983-1985. Développement des véligères de *Crassostrea gigas* dans le bassin d'Arcachon. Etudes sur les mortalités larvaires. *Rev. Trav. Inst. Pêches Marit*. **47**:63-88.
- His, E. 1996. Embryogenesis and larval development in *Crassostrea gigas*: Experimental data and field observations on the effect of tributyltin compounds. Chapter 12. *In: Organotin: Environmental Fate and Effects*. Champ and Seligman (Eds). Chapman & Hall. London. pp. 239-258.
- Huggett, R.J. 1986. Monitoring tributyltin in Southern Chesapeake Bay. *In: The Proceedings of the Interagency Workshop on Aquatic Monitoring and Analysis for Organotin*. Sponsored by NOAA/NMPPPO. Rockville, MD. pp. 29-30.
- Huggett, R.J. 1987. Statement for Senate Hearing. The effects of the chemical tributyltin (TBT) on the marine environment. Hearing Record. Senate Subcommittee on Environmental Protection of the Committee on Environment and Public Works. April 29. S. HGR 100-89. U.S. Gov. Print. Office. 73-832. Washington, DC. pp. 23-28 (oral) and pp. 68-74 (written).
- Huggett, R.J., M.A. Unger and D.J. Westbrook. 1986. Organotin concentrations in southern Chesapeake Bay. *Proceedings Oceans '86 Organotin Symposium*. Marine Technology Society. Washington, D.C. Vol. 4:1262-1265.
- Huggett, R.J., M.A. Unger, P.F. Seligman and A.O. Valkirs. 1992. The marine biocide tributyltin. *Environmental Science and Technology*. **26**(2):232-237.
- Huggett, R.J., D.A. Evans, W.G. MacIntyre, M.A. Unger, P.F. Seligman and L.W. Hall. 1996. Tributyltin concentration in waters of the Chesapeake Bay. *In: Organotin: Environmental Fate and Effects*. Champ and Seligman (Eds). Chapman & Hall. London. pp.485-502.
- Key, D., R.S. Nunny, P.E. Davidson and M.A. Leonard. 1976. Abnormal shell growth in the Pacific oyster *Crassostrea gigas*. Some preliminary results from experiments undertaken in 1975. International Council for the Exploration of the Sea (ICES). Copenhagen, Denmark. CM K:11 7p.
- Maguire, R.J., Y.K. Chau, G.A. Bengert, E.J. Hale, P.T.S. Wong and O. Kramar. 1982. Occurrence of organotin compounds in Ontario lakes and rivers. *Environmental Science and Technology*. **16**:698-702.
- Maguire, R.J., R.J. Tkacz, Y./K. Chau, G.A. Bengert and P.T.S. Wong. 1986. Occurrence of organotin compounds in water and sediment in Canada. *Chemosphere*. **15**, 253-274.
- Maguire, R.J. 1996. Tributyltin in Canadian waters. *In: Organotin: Environmental Fate and Effects*. Champ and Seligman (Eds). Chapman & Hall. London. pp. 535-552.

NAVSEA (U.S. Naval Sea Systems Command) 1984. Environmental assessment of fleetwide use of organotin antifouling paint. NAVSEA. Washington, D.C. 128p.

NAVSEA (U.S. Naval Sea Systems Command). 1986. Organotin antifouling paint: U.S. Navy's needs, benefits, and ecological research. A Report to Congress. NAVSEA. Washington, D.C. 38p. + Appendix.

Proceedings of the International Organotin Symposium of the Oceans '86 Conference. 1986. Washington, D.C., Sept. 23-25. Vol. 4, pp. 1101-1330. Marine Technology Society. Washington, D.C., and the IEEE, Service Center, 445 Hoes Lane, Piscataway, N.J. 08854, U.S.A.

Proceedings of the International Organotin Symposium of the Oceans '87 Conference. 1987. Halifax, N.S., Sept. 28-Oct 1, Vol. 4, pp. 1296-1454. Marine Technology Society, Washington, D.C., and the IEEE Service Center, 445 Hoes Lane, Piscataway, N.J. 08854, U.S.A.

Proceedings of the National Organotin Symposium of the Oceans '88 Conference. 1988. Baltimore, MD, Oct. 31- Nov. 2, Vol. 4, Marine Technology Society, Washington, D.C., and the IEEE Service Center, 445 Hoes Lane, Piscataway, N.J. 08854, U.S.A.

Proceedings of the National Organotin Symposium of the Oceans '89 Conference. 1989. Seattle, WA, Sept. 18-21, Vol. 3, Marine Technology Society, Washington, D.C., and the IEEE Service Center, 445 Hoes Lane, Piscataway, N.J. 08854, U.S.A.

Proceedings of the Third International Organotin Symposium. 1990). Monaco. April 17-20. Journal of Marine Environmental Research. 1991. Special Issue on Organotin. L.D. Mee and S. W. Fowler (Guest Eds.). Vol. 32. 292p.

Reid, B. 1986. A chemical on trial. Daily Press/The Times-Herald, New Port News, VA. (Reprinted Section - Collection of Articles).

Ricketts, RDM M.V. 1987. The effects of the chemical tributyltin (TBT) on the marine environment. Hearing Record. Senate Subcommittee on Environmental Protection of the Committee on Environment and Public Works. April 29. S.HGR 100-89. U.S. Government Printing Office. 73-832, Washington, DC. pp. 28-30 (oral) and pp. 76-84 (written).

Schatzberg, P. 1987. Organotin antifouling paints and the U.S. Navy: a historical perspective. Proceedings Oceans '87 International Organotin Symposium. Marine Technology Society. Washington, D.C. Vol.4:1324-1333.

Seligman, P.F., J.G. Grovhoug, R.L. Fransham, B. Davidson, A.O. Valkirs. 1990. U.S. Navy Statutory Monitoring of Tributyltin in Selected U.S. Harbors. Annual Report: 1989. Naval Ocean Systems Center Technical Report No. 1346. Naval Ocean Systems Center, San Diego, CA. 32p.

Seligman, P.F., C.M. Adema, J.Grovhoug, R.L. Fransham, A.O Valkirs, M.O. Stallard and P.M. Stang. 1996a . Environmental loading of tributyltin from drydocks and ship hulls. *In: Organotin: Environmental Fate and Effects*. Champ and Seligman (Eds). Chapman & Hall. London. pp.405-428.

Seligman, P.F., R.J. Maguire, R.F. Lee, K.R., Hinga, A.O Valkirs and P.M. Stang. 1996b. Persistence and fate of tributyltin in aquatic ecosystems. *In: Organotin: Environmental Fate and Effects*. Champ and Seligman (Eds). Chapman & Hall. London. pp.429-458.

Svavarsson, J. and H. Skarphedinsdottir. 1995. Imposex in the dogwhelk *Nucella lapillus* (L.) in Icelandic waters. *Sarsia*. **80**, 35-40.

Ten Hallers-Tjabbes, C.C., J.F. Kemp and J.P. Boon. 1994. ImPOSEX in whelks (*Buccinum undatum*) from the open North Sea: relation to shipping traffic intensities. *Marine Pollution Bulletin*. 28:311-313.

Thain, J.E. 1983. The acute toxicity of bis (tributyl tin) oxides to the adults and larvae of some marine organisms. ICES. CM 1983/E:13. 5p.

Thain, J.E., M.J. Waldock, and M.E. Waite. 1987. Toxicity and degradation studies of tributyltin (TBT) and dibutyltin (DBTA) in the aquatic environment. Proceedings Oceans '87 International Organotin Symposium. Marine Technology Society. Washington, D.C. Vol. 4:1398-1404.

U.S. Congress. 1987a. The Senate Congressional Record dated February 2, 1987 - S1481. U.S. Government Printing Office. Washington, D.C. 20402.

U.S. Congress. 1987b. The Senate Hearing Record. for The Effects of the Chemical Tributyltin (TBT) on the Marine Environment. Committee on Environment and Public Works. U.S. Senate. April 29, 1987. S. Hrg. Serial 100-89 (73-832). U.S. Government Printing Office. Washington, D.C. 20402. 189p.

U.S. Congress. 1988. The "Antifouling Paint Control Act of 1988" The Organotin Antifouling Paint Control Act of 1988. Public Law 100-333. (33 USC 2401).

U.S. EPA (Environmental Protection Agency), Chesapeake Bay Program. 1987 Survey of tributyltin and dibutyltin concentrations at selected harbors in Chesapeake Bay - Final Report. CBP/TRS 14/87. Annapolis, MD. 58p. + Appendix 40p.

U.S. EPA (Environmental Protection Agency) 1991. Report to Congress on Environmental Monitoring of Organotin. OPTS (Office of

Pesticides and Toxic Substances). Office of Pesticide Programs. Washington, D.C. 23p.

U.S. Navy. 1986. Interim FONSI. Federal Register. Vol. 50. No. 120. p. 25748.

U.S. Navy. 1997. Navy Program to Monitor Ecological Effects of Organotin. A Report to Congress. Prepared by P.S. Seligman of Marine Environmental Support Office and Jill Bloom of the EPA Office of Prevention, Pesticides and Toxic Substances and EPA Office of Water. Sept. 1, 1997. (Commonly Referred to as the Navy Risk Assessment). 76p.

U.S. Senate. 1988. Organotin Antifouling Paint Control Act of 1987 Senate Amendments. Congressional Record - Senate. U.S. Gov. Print. Office. Washington, DC. April 18. S. 4204-4211.

Waldock, M.J. and D. Miller. 1983. The acute toxicity of bis (tributyl tin) oxides to the adults and larvae of some marine organisms. ICES CM E:13. 5p.

Waldock, M.J., J.E. Thain, and D. Miller. 1983. The accumulation and depuration of bis (tributyl tin) oxide in oysters: a comparison between the Pacific oyster (*Crassostrea gigas*) and the European flat oyster (*Ostrea edulis*). ICES CM E:52. 9p.

Waldock, M.J. 1986. Tributyltin in UK estuaries, 1982-86: Evaluation of the Environmental Problem. Proceedings Oceans '86 Organotin Symposium. Marine Technology Society. Washington, D.C. Vol.4:1324-1330.

Wolniakowski, K. Stephenson, M.D. and G. Ichikawa. 1987. Tributyltin concentrations and Pacific oyster deformations in Coos Bay, Oregon. Proceedings Oceans '87 International Organotin Symposium. Marine Technology Society. Washington, D.C. Vol.4:1438-1442.

Assessing the Degree of Appropriate Treatment of Shipyard and Drydock Wastewater Discharges and Stormwater Runoff

By

G. Fred Lee, PhD, PE, DEE and Anne Jones-Lee, PhD

G. Fred Lee & Associates, El Macero, CA

June 1999

ABSTRACT

Shipyards' and drydocks' (SYDD) wastewater discharges and stormwater runoff are currently being regulated to control the concentrations of chemical constituents in the discharges/runoff. The regulatory approach typically being used is based on worst-case assessments of the potential impacts of chemical constituents in the discharge/runoff as it may impact aquatic life in the receiving water column and sediments. This worst-case-based regulatory approach can readily lead to significant over-regulation, where SYDD are required to spend more funds in treating wastewater discharges and stormwater runoff than are necessary to protect the designated beneficial uses of the receiving waters for the discharges.

This paper presents an Evaluation Monitoring approach that will enable SYDD managers to work with regulatory agencies in assessing the appropriate degree of wastewater and stormwater treatment/management to protect designated beneficial uses of receiving waters without unnecessary expenditures. The focus of Evaluation Monitoring is on assessing the impacts of chemicals on aquatic life, and controlling these impacts in a technically valid, cost effective manner. This approach is significantly different from current regulatory approaches, which focus on chemical concentration control without regard to the aquatic chemistry/toxicology of the constituents of concern in wastewater discharges and stormwater runoff. Rather than measuring the concentrations of copper and then trying to extrapolate to aquatic life toxicity in the water column and sediments, Evaluation Monitoring focuses on using aquatic life toxicity tests to determine if the receiving waters for the wastewater discharge/stormwater runoff are toxic. If toxicity is found, the constituents responsible are identified and, through forensic studies, their source is determined.

An area of increasing concern to boatyard and drydock managers is the use of co-occurrence-based sediment quality guidelines to "assess" the water quality

significance of chemical constituents in sediments in the vicinity of their facilities' discharges. Based on co-occurrence-based "sediment quality guidelines," boatyard and drydock owners are being named as responsible parties for toxic hot spot contaminated sediment cleanup in "Superfund"-like actions. The co-occurrence-based sediment quality guidelines imply that there is a relationship between total concentrations of chemical constituents in sediments and some biological effect. However, it has been well-established for over 30 years that there is no relationship of this type, and that the total concentration of a constituent in aquatic sediments is an unreliable predictor of biological impacts.

The Evaluation Monitoring approach for assessing the water quality significance of chemical constituents in sediments focuses on determining whether there is toxicity in the sediments, and, if toxic, its cause and the source of the constituents responsible. This approach provides a far more reliable assessment of past and current wastewater discharges/stormwater runoff-associated constituent impacts on water quality than currently-used approaches.

INTRODUCTION

The development of a wastewater treatment system and stormwater runoff water quality management program from SYDD should involve a detailed evaluation of the characteristics of the receiving waters for the discharges/runoff. The current approach for regulating wastewater discharges and the evolving approach for regulating stormwater runoff from SYDD is to require that the wastewaters/stormwater not cause or significantly contribute to exceedance of a water quality standard in the receiving waters for the discharge/runoff. Such an approach can result in large expenditures to construct and operate treatment works to achieve this level of constituent control, especially if it is applied to stormwater runoff associated constituents due to the large volumes that would have to be treated during major rainfall runoff events.

DEFINITIONS - TERMINOLOGY

One of the major problems within the water quality management field is a lack of common understanding of water quality related terminology relative to regulatory requirements and appropriate evaluation of water quality. This lack of understanding, especially as it relates to developing technically valid, cost effective water pollution control programs, leads to over-regulation of wastewater discharges and stormwater runoff associated constituents for which there are water quality criteria/standards. It also leads to under-regulation of real significant water quality use impairments for the unregulated constituents for which there are no water quality criteria/standards. It is important to use such terms as pollutant, pollution, water quality, water chemistry, etc in accord with legal and technically correct usage to eliminate the inappropriate characterization of a water quality evaluation situation. The adoption of the following terminology would significantly improve the technical quality and cost effectiveness of managing water pollution.

Pollution. Pollution is defined in the Clean Water Act as an impairment of the beneficial use(s) of a waterbody. Finding chemical constituents in elevated concentrations in the water column or sediments is not pollution unless these constituents are impairing the beneficial uses of the waterbody.

Water Quality. Water Quality should be assessed based on the characteristics of the water relative to the beneficial uses of the water. Water Quality is not, as frequently used, a list of chemical constituent concentrations. In order to reliably assess whether the concentration of a constituent impairs the water quality - use impairment of a waterbody, it is necessary to evaluate on a site specific basis whether the constituent is present in toxic/available forms at a critical concentration for a sufficient duration to be significantly adverse to aquatic life that are important to the beneficial uses of the waterbody.

Water Quality Assessment. A water quality assessment is an evaluation of the beneficial use impairment that is occurring, or could potentially occur, due to the presence of a particular chemical(s) or other constituent. It is not an assessment of the frequency of exceedance of a water quality standard.

Water Quality Standard Compliance. Water Quality Standard Compliance is based on an assessment of the frequency of exceedance of a water quality standard in ambient waters receiving the discharge/runoff. Such compliance does not ensure that the beneficial use of the

waterbody is being protected or that significant over-regulation is not occurring.

Administrative Exceedance. An Administrative Exceedance of a water quality standard occurs when concentrations of a constituent are present in waters above the standard without adverse impacts to aquatic life and other beneficial uses. For example, non-toxic forms of copper are present in a waterbody above a water quality standard that is based on copper toxicity.

Excessive Bioaccumulation. Excessive Bioaccumulation of chemicals occurs when the tissue residue-body burden within edible aquatic organisms exceeds US EPA or FDA regulatory guidelines. It is not an elevated concentration of a chemical constituent relative to background or so-called "NAS" guidelines. As whole organism tissue residue guidelines are developed to protect higher trophic level fish/shellfish-eating birds and animals such guidelines may be used to evaluate excessive bioaccumulation.

Aquatic Life Adverse Impact. In order for a chemical constituent to be adverse to the beneficial uses of a waterbody, and therefore be a pollutant, it is necessary that the chemical constituent cause an altered number and/or types/characteristics of desirable forms of aquatic life.

Cause of Aquatic Life Adverse Impacts. The association of elevated concentrations of a constituent in water and/or sediments with aquatic life toxicity or altered organism assemblages is not a valid basis for assessing the cause of adverse impacts. Site specific studies involving assessing cause and effect must be used to determine if chemical constituents in water or sediments are responsible for aquatic life related adverse impacts.

Aquatic Chemistry. Aquatic Chemistry is the physical, chemical factors/reactions that control the distribution of chemical species that impact how a chemical affects water quality-beneficial uses. It includes the transport (advection and mixing) and transformations-reactions (kinetics and thermodynamics) that control the concentrations of chemical species in a waterbody.

Aquatic Chemistry is not a list of the concentrations of chemical constituents found in a water or sediment sample. Such a list is a chemical characteristic, not chemistry.

Toxic Hot Spot. A toxic hot spot should be defined as an area in which there is aquatic life toxicity that is significant to the beneficial uses of a waterbody. Further, a toxic hot spot is an area which serves as a significant source of a

bioaccumulatable chemical that is present in edible organisms at hazardous levels. A toxic hot spot should not be defined based on exceedance of a water quality standard or sediment quality guideline.

One of the designation criteria that is used in the California Water Resources Control Board's BPTCP Policy is the finding that the concentrations of constituents in a water or sediments exceed a water quality criterion/standard. With few exceptions, the water quality criteria/standards are based on worst-case assumptions. Using exceedance of a water quality criterion/standard as the basis for designating a toxic hot spot is obviously technically invalid and can lead to over-regulation.

MANAGING WASTEWATER DISCHARGES AND STORMWATER RUNOFF FROM SHIPYARDS AND DRYDOCKS

Presented below is a summary of the issues that should be considered in developing an appropriate water quality management program for wastewater discharges and/or stormwater runoff from shipyards and drydocks.

Potential Water Quality Problems

Shipyards and drydock facilities wastewaters and stormwater runoff may contain elevated concentrations of a variety of constituents that, under certain conditions, may be adverse to the beneficial uses of the receiving water for the discharge/runoff. Of particular concern are heavy metals, oil and grease, and potentially toxic organics. Many of the constituents of concern in discharges/runoff are in particulate forms and, therefore, tend to accumulate in the receiving water sediments to cause these sediments to contain elevated concentrations of potentially toxic chemical constituents. As a result, there may be need to control both dissolved and particulate forms of chemical constituents in SYDD wastewater discharges and stormwater runoff in order to protect the designated beneficial uses of the receiving waters for these discharges/runoff.

Increasing attention is being given to requiring additional treatment of wastewater discharges from industrial/commercial facilities such as SYDD beyond the normal treatment that is typically practiced. This additional treatment can represent a significant increase in cost for managing wastewater associated constituents compared to that normally being spent today to meet the traditional treatment/discharge requirements.

Potential for Over-regulation

Traditionally, wastewater discharges from SYDD are regulated in accord with NPDES permits, which establish maximum concentrations of chemical constituents which are potential pollutants based on worst-case assumptions about the impact of the constituents on the receiving waters' beneficial uses. Application of this worst-case approach to wastewater discharges typically leads to increased cost of treatment compared to that needed to protect the designated beneficial uses of the receiving waters for the wastewater discharge. For stormwater runoff from SYDD, the increase in cost can be substantial, where large amounts of funds can be spent in developing and operating treatment works for which there would be little improvement in the beneficial uses of the receiving waters for the stormwater runoff.

This paper provides guidance on an Evaluation Monitoring approach that can be used to determine, on a site specific basis, the degree of treatment of SYDD stormwater runoff that is needed to protect the designated beneficial uses of the receiving waters for this runoff. While the focus of this paper is on stormwater runoff from SYDD, the issues and approaches discussed are, in general, applicable to managing wastewater discharges from these types of facilities, with particular reference to the need for additional treatment beyond the conventional treatment that is normally required.

Evaluation of Existing Water Quality Impacts

The first step in the development of treatment works for providing additional, beyond normal, SYDD wastewater discharges and for stormwater runoff is to determine the impact of the existing discharges/runoff on the beneficial uses of the receiving waters. The mechanical comparison of the chemical concentration/characteristics of the wastewater/stormwater to worst-case-based water quality criteria/standards can lead to erroneous conclusions about adverse impacts of the constituents present in the wastewaters/stormwater above water quality standards. The US EPA (1987) Gold Book criteria, as well as the 1995 (US EPA 1996) updates of these criteria, are designed to be worst-case, which would be protective of aquatic life and other beneficial uses under essentially all conditions. There are few waterbodies where the application of worst-case-based water quality criteria as they are being implemented into discharge limits does not result in excessive treatment compared to that needed to protect beneficial uses.

Need to Incorporate Aquatic Chemistry. It is recognized that concentrations of constituents in the receiving waters

above worst-case-based water quality standards can readily occur in most waterbodies without significant adverse impacts on beneficial uses. There are situations, however, where an exceedance of a worst-case-based criterion/standard represents a significant potential threat to the beneficial uses of a waterbody. A basic problem with using US EPA water quality criteria as discharge limits includes the failure to properly incorporate the aquatic chemistry of constituents into their implementation as state standards and NPDES discharge limits. It has been well known since the 1960s that many chemical constituents exist in a variety of chemical forms, only some of which are toxic/available. Further, ambient waters and their sediments contain a wide variety of constituents which detoxify/immobilize toxic/available forms of potential pollutants such as heavy metals, organics, etc. In general, it is not possible to reliably extrapolate from a concentration of a chemical constituent measured using standard chemical analytical procedures to the concentration of toxic/available forms in the receiving water. There are a wide variety of physical, chemical and biological factors that influence this extrapolation which are rarely quantified.

While the US EPA (1995) finally took the necessary action to focus the regulation of some heavy metals in ambient waters based on dissolved forms, even dissolved forms of some heavy metals in many waters tend to over-regulate because the heavy metals interact with dissolved organic matter to form non-toxic/non-available complexes. Allen and Hansen (1996) have reviewed the importance of considering trace metal speciation in application of water quality criteria to state standards and discharge limits. The US EPA has not extended the regulations of heavy metals based on dissolved form to the many other constituents that occur in particulate or dissolved forms where the particulate forms are non-toxic and non-available. This leads to over-regulation to many organics that tend to sorb onto particulates in waterbodies.

Duration of Exposure. A key factor that is not properly incorporated into the application of US EPA water quality criteria and state standards based on these criteria is the duration of exposure that various types of organisms can experience without adverse impacts due to toxic/available forms of a constituent. The current regulatory approach involving no more than one exceedance by any amount every three years is well known to significantly over-regulate most chemical constituents in most waterbodies. It too is based on worst-case-based assumptions that are rarely experienced.

The approach that has been adopted by the US EPA of basing the water quality criteria/state standards on a one-hour average or a four-day average concentration in the water of concern is more of the conservative nature built into these

criteria/standards. The one-hour and four-day average criteria for acute and chronic criteria respectively are contrived for ease of implementation of a criteria/standard. They are not based on finding that an exceedance of a water quality criterion for acute and chronic toxicity above the criterion value necessarily represents toxic or available conditions.

Inappropriate Independent Application Policy. Yet another factor that makes the approach used for implementing US EPA water quality criteria into discharge limits is the US EPA's policy of independent application of the chemically-based criteria/standards, where these numeric values must be met even if properly conducted aquatic life toxicity tests show that the constituents of concern are in non-toxic/non-available forms. These issues were discussed by Lee and Jones-Lee (1995a). It is recognized that the appropriate approach for implementing US EPA water quality criteria involves the use of the criteria as a screen for potential adverse impacts, where the responsible parties for the discharge work with the regulatory agencies and the public in determining whether the exceedance of the criterion in a waterbody represents a real significant use impairment of the waterbody. This approach has been discussed by Lee and Jones-Lee (1995b).

Need for Site Specific Evaluation. A site specific evaluation should be conducted to determine whether a particular discharge of stormwater runoff or the residuals in a wastewater derived from SYDD are significantly impairing the beneficial uses of the receiving waters for the discharge/runoff. An Evaluation Monitoring approach (discussed below) of the type developed by the authors (Lee and Jones-Lee 1996a, 1997a, Jones-Lee and Lee 1998a) provides a technically valid, cost-effective procedure for evaluating the degree of treatment of wastewater discharges and stormwater runoff needed to protect the beneficial uses of receiving waters.

The Evaluation Monitoring approach shifts the emphasis in water quality evaluation and management from a chemical concentration based approach to a chemical impact based approach. For example, rather than focusing on the concentration of a potentially toxic heavy metal or organic and then trying to extrapolate from the concentrations measured in a wastewater discharge/stormwater runoff or ambient water, Evaluation Monitoring screens for potential toxicity in the discharge/runoff and receiving waters using a suite of toxicity tests that utilize sensitive test organisms. If a discharge/runoff and the associated receiving waters are non-toxic, then it is possible to rule out a large number of the chemical constituents which are regulated based on exceedance of worst-case-based water quality criteria and state standards.

Similarly, for constituents that tend to bioaccumulate to excessive levels in edible aquatic organisms, causing these organisms to be a threat to human health through their consumption, Evaluation Monitoring focuses on screening edible fish/shellfish to determine if excessive bioaccumulation is a real water quality problem in a waterbody. If the fish in a waterbody do not contain excessive concentrations of potentially bioaccumulatable chemicals, then it is possible to assess that the discharge of such chemicals in stormwater runoff or wastewaters does not lead to excessive bioaccumulation. If, however, excessive tissue residues are found then it is necessary to determine whether the discharge of these constituents from a SYDD is in a bioavailable form and remains in this form or converts to this form within the receiving waters for the discharge/runoff.

Similar kinds of screening approaches are used in the Evaluation Monitoring approach, where impacts of nutrients are screened based on excessive growths of algae or other aquatic plants in the receiving waters for nutrient discharges. Excessive fecal coliforms are screened through beach closures that are hydraulically connected to the discharge, etc. Lee and Jones-Lee (1997b) have provided a detailed discussion of the approaches that should be used in the implementation of the Evaluation Monitoring approach. Evaluation Monitoring is a far more technically valid, cost-effective approach for determining whether existing discharge/runoff associated constituents are significantly adversely impacting the beneficial uses of a waterbody.

SELECTING STORMWATER RUNOFF BMPS OR WASTEWATER TREATMENT APPROACHES BASED ON WATER QUALITY CONSIDERATIONS

While advanced wastewater treatment processes designed to remove specific constituents in order to achieve a desired concentration in the receiving waters are well established, the traditional hydraulic-based best management practices (stormwater runoff BMPs) design, which focuses on removal of some of the particulates in stormwater runoff, is not appropriate. As discussed by Jones-Lee and Lee (1998b), it is becoming increasingly recognized that particulate forms of heavy metals and other constituents in stormwater runoff are in non-toxic, non-available forms and therefore their removal in a conventional BMP will not necessarily improve receiving water quality-beneficial uses. The valid approach for selecting an appropriate BMP for controlling real significant water quality use impairment associated with stormwater runoff involves the following components. This same approach is applicable to

determining the degree of additional treatment needed of wastewater discharges.

Review Existing Water Quality Characteristic Data for the Stormwater Runoff/Wastewater Discharges and the Receiving Waters

- Determine if there is an exceedance of a receiving water quality standard that is caused or contributed to by the stormwater runoff or wastewater discharged by SYDD.
- Determine if a real water quality use impairment (pollution) of the receiving water is occurring in the receiving waters for the stormwater runoff/wastewater discharge that is due to constituents in the stormwater runoff/wastewater discharge. The purpose of this effort is to determine if the stormwater runoff/wastewater discharge is causing or significantly contributing to real pollution of the receiving waters for the stormwater runoff. This will assess whether the exceedance of the water quality standard is an administrative exceedance relative to the highly protective nature of worst-case-based water quality criteria/standards when applied to many constituents in most waterbodies.

- If an inadequate database exists to determine if a violation of a water quality standard or a receiving water use impairment is occurring, then initiate a water quality monitoring/evaluation program designed to evaluate whether a real significant water quality use impairment is occurring in the stormwater runoff's receiving waters. Use the Evaluation Monitoring approach in evaluating whether a real significant water quality problem exists in the receiving waters for the runoff.

Addressing Administrative Exceedances of Water Quality Standards

- If a water quality standard violation occurs without a significant use impairment of the receiving waters, then petition the regulatory agencies for a variance from having to meet water quality standards in the runoff/wastewater receiving waters based on there being no use impairment occurring in the receiving waters due to the stormwater runoff associated constituents. This effort will enable stormwater runoff/ wastewater discharge water quality managers to reveal and appropriately address the over-regulation that arises from the US EPA's Independent Applicability Policy and the use of worst-case-based water quality criteria/standards.

This variance should include the opportunity to adjust the receiving water standards/stormwater discharge limits and/or the designated uses of the receiving waters to protect the designated beneficial uses of receiving waters for the

stormwater runoff without significant unnecessary expenditures for chemical constituent control. These adjustments should be based on appropriately conducted receiving water studies that focus on assessing chemical impacts, rather than the traditional approach of measuring chemical concentrations and loads. The US EPA (1994), in their Water Quality Standards Handbook provides guidance on how the worst-case-based water quality criteria can be adjusted for site specific conditions. It is important to understand, however, that the Agency's approach for developing site specific criteria/standards can still lead to over-regulation since it does not fully account for the aqueous environmental chemistry of constituents as they may impact the beneficial uses of a waterbody.

Determining the Cause of the Pollution and the Source of the Pollutant

- If a water quality use impairment is found in the receiving waters for the stormwater runoff/wastewater discharge, determine the specific causes of the use impairment and, through forensic studies, whether the toxic/available form of the specific constituent(s) responsible for the use impairment is derived from the stormwater runoff/wastewater discharge of concern. Also determine the relative significance of the stormwater runoff/wastewater discharge versus other sources of the specific constituents responsible for the use impairment as a cause of the use impairment. The relative contribution information is needed to evaluate the potential improvement in the receiving water water quality as a result of implementation of the proposed BMPs/ advanced wastewater treatment.

Selection and Economic Evaluation of BMPs

- Select a BMP(s)/treatment processes to control the specific constituents responsible for the use impairment. The BMP/ treatment process selection should be based on the specific chemical species that cause a water quality use impairment in the receiving waters rather than the total concentrations of the constituent. For example, focus the BMP on removing those forms of dissolved copper that are significantly adverse to beneficial uses in the receiving waters for the runoff rather than on total copper, much of which is in the non-toxic form.

Evaluate Cost Effectiveness of a BMP(s) in Controlling Significant Pollution

- If the development and operation of the proposed stormwater runoff BMP/wastewater treatment process appears to be economically feasible, then estimate the potential improvement in the designated beneficial uses that will occur relative to the unregulated or under-regulated

sources of the same pollutant(s) responsible for the use impairment.

- If the potential improvements in the receiving water's designated beneficial uses is limited compared to projected costs to eliminate the use impairment, then the community leaders, regulatory agencies, environmental groups and public groups that are interested in appropriate use of funds should be consulted to evaluate if the expenditures for stormwater runoff/wastewater treatment chemical constituent control is the best use of the funds potentially available to meet societal needs.

Evaluate the Efficacy of the BMP/Treatment Processes

- Evaluate the efficacy of the stormwater runoff BMP/ wastewater treatment processes in controlling existing use impairments as well as preventing new use impairments. The traditional approach of measuring the removal of a chemical constituent(s) across a structural BMP such as a filter, detention basin, etc. as well as wastewater treatment works does not evaluate whether the BMP/treatment process causes an improvement in the receiving water's impaired uses. BMP/treatment process efficacy evaluations must be based on evaluating the improvements that the BMP/ treatment process causes or, for new developments, is expected to cause in the receiving water beneficial uses. This will require site specific studies of the impact of the development and operation of the BMP/treatment works on the receiving waters' beneficial uses for the treated discharge.

Detection of Future Stormwater Runoff Water Quality Problems

- Develop an ongoing monitoring/evaluation program to search for subtle and new water quality use impairments. An important component of a properly developed and implemented stormwater runoff water quality management program is the funding of a stakeholder consensus-based monitoring/evaluation program to detect subtle water quality problems that were not detected in the initial search for real significant water quality use impairments. This program should be designed to detect new water quality use impairments that arise from the use of new or expanded-use chemicals that become part of stormwater runoff or wastewater discharges. The search for undetected and new problems should be repeated every five years to coincide with the NPDES permit cycle.

Watershed-Based Approach

- The stormwater runoff BMP selection and wastewater treatment plant facilities upgrading should be formulated/

implemented on a watershed-based water quality management program in which the stakeholders for the management of the stormwater runoff/wastewater discharge water quality and the beneficial uses of the receiving waters and downstream waters for the stormwater runoff/wastewater discharge that could be impacted by the runoff, work together in a consensus-based approach to formulate, implement and evaluate the stormwater runoff water quality management program.

Managing Contaminated Sediment Quality Issues

The aquatic sediments near SYDD often contain elevated and sometimes greatly elevated concentrations of a variety of chemical constituents that are potential pollutants that have been derived, at least in part, from wastewater discharges/stormwater runoff from SYDD. Increasing regulatory attention is being given at the federal and state level to managing the water quality impacts of chemical constituents in aquatic sediments. This is leading to the development of an aquatic "Superfund" - aquafund-like programs in which responsible parties are being designated to pay for contaminated sediment remediation. Further, the NPDES wastewater and/or stormwater discharge permits for suspected sources of the constituents that are present in the sediments at elevated concentrations are being modified to reduce the input of the associated constituents. The California Water Resources Control Board (WRCB 1998) has recently adopted the Bay Protection and Toxic Hot Spot Cleanup Program Policy that implements a California aquatic sediment aquafund. Lee and Jones-Lee (1998b) have discussed the significant technical problems with the BPTCP toxic hot spot cleanup Policy. This Policy, as adopted, will lead to inappropriate designation of toxic hot spots and the naming of PRPs for their remediation.

As discussed by Lee and Jones-Lee (1998a), there are situations where the discharge of hazardous chemicals in wastewaters and stormwater runoff to waterbodies causes significant water quality use impairments associated with elevated concentrations of chemical constituents in aquatic sediments. There are also many situations where elevated concentrations of chemical constituents in aquatic sediments that are potential pollutants such as heavy metals do not cause an impairment of a waterbody's beneficial uses. Because of the great cost of "superfund" aquatic sediment remediation programs, it is important to properly evaluate whether an elevated concentration of a chemical constituent in aquatic sediments represents a real significant use impairment that would justify the remediation of the sediments to remove the constituents that are causing the elevated concentrations.

Reliable Evaluation of the Water Quality Significance of Chemical Constituents in Aquatic Sediments

There is considerable misinformation on how to reliably evaluate whether a chemical constituent or group of constituents present in an aquatic sediment are significantly impairing the beneficial uses of the waterbody in which the sediments are located. There are basically two approaches being advocated. One of these is a chemical concentration approach in which an elevated concentration of a chemical constituent that at some locations and under certain conditions is in a form that is adverse to the organism assemblages present within or on the sediments. The other is a biological effects based approach which focuses on measuring chemical impacts rather than chemical concentrations.

There are situations where constituents in sediments that are of concern because of their potential to bioaccumulate to excessive levels in higher trophic level edible organisms (fish and shellfish) serve as important sources of hazardous chemicals in fish that are used as food. There are also situations where the elevated concentrations of potentially toxic or bioaccumulatable chemicals in sediments are in non-toxic non-bioavailable forms. It is well established since the 1960's that there is no relationship between the concentrations of chemical constituents in sediments and their toxicity/availability for bioaccumulation. As discussed by Lee and Jones (1992), Lee and Jones-Lee (1993a) and Lee and Jones-Lee (1996b) the toxicity/availability of chemical constituents in aquatic sediments is determined by the concentration of many of the bulk parameters of the sediments such as TOC, sulfides, carbonates, clays, iron and aluminum oxides, etc. that interact with the potential pollutants to cause them to be non-toxic.

Some regulatory agencies at the federal and state level such as the US EPA (Keating 1998), have adopted or are in the process of adopting sediment quality guidelines based on co-occurrence based approaches, it is obvious that since this approach involves relating the total concentration of a chemical constituent in sediments to a water quality impact, that co-occurrence based guidelines are technically invalid. Lee and Jones-Lee (1993a,b,c, 1996b), as well as many others such as O'Connor (1999a,b) have discussed the unreliability of co-occurrence based guidelines. O'Connor (1999a) based on a critical review of the NOAA and US EPA data concluded, "*All these criteria are better than random selections in identifying toxic sediment but they are not reliable. They are all more often wrong than right and should not be used, by themselves, to imply anything*

about biological significance of chemical data.” Co-occurrence of sediment based guidelines are unreliable and should not be used even as screening values to infer that a concentration of a chemical constituent in aquatic sediments is responsible for any water quality impacts that may be associated with those sediments. Such an association can readily lead to erroneous conclusions on the chemicals responsible for aquatic life toxicity and the sources of those constituents.

Suggested Approach. The approach that can be followed in evaluating whether elevated concentrations of a chemical constituent represents a potential cause of water quality impairment include the following.

Aquatic Life Toxicity

- Determine if the sediments are toxic using several sensitive test organisms and several appropriate toxicity test reference sites.

Conduct toxicity tests at at least three sites in the area of concern quarterly for a year.

- If the sediments are toxic, determine if the aquatic life assemblages associated with the toxic sediments are significantly different from those present in the reference areas as well as nearby apparently less impacted sediments than those of primary concern.

Determine if there is an aquatic organism assemblage gradient that is apparently related to toxicity in the sediments of concern.

- If there is a significant aquatic organism assemblage gradient that persists over a year that is apparently related to toxicity of the sediments of concern, evaluate the water quality significance of this toxicity. Also evaluate the potential improvement in the designated beneficial uses of the waterbody if the toxic sediments were remediated.

It is important to note that this evaluation program has not thus far included any attempt to determine the cause of the sediment toxicity

- Reliably evaluate the potential cost of sediment remediation.
- If sediment toxicity appears to be a significant cause of a water quality use impairment and it appears to be economically feasible to remediate the contaminated sediments to eliminate the sediment toxicity, then proceed with evaluation of the cause of sediment toxicity.

Conduct sediment chemistry/toxicity investigations (sediment TIE's) to determine the constituents that are in the sediments that are responsible for the toxicity.

Do not use co-occurrence based sediment quality guidelines to “associate” the presence of chemical constituents in aquatic sediments that are toxic to aquatic life that cause significantly altered organism assemblages.

Excessive Bioaccumulation

- Determine if edible fish/shellfish from the waterbody preferably in the area of concern contain excessive concentrations of potentially hazardous chemicals that would cause the use of these fish as food to be a threat to human health. US EPA (1997) provides guidance on conducting bioaccumulation investigations.

Use a human health based guideline consumption rate of one meal of local fish per week. Evaluate if this consumption rate is appropriate for local populations that are consuming the fish from the waterbody of concern.

- Determine the chemical characteristics of the sediments twice per year (late spring and fall).

Determine the concentrations of the suite of heavy metals, PAH's, chlorinated hydrocarbon pesticides, PCB's and dioxins. Analyze the sediments for those chemical constituents that have been found to be present in excessive concentrations in edible fish taken from the waterbody.

If the sediments of concern contain elevated concentrations of constituents that have accumulated in edible aquatic life tissue to cause the use of the aquatic life as food to be considered a threat to human health, utilize the US EPA/COE (1991, 1998) procedures to assess the bioavailability of the constituents of concern in the sediments. Also, measure the tissue concentrations of benthic invertebrates taken from the sediments of concern to determine if they have elevated concentrations of mercury for those situations where mercury has bioaccumulated to excessive levels in fish within the waterbody.

This information should be used to determine whether the elevated concentrations of chemical constituents that are potentially bioaccumulatable in a sediment that are contributing to the excessive bioaccumulation problem within organisms taken from the waterbody in which the sediments are located.

Forensic Source Studies

In order to control the development of future contaminated sediments and, for that matter, water column toxicity/ bioaccumulation problems, it is necessary to reliably define the source(s) of the constituents that have been and/ or could be causing water quality problems. In some situations this is relatively obvious, in that there is a single discharger, such as a boat yard or a drydock, that is isolated from all other sources of the same types of constituents of concern responsible for the sediment or water column toxicity or excessive bioaccumulation. However, in many situations, such as in bays or in major urban industrial areas, there will be multiple discharges/sources of the same general types of constituents that are causing the water quality problem. Under these conditions it is necessary to conduct a reliable forensic study to determine the specific source(s) of the specific constituent(s) responsible for the adverse impact on water quality.

This type of study should not follow the approach recommended by the California Water Resources Control Board (WRCB 1998) in their Bay Protection and Toxic Cleanup Program (BPTCP) Toxic Hot Spot Policy of using elevated concentrations of constituents in the sediments to define the constituent(s) responsible for the toxic hot spot (toxicity source or source of the bioaccumulatable chemicals) in which a source of the elevated concentrations of the constituents is any discharger that has the same constituents in the discharge as were "associated" with the toxic hot spot. Such an approach is obviously technically invalid in that it ignores the aqueous environmental chemistry of chemical constituents that controls the toxic/ available forms of potential pollutants.

It is well understood by those with an elementary knowledge of aquatic chemistry/toxicology that all copper from all sources in all waterbodies is not equally toxic. The same situation applied to many other constituents. While tentative sources of potential pollutants can be identified through association based on elevated concentrations, detailed site specific investigations must be conducted to confirm that a potential source is in fact a real source of pollutants whose NPDES permit or waste discharge limits should be modified to control the input of pollutants.

These forensic studies must include detailed consideration of the aqueous environmental chemistry of the constituents of concern within the waterbodies of concern to determine whether a particular discharge of a potential pollutant of concern is toxic/bioavailable at the discharge and/ or converts to toxic/bioavailable forms within the receiving waters for the discharge that accumulate/are

present at sufficient concentrations to cause a water quality use impairment at the point of concern.

When there are multiple sources of potentially significant constituents, then an attempt to quantify the relative contributions of each source should be made. Again, this should not be done based on a total concentration mass load approach. As discussed by Lee and Jones (1996d), it should be based on a site specific evaluation of the aqueous environmental chemistry/toxicology of the constituents derived from each source.

Funding of Site Specific Evaluation

While some potential dischargers of chemical constituents that could be adverse to the beneficial uses of a waterbody assert that it is the responsibility of the regulatory agency to prove that their discharge has or is, in fact, causing pollution-impairment of the beneficial uses of a waterbody, the burden of proof for water pollution control is on the discharger rather than the impacted public/regulatory agencies. However, in adopting this approach it is incumbent on the regulatory agencies to carefully specify the conditions under which potential polluters are designated. Approaches such as those adopted by the California Water Resources Control Board in its BPTCP Policy (WRCB 1998), in which "association" of elevated concentration of chemical constituents is used to designate a toxic hot spot, should be considered technically invalid since they can lead to frivolous designation of pollutants and/ or responsible parties for contaminated sediment cleanup and NPDES permit modification.

It is important to understand that the adversarial regulatory system that exists today cannot tolerate frivolous designation of toxic hot spots. There are a number of examples where inappropriate designation of pollutants in sediments have been made using co-occurrence-based approaches that cause the public to have to spend large amounts of funds cleaning up contaminated sediments under conditions where this expenditure will not result in an improvement of the beneficial uses of a waterbody. This type of situation has been discussed by Lee and Jones-Lee (1993b).

The implementation of the incorporation of higher quality science and engineering into water quality management will require a substantial increase in site specific evaluations compared to the approach that is being used today to develop regulatory requirements for a particular discharge/runoff. In order to ensure that the funds needed to properly implement this more enlightened, technically valid approach are made available by the

discharger, the discharger should be given the option of either complying with worst-case-based chemical constituent control or complying with an appropriate assessment of the real impacts that chemical constituents in discharges/runoff have on the beneficial uses of a waterbody. Adoption of this approach would encourage dischargers, both public and private, to invest in appropriately conducted, watershed-based, stakeholder consensus developed receiving water evaluations in order to improve the cost effectiveness of expenditures for water pollution control.

A Technically Valid Water Quality Management Approach - A Water Quality Triad

There is growing recognition that the current water quality regulatory approach, in which a single exceedance by any amount of a constituent for which there is a water quality standard more than once every three years, is a technically invalid approach for cost-effective water pollution control. The US EPA, as part of adopting this chemical concentration based approach in the early 1980s, opted for a bureaucratic simple to administer but obviously, then and today, technically invalid approach.

While the Agency management staff claim that this approach is highly successful, in fact, as discussed herein, it is strongly contrary to the public's interests. In order to avoid massive waste of public and private funds chasing ghosts of problems associated with exceedance of a worst-case-based water quality criterion/standard, there is need to elevate the quality of science and engineering to the current level of understanding of how chemical constituents impact aquatic life and other beneficial uses of waterbodies.

The water quality triad approach is evolving as a regulatory approach in which the current science and engineering can be incorporated into defining a real significant water quality use impairment and the approach that should be used for its control/remediation. A water quality triad evaluation of potential beneficial use impairments of a waterbody is based on a non-numeric, best professional judgement, integrated assessment of information on aquatic organism assemblages, toxicity, bioaccumulation and chemical information. It involves determination of the numbers, types and characteristics of aquatic life present in a waterbody relative to the habitat characteristics. It also involves an assessment of aquatic life toxicity to a suite of sensitive test organisms relative to appropriate reference controls, as well as the use of chemical techniques (toxicity investigation evaluations) to determine, through toxicity assessments on the fractionated sample, the chemical constituents responsible for aquatic life toxicity.

The water quality triad should be implemented through a panel of experts in the topic area of concern, where this panel critically evaluates the adequacy of the current data/information base in defining a real significant water quality use impairment and the cause/source of the constituents responsible for the use impairment. If an inadequate database is available for a reliable evaluation, then the discharger(s) would work with the regulatory agencies and the public to develop the additional information needed. When this information is available it would be critically reviewed by the triad expert panel and a decision would be rendered by the panel on the magnitude of the water quality problem that exists, its significance to the public's interests and approaches with associated costs for its control/remediation. This information would then be used by the regulatory agency to implement a technically valid, cost-effective water quality management program.

Addressing Disagreements Among Experts

The current regulatory approach is largely based on an adversarial approach, where proponents (dischargers, regulatory agencies, environmental groups, etc.) of a particular position support their position without discussing the technical weakness of the position. If those in opposition to the position have adequate funding, they will hire consultants who will support their position. The regulatory board, which is typically composed primarily of lay members of the public, as well as the courts, are faced with trying to evaluate the technical merits of complex topics where there are what appears to them equal and opposite views/conclusions on issues. This situation frequently results in regulatory decisions being made which largely ignore current science and engineering that should be used to formulate public policy on a water quality management issue.

It is recommended that a public interactive peer review of technical issues be conducted in order to resolve disagreements among experts, including the water quality triad panel members, on complex technical issues. By adopting a public interactive peer review process anyone who peer reviews a topic must be prepared to defend these reviews in a public arena where those who find that the reviews are inadequate have the opportunity to point out the inadequacies of these reviews under a situation where the review board has the opportunity to hear an exchange of discussion of issues and receive written documentation with appropriate references in support of positions by the parties involved.

The peer review should not be conducted by a single individual but should involve the development of a peer review panel consisting of at least three knowledgeable individuals. The selection of the peer reviewers for the peer review panel should be a public process where the peer reviewers are knowledgeable and will take the time to fully review the pertinent information on the topic. They should review not only the regulatory board staff's discussion on issues, but also the comments made by others on the lack of validity of the staff's approach as well as those of the project proponents and others who commented on the issues.

The peer review panel should present the preliminary results of their reviews in a public meeting where the public has the opportunity to question and comment on the adequacy of the review. The reviewers then should be given the opportunity to make revisions in their review based on any new information obtained and develop a final review which is then submitted to the Board where again the public would have the opportunity to comment on its adequacy.

SUMMARY

The stormwater runoff BMP/improved wastewater treatment process development approach recommended herein is designed to transform the development of stormwater runoff BMPs from the current obviously technically invalid, non-cost effective traditional approach to one that incorporates mid-1990s science and engineering information into water quality management. Adoption of this approach will enable stormwater runoff water quality managers to select, implement and properly evaluate the efficacy of stormwater runoff water quality BMPs that will cost-effectively address real water quality use impairments in the receiving waters for the runoff in a technically valid manner. It will also enable those responsible for managing public funds to do so in a technically valid, cost-effective manner.

Additional Information

Additional information on these issues is available in the references listed below as well as in papers and reports developed by the authors that are available as downloadable files at the authors' web site, www.gfredlee.com. These publications contain references to the work of others that is pertinent to the topics discussed.

REFERENCES

Allen, H.E. and Hansen, D.J., "The Importance of Trace Metal Speciation to Water Quality Criteria", *Water Environment Research*, 68:42-54, (1996).

Jones-Lee, A. and Lee, G.F., "Evaluation Monitoring as an Alternative to Conventional Water Quality Monitoring for Water Quality Characterization/Management," Proc. of the NWQMC National Conference *Monitoring: Critical Foundations to Protect Our Waters*, US Environmental Protection Agency, Washington, D.C., pp. 499-512, (1998a).

Jones-Lee, A. and Lee, G.F., "Stormwater Managers Beware of Snake-Oil BMPs for Water Quality Management," Report of G. Fred Lee and Associates, El Macero, CA, July (1998b). Available from www.gfredlee.com.

Keating, J., "Use of Sediment Chemistry and Toxicity Tests to Interpret Narrative Standards for Sediment Quality," Presented at US EPA Meeting on Water Quality Standards, Water Quality Criteria and Implementation, Including Water Quality-Based Permitting, Philadelphia, PA, August (1998).

Lee, G.F. and Jones, R.A., "Water Quality Aspects of Dredging and Dredged Sediment Disposal," In: Handbook of Dredging Engineering, McGraw Hill pp. 9-23 to 9-59, (1992). An updated version of this chapter which will appear in the second edition of this handbook is available from www.gfredlee.com. (1996)

Lee, G.F. and Jones-Lee, A., "Sediment Quality Criteria: Numeric Chemical- vs. Biological Effects-Based Approaches," Proc. Water Environment Federation National Conference, Surface Water Quality & Ecology, pp. 389-400, (1993a).

Lee, G.F. and Jones-Lee, A., "Equilibrium Partitioning-Based Values: Are They Reliable for Screening Contaminated Sediment?" Letter to the editor of *Environ. Sci. & Technol.*, 27:994 (1993b).

Lee, G.F. and Jones-Lee, A., "Contaminated Dredged Sediment Disposal Criteria," Proc. ASCE "Dredged 94" Second International Conference on Dredging and Dredged Materials Placement, Orlando, FL, pp. 121-130, (1994).

Lee, G.F. and Jones-Lee, A., "Independent Applicability of Chemical and Biological Criteria/Standards and Effluent Toxicity Testing," *The National Environmental Journal*, 5(1):60-63, (1995a), Part II, "An Alternative Approach," 5(2):66-67 (1995a).

Lee, G.F. and Jones-Lee, A., "Appropriate Use of Numeric Chemical Water Quality Criteria," *Health and Ecological Risk Assessment*, 1: 5-11, (1995b). Letter to the Editor, Supplemental Discussion, 1996. 2: 233-234.

Lee, G.F. and Jones-Lee, A., "Assessing Water Quality Impacts of Stormwater Runoff," North American Water & Environment Congress, Published on CD-ROM, Amer. Soc. Civil Engr., New York, NY, (1996a). Available at: www.gfredlee.com.

Lee, G.F. and Jones-Lee, A., "Evaluation of the Water Quality Significance of the Chemical Constituents in Aquatic Sediments: Coupling Sediment Quality Evaluation Results to Significant Water Quality Impacts," In: WEFTEC '96, Surface Water Quality and Ecology I & II, Vol 4, pp. 317-328, Proc. Water Environ. Fed. Annual Conference, (1996b).

Lee, G.F. and Jones-Lee, A., "'Co-Occurrence' in Sediment Quality Assessment," Report of G. Fred Lee & Associates, El Macero, CA, 16 pp, (1996c). Available from www.gfredlee.com.

Lee, G.F. and Jones-Lee, A., "Aquatic Chemistry/Toxicology in Watershed-Based Water Quality Management Programs," In: Proc. Watershed '96 National Conference on Watershed Management, Water Environment Federation, Alexandria, VA, pp. 1003-1006 (1996d).

Lee, G.F. and Jones-Lee, A. "Evaluation Monitoring as an Alternative to Conventional Stormwater Runoff Monitoring and BMP Development," *SETAC News*, Vol 17. No. 2, pp. #20-21, (1997a).

Lee, G.F. and Jones-Lee, A., "Development and Implementation of Evaluation Monitoring for Stormwater Runoff Water Quality Impact Assessment and Management," Report of G. Fred Lee & Associates, El Macero, CA, June (1997b). Available from www.gfredlee.com.

Lee, G.F. and Jones-Lee, A., "Stormwater Runoff Water Quality Evaluation and Management Program for Hazardous Chemical Sites: Development Issues," *Superfund Risk Assessment in Soil Contamination Studies: Third Volume, ASTM STP 1338*, American Society for Testing and Materials, pp. 84-98, (1998a).

Lee, G.F. and Jones-Lee, A., "Comments on 'Draft Functional Equivalent Document Water Quality Control Policy for Guidance on the Development of Regional Toxic Hot Spot Cleanup Plans' Developed by Division of Water Quality, State Water Resources Control Board, March 1998," Submitted to the State Water Quality Resources Control Board, G. Fred Lee & Associates, El Macero, CA, May (1998b). Available from www.gfredlee.com.

O'Connor, T.P., "Sediment Quality Guidelines Do Not Guide," *Learned Discourses: Timely Scientific Opinions*, SETAC News, January (1999a).

O'Connor, T.P., "Sediment Quality Guidelines Reply-to-Reply," *Learned Discourses: Timely Scientific Opinions*, SETAC News, May (1999b).

US EPA, "Quality Criteria for Water 1986," EPA 440/5-86-001, US Environmental Protection Agency, Office of Water Regulations and Standards, Washington, D.C., (1987).

US EPA, "National Pollutant Discharge Elimination System Permit Application Regulations for Stormwater Discharges; Final Rule," US Environmental Protection Agency, 40 CFR Parts 122, 123, and 124, *Federal Register* 55(222):47990-48091, November 16 (1990).

US. EPA, "Water Quality Standards Handbook: Second Edition", U.S. Environmental Protection Agency, Office of Water EPA-823-B-94-005, Washington, D.C. (1994).

US EPA, "Stay of Federal Water Quality Criteria for Metals; Water Quality Standards; Establishment of Numeric Criteria for Priority Toxic Pollutants; States' Compliance—Revision of Metals Criteria; Final Rules," *Federal Register*, 60(86): 22228-22237, (1995).

US EPA, "1995 Updates: Water Quality Criteria Documents for the Protection of Aquatic Life in Ambient Water," US Environmental Protection Agency, Office of Water 4301 EPA-820-B-96-001 Washington D.C., September (1996).

US EPA, "Guidance for Assessing Chemical Contaminant Data for Use in Fish Advisories," Vol. II, Risk Assessment and Fish Consumption Limits, Second Edition, EPA 823-B-97-004, U.S. Environmental Protection Agency, Office of Water, Washington, D.C. (1997).

US EPA/US COE, "Evaluation of Dredged Material Proposed for Ocean Disposal-Testing Manual," US Environmental Protection Agency, Office of Water, EPA-503/8-91/001, Washington, D.C., (1991).

US EPA and US Army Corps of Engineers, "Evaluation of Dredged Material Proposed for Discharge in Waters of the U.S. - Testing Manual," Office of Water, EPA-823-B-98-004, Washington, D.C., February (1998).

WRCB, "Water Quality Control Policy for Guidance on Development of Regional Toxic Hot Spot Cleanup Plans," CA Water Resources Control Board, Sacramento, CA, September (1998).

Advanced Technologies for Removing TBT from Ship Washdown and Drydock Runoff Wastewaters

Thomas J. Fox¹, Thomas Beacham² Gary C. Schafran³, and Michael A. Champ⁴

ABSTRACT

Since July of 1999, with funding from the U.S. EPA, the State of Virginia, and a consortium of shipyards in the Norfolk, Virginia area, an extensive international search has been conducted to find or develop a treatment method or system to remove from TBT from ship hull washdown wastewaters that would normally be discharged to local water ways or to sewage treatment systems. The purpose of this research, development and demonstration project has been to achieve a reduction in wastewaters discharged from shipyards and drydocks that range from several thousand to several hundred thousand parts-per-million (ng/L) to less than 50 ng/L to protect marine resources in Chesapeake Bay.

Keywords:

Tributyltin (TBT), Discharges, NPDES Permit, Virginia DEQ, Shipyard Wastewaters, Advanced Waste Treatment, Carbon, DAF.

INTRODUCTION

TBT is highly toxic to some aquatic organisms at concentration levels measured in parts-per-trillion (ng/L). While it is used in a wide variety of industrial and commercial products, of most concern is its use in antifouling paints for ship hulls. Tributyltin was introduced as a biocide in antifouling paints over 30 years ago. It is said to be the most toxic material ever introduced deliberately by mankind into the marine environment.

In 1997, after 10 years of study, the United States Environmental Protection Agency proposed a national saltwater aquatic life criterion for TBT of 10 ng/L (62 CFR 42554, August 7, 1997). The Commonwealth of Virginia led the nation in developing a TBT standard, establishing in 1987, a surface water standard of just 1 ng/L and an NPDES discharge standard of 50 parts-per-trillion (ng/L). Virginia is the only state in the nation with a discharge standard for TBT. Some Virginia shipyards now operate under Consent Order deadlines, which mandate compliance with the 50 ng/L discharge limit by December 2001.

¹ Executive Director, Center for Advanced Ship Repair and Maintenance (CASRM), Norfolk, VA, Tel. (757) 622-2137, Fax (757) 622-2490, E-Mail: casrm@infi.net

² Environmental Manager, Lyons Shipyard, PO Box 2180, Norfolk, VA 23501, Tel. 757-622-4661, Fax. 757-623-4751, E-Mail: tbea835062@aol.com

³ Associate Professor, Old Dominion University, Civil Engineering, Kaufman Engineering Hall, Room 130, Norfolk, VA 23529, Tel. 757-683-4673, Fax. 757-683-5354, gschafra@odu.edu

⁴ President and CEO, Advanced Technology Research Project Corporation, P.O. Box 2439, Falls Church, VA 22042, Tel. (703) 237-0505, Fax (703) 241-1278, E-Mail: machamp@aol.com

The adoption of this standard has had a major impact on the Virginia ship repair industry. Shipyards generate TBT water from wash-down operations in dry-docks where fresh water is used to remove salt and slime from ship's hulls. This operation must be performed on all dry-docked ships. TBT levels in process waters from ship wash-down have been observed to be approximately 10,000 times higher than the new Virginia discharge standard. TBT is also generated from repair operations on sonar domes of US Navy surface combat ships.

This paper describes efforts by the Virginia ship repair industry to achieve compliance with the 50 ng/L discharge limit.

BACKGROUND

Between 70 and 75% of the 27,000 deep water commercial ships have hulls coated with an antifouling paint containing TBT. These paints are used because they are extremely effective for preventing marine growth on the hulls, which can reduce ship speed and increase fuel costs. TBT is highly toxic to aquatic life at very low concentrations measured in parts-per-trillion (ng/L), see Champ and Seligman (1996).

The largest source of TBT in coastal US marine waters is that leached from the hulls of the thousands of ships which visit the US ports each year to load and unload cargo. This discharge is designated as non-point source and is unregulated in the United States.

A second and lesser source (but is a point source) of TBT from ships to the marine environment is when ships are dry-docked for standard hull inspection and certification (for insurance purposes) and or repair. The first operation in dry-dock is to wash down hoses the hull with high-pressure fresh water in order to remove marine salt and slime. This operation must be done to permit inspection of the hull and coatings, and in

preparation for any hull repair work. A typical wash down job may generate over 100,000 gallons of wash wastewater, containing varying amounts of TBT from several thousand to several hundred thousand parts-per-trillion.

Virginia is the first state in the country to incorporate a numerical TBT limit for Virginia Pollution Discharge Control System (VPDES) shipyard permits. A consent order has been signed between the parties (DEQ, EPA and Shipyards) involved to meet a deadline of December 1, 2001 for Virginia shipyards for compliance with discharging water containing less than 50 ng/L of TBT. However, Newport News Shipbuilding has in its permit, compliance by June 4th, 2000.

Removing pollutants from industrial waste streams is fairly straightforward at levels of parts per million, It is much more difficult and expensive at levels of parts per billion. Purifying large quantities of water to levels of parts per trillion is a major technical challenge. At present, shipyards have no practical guidance on any technology that can be employed to meet regulatory discharge limits.

Over a period of 40 years, TBT has been the subject of many hundreds of studies that have documented the effects of TBT on different marine organisms (in different bodies of water). The effects of pH, water temperature, salinity and seasons of the year have been measured, as have the rate of decay of TBT in the environment, the fate of TBT in sediments, etc. Four international Symposia have been held related to fate and effects of TBT in the marine environment and a reference work has been published from some 40 years of studies (Champ and Seligman, 1996).

Notably missing from this body of knowledge is any work relating to the removal of TBT from industrial waste streams. There are a small number of papers relating to the fate of TBT in municipal wastewater plants using activated sludge (Fent 1996), but this involved low concentrations of TBT

(200 ng/L) in the influent water stream. Industrial waste streams from shipyards have measured TBT levels as high as 480,000 ng/L, which is known to be sufficient to kill the bacteria in activated sludge (Argaman *et al*, 1984). Additionally, water from dry-dock wash-down operations is intermittently generated, which rules out biological processes as a viable treatment option.

There is very little published information concerning the treatment of TBT in wastewater. Shipyards have no guidance on how to treat their water to remove TBT.

VIRGINIA SHIPYARDS' APPROACH TO ACHIEVING TBT COMPLIANCE

Virginia shipyards elected to work together cooperatively to address the TBT compliance challenge. Several years ago the shipyards helped establish the Center for Advanced Ship Repair and Maintenance (CASRM) as a cooperative partnership between the industry and the College of Engineering and Technology at Old Dominion University, Norfolk, VA. The CASRM consortium has since coordinated most of the shipyards TBT research, development and demonstration projects.

CASRM first commissioned a global bibliography of scientific papers (Alden *et al.*, 1996) dealing with the adverse ecological effects of TBT. This bibliography detailed over 600 different scientific studies that defined the extent of the problem; however, there was virtually no information in the published work that could give guidance to shipyards on how to treat TBT in wash down wastewaters.

In 1997, CASRM began a project to determine the state-of-the-art technological practices regarding the reduction of TBT concentrations in wastewater (Messing *et al*, 1997). The National Shipbuilding Research Program (NSRP) funded this project. A survey was made of shipyards,

researchers, manufacturers of TBT, industries that incorporate TBT into their products, state and federal regulatory agencies, and Regional Water Control Boards, to gain information concerning TBT disposal in waste streams.

The purpose of this study was to identify practical technologies that could be used by shipyards to remove TBT from large volumes of water to levels below 50 ng/L. This study was based on: (1) a review of scientific and engineering literature, (2) a review of U.S. Patents, and (3) a survey of manufacturers and industrial users. The study concluded:

- **There is no "off-the-shelf" technology directly applicable to shipyard waste streams that will reduce TBT levels in water below a concentration of 50 parts per trillion.**
- **Because TBT is highly attracted to particles in water, adsorption process may prove be the most effective means to reduce TBT concentration. It is suggested that technology such as Dissolved Air Floatation, and Activated Carbon Adsorption are the best candidate technologies.**

Also in 1997, in the absence of any available technology, Norfolk Shipbuilding and Drydock Corporation (NORSHIPCO), a member of the CASRM consortium, decided to determine how much progress could be made toward meeting the <50 ng/L goal using different types of standard (off the shelf) water treatment equipment. Subsequently, NORSHIPCO assembled a small industrial water treatment processing plant to conduct some preliminary studies to treat the washdown wastewater using equipment leased on a trial basis. The equipment was not properly sized for the water flow, nor was it used in an optimum way. The results were, however, sufficiently

encouraging that water treatment was repeated on a series of subsequent TBT jobs, using variations of equipment to try different alternatives.

SUMMARY OF TREATMENT STUDIES AT NORSHIPCO, 1997 AND 1998

These studies were conducted on a large floating dry-dock having a smooth cambered deck on which heavy machinery could be easily relocated. With this kind of dry-dock, ballast tanks are flooded to sink the dock, the ship to be repaired is floated into the dock, and air is pumped into the tanks to raise the dock and the ship out of water. The average size of vessels included in this study was approximately 800' long and 100' wide, and having an underwater hull area in excess of 100,000 square feet.

Washdown is the first operation to be initiated as soon as the ship is out of the water. Typically this is done manually, using a crew of about 20 laborers, and continues through several shifts for a total of about 30 hours. Each operator uses a moderate pressure water washer, using fresh water only at a rate of 4 gpm. Typical water usage on this job is 140,000 gallons. The washdown serves to remove three materials from the hull: sea salt, a wet marine slime, which has the texture and appearance of dead algae, and the top layer of antifouling paint.

After washdown, the hulls of all the ships in this study were inspected, and in every case were found to be in excellent shape with little or no damage from corrosion or marine growth. This is testimony to the efficacy of modern TBT antifouling paints. Washwater was collected by ballasting the dock in order to tilt it slightly, so that all the washwater drains to one end, where it was collected in troughs on the apron of the deck. From here the water was pumped to holding tanks to await treatment.

Figure 1 provides a flow diagram for the experimental treatment system that has been developed following the NORSHIPCO experimental water treatment studies in 97 and 98. The equipment used in the NORSHIPCO studies included: (1) Dissolved Air Flootation to remove suspended solids, (2) a sand filter to remove fine suspended solids and (3) an activated carbon bed to remove dissolved organic materials including TBT. These technologies have been included in the design of the CASRM Barge Treatment System and Process Train, see Figure 1 below.

Water samples were sent to a commercial laboratory for analysis of TBT concentration and toxicity. TBT concentrations in different water samples collected from different treatment steps over time as ship washdown wastewaters were being treated is presented in Table 1 on the next page.

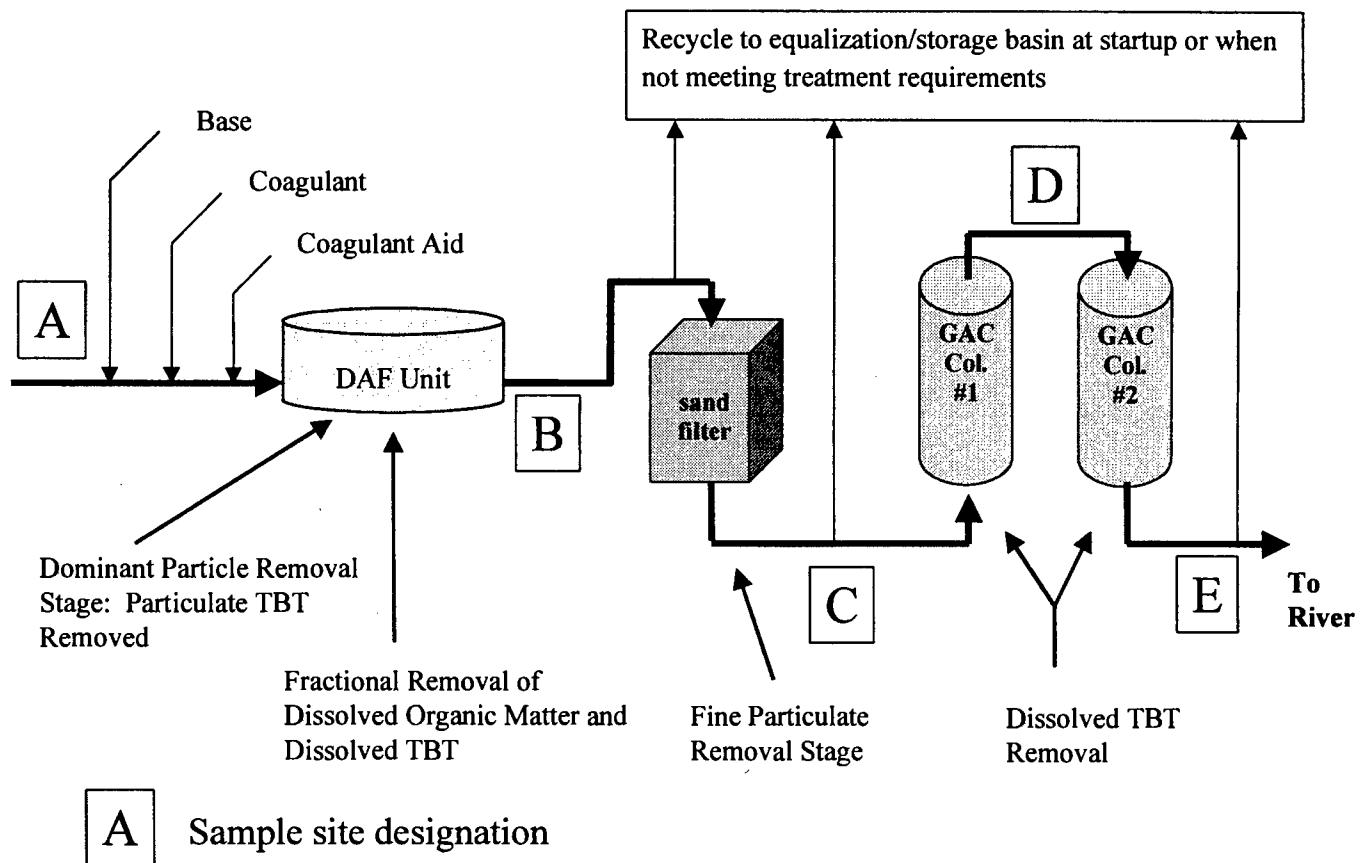

Figure 1. Schematic of the 1999 CASRM Barge Treatment Plant SYSTEM and Process Train for TBT Removal.

Table 1. Test results to remove TBT from shipyard wash water during 1997.
Data courtesy of NORSHIPCO, Norfolk, VA.

<i>Ship</i>	<i>Equipment Sequence</i>	<i>Treatment Stage</i>	<i>TBT Levels (ng/L)</i>
<i>Fascination</i> <i>4/29-30/97</i>	<i>DAF; Carbon(1)</i>	<i>Pre Carbon</i>	<i>180,000</i>
		<i>Post Carbon</i>	<i>310</i>
		<i>Post Carbon</i>	<i>210</i>
		<i>Post Carbon</i>	<i>2,140</i>
<i>MV Po Hang Yu</i> <i>7/2/97</i>	<i>DAF; Sand; Carbon (1)</i>	<i>Trough</i>	<i>8,300</i>
		<i>Pre DAF</i>	<i>11,000</i>
		<i>Pre Carbon</i>	<i>8,500</i>
		<i>Post Carbon</i>	<i>70</i>
		<i>Post Carbon</i>	<i>69</i>
<i>Zealand Expedition</i> <i>8/2/97</i>	<i>DAF; Sand; Carbon (1)</i>	<i>Pre DAF</i>	<i>8,100</i>
		<i>Pre Carbon</i>	<i>8,000</i>
		<i>Post Carbon</i>	<i>790</i>
<i>Inspiration</i> <i>9/12/97</i>	<i>DAF; Sand; see text</i>	<i>Pre DAF</i>	<i>485,000</i>
		<i>Post Carbon</i>	<i>18,000</i>
		<i>Post Carbon</i>	<i>41</i>
		<i>Post Carbon</i>	<i>210</i>
<i>Ecstasy</i> <i>1/30/98</i>	<i>DAF; Sand; Carbon (1)</i>	<i>Post Carbon</i>	<i>540</i>

The first set of data for the cruise ship *Fascination* found that the TBT concentration prior to passing through the carbon bed was 190,000 ng/L. TBT levels in wash water from all ships prior to passing through carbon absorbent varied from 8,300 ng/L to 480,000 ng/L. This may reflect different levels of TBT in different types of paint.

Activated carbon is very effective in removing dissolved TBT from water. The data from the *Inspiration* is particularly striking. The concentration of TBT in the water stream was reduced from 480,000 ng/L to 41 ng/L by passing it through the carbon bed. This level would meet

the Virginia discharge limit goal of 50 ng/L. The key to effective TBT removal by carbon is effective removal of suspended solids by earlier stages, and providing for sufficient volume of carbon to handle the adsorption load.

It should be recognized that carbon would adsorb nearly all organic material presented to it, so it is important to reduce the presence of other organic contaminants in wastewaters as much as possible. Adsorption is a surface area phenomenon. As carbon adsorbs organic material, there is less surface area left and its adsorption efficiency drops as it becomes exhausted. Previous work by

CASRM on storm water runoff from a dry-docks suggests that non-TBT dissolved organic material may be several orders of magnitude higher than TBT concentration.

Over the five ship series, the TBT removal rate varied from 90% to 99.99%. On one occasion, the goal of <50 ng/L was achieved, but 12 hours later performance had dropped to 210 ng/L.

These tests at NORSHIPCO demonstrated the potential of a carbon based system to be able to remove TBT from wastewaters to below 50 ng/L, and focused attention on areas where further R&D was needed. A major concern was to refine and make the process more efficient and cost effective and to reduce the amount of carbon utilized and total waste residue.

The equipment utilized in the NORSHIPCO studies was not optimum; they were chosen because they were available off the shelf at the time. The DAF was rated at 25 GPM, but in order to keep up with shipyard production schedule, it was operated at rates up to 60 GPM. In addition the DAF was optimized for removal of metals (zinc

and copper), not removal of TBT. The carbon bed was also severely undersized for the water throughput used.

Another difficulty experienced during these studies was the time delay between submitting water samples and receiving TBT analysis results. The commercial laboratory chosen routinely required three weeks to report TBT numbers. In many cases, the ship had left dry-dock before TBT levels in the water samples were known. Enquiries with various laboratories revealed that TBT analysis at levels of parts per trillion is very complicated, labor intensive, and expensive at these levels. In a laboratory set up to perform TBT analysis routinely, a minimum of two days is required per sample.

It became clear during these tests that a much faster (shorter time period) method for analyzing the water effluent was required. During the shipyard tests, the equipment was set up and operated during the wash-down without any real time knowledge of the TBT level in the effluent. A rapid method to assess TBT concentration is needed for treatment system process control.

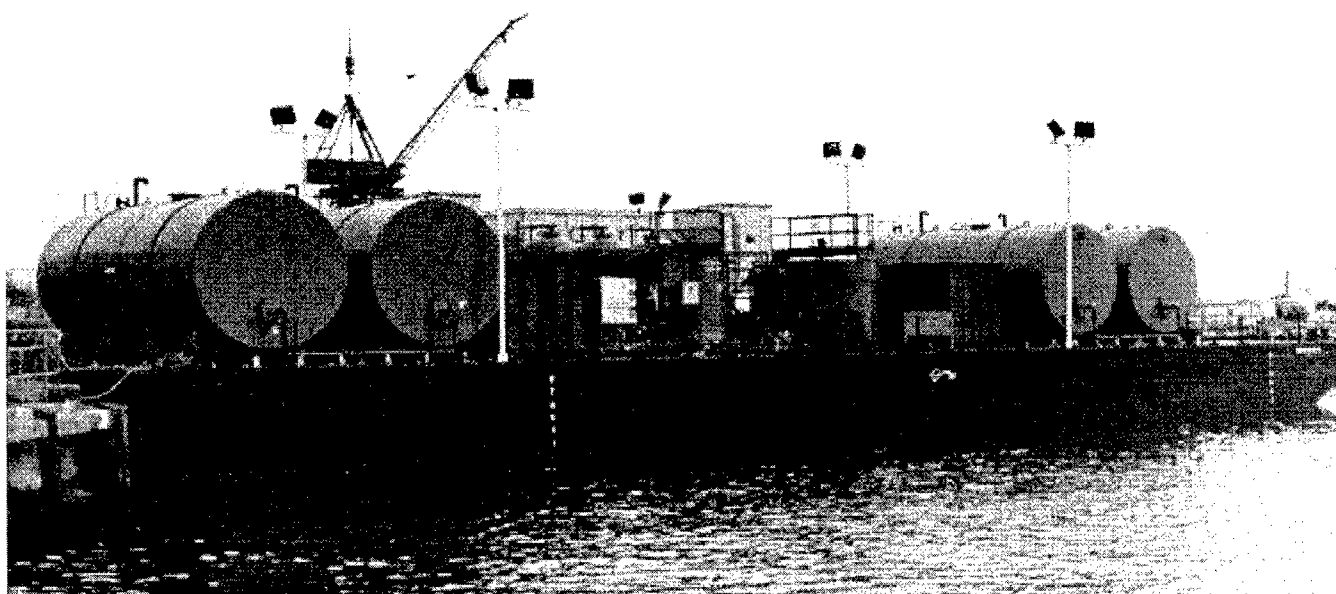

Figure 2. The CASRM Barge Treatment Plant SYSTEM and Process Train for TBT Removal.

CURRENT R&D

For the past year, the CASRM Consortium has been engaged in an intensive effort toward achieving shipyard compliance. Cooperative research and demonstration contracts from US EPA and the Virginia Department of Environmental Quality have enabled the CASRM Consortium to implement the following four-phase research and development implementation plan:

Phase 1. A full scale, fully engineered version of the 97/98 NORSHIPCO experimental system has been constructed, and deployed on a floating barge (November – December, 1999). The system, designed to treat 100 GPM, has a recycle type DAF system, a mixed media filter and two high-pressure carbon canisters. The carbon bed is sized to achieve a water-carbon contact time of over twenty-five minutes at full flow. The system is fully instrumented; operating variables are monitored and logged in real time by computer. There is provision to add other water treatment processes in the future. A photograph of the CASRM barge and water treatment system is presented in Figure 2. The System being barge mounted allows the treatment system to be moved conveniently to any dry-dock in the region where TBT washdown wastewater is being generated. The barge is completely self contained. It can be towed into place before the ship is dry docked, and can collect and process (treat) wastewater as soon as cleaning begins.

Phase 2. Laboratory analysis and bench scale tests will be used to optimize the barge based pilot plant treatment system and process and to evaluate alternative treatment processes, which may be utilized. Alternative processes include the use of oxidizers such as hydrogen peroxide and ozone, and the use of ultraviolet light to degrade TBT in wastewaters.

Phase 3. A FAST TBT Method for analysis of TBT in washdown and treated wastewaters is being

developed. The current industry standard method of measuring TBT in water at concentrations measured in parts per trillion (ng/L) is complicated, labor intensive and requires a minimum of two days per sample to complete. A Fast Method for TBT analysis is required to monitor the performance of any treatment process developed to remove TBT. The goal is to be able to measure levels as low as 30 ng/l in less than ten minutes, which is the required QL level in the Consent Agreement.

Phase 4. The results of phase one, two and three will be combined and incorporated into development of a pilot plant water treatment system. This system will be tested under real industry production situations (100,000 gallon levels in 30 hours).

It is expected that this project will result in the development of a self-contained TBT treatment System to reliably achieve less than 50 ng/L TBT effluent. Design and operating data will be used to develop a design guide for modular TBT removal systems suitable for different conditions. The results will be disseminated to industry, the scientific community and the public. A Quality Assurance Project Plan (QAPP) has been prepared (Champ et al., 1999) to obtain the highest level of QA/QC for the entire project and full verification and validation of the FAST TBT Method.

ACKNOWLEDGEMENTS

This CASRM Project is funded through a partnership by industry, academia and government (Federal and State) as a cooperative research, development and demonstration project funded by the Office of Water (U.S. Environmental Protection Agency), the Department of Environmental Quality (Commonwealth of Virginia), and a Consortium of the Norfolk area shipyards with construction and operation support from Newport News Shipbuilding and NORSHIPCO.

REFERENCES CITED

- Alden III, R.W., R.J. McDanie II, T.A. Ribeiro, L.M. Ramirez, J.H. Rose. 1996. A Literature Search for the Effects of Tributyltin on Aquatic Organisms and Current Tributyltin on Aquatic Organism and current Tributyltin Regulatory Limits Among Regulatory States of the United States. TR. No. 3008. Applied Marine Research Laboratory. Old Dominion University, Norfolk, VA 23529-0456. 157p.
- Argamen, Y., Hucks, C.E. and S.E. Shelby. 1984. The Effects of Organotin on the Activated Sludge Process. *Water Research*. **18**(5): 535-542.
- Champ, M.A. and P.F. Seligman. (Eds). 1996. *Organotin, Environmental Fate and Effects*. Chapman and Hall. London. 674p.
- Champ, M.A., G.C. Schafran, T.J. Fox, G.A. Cutter, M. Unger, and G. Salata. 1999. Quality Assurance Project Plan for the Analysis and Treatment of TBT in Waste Waters from Virginia Shipyards and Drydocks. CASRM. Norfolk, Virginia. 170p.
- de Mora, S.J., C. Stewart and D. Phillips. 1995. Sources and Rate of Degradation of Tributyltin in Marine Sediments Near Auckland, New Zealand. *Marine Pollution Bulletin*, **30**(1):50-57.
- Fent, K. 1996. Organotin Compounds in Municipal Wastewater and Sewerage Sludge: Contamination, Fate in Treatment Process and Ecotoxicological Consequences. *The Science of the Total Environment*. **185**:151-159.
- Grovhoug, J.G., P.F. Seligman, G. Vafa, and R.L. Fransham. 1986. Baseline Measurements of Butyltin in U.S. Harbors and Estuaries. *Oceans '86, Vol 4, Organotin Symposium*, Washington D.C. Vol. 4:1283-1288
- Messing, A.W., L.M. Ramirez and T.J. Fox. (1998). A Review to Determine State-of-the-Practice Treatment Technologies for Reducing Concentrations of Organotin Compounds in Wastewater. *National Shipbuilding Research Program Report*. Ann Arbor Michigan. 57p.
- Page, D.S., C.C. Ozbal and M.E. Lamphear. 1996. Concentration of Butyltin Species in Sediments Associated with Shipyard Activities. *Environmental Pollution*. **81**(2):237-243.
- Seligman, P.F. (1984) "Fate and Effects of Organotin Antifouling Leachates in the Marine Environment." Bethesda, MD.

Process Water Treatment for the Removal of TBT in Ship Washdown Waste Waters

Peter L. Ashcroft¹ and David Abel².

ABSTRACT

A consortium is being created to commercialize a cost and environmentally beneficial water treatment process for the removal of TBT from ship washdown wastewaters developed in the UK at the University of Sunderland. The solvent extraction process, initially developed through funding from EC MEDSPA project, is to be exploited by a new group set up to introduce the technology to a wide range of industrial processes. A key target, for which the system was developed is treatment of TBT contaminated dockyard process effluent. The technology has been proven in one pass to reduce TBT levels from 2mg.l⁻¹ to 200ng.l⁻¹. The estimated cost for each metric tonne of effluent treated is £4 (<\$7).

KEYWORDS: Tributyl-tin, wastewaters, ship washdown wastewaters, treatment, drydocks, shipyards.

INTRODUCTION

The development, testing and commercialization of this technology has been over a ten year period:

- 1991 University of Sunderland proposal
- 1992 EC MEDSPA support
- 1995 Pilot scale process demonstrated
- 1996 Joint-venture formed for scale-up
- 1997 10te.hr⁻¹ system proved

The extraction process is carried out by dispersion of an appropriate solvent in the process water stream. The dispersion provides an environment for mass transfer of the target species into the extraction phase (solvent). To achieve this end the solvent is dispersed to form a high surface area to enable mass transfer to take place. Once the extraction process is complete the solvent dispersion is coalesced for post-extraction treatment of the waste stream.

The development includes a patented process for development and maintenance of a large surface area at which interface the mass transfer takes place. The final part of the process involves the coalescence of the dispersed phase for separation and recovery / disposal of the target pollutant.

The new consortium expects to have a laboratory / pilot installation available early in 2000. This will be used to further evaluate performance and design the commercial units to be made available later in 2000.

OBJECTIVES & PROCESS OPERATION

The consortium objectives are to promote and exploit the technology because of what are seen as substantial process benefits. These are clearly apparent when the process is compared to alternative technologies applied to TBT and similar water treatment problems.

The benefits of this technology include:

- a) minimization of waste volume;
- b) no generation of solid waste;
- c) avoidance of civil works;
- d) design as a mobile, modular system;
- e) parallel operation with waste production;
- f) elimination of need for process water storage;
- g) minimization of operating costs;
- h) adaptability for future changes in standards;
- i) applicability to other pollutant streams; and
- j) robust construction for industrial operation.

A major benefit is a massive volume reduction in terms of the waste stream from the process. The operating parameters require a solvent volume amounting to between 2 and 4% of the process mass. If a nominal $10\text{te}\cdot\text{hr}^{-1}$ is processed during a

10-hour period 100te of process water will be treated. The hold up volume of the system pipe work will be some hundreds of liters. This gives an average requirement substantially below 100 liters of extraction fluid. The external hold up volume where post processing of the extraction fluid may take place could lead to a parallel solvent reservoir of perhaps 200 liters to allow for any secondary processing. This will not necessarily change even if the unit is operated continuously for days or weeks.

In practice it has been identified that a wide range of oils are suitable as extraction solvent. It may be acceptable locally to use an existing waste oil stream to effectively avoid creation of an additional waste stream.

The process is viewed as a series of separate modules. The individual components are illustrated in the schematic presented below in Figure 1.

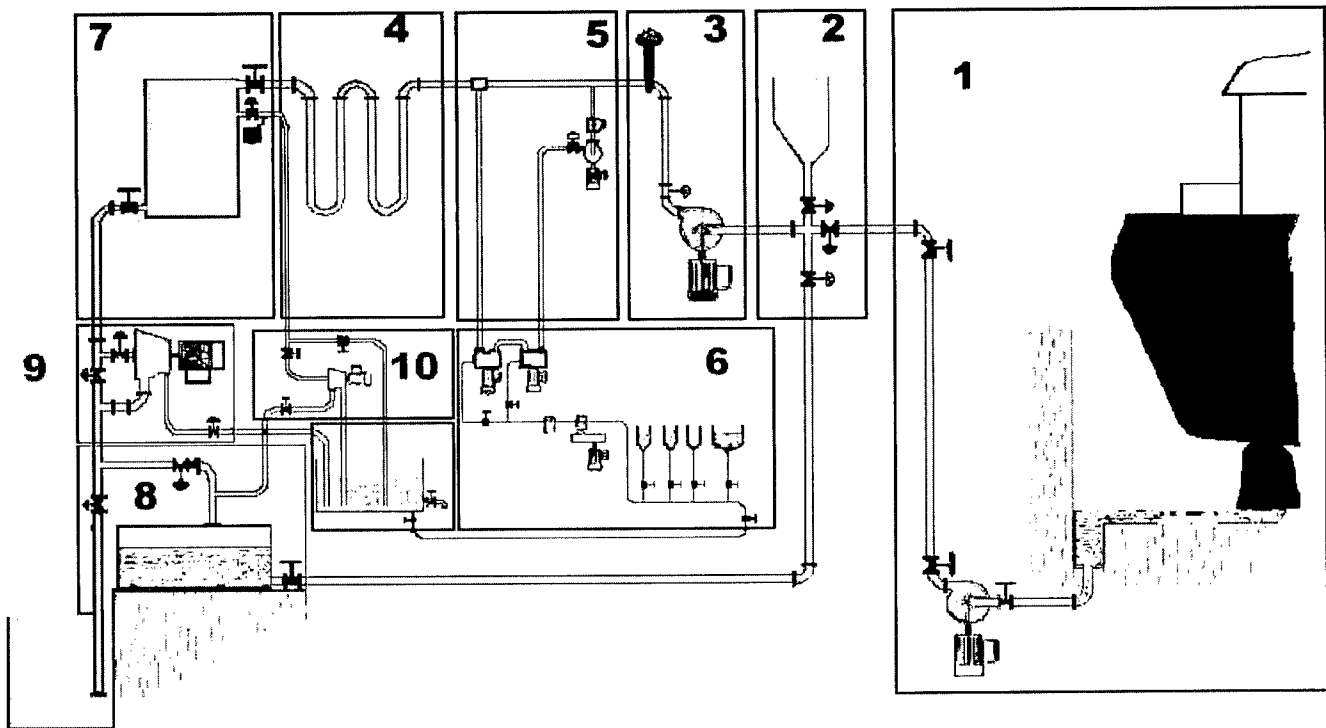

Figure 1. A schematic illustrating the components of the technology. See following text for legend.

The first module [1] includes a transfer pump to take the process stream from the source and will include primary screening to remove solids etc. The front end of the process unit will have a reservoir [2] to allow priming of the system prior to initiating treatment. This primary fluid stream will then be pumped [3] to the "reactor pipe work" [4]. A controlled fraction of the main flow is diverted [5] to the dosing system [6]. In this module, a concentrate is made with the extraction solvent being dispersed in the process liquid. The system will be capable of admitting any extraction solvent appropriate to the target pollutant.

The "reaction" module [4] maintains the dispersion of extraction solvent while the pollutant is extracted. The treated mixture then enters the separation module [7] where the solvent and cleaned water streams are separated. The water can go for discharge [8] or "polishing" [9] according to local quality standards. The oil stream is collected [10] for reuse, treatment or disposal according to local requirements. The solvent collection module can include secondary processing, recycling or simple discharge facilities.

PROTOTYPE PERFORMANCE

The technology has been proven to operate in an industrial environment with the ability to reduce TBT levels from 2mg.l^{-1} to 200ng.l^{-1} . The use of repeat extraction modules will give progressive further reduction with no effective increase in waste volume produced. The estimated cost for each metric tonne of effluent treated is £4 (<\$7).

REFERENCES CITED

EC MEDSPA. 1991. Contract No. 91-1/UK 002/INT/06. GB Patent (Pending) 97 01894.

¹Kestrel Services 2000 Ltd., Wallsend Research Station, Davy Bank, Wallsend, NE28 6UZ, UK. Tel. +44 (0)191 234 0800, Fax +44 (0)191 234 1331, Mobile: +44 (0)777 1661 809, E-Mail: information@kestrel2000.co.uk

²Ecology Centre, University of Sunderland, Sunderland, SR1 3SD, U.K, Tel: +44 191515-2533, Fax +44 191 515-2534, E-Mail: david.abel@sunderland.ac.uk

Minimization and Treatment of Shipyard Wastewater

Bhaskar Kura¹ and Raghuram Tadimalla²

ABSTRACT

Shipyard operations generate significant quantities of wastewater apart from stormwater and sanitary wastewater. Efficient management of the wastewater streams results in reduction of costs, reduced liability, improved public image and environmental compliance. The pollution prevention options discussed in the paper follow the principle of source reduction which is the best alternative among all P2 options. The control techniques have been given for cleaning and degreasing operations, organic coating removal, surface treatment and plating operations. Use of aqueous cleaning solutions, process changes, efficient rinse systems, alternative process baths, numerous blasting techniques can be utilized for reducing the strength of the pollutants in the wastewater streams. Treatment would be required before final disposal into the waterbody to make water safe to aquatic life. Biological and physico-chemical treatment options are available to treat shipyard process wastewaters and bring the pollutants below the discharge standards.

INTRODUCTION

The shipbuilding and ship repair industry generates significant quantities of wastewater from various operations. Some of the major operations that generate wastewater are vessel cleaning operations, water used for cleaning the equipment, and water used in the processes (Kura, 1996a, 1996b). Apart from the washwaters, sanitary wastewater is generated at various restrooms and portable bathrooms within shipyards. A typical shipyard with dry-dock capability can generate as high as 7 million gallons of wastewater in addition to sanitary wastewater and stormwater. Such an enormous quantity calls for efficient management of shipyard wastewaters. Management techniques such as source reduction, waste minimization, control, treatment etc. can be effectively utilized in the

reduction of waste strength. This paper is the compilation of the available literature that relates shipyard wastewater minimization and treatment options.

WASTE MINIMIZATION

Waste minimization options are adopted more for process waters than for stormwater or sanitary wastewater because the reduction in toxicity, strength, and others is required in case of process waters. Control technologies can be adopted to minimize the strength of the waste streams coming out of various processes. These technologies or methods have been given in the following sections. Most of these methods follow the concept of source reduction which is the best alternative for pollution prevention.

Control Techniques for Cleaning & Degreasing Operations

In all of the control techniques that involve replacement of raw materials, care has to be taken to see that the quality of the replacement material satisfies the job requirements. In case of cleaning and degreasing operations, the solvent should have excellent solvency for a broad range of organic materials particularly oils and greases (EPA, 1994a). The solvent should preferably be non-flammable, non-corrosive, low toxicity, low heat of vaporization i.e., a high vapor pressure that allows evaporative drying of cleaned parts, and chemical stability. The chlorinated degreasing solvents have been extensively used in shipbuilding industry as they satisfy all the properties. The key chemicals of importance are methylene chloride (DCM), perchloroethylene (PCE) trichloroethylene (TCE) and 1,1,1-trichloroethane (TCA). The chlorinated solvents are also highly mobile in soil and ground water and are common ground water contaminants.

There are two viable options that can be adopted for minimizing the waste in cleaning and degreasing operations: alternative cleaning solutions and process changes.

¹Associate Director of Maritime Environmental Resources and Information Center (MERIC), Associate Professor of Civil & Environmental Engineering, University of New Orleans, University of New Orleans

²Research Assistant, Department of Civil & Environmental Engineering, University of New Orleans

Alternative Cleaning Solutions

Cleaning and degreasing can be broadly grouped as chemical, electrochemical, or mechanical in nature. The chemical properties possessed by a cleaner or solvent determine whether the cleaner or solvent acts by displacing, dissolving, or in some way chemically altering the contaminant on a substrate and hence causing its removal. Described below are chemical alternatives to chlorinated solvents that can be used to reduce waste in cleaning and degreasing operations.

Aqueous Wash Systems

Aqueous cleaning systems, or parts washing systems have been used for years to remove salts, rust, scale, and other inorganic soils from ferrous metals. Aqueous cleaning systems can include alkaline solutions and detergents to enhance their soil removal capabilities or consist of solely hot water washes. These systems are often used with pressurized sprays, agitation, ultrasonics, filtration, heat, or some other physical process to further provide effective cleaning.

Aqueous cleaners are mixtures of water, detergents, and other additives that promote the removal of organic contaminants. Some additives of aqueous cleaning systems include synthetic detergents and organic surfactants, saponifiers, acids and alkalies, and corrosion inhibitors. The combination of additives selected alter the foaming, wetting and soil removal properties of the solution. Detergents and surfactants are the surface-active agents that emulsify insoluble solids into solution. Saponifiers change water insoluble fats and fatty acids into water soluble soaps. Oxidants may be added to loosen rust and stains for easy removal. Depending on the requirements of subsequent operations, rinsing may be required to remove residual films left by these additives in the cleaning process.

Semi-aqueous Cleaning Systems

Semi-Aqueous cleaners comprise a group of cleaning solutions that are composed of natural or synthetic organic solvents, surfactants, corrosion inhibitors, and other additives. Semi-aqueous cleaners are designed to be used in process equipment much like that used with aqueous cleaners. The commonly used semi-aqueous cleaners include water-immiscible types (terpenes, high-molecular-weight esters, petroleum hydrocarbons and glycol ethers) and water miscible types (ketones, esters, and organic amines). One water miscible solvent, N-methyl-2-pyrrolidone (NMP), commonly used for large scale cleaning and paint removing which can be most suitable for shipyards.

Petroleum Hydrocarbons

Petroleum hydrocarbons are available in two grades, the basic petroleum distillates the older ones which were available many years before chlorinated solvents attained popularity. The other one is the speciality grade of synthetic paraffinic hydrocarbons, the most recent technologies which have high solvencies for many hard to clean organic soils, including heavy oil and grease, tar, and waxes. In addition they have low surface tensions which allow them to penetrate and clean small spaces. Petroleum hydrocarbon cleaners are compatible with most metals and plastics and with some elastomers.

Process Changes

The process changes result in reduction of contaminants in the process wastewaters. Some of the viable process changes are

- Automated aqueous cleaning
- Aqueous power washing
- Ultrasonic cleaning

Automated Aqueous Cleaning

Automated aqueous cleaners use aqueous cleaning solutions instead of solvents to achieve high quality cleaning. These automated machines also have features for significantly reducing the amount of wastewater generated. These machines remove some of the contamination that comes out from the parts being cleaned into the cleaning solution. The cleaning solution can then be recirculated for cleaning several times.

Aqueous Power Washing

The Aqueous power washing is similar to the automated aqueous washer in that it combines innovative process technology with the use of an aqueous cleaning solution. Unlike the automated washer which has a

continuous operation, most power washers are batch units. The power washer is most suitable for larger parts and is done by blasting from all sides with water or cleaning solutions in an enclosed chamber.

Ultrasonic Cleaning

Ultrasonic cleaning makes use of cavitation in an aqueous solution for greater cleaning effectiveness. In ultrasonic cleaning, high frequency sound waves are applied to the liquid cleaning solution. These sound waves generate zones

of high and low pressures throughout the liquid. These pressures and temperatures loosen contaminants and perform the actual scrubbing of the ultrasonic cleaning process.

The oily and greasy residue can also be removed by steam cleaning process. Heat accelerates emulsification, breakdown, and removal of caked-on dirt and grease. High temperature is maintained on the surface long enough for the steam to vaporize or liquefy the oil, grease, or dirt. This process reduces the amount of hazardous waste and hazardous air emissions generated in solvent degreasing. The wastewater stream generated can be easily treated at the treatment plant eliminating complications due to presence of toxics. Another method is the mechanical cleaning process to reduce waste production and eliminate potential safety problems with the handling and usage of toxic, ozone depleting, and often flammable solvents. Brushing, grinding, polishing, and sanding are some of the mechanical cleaning procedures adopted for this purpose. The mechanical cleaning process significantly reduces the amount of wastewaters/hazardous waste generated compared to chemical stripping and also reduces the treatment and disposal costs.

Control Techniques for Organic Coating Removal

Solvent strippers have been widely used for industrial coating removal for many years. The solvent strippers can remove a range of organic coatings at room temperatures without attacking metal substrates. Acidic solvent stripper typically include phenol, formic acid, and methanol mono-ethanol amine in the formulation in addition to the methylene chloride present in the ordinary solvent strippers. Methylene chloride removes the coating mainly by causing it to swell and then lift off the substrate. Because of the small size of the methylene chloride molecules, they penetrate beneath the coating surface to the substrate and cause the film to swell and lift off the substrate. The coating presents a bubbling and blistering surface, which signifies that the surface is ready for scraping or flushing.

Cleaner technologies are based on the physical removal of coatings to replace the use of solvent strippers. The difference in physical properties between coating and substrate is used for removal of coating. There are three general physical principles that can be adopted to replace solvent strippers (EPA, 1994c) and are

- Abrasive blasting technology
- Cryogenic technology
- Thermal technology

The nine available cleaner technologies based on these physical methods are plastic media blasting, wheat starch blasting, burn off coating removal, molten salt coating removal, sodium bicarbonate wet blasting, carbon dioxide cryogenic blasting, high-pressure water blasting, medium-pressure water blasting, and liquid nitrogen cryogenic blasting.

There has been increasing focus on tributyl tin as it is highly toxic. The standards exist only in the state of Virginia. Appropriate treatment technology has not been identified yet for wastewater containing tributyl tin. However, some BMPs (Best Management Practices) like cleaning of the dry dock and marine railway carriages before launching operations to eliminate the contamination of the waterways by tributyl tin compounds, ensuring proper enclosure of open blasting operations near the waterways to contain the spent abrasive media and the paint chips etc., are being followed to minimize the contamination of the wastewater stream by tributyl tin.

Control Techniques for Surface Treatment and Plating Operations

A wide variety of materials, processes, and products are used to clean, etch, and plate metallic and nonmetallic surfaces. Typical metal finishing processes include plating, anodizing, stripping, etching, degreasing, cleaning, tooling, buffing, grinding, polishing and other finishing steps. Some examples of the plating baths are nickel, tin, zinc, copper, cadmium, and gold baths. The process steps that generate wastes include plating, anodizing, etching, stripping, and rinsing steps. Wastes include spent baths, cleaning baths, and contaminated rinse water. The control techniques for surface treatment and plating operations can be categorized into two groups: process bath changes and rinse systems.

Process Baths

Source/waste reduction at the process-bath level can be established by material substitution, bath life extension, and/or drag-out reduction. Material substitution options include modifying the chemistry of the process baths or replacing the chemicals used for a given process. Because process bath chemistries vary widely from plant to plant, these options are described below only in general terms.

Deionized water can be used to replace tap water for process bath makeup and rinsing operations. Natural contaminants found in tap water (e.g., carbonates, phosphates, etc.) can reduce the rinse water efficiency, minimize the potential for drag-out recovery, and increase the frequency of changing the process bath.

Converting to non-cyanide baths can simplify wastewater treatment, saving the cost of treatment chemicals and reducing sludge generation. Replacement chemistries are available for most cyanide containing process baths, with the exception of copper strike baths used for copper plating. This is an electrolytic process and is similar to cyanide based plating. Alkaline non-cyanide processes operate in pH of 8.8 to 9.8 compared to the pH of 13 to 14 for the cyanide process. Alkaline non-cyanide copper plating solutions eliminate cyanide from rinse water and sludge generated during waste treatment of the rinse water. Non-cyanide baths contain one-half to one-quarter as much copper as full strength cyanide processes, resulting in lower sludge volume generation rates. The sludge from waste treatment of cyanide bearing rinse water can be particularly difficult to dispose of because of residual cyanide content, which is regulated by RCRA to a maximum of 590 mg/kg of total cyanide and 30 mg/kg of cyanide amenable to chlorination. By eliminating cyanide from rinse water, compliance with cyanide regulations in wastewater discharges is ensured. Rinse water from alkaline non-cyanide copper plating only requires adjustment to precipitate copper as the hydroxide. This eliminates the need for a two-stage chlorination system from the waste treatment system and avoids the use of chemicals such as chlorine and sodium hypochlorite.

Rinse Systems

The greatest amount of wastes generated by the metal finishing operations comes from the treatment of wastewater resulting from rinsing operations required after the plating, stripping, and cleaning processes. The use of most wastewater treatment chemicals depends on the volume of wastewater generated. Therefore, it is important that rinse water usage be reduced in order to minimize waste generation in the metal finishing industry. Rinse water usage may be reduced by improving the rinsing efficiency and/or by controlling the water flow rate.

Rinsing efficiency may be improved by providing enough turbulence between the workpiece and the rinse water, sufficient contact time between the workpiece and the rinse water, and a sufficient volume of water during contact time. However, the last strategy causes the use of significantly more rinse water than required.

To improve the turbulence between the workpiece and the rinse water, spray rinsing or rinse water agitation systems may be used. Spray rinsing uses between 15 and 25 % of the volume of the water that a dip rinse system uses. However, it is not applicable to all metal finishers because the spray rinse may not reach all parts of certain work pieces. Spray rinse systems may be used along with dip rinse systems

(immersion rinse systems) as a first rinse step after the work pieces are removed from the process tank. This removes most of the drag-out before the workpiece is submerged in the dip rinse tank. Spray rinses can also be installed above the heated process tanks with rinse water volume less than or equal to the water loss resulting from evaporation. This allows the drag-out and rinse water to drain directly to the process bath, thus replenishing the bath solution.

Agitation between the workpiece and the rinse water can be achieved by using forced air or forced water systems. In these systems, air or water is pumped into the immersion rinse water tank. Air agitation is thought to provide the best type of turbulence for removing process bath chemicals. An air sparger at the bottom of the rinse water tank is frequently used for forced air systems.

The use of multiple-stage rinse tanks can increase contact time between the workpiece and the rinse water, thus improving the rinse efficiency. A countercurrent multiple-stage rinse tank system can also reduce the amount of water usage (by 90 % when compared with a conventional single-stage rinse system). In a multistage countercurrent rinse system, the rinse water flow moves in an opposite direction to the workpiece flow. The disadvantages of multistage countercurrent rinse systems are that more process steps, additional equipment, and greater work space are required.

Rinse water usage can also be reduced by controlling the flow rate. Flow restrictors can be used to limit the volume of the rinse water and maintain a constant flow of fresh water into the system. A conductivity or pH meter can also be used to control the flow of fresh water into the rinse system by monitoring the level of dissolved solids or pH in the rinse water. When the concentration or pH reaches the preset maximum level, the probe can activate a valve which opens to allow an additional flow of fresh water into the rinse water system.

There also exist the recycling and resource recovery technologies to the metal finishing operations. To reuse or recovery a waste stream for another process and to recycle rinse water, the waste stream must be separated from other wastes that may interfere with the reuse or recovery process. Therefore, implementation of recycling and resource recovery techniques will generally require process piping modifications and additional storage tanks to provide the necessary segregation of materials.

After the rinse water becomes too contaminated for the original process, it may be useful for other rinsing operations in which the purity of the water is not crucial to the process. For example, the effluent from a rinse tank following an

acid cleaning bath can be reused as influent water to a rinse tank following a basic cleaning bath. Not only is water usage reduced by 50 % (assuming both rinse tanks require the same water flow rates), but at the same time rinsing efficiency is improved, owing to the neutralization reaction that reduces the concentration of alkaline chemicals. Neutralization reactions can also reduce the viscosity of the alkaline drag-out film.

Acid cleaning rinse water effluent can be used as rinse water for work-pieces that have gone through a mild acid etch process. Rinse water from a final rinse, which is less contaminated than other rinse waters, can be used as influent for other rinsing operations that do not require high rinse efficiencies.

Alkaline or acidic spent process chemical baths can be used to adjust pH during waste treatment. However, they should not be used for final pH adjustment since they often contain high concentrations of metals.

Because of the increased regulatory requirements on handling and disposal of wastes containing metals, and the subsequent increase in treatment costs, it has become more economical to recover metals and metal salts from process baths. Metal recovery may be used in two ways:

- Recovered elemental metals can be sold to a metal reclaimer
- Recovered metal salts can be recycled back to the process baths

The available techniques for recovering metals and metal salts are evaporation, reverse osmosis, ion exchange, electrolysis, and electro dialysis (closed loop [Fig. 1] and open loop [Fig.2] systems).

TREATMENT

The treatment of the wastewater is generally carried out on-site owing to substantial quantities of wastewater generated in the shipyard. A typical shipyard may generate up to seven million gallons of wastewater from process/washwater streams. This figure does not include stormwater and sanitary wastewater. Treatment of wastewater involves preliminary treatment, primary treatment followed by secondary treatment. The secondary treatment can be chosen from two alternatives: biological treatment and physico-chemical treatment. These treatment options have been discussed in the following sections.

Biological Treatment

Suspended solids in a shipyard wastewater can be of two types: settleable and non settleable. The former can include grit and other discrete particles that can be easily removed in a grit chamber. Settleable organic particles can be removed in a primary sedimentation tank (La Motta and Kura, 1997). The non settleable particles can be colloidal and dissolved particles, both organic and inorganic. The organic biodegradable fraction can be removed using conventional biological treatment processes, while the inorganic colloidal solids need some form of flocculation to become settleable.

Based on the wastewater characteristics of a typical shipyard, the following treatment processes are deemed necessary to obtain concentrations below discharge limits: preliminary treatment, primary treatment, secondary biological process, secondary settling, effluent filtration, adsorption of non biodegradable organics, final effluent disinfection and sludge treatment.

Preliminary Treatment

The first unit process in a shipyard wastewater treatment plant would be the grit chamber, preferably aerated. In shipyards grit would be composed of sand, metal chips, or other heavy discrete particles generated in metal surface preparation. Grit must be removed because its inclusion within the system can abrade mechanical equipment and settle out in pipelines, channels and conduits, and interfere with biological treatment of sludges.

Two common types of grit collection devices are (Kiely, 1997) the helical flow aerated grit chamber and the horizontal flow grit chamber.

Primary Treatment

Wastewater from barge cleaning, bilge wastes, process waters and sanitary wastewater have concentrations of oil and grease typically between 100 and 150 mg/L. The general discharge limit for oil and grease is 15 mg/L. Hence, an oil-water separator is usually employed to separate out the oil from the wastewater. This separated oil can be sold to outside customers for use as fuel.

Secondary Treatment

Biodegradable organics contained in shipyard wastewater can be easily removed using any of the conventional

biological treatment processes or their combination. Several of the available alternatives, namely, suspended growth processes (conventional activated sludge, extended aeration) and fixed-film processes (trickling filters, rotating biological contactors, aerobic fluidized beds) could be selected. The final selection, however, should be based on the review of each of the treatment options in accordance with the wastewater characteristics of the shipyard.

The two common methods of treatment using microorganisms are the activated sludge process and trickling filters. The main methodologies of these units have been described in the following sections. Procedures for unit design, design parameters, and other details can be found in standard wastewater treatment literature (Metcalf & Eddy, 1991; Qasim, 1994).

The Activated Sludge Process

The activated sludge process uses suspended bacteria to assimilate the organic matter present in the waste stream for cellular growth, and in that way, it transforms dead dissolved and colloidal organic matter into live biomass. As the microorganisms grow and are mixed by the agitation of the air supplied to the reactor, the individual microorganisms clump together to form an active mass of microbial floc called “activated sludge” (Qasim 1994). Once the microbial floc is formed it becomes settleable and thus can be separated from the liquid in the sedimentation tank. A significant fraction of the biomass separated at the settling tank is recycled back to the aeration unit to maintain the proper food-to-microorganism ratio, and the excess sludge is wasted to the sludge treatment system.

Although there are several process modifications, the most common type of activated sludge is the complete mix aeration system. The influent and the returned sludge are mixed and applied at several points along the length and the width of the aeration basin. The contents are completely mixed by the aeration system so that the biological oxygen demand is satisfied by the oxygen supplied throughout the tank.

The activated sludge process can be easily employed for treating shipyard wastewater as it does not occupy much space. The treatment process can be carried out in floating tanks placed on a barge. The complete mix system may require heating to enable proper temperature conditions for the microbes to work effectively.

Trickling Filters

The trickling filter consists of a bed filled with crushed stones or synthetic media, with their surface coated with a biological film. Wastewater is applied intermittently on the

filter surface by means of a self propelled rotary distribution arm. The dissolved or colloidal organic substances are removed by the attached biological film, which grows in thickness as bacteria, protozoa and other microorganisms multiply within the film. The microorganisms living at the film surface are exposed to high concentrations of oxygen and substrate, while those developing at the base may receive very low levels of oxygen and substrate. When the film thickness is excessive, the microorganisms living at the base may starve and die-off, the film detaches, and a new growth cycle starts.

The TF process efficiently treats industrial wastes having a high percentage of soluble, small molecule organic material, and readily removes suspended and colloidal organics by the combined process of flocculation, adsorption, and enzyme complexing (WEF, 1991). The versatility of trickling filters towards variations in the wastewater characteristics makes them useful for treating shipyard wastewater as the wastewater from various operations varies with factors like different types of vessels being cleaned, different kinds of processes being employed at times owing to their intermittent nature, and others. Also, the ability of TFs to treat low-strength streams can be utilized for treating shipyard wastewater.

Tertiary Treatment

As part of tertiary treatment, the treatment plant could have filtration to further remove suspended solids, and adsorption, to remove non biodegradable organic compounds that may be toxic to aquatic life. The filtration of effluents from wastewater treatment processes is a relatively recent practice (Metcalf & Eddy, 1991), used for achieving supplemental suspended solids removal from biological or chemical treatment processes.

Carbon adsorption is an advanced wastewater treatment method used for the removal of refractory organic compounds as well as residual amounts of inorganic compounds such as nitrogen, sulfides, and heavy metals (Metcalf & Eddy, 1991). Filtration of effluents through granular activated carbon beds must be preceded by sand filtration to protect the carbon particles against significant pressure loss, channeling or blockages. If powdered activated carbon (PAC) is used, it is usually added to the activated sludge aeration basin, so that biological oxidation and physical adsorption occur simultaneously.

Physico-chemical Treatment

The main difference between the biological treatment plant and physico-chemical treatment is that the latter does not rely on bacteria to remove organic matter from wastewater.

To remove colloidal particles, both organic and inorganic, chemical addition is required. Coagulants added to the wastewater stream will destabilize the colloidal suspensions and floc formation will take place in a flocculator. Dissolved organic substances must be removed by adsorption in activated carbon filters. Thus, the sequence of treatment units in a typical physico-chemical shipyard treatment plant would be the following: preliminary treatment, chemical addition, flocculation, dissolved air flotation, effluent filtration, adsorption of organics, final effluent disinfection and sludge treatment. This section will only describe the new units needed in physico-chemical treatment, namely, flocculation and dissolved air flotation.

Flocculation

The purpose of flocculation is to form settleable particles from the destabilized colloidal particles. The flocculator is a separate reactor, with a holding time of around 30 minutes, where the wastewater is agitated gently with paddles rotating at a velocity between 1.3 and 3.3 ft/s. This gentle agitation will promote particle growth so that the larger floc particles will be easily separated by gravity or by flotation.

Dissolved Air Flotation

The addition of chemical coagulants (alum, polymers) will also destabilize emulsified oil particles and promote the formation of oil droplets; these larger particles can be easily dragged to the surface by the small air bubbles generated in the flotation unit. Dissolved air flotation (DAF) is a wastewater treatment process in which oil, grease, and other low density suspended matter are removed from a waste stream. Ekenfelder (1980) reports that oil tanker ballast water with an oil concentration of 133 mg/L was successfully treated by dissolved air flotation and the addition of 100 mg/L of alum and 1 mg/L of polymer; the effluent oil concentration was reduced to 15 mg/L.

There are three modes of injecting air bubbles into the waste stream: recycling, total pressurization, and partial pressurization. Total pressurization is used in small installations, whereas in larger units, recycle or partial pressurization is usually selected (EPA 1973a, 1973b). With wastewater containing emulsified oil or grease, chemical conditioning is necessary to break the emulsion and form a floc to absorb the oil or grease. The particle growth preceding flotation contributes to the effectiveness of the flotation process. Therefore, when chemical addition is used to break up the emulsion, a flocculation chamber is generally used preceding the flotation process.

In the case of shipyard wastewater, excluding storm water runoff, treatability studies should be conducted to determine

not only the design parameters for the DAF unit, but also to determine whether chemical treatment and flocculation are needed to improve the DAF unit efficiency.

A typical treatment train for wastewater treatment in shipyards is illustrated in Figure 3. Table 1 gives the typical effluent characteristics after treatment and before discharge into the water body.

Other Treatment Options

The treatment procedures described in this section give options to treat either one or a group of pollutants that may occur in the wastewater streams in a shipyard. Some of these options can be integrated with the conventional biological or physico-chemical treatment after assessing their compatibility to these treatment methodologies.

Sodium Nitrite is used for marine steam boiler maintenance operations like hydroblasting cleaning, hydrostatic pressure testing, lay up, and rinsing. The addition of sulfamic acid to wastewater effectively removes sodium nitrite by reducing nitrites to form sodium bisulfate, diatomic nitrogen, and water.

Ferrous sulfate/Sodium sulfide process is used to remove heavy metals from wastewater through precipitation at normal or alkaline pH. Ferrous and sulfide ions act together to reduce hexavalent chromium to trivalent chromium to form a precipitate. The ferrous and sulfide precipitate further removes suspended and dissolved metals through coagulation and flocculation. Sodium hydroxide can also be used for heavy metal precipitation. Sodium hydroxide forms a precipitate that removes heavy metals through coagulation and flocculation similar to ferrous sulfate/sodium sulfide process. Addition of sulfuric acid neutralizes the wastewater prior to discharge.

Activated carbon beds are used to remove toxic organic compounds from wastewater. Costs of handling and disposal of activated carbon waste streams can be high. Carbon regeneration through thermal destruction/scrubbing system destroys organic contaminants and regenerates the carbon for reuse resulting in reduction in disposal costs and also purchase of fresh carbon.

The ultraviolet(UV) oxidation process destroys dissolved organic constituents through chemical oxidation process using UV and hydrogen peroxide. UV light also catalyzes the breakdown of hydrogen peroxide to produce hydroxyl radicals, which are powerful chemical oxidants. Oxidants react with organic matter to produce harmless carbon dioxide, halides and water byproducts. Table 2 gives a summary of the minimization and treatment options

Table 1. Effluent characteristics of a typical wastewater treatment plant effluent

Parameter	Concentration, mg/l
Oil and Grease (O&G)	<5.0 to 8.0
Chemical Oxygen Demand (COD)	39 to 144
Total Suspended Solids (TSS)	6 to 40
Phenols	<0.005 to 0.024
pH	Around 7.0
BTX	BQL
Purgeable Halocarbons	BQL

MQL = Minimum Quantification Level - USEPA Region VI NPDES; BQL = Below MQL

available for shipyard wastewater.

CONCLUSIONS

Various shipyard operations like vessel cleaning, pipeshop operations, solvent cleaning and degreasing and others generate huge quantities of wastewater. The quantities from the process/washwaters in a typical shipyard can be as high as seven million gallons in a year. Such high quantities invariably draw the attention of the shipyard environmental managers to reduce the waste streams.

Pollution prevention is the best sought out method for reducing pollution. Many options are available for reducing the extent of pollution from shipyard processes most of them being source reduction methods. Various methods like process changes, replacement of solvent strippers, alternative cleaning solutions, cleaner abrasive media, efficient rinse systems, effective reuse and recycling options including evaporation, reverse osmosis, electrolysis, and others are viable source reduction methods.

Looking into the characteristics of wastewater from various processes, two alternatives for treatment of oil & grease, COD, TSS, and others were discussed. The biological treatment can employ either the activated sludge process or the trickling filter concept in the secondary treatment. On the other hand, physico-chemical treatment does not involve treatment by microorganisms but will require additional physical processes like flocculation and dissolved air floatation. Implementation of pollution prevention technologies in shipyard could result in cost benefits, regulatory compliance, and increased public image apart from reduction in liability.

REFERENCES

- Eckenfelder, W.W., 1980, *Principles of Water Quality Management*, CBI Publishing Company, Inc., Boston, Massachusetts.
- Environmental Protection Agency, 1973a, *Pretreatment of Poultry Processing Wastes, Upgrading Existing Poultry-Processing Facilities to Reduce Pollution*, EPA Technology Transfer Publication.
- Environmental Protection Agency, 1973b, *In-Plant Modifications and Pretreatment, Upgrading Meat Packing Facilities to Reduce Pollution*, EPA Technology Transfer Publication.
- Environmental Protection Agency, 1994a, *Guide to Cleaner Technologies - Alternatives to Chlorinated Solvents for Cleaning and Degreasing*, EPA/625/R-93/016.
- Environmental Protection Agency, 1994b, *Guide to Cleaner Technologies - Metal Surface Treatment and Plating Operations*, EPA/625/R-94/007.
- Environmental Protection Agency, 1994c, *Guide to Cleaner Technologies - Organic Coating Removal*, EPA/625/R-93/015.
- Kiely, G., 1997, *Environmental Engineering*, McGraw Hill, London, England.
- Kura, B., 1996a, *Integrated Environmental Management Plan - First Year Interim Report*, Gulf Coast Region Maritime Technology Center Project No. AMTC95-008A.

Kura, B., 1997, *Integrated Environmental Management Plan - Second Year Interim Report*, Gulf Coast Region Maritime Technology Center Project No. AMTC95-008A.

Kura, B., and Lacoste, S., 1996b, "Typical Waste Streams in a Shipbuilding Facility," paper No. 96-WP70B.04. GCRMTC, University of New Orleans, New Orleans.

La Motta, E.J. and Kura, B., 1997, *Treatment Alternatives and Construction Costs of Shipyard Wastewater Treatment Plants*, Environmental Resources Information Center, University of New Orleans, New Orleans.

Metcalf & Eddy, 1991, *Wastewater Engineering, Treatment, Disposal, Reuse*, Third Edition, McGraw Hill, New York.

Naval Facilities Engineering Service Center, 1998, *Joint Service Pollution Prevention Technical Library*.

Qasim, S.R., 1994, *Wastewater Treatment Plants, Planning, Design and Operation*, Technomic Publishing Co, Inc., Lancaster, PA.

Water Environment Federation, 1991, *Design of Municipal Wastewater Treatment Plants, Volume 1*, WEF Manual of Practice No. 8, ASCE Manual and Report on Engineering Practice No. 76, Water Environment Federation, Alexandria, Virginia.

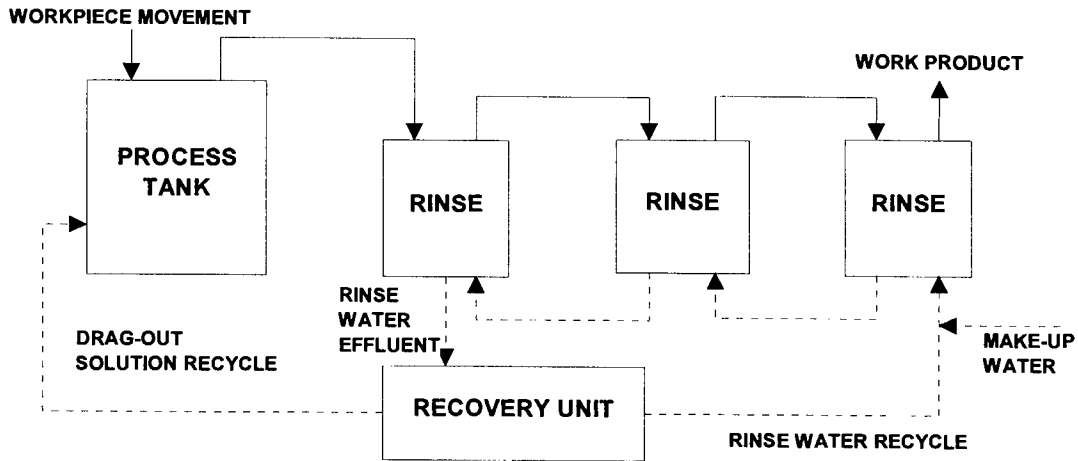

Figure 1. Electro-Dialysis Closed Loop System

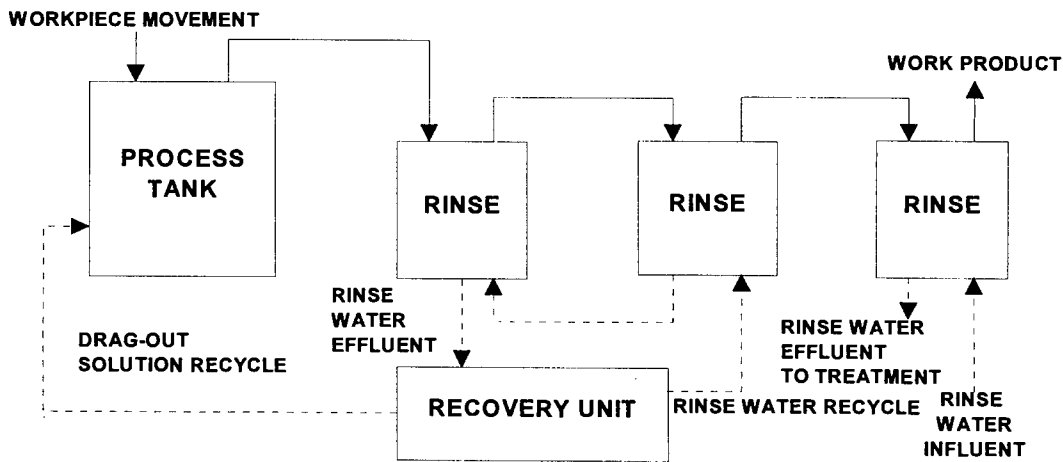

Figure 2. Electro-Dialysis Open Loop System

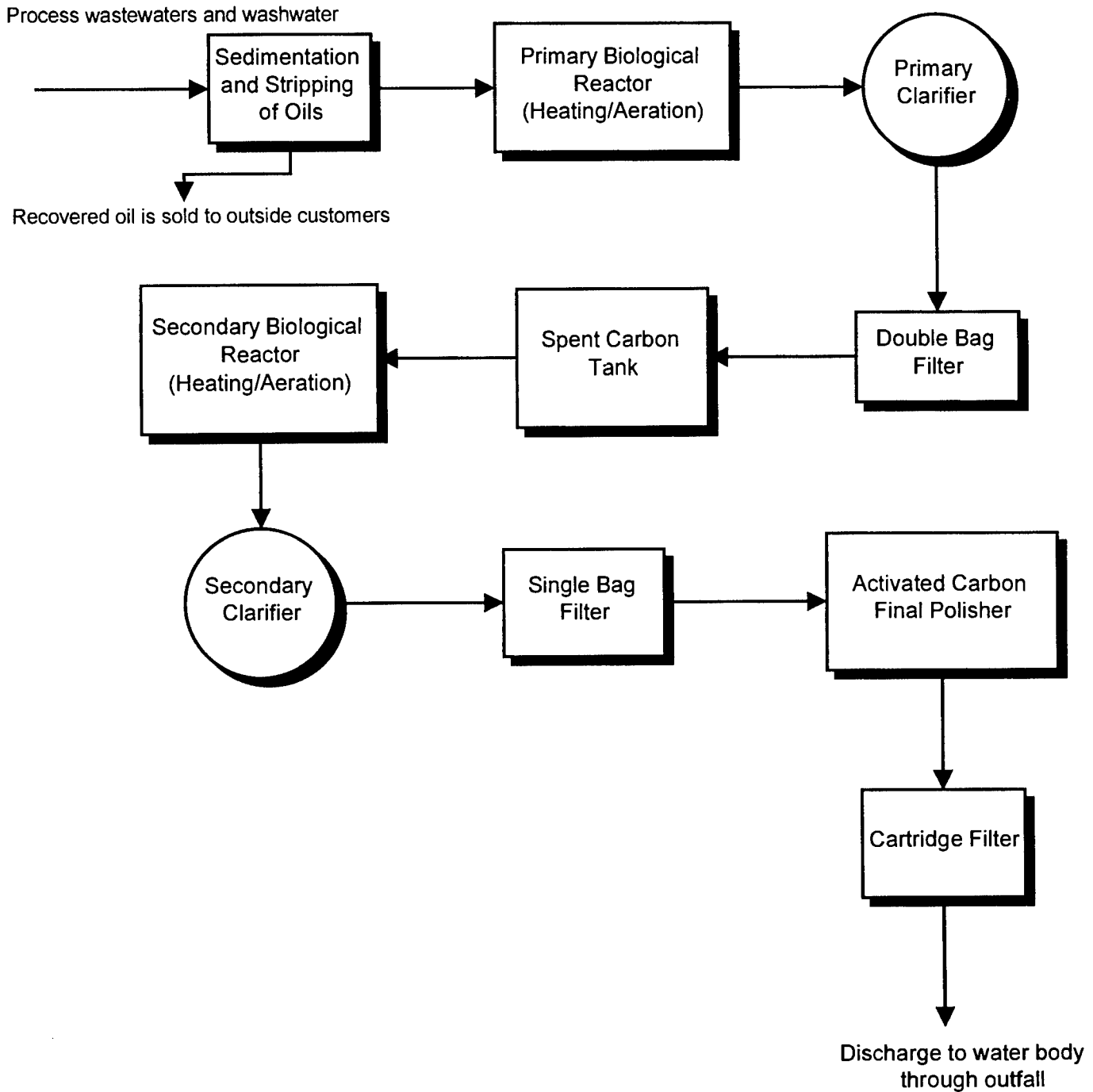

Figure 3. Typical Wastewater Treatment Train for Shipyards

Table 2. Summary of various treatment and waste minimization options available for shipyards*

Treatment	Description	Costs
Sodium Nitrite Removal	Sodium Nitrite is used for marine steam boiler maintenance operations like hydroblasting cleaning, hydrostatic pressure testing, lay up, and rinsing. The nitrite level in the wastewater prohibits discharge of wastewater. The addition of sulfamic acid to wastewater effectively removes sodium nitrite by reducing nitrites to form sodium bisulfate, diatomic nitrogen and water.	Annual savings are \$10 million.
Heavy Metals Removal	<p>1. Ferrous sulfate/ Sodium sulfide process is used to remove heavy metals from wastewater through precipitation at normal or alkaline pH. Ferrous and sulfide ions act together to reduce hexavalent chromium to trivalent chromium to form a precipitate. The ferrous ions acts with the sulfide, aiding in the reduction of chromium at neutral or alkaline conditions. The ferrous and sulfide precipitate further removes suspended and dissolved metals through coagulation and flocculation. Sodium hydroxide may also be added to remove heavy metals.</p> <p>2. Precipitation and microfiltration use a combination of treatments on a variety of wastes. Chemical precipitation of heavy metals is the first step in this process. Precipitates larger than 0.1 to 0.2 micron are filtered in a tubular fabric crossflow filter. Concentrate is dewatered using conventional process. In microfiltration wastes are pumped into polyester tube that produces a high quality filtrate and removes all particles larger than 0.1 to 0.2 micron. Metals are removed by precipitation in a reaction tank by adjusting their pH. Oil and grease are removed by adding adsorbents. Organics and solvents can be removed by AC, or powdered ion exchange resins</p>	<p>Capital costs are around \$250,000, other costs being negligible.</p> <p>Capital Cost is \$1.00 - \$2.00 per gallon per day; O&M cost is \$1.00 - \$2.50 per 1,000 gallon</p>
Oxidation	<p>1. The laser-induced photochemical oxidative destruction (LIPOD) is a method to photochemically oxidize organic compounds in wastewater. The oxidation process uses a UV laser to excite organic compounds in the presence of an oxidant to initiate a chain oxidation reaction.</p> <p>2. Wet Air Oxidation (WAO) destroys toxics in wastewater by breaking down in simpler components. Process is based on the knowledge that organics will oxidize at relatively low temperatures provided oxygen and proper operating pressures are maintained. Applicable to wastewaters containing organics and oxidizable inorganics. Used to oxidize sewage sludge, regenerate spent AC, and treat process wastewaters.</p> <p>3. The ultraviolet(UV) oxidation process destroys dissolved organic constituents through chemical oxidation process using UV and hydrogen peroxide. Contaminants absorb UV light thereby changing their chemical structure or become more reactive with chemical oxidants. UV light also catalyzes the breakdown of hydrogen peroxide to produce hydroxyl radicals, which are powerful chemical oxidants. Oxidants react with organic matter to produce harmless carbon dioxide, halides and water byproducts.</p>	<p>Capital Costs are \$25,000 - \$60,000;</p> <p>Capital cost is \$12 million; O&M cost is \$480,000/yr.</p> <p>Capital cost - \$339,000; O&M cost is \$100,000/yr.</p>

<p>Oil/Water Separation</p>	<p>1. Reverse Osmosis (RO) uses membrane separation systems to remove inorganic salts as well as some organic solvents from wastewater. Reverse osmosis occurs when pressure is exerted on the contaminated solution causing water to flow from the contaminated solution to pure water. Ultra-filtration (UF) is pressure driven membrane filtration process which is used to separate and concentrate macromolecules and colloids from wastewater. UF is a stand alone process or can be used with RO. Used to treat sanitary landfill waste containing organic and inorganic chemicals, solvent-water mixtures, oil-water mixtures.</p> <p>2. Oil/water separators are self contained, automatic treatment systems used for treatment of oily wastewaters. Units use a coalescing pack to promote oil globule agglomeration to enhance conventional gravity separation process. Gravity separation takes advantage of density difference between oil and water. Formation of oil globules is promoted so that their buoyancy increases and they rise to the surface at a faster rate.</p> <p>3. Bilge and Oily Wastewater Treatment System (BOTWS) separates oil from contaminants found in bilge waters. BOTWS is a stationary system. The bilge water is transferred to a large equalization tank equipped with skimmer to remove free oil. After sufficient residence time, the water fraction is selectively removed and fed through a plate coalescer for removal of free oil. The water is fed into the chemical treatment chamber where sodium hydroxide and anionic polymer are added and mixed. This results in breakdown of emulsion and precipitation of heavy metals. The heavy metals are removed in an induced-air flotation unit.</p>	<p>Capital cost is \$450,000 for a loading of 40,000 gpd; O&M cost is \$194,800/yr.</p> <p>Capital cost is \$30,000 for 10 gpm unit; O&M cost is \$96,400/yr including labor.</p> <p>Capital costs are \$1,400,000; O&M cost is \$155,000/yr.</p>
<p>Biological Treatment</p>	<p>1. Bio Trol BioAccelerator uses microbes to degrade contaminants in wastewater. The pH is adjusted and inorganic nutrients are added. If necessary the water is heated to optimum temperature. The heated water flows into a multiple cell, submerged, fixed film bioreactor. The cell is filled with packing material to which the microbes adhere. For aerobic conditions air is supplied by fine bubble diffusers at bottom of cell.</p> <p>2. Powdered Activated Carbon (PAC) combines biological treatment with adsorption method. Typically, PAC contact wastewaters in an aeration basin. Biomass removes biodegradable organic contaminants through biological assimilation and carbon physically adsorbs conventional and toxic organics. Applicable to end-of-pipe treatment of industrial wastewaters, combined municipal/industrial wastewaters, contaminated surface runoff and groundwater, and landfill leachates.</p>	<p>Capital cost is \$150,000; O&M costs are \$21,300/yr including labor.</p> <p>Capital costs are \$100,000 - \$300,000 for mobile units; O&M cost varies from \$0.50 to \$1.00 per 1,000 gallons.</p>

Reuse	<p>1. Secondary use of acids and alkalis as treatment chemicals in wastewater treatment for neutralization. Replaces treatment chemicals like sulfuric acid and sodium hydroxide in chromic reduction, cyanide oxidation, metal precipitation and neutralization processes.</p> <p>2. Activated carbon beds are used to remove toxic organic compounds from contaminated groundwater, wastewater. Cost of handling and disposal of activated carbon waste streams can be high. Carbon regeneration through thermal destruction/scrubbing system destroys organic contaminants and regenerates the carbon for reuse.</p>	<p>Capital Cost is \$14,112/yr; labor cost is \$8,100/yr.</p> <p>Capital cost is \$16,860/yr.</p>
Recycling	<p>1. Cutting fluid recycling system is based on the centrifugal removal of contaminants which will treat 60 to 300 gallons of cutting fluid per hour. Cutting fluid recycling systems incorporate filtration, centrifugation, pasteurization, oil skimming, and/or coalescence processes. The unit includes the following options: a self-cleaning centrifuge, a proportional mixer system, a heat exchanger, processing tankage, a clean coolant distribution system, and water deionizer.</p> <p>2. Wastewater Recycling: A closed loop wash rack contains and treats wastewater generated from washing vehicles, construction equipment, and aircraft. A typical process flow for water recovery system comprises of a first unit separates free oil and dirt from wastewater. The second unit removes fine dirt particles and remaining hydrocarbons. The next unit stores the water in a holding tank for reuse.</p>	<p>O&M cost is \$6,500/yr; labor cost is \$2,200/yr.</p> <p>Capital cost is \$10,430/yr; O&M cost is \$550/yr including labor.</p>
Process Modification/ Material Substitution	<p>1. Mechanical cleaning process reduces waste production and eliminate potential safety problems with the handling and usage of toxic, ozone depleting, and often flammable solvents. The mechanical work of cleaning operations include 1) Brushing, using wire or plastic brushes, 2) Grinding, using a rotating abrasive stone or disc, 3) Polishing and buffing, using a soft device like a fabric or fiber cloth, and 4) Sanding, using a fiber sheet embedded with sand or other mineral grit particles that removes surface dirt or loose paint.</p> <p>2. Heat is primarily used in the steam cleaning process. Heat accelerates emulsification, breakdown, and removal of caked-on dirt and grease. High temperature is maintained on the surface long enough for the steam to vaporize or liquefy the oil, grease, or dirt.</p> <p>3. Uses sonic vibration to produce cavitation bubbles in liquid medium which removes contaminants.</p>	<p>Capital cost is \$420; O&M cost is \$1,468/yr; labor cost is \$345,600/yr.</p> <p>Capital cost is \$5,000; O&M cost is \$700/yr; labor cost is \$7,800/yr.</p> <p>Capital cost is upto \$180,000.</p>

* Various assumptions went into estimation of costs details of which can be obtained from the source: Naval Facilities Engineering Service Center, 1998, *Joint Service Pollution Prevention Technical Library*.

Using Ground Recycled Glass in Abrasive Blasting to Reduce Shipyard Contamination

Fred Miller
TriVitro Corporation
18250 68th Avenue South
Kent, WA 98032
(425) 251-8340 fax 251-8301
fmiller@trivitro.com

ABSTRACT

Recent developments in the use of ground recycled glass as an abrasive blasting media show that the material is a viable substitute for commonly used slag and mineral abrasives. Because of its physical properties, density and angularity, ground glass offers distinct performance benefits. With no free silica and no heavy metals, the critical advantages to ground recycled glass are in the areas of environmental compliance, toxics and waste reduction, and worker safety.

Keywords: Abrasives, abrasive blasting, surface preparation, coating removal, ground recycled glass, industrial hygiene, shipyards, dry docks.

INTRODUCTION

As participation in recycling programs grows in North America, significant quantities of recycled glass are being generated beyond the capacity for bottle plants to absorb the material back into production. Hence, there is a strong need to develop new markets for recycled glass. For over ten years, glass processors have slowly introduced finely ground recycled glass into the abrasive blasting industry. Within the last three years, market acceptance of the use of ground recycled glass abrasives has grown sharply as new information is developed about the productivity, environmental and safety benefits of this technology. In 1999, NAVSEA listed the first ground recycled glass on its Qualified Products List (QPL) under its specification MIL-A-22262-B(SH), Abrasives, Ship Hull Blast Cleaning.

Recent test data, including a major study of abrasives by NIOSH, point to the fact that ground recycled glass offers a safer, productive alternative media for use in shipyards.

PROPERTIES OF GROUND RECYCLED GLASS

At an approximate bulk density of 80 lbs. per cubic foot and a Mohs hardness of 6.0, ground glass is an inert, amorphous material well suited to an abrasive media application. Processing systems are in place in several North American locations to produce consistently sized, angular to sub-angular grain sand from recycled glass. With proper grinding, drying, and screening, the finished product will be a clean, contaminant free sand-like material.

In stark contrast to commonly used mineral and slag abrasives, ground glass contains virtually no heavy metals. Insignificant quantities of contaminants from the recycling stream should be substantially removed during the manufacturing process. Achieving approval under the NAVSEA specification is proof that this media can meet demanding environmental specifications. NAVSEA test results indicated exceptionally low levels of chlorides, organics and conductivity in addition to the relative absence of 17 tested metals.

Because glass is amorphous, there is no crystalline structure to the silica or other ingredients of glass, nor can crystalline silica be created by simply breaking glass particles down to finer sizes. The

absence of free silica in an abrasive media is a significant benefit, as OSHA, NIOSH and state industrial hygiene agencies continue to warn about the silicosis risks associated with blasting with silica sand and other abrasives containing free silica.

INDUSTRIAL HYGIENE

Recently NIOSH completed a three-year study {Evaluation of Substitute Materials for Silica Sand in Abrasive Blasting, NIOSH, Sep 1998, Report No. PB99105553, available from <http://www.ntis.gov>, <http://www.cdc.gov/niosh/homepage.html> or 800-553-NTIS} of a wide range of slag and mineral abrasives in an effort to evaluate the effectiveness and industrial hygiene of alternatives to silica sand for abrasive blasting. A summary of the study was published in the August issue of the *Journal of Protective Coatings and Linings*. After extensive performance and safety tests of 40 samples of 13 different types of abrasives, including crushed glass, the NIOSH report calls for fundamental re-consideration of the safety of abrasive blasting with most of the slag and mineral products commonly used. The findings of the study were striking in the occurrence and extraordinary concentrations of heavy metals present in airborne dust from blasting with copper, nickel and coal slags, as well as several other mineral abrasives.

For instance, the geometric mean concentration of all arsenic detection tests during copper slag blasting was $89.1 \mu\text{g}/\text{m}^3$, 9 times greater than OSHA regulations allow. Similarly, the geometric mean concentrations of chromium detection test during nickel slag blasting was $811.8 \mu\text{g}/\text{m}^3$, 62% higher than the OSHA PEL for chromium. As a result of finding these and many other high concentrations of hazardous health-related agents in slag and mineral abrasives, the NIOSH report recommendations include:

1. "In order to reduce the airborne concentrations of the eleven hazardous health-related agents, consider the use of crushed glass..."
4. "Given the potential exposures to multiple contaminants from both the abrasive, as well as the painted surface, worker protection programs should be expanded to address all potential metals (e.g. as opposed to the current

focus on worker lead protection programs)..."

6. "Evaluate the potential for correlations between the concentration of health-related agents in all virgin abrasives and in particular coal slag, copper slag, garnet and steel grit, and the resulting airborne concentrations, for use as a selection criteria."

ENVIRONMENTAL CONSIDERATIONS

The NIOSH report documents, from an industrial hygiene perspective, serious heavy metal concentrations in commonly used abrasives. Beyond risks to workers, these heavy metals may present unnecessary environmental risks as well. Detected total levels of heavy metals increased significantly in the airborne dust from abrasive blasting. Considering shipyard needs to manage and control spent abrasives, fugitive dusts, dry dock and shipyard storm water, and spills, the availability of an alternative media with no heavy metals can offer significant benefits to shipyard operations. Additionally, as federal agencies seek out the use of recycled and environmentally preferable products, provision of 100% recycled glass media offers unique solutions.

Because of its performance characteristics, ground glass also offers significant potential for waste reduction. Most blasting operations report using between 30% to 50% less media compared to copper slag abrasives. Less media consumed is less media requiring disposal. Notably, in some cases where the media is used on a clean, inert surface, the spent abrasive is used as a soil amendment or left on site, since there are no leachable heavy metals for concern. Otherwise, spent glass abrasives may be safely disposed of in landfills or asphalt plants, in accordance with applicable waste regulations.

PERFORMANCE ISSUES

Ground glass has its own set of unique performance characteristics. Because they are relatively lighter and sharper than common abrasives, ground glass abrasives perform very well in coating removal applications such as epoxies, alkyds and enamels, and especially thicker, softer or rubbery coatings. Conversely, because of glass' lighter density, removal

of harder or tougher coatings, heavy rust, or thick mil scale requires particular operator skills and approaches in order to be successful. While conventional abrasive blasting equipment can be used, attention must be given to properly setting air pressures and metered flow rates in using the abrasive.

Ground glass shows very little embedment in steel, and dust from blasting with it is lighter and easier to evacuate from the work area. Engineers and consumers of blasting services are concerned about the condition of surfaces, particularly steel, prior to coating. The amount of embedment, chlorides content, metals content and conductivity of abrasives are of concern because of the potential for rusting or other causes of coating failure. It is reasonable to assume that, regardless of operators' skill or diligence, risks for costly coating failures due to embedment, chlorides, conductivity, or traces of metals will be greatly reduced through the use of recycled glass abrasives.

Ground glass is unique in its ability to economically clean aluminum, brass, copper, and stainless steel with little to no substrate damage. Until the use of this type of abrasive, these types of surfaces had to be cleaned with garnet, baking soda, glass bead, walnut shells, or other media – all of which are several factors more expensive than ground glass. The light,

aggressive nature of ground recycled glass allows for very productive cleaning without staining, warping, excessive profiling or surface damage. Properly used, ground glass shows strong advantages in “spot” and “sweep” blasting because it tends to be less damaging to surrounding painted areas, leaving smoother surfaces and more gradual feathered edges.

Shipyards engineers, specifiers and operators must have sufficient knowledge of project conditions to “pre-qualify” the types of abrasives allowed. In certain applications, such as those mentioned above, ground glass shows significant performance advantages. Ground glass has the potential to replace many slag and mineral abrasives for a range of common de-painting and rust removal tasks. In general abrasive blasting work, it is competitive in price and performance with these bulk abrasives. In the whole consideration, including environmental and worker safety aspects, ground glass abrasives can provide unique and distinct advantages for shipyard operations.

Further information about the Navy QPL listed ground glass abrasive, see <http://www.trivetro.com>. Because the development of abrasives markets is important to the future of recycling, the Clean Washington Center sponsored independent evaluations of ground glass abrasives. Test reports are available at <http://www.cwc.org> (click on “publications” and “glass.”).

Environmental Enclosure Systems for Industrial Ship Applications to Prevent Emissions and Discharges

Douglas A Randall¹

ABSTRACT

The Department of National Defense, Fleet Maintenance Facility on Cape Scott, in Halifax, NS is a large Industrial Ship Repair Facility that is owned by the Canadian Government and operated by the Navy. The facility has an ISO 9001 Quality Management Certification and has also achieved an ISO 14001 Environmental Certification. The facility has a work force of approximately twelve hundred people with a focussed role of maintaining the operational readiness for the Navy. The challenge to the facility is to protect the environment and conform to all the latest environmental regulations that have been legislated by all levels of government. Further to these regulations the Navy has also written guidelines that regulate the way the Navy does business with regards to the environment. Initially, the ship repair facility feared that the introduction of new environmental policies may put it out of business. This has not been the case, as on average only three percent of the total cost of the refit has been spent on protecting the environment during the

refit process. It is important to note that the emphasis of the facility has been from the beginning to prevent the discharge of effluents into the marine aquatic environment.

Keywords: National Defense Fleet Maintenance Facility, Cape Scott, Halifax, NS, Environmental Regulations, ISO 9001, ISO14001, Discharges, impact (operations and costs of regulations and policy).

INTRODUCTION

The DOD Fleet Maintenance Facility is a large Industrial Ship Repair Facility that is owned by the Canadian Government and operated by the Navy. We have an ISO 9001 Quality Management Certification and have also achieved an ISO 14001 Environmental Certification. We have a work force of approximately twelve hundred strong with a focussed role of maintaining the operational readiness for the Navy.

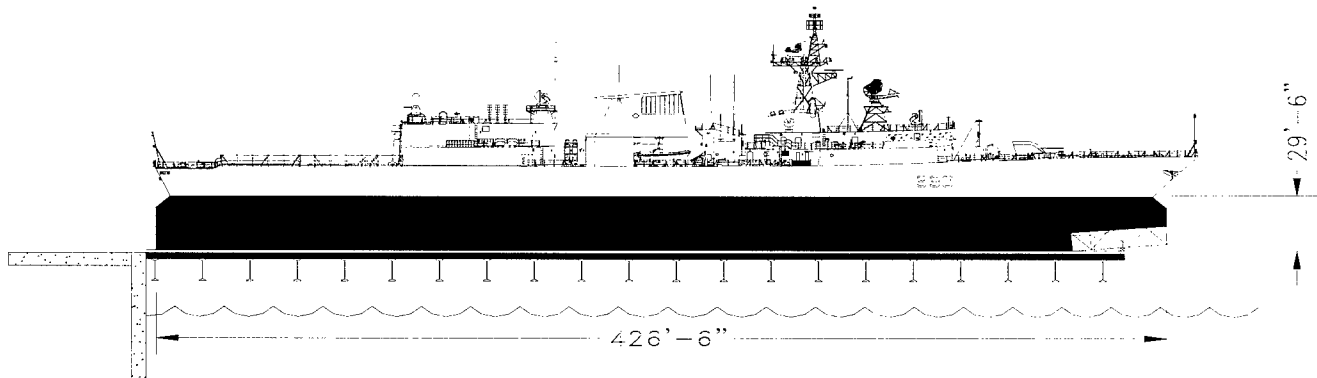

CHALLENGE

Our challenge is to protect the environment and conform to all the latest environmental regulations that have been legislated by all levels of government. Further to these regulations the Navy has also written guidelines that regulate the way we do our business with regards to the environment. Our fear as a ship repair facility was that the introduction of

new environmental policies may put us out of business. This has not been the case as on average only three percent of the total cost of the refit has been spent on protecting the environment during the refit process. It is important to note that the emphasis has been from the beginning to prevent the discharge of effluents into the marine aquatic environment.

¹ Department of National Defense, Fleet Maintenance Facility Cape Scott, PO Box 99000 STN Forces, Halifax, NS B3K-5X5, Ph (902) 427-0550 Ext 2663, Fax (902) 427-2666, Email: drandall@fmfcs.hlf.dnd.ca

REGULATIONS

FISHERIES ACT, RSC 1985c,F-14; Available on the Internet under URL, <http://canada.justice.gc.ca/ftp/en/laws/chap/f/f-14.txt> Maritime Command Orders, G-18, See ANNEX A Attached.

ENVIRONMENTAL IMPACT

During refits, our naval vessels are raised out of the water using a syncrolift. Increased environmental regulations were introduced into the work environment that had a direct impact on how we were to conduct our business during the refits. It was clear that an effective plan was going to have to be developed and a design conceived that would allow us to stay an industry leader and to protect the environment.

EVOLUTION OF A PROCESS

In the beginning the only requirement was to contain grit blast media in the form of aluminum oxide and the by-products that included lead based paint, antifouling, tributyltin, etc. This containment process was complicated by the fact that our work area was directly above the water on a syncrolift that extends four hundred and fifty feet out over the water. This process evolved into the complete capture of all liquids that were generated from the hydro blasting process that amounted to thousands of gallons. Further development of the process was to include capture of all particles generated from blasting and sanding of all areas above the waterline. The original systems consisted of loosely suspended tarps that were supported by sparsely spaced scaffolding and somewhat attached to the ships hull. The enclosure system has now evolved onto a rigid structure that has stood gale force winds in excess of seventy miles per hour without damage. This has been achieved by using an elaborate scaffolding and tarp system that is self-supporting in that no pressure is asserted on the hull in a high wind situation.

DESIGN AND CONSTRUCTION

The design and construction of the enclosure and capture system was developed in accordance with all applicable codes and regulations that include the Fisheries Act, Fire and Safety regulations, National Building and Electrical codes, Federal and Base environmental regulations and site authority inspections on quality. Specifications were developed that detailed the requirements of the work and the steps to be followed during construction. The purpose of the enclosure and capture system is twofold; one, to maintain sufficient temperature in winter and two, to allow for the capture of all liquids and particles generated during the refit. A comprehensive list of applicable materials had

to be researched prior to writing the specifications. Sufficient latitude was given that, in consultation with the contractor new innovations could be explored. The specifications were written in a manner that would make the applicable contractor responsible for the end result. Attached is a specification that was developed to enclose HMCS Charlottetown that was dry-docked during the months of June through July 1999; See ANNEX B Attached.

WEATHER

Our Facility is located in eastern Canada in the province of Nova Scotia. The weather conditions in summer are quite pleasant with prevailing winds that are light and, usually from the southeast. In winter, conditions can change rapidly with high winds and temperatures well below freezing. These low temperatures can pose problems in dealing with liquids that freeze at thirty-two degrees Fahrenheit. It is common to have wind in excess of seventy-five miles per hour accompanied by rain or snow. The design phase had to take into consideration that high wind would impact on the enclosure and that low temperatures would necessitate the need for heat. Weather conditions played a major part in selecting materials that would make the structure sound.

COST EFFECTIVE

During the initial development of the environmental process we have designed and implemented, there were concerns that the process would put us out of business. We have since come to learn that this is not the case. In fact the environmental portions of the last two major refits that we have done amounted to only three percent of the total budget to build a containment system. We have also had situations where we utilized the same capture system on more than one occasion thus further reducing our cost. Shown on page three is a chart that shows the percentage associated with protecting the environment in relation to the cost of the total refit of the vessel.

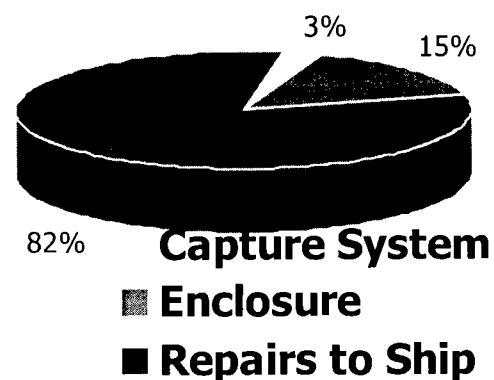

ANNEX A

Listed below are the Naval orders that govern how we are to conduct business in relation to protecting the environment.

MARITIME COMMAND ORDERS SHIPBOARD ENVIRONMENTAL MANAGEMENT

PART I - GENERAL POLICY AND DIRECTIVES

References:

- A. MARCORD 4-12 Maritime Command Environmental Program
- B. CF and DND Policy on the Environment P5/92
- C. CFAO 4-13 Reporting of significant incidents
- D. CFTO C-81-011-000/MG-001- Operating and Maintenance Instructions - Oil tank and Bilge Cleaning Chemicals
- E. C-03-005-033/AA-000 Naval Engineering Manual, Vol 1
- F. MARCORD 66-5 Hazardous Material Management Program
- G. MARCORD 66-9 Radioactive Material

Aim

1. This MARCORD provides guidance to ships on environmental management of shipboard waste.

Background

2. This MARCORD supersedes all pollution control management directives previously generated by MARCOM and it is complementary to the policy at reference A.

Scope

3. This MARCORD contains direction on environmental management of all waste for ships at sea and in harbour. The guidance provided herein reflects national and international regulations and conventions. The MARCORD is divided into three parts and the following areas of environmental management are addressed:

- a. Part I: General Policy & Direction;
- b. Part II: Waste Management; and
- c. Part III: Fueling.

General Policy

4. As directed at reference B, MARCOM will demonstrate responsiveness to and responsibility for protecting the environment in the conduct of all activities; and will adopt a sound environmental ethic, ensuring responsible partnership in the Government's overall environmental program. Specifically, it is CF, DND and MARCOM policy that the letter and spirit of all applicable federal environmental laws shall be met or exceeded and, whenever possible, compatibility with provincial and international standards shall be ensured. The MARCOM environmental policy is to be reflected in all pan-naval activities and operations. This MARCORD shall be fully adhered to except:

- a. when national security is threatened or when operating under the National Emergency Act; and
- b. for the purpose of saving life or preventing the immediate loss of a ship.

5. Annex A provides an overview of applicable pollution regulations. The *Canadian Environmental Protection Act (CEPA)*, the *Canada Shipping Act (CSA)* and the International Convention for the Prevention of Pollution from ships at Sea (MARPOL 73/78) were used in the development of this MARCORD. Annex B is a glossary to assist in the interpretation of various terms used throughout this MARCORD.

6. Commanding Officers (COs) shall take all reasonable measures to ensure their vessels comply fully with local harbour pollution regulations, unless specifically exempted by local port authorities.

NOTE: 1. As the principal pollution related tenets of the *Fisheries Act* parallel those of the *Canada Shipping Act (CSA)*, for simplicity, the definitions contained within the *CSA* are considered representative of both for the purposes of this MARCORD.

2. Any Unit, which is unable to comply with this policy because of equipment deficiencies or limitations, or any other factors, shall report the circumstances in writing through the chain of command.

PART II - WASTE MANAGEMENT

Liquid Waste

7. For the purpose of this order, the liquid wastes generated by ships are of the following types:

- a. oily waste water;
- b. black water;
- c. grey water; and
- d. ballast water.

Oily Waste Water

8. The oil pollution prevention requirements of this MARCORD are based upon provisions of the CSA's Oil Pollution Prevention Regulations which came into effect in 1993 and parallel Annex I of MARPOL 73/78. Oily waste water shall only be discharged overboard after treatment with oil separating or oil filtering equipment, and only under the following conditions:

- a. if the post filtering and/or treatment oil content is:
 - (1) less than 5 parts per million (ppm) in inland waters; and
 - (2) less than 15 ppm outside inland waters; and
 - b. until 6 Jul 98, ships put in service (see Annex B) before 6 July 93 are permitted to discharge oily mixtures with an oil content up to 100 ppm, but only beyond 12 nm of any coastline (excepting in MARPOL special areas).
9. Equipment. The following equipment is deemed to meet the levels mentioned in paragraph 8 of part II:
- a. only those oily water separators fitted with an oil content monitor (OCM) and recirculation line that prevent effluent exceeding 5 ppm from being discharged overboard shall be deemed capable of meeting the 5 ppm oil discharge levels; and
 - b. only those oily water separators fitted with an OCM and recirculation line that ensure oil discharge remains below 15 ppm is deemed to be oil filtering equipment that meets the 15 ppm oil discharge levels.

10. Ships not fitted with oily water separators or with inoperable OCMs, shall post a sentry to ensure discharge from the OCM remains clear and free of visible

contamination (i.e. oil sheen visible in effluent with >15 ppm oil content).

11. Ships planning to visit/transit Arctic waters or MARPOL Special Areas (defined in Annex B) should contact their respective Formation Environmental staff for specific guidance.

12. Ships not equipped to meet the above effluent discharge levels, shall, within ship safety considerations, retain this oily waste water on board until it can be discharged to an appropriate reception facility.

13. Bilge Water. Ships' COs shall:

- a. ensure that discharge to the bilge and bilge water levels are actively controlled to decrease the volume of oily waste water requiring processing;
- b. prohibit discharge of machinery space oily waste water through an oily water separator in excess of the prescribed limits outlined in Part II, Paragraph 8; and
- c. prohibit use of the oily water separator unless the ship is underway and outside of environmentally sensitive areas which include the following:
 - (1) MARPOL Special Areas;
 - (2) Australian Great Barrier Reef; and
 - (3) Arctic Ocean.
- d. be personally responsible for authorizing the pumping of machinery space bilges directly overboard, i.e. not through an oily water separator.
- e. ensure that chemical cleaning agents for cleaning tanks and bilges are used **only** when conditions permit transfer to a sullage barge or other facility designed for their acceptance. (Fluids containing such agents are considered to be contaminated. As such, they shall not be pumped overboard under normal circumstances. References D and E provide further direction on approved cleaning agents.)

Black Water

14. Present Canadian marine pollution prevention regulations only prohibit the discharge of black water in the Great Lakes. To comply with international standards, this section is also based on the provisions of MARPOL 73/78, Annex IV. Black water discharge regulations are outlined in the table at Annex A.

15. At Sea. Ships fitted with black water collection and/or treatment systems shall comply with the following regulations pertaining to black water discharge:

- a. within 4nm of any coastline discharge permitted from treatment systems only;
- b. between 4-12nm (Canadian Waters): discharge of untreated black water permitted, subject to the provisions of paragraph 18;
- c. between 4-12nm (Other coastlines): discharge permitted from treatment systems; and
- d. beyond 12nm of any coastline, ships are permitted to discharge all untreated black water overboard, subject to the provisions of paragraph 18.

16. In Harbour. Ships shall comply with local port regulations. Ships fitted with blackwater collection systems and/or treatment systems shall:

- a. collect and discharge their untreated black water directly to a port facility if such facilities are available and their use is cost effective;
- b. if permitted by local port authorities, discharge black water directly overboard. Such discharge should not be instantaneous but be done at a moderate rate, using the fitted discharge system;
- c. collect black water for discharge at sea in accordance with paragraph 18, if the holding capacity so permits.

17. Due to the high cost of operation and maintenance associated with blackwater treatment systems, ships shall normally limit the operation of such systems to the following circumstances:

- a. when harbour authorities prohibit the discharge of untreated black water, and reception facilities are not available;
- b. when within regulated areas as outlined in paragraph 15 for periods which exceed the holding capacity of the vessel; and

NOTE: Operation of black water treatment systems is not necessary beyond 12nm of any coastline, except in special areas.

- c. when in home port, vessels shall not normally operate their treatment systems. The exception to this is vessels fitted with biological treatment systems, which are designed to run on a continuous basis.

18. When at sea, black water that has been stored in holding tanks shall be discharged at a moderate rate while the ship is underway and proceeding at a speed of 4 knots or greater. It shall not be discharged less than the limits outlined in Annex A.

Grey Water

19. The environmental impact of grey water is minimal, provided no hazardous waste or chemicals have been mixed with it. Grey water is not presently regulated by the Canada Shipping Act or by MARPOL 73/78; however, a growing number of port authorities worldwide do regulate its discharge.

20. Grey water containing hazardous waste shall not be discharged overboard. To reduce the volume/limit the impact of grey water discharge, ships shall:

- a. use soaps, detergents and cleaning agents supplied by the CFSS or their equivalent; and
- b. limit the overboard discharge of fire fighting foam to that amount required to prove proper system functioning during trials or drills. Fire fighting foam shall not be discharged within harbour limits except in case of emergency or where specifically authorized by the appropriate HQ.
- c. cleaning products, including soaps and detergents, are to be CFSS approved and/or equivalent or must be subjected to the review process outlined in paragraph 39(h).

Ballast Water

21. Due to the potential for the unwanted introduction of aquatic organisms and pathogens into foreign ecosystems, the following guidelines must be followed:

- a. when ballasting and deballasting must occur, they are to take place outside of territorial waters in water greater than 200m in depth;
- b. where ballasting/deballasting is necessary outside of the restrictions given in Paragraph 21(a), notification is to be provided to the Formation as soon as practical. The Formation will provide ballast disposal or pumping disposal instructions.

Solid Wastes

22. Categories. Under the provisions of MARPOL 73/78, the solid waste generated by ships is separated into the following categories:

- a. plastics, such as synthetic ropes, styrofoam, and plastic garbage bags;
- b. garbage, such as floating dunnage, lining and packing materials, paper, rags, glass, metals, bottles, crockery, and similar refuse; and
- c. food waste.

23. Disposal. Guidelines for the disposal of solid waste at sea are as follows:

- a. plastics shall not be disposed of at sea;
- b. non-pulped garbage shall not be disposed of at sea within 200nm of Canadian coastlines, anywhere in MARPOL special areas or within 25nm of other coasts. Where practical all non-pulped garbage should be retained on board for disposal ashore. If garbage is disposed of outside regulated limits, it should be made negatively buoyant prior to disposal. Plastic bags are not to be used for disposal;
- c. pulped garbage shall not be disposed of within 3nm of coastlines or anywhere in MARPOL special areas;
- d. pulped food waste shall not be disposed of within 3nm of coastlines, or within 12nm when in MARPOL special areas (unless operational requirements dictate otherwise); and
- e. non-pulped food waste may not be disposed of within 12nm of coastlines, including MARPOL special areas.

24. Recycling. Recycling is an integral component of an effective solid waste management program and contributes to the sustainability of our natural resources. All ships are fully encouraged to practice the 3 Rs of waste reduction (Reduce, Reuse, and Recycle) on board and to make maximum use of recycling programs and facilities where available.

Biohazardous Infectious Wastes

25. Biohazardous Infectious Waste (BIW) includes both medical and dental waste. While it represents a small proportion of a ship's total volumetric waste generation, it

requires proper handling and disposal because of environmental, aesthetic and occupational concerns and its potential hazard to human health.

26. This section outlines procedures for the storage and disposal of BIW.

27. While any item that has had contact with blood, exudation or secretions may pose a hazard, it is usually considered impractical or unnecessary to treat all such waste as BIW. Thus the following items should be considered solid waste and not BIW: sponges, surgery drapes, lavage tubes, casts, disposable pads, disposable gloves, specimen containers, lab coats and aprons, and dialysis waste such as tubing, filters, towels and disposable sheets.

28. The ship's senior medical authority shall determine what constitutes BIW. The ship's CO is the approving authority for its storage and disposal.

29. BIW Holding Bags. Plastic bags used for this waste must be durable, puncture resistant, and able to withstand autoclaving. They shall be colour coded in accordance with the table below. All BIW shall be autoclaved and double bagged prior to storage and subsequent disposal.

30. Colour Coding for BIW Containers:

WASTE TYPE	COLOUR-CODING
Human Anatomical	Red
Microbiology Laboratory Waste	Yellow
Human Blood and Body Fluid Waste	Yellow
Waste Sharps	Yellow

NOTE: Ships shall acquire the proper BIW bags and containers from the CFSS.

Storage

31. BIW shall be stored in accordance with the following directives:

- a. storage areas must be totally enclosed and separated from supply rooms or food preparation areas;
- b. the storage areas must be secure to prevent unauthorized entry;
- c. the WHMIS biohazard symbol shall be prominently displayed on all containers designated for BIW;
- d. no materials other than waste are to be placed in the same storage area as BIW; and

e. whenever possible, BIW should be refrigerated at 4°C until final disposal.

32. Waste sharps shall be collected in plastic autoclavable sharps containers. To prevent accidental puncture wounds sharps should not be recapped, clipped, cut, bent or otherwise mutilated. All sharps shall be steam sterilized and retained on board for proper disposal ashore.

Disposal

33. All BIW aboard ships must be decontaminated by autoclaving prior to its final disposal. The overboard discharge of BIW is prohibited except under the provisions of paragraph 4 of Part I of this MARCORD. All dumping or discharge of BIW shall be the subject of a pollution incident message/report in accordance with reference C and directions from the appropriate Formation.

34. BIW must be disposed of in accordance with local disposal regulations. Such disposal will not be authorized except where appropriate local regulations apply and are in concert with the intent of Canadian environmental guidelines.

Hazardous Wastes

35. Hazardous Waste has the potential to adversely impact human health and the ecosystem in general. Every effort shall be made to prevent hazardous waste from entering other waste streams on board ship. Specific regulations governing the overall management of hazardous materials are contained in reference F.

Categories/Types

36. Hazardous material includes all dangerous substances, dangerous goods, hazardous commodities, hazardous products, and hazardous waste including, but not limited to, the following:

- a. explosives;
- b. gases;
- c. flammable and combustible liquids;
- d. flammable solids (i.e. those readily combustible on exposure to air, water, or water vapour);
- e. oxidizing substances and organic peroxides (including chemox canisters);
- f. poisonous and infectious substances;

g. radioactive materials;

h. corrosives; and

i. miscellaneous (e.g. asbestos, PCBs, and any hazardous waste not ascribable to other categories).

NOTE: Radioactive Material, PCB, and explosives on board ships are not covered in this MARCORD but are covered in references F and G.

37. Hazardous waste shall not be dumped overboard except under the provisions of paragraph 4 of Part I of this MARCORD. Should it be necessary to dump hazardous waste, a pollution incident message/report shall be made to the appropriate Formation headquarters in accordance with reference C and Formation directions.

Return of Hazardous Materials

38. Current environmental legislation requires that hazardous materials be managed responsibly, ensuring the safety and well being of individuals and the environment. All ships are directly responsible for the proper care and handling of hazardous material from the moment it is delivered to its final acceptance by the supporting base or station as returned stores or waste. Essential elements of this management strategy include proper identification, labeling, and packaging prior to handling or transportation for return and disposal.

Handling of Hazardous Materials/Wastes

39. Many of the actions taken to ensure individual safety will contribute to environmental protection. The following factors shall be considered by all personnel who have a requirement to handle hazardous materials/wastes:

- a. ensure that each container is **clearly WHMIS labeled** to identify contents;
- b. ensure that the containers used are in good condition, are compatible with the material to be stored, have proper lids, caps, etc., and do not leak;
- c. ensure that any containers temporarily stored outside without overhead cover are regularly inspected to guard against deterioration, loose lids, tops, etc., which could allow the contents to be released into the environment. These inspections should be logged. (Particular problems are created as the sun heats and expands the contents or as rain water enters containers causing overflows);

d. ensure that all pans or pails used to drain hazardous waste are completely emptied into appropriate containers. (Extra care must be exercised to ensure that drain pans are not left partially filled and exposed to rain which can cause an overflow);

e. to prevent spills, ensure that funnels are used when transferring liquids. (Frequent spills of small quantities quickly contaminate the environment and create unsafe working conditions);

f. regularly inspect all bulk containers for leaking valves, seeping bungs or caps. These inspections should be logged. Drip pans shall be utilized to catch small drips or spills;

g. ensure that all container storage areas are neat and organized such that containers will not be knocked over by personnel, wind or wave action;

h. ships are to ensure that new hazardous products are examined by a shipboard authority before they are allowed on board. This examination must include the possible non-hazardous alternatives, storage requirements and locations, and any special training requirements associated with the product;

i. hazardous materials are to be stored with due regard to compatibility. Hazardous Material General Storage Compatibility Charts are to be posted near HAZMAT storage areas to assist in identifying incompatible HAZMAT; and

j. take prompt steps to ensure the proper return and subsequent disposal of all hazardous waste.

k. Except in extreme circumstances, no hazardous waste shall be disposed of in foreign ports.

40. Although the directions above give details for the safe handling and storage of hazardous materials, as a general rule, all material should be handled in such a manner that personnel and equipment are not unduly exposed to any health or safety threat. In accordance with DND policy, WHMIS is applicable to all units. Reference F provides further guidance and direction regarding hazardous material policies and procedures for HMC Ships.

Air Emissions

41. MARCOM policies and guidelines governing air emissions during boiler soot blowing/smoke generation are contained in reference E. As a general rule, ships shall ensure that boilers, diesel engines, and gas turbines, are operated in such a manner as to minimize smoke emission.

Incineration

42. Hazardous material, including BIW, shall NOT be incinerated on board ships.

43. Every measure shall be taken to ensure correct and safe operation of shipboard incinerators. COs shall ensure that incinerators are properly fitted, maintained, and personnel are trained and take adequate personal safety precautions.

44. Incineration of combustible garbage may be used to reduce the volume of garbage that must be retained on board. Incinerators shall be operated as follows:

a. in general, any waste may be incinerated, with the exception of hazardous material and material which can be retained on board for recycling;

b. incineration residue (ash) shall be minimized through proper incinerator operation. Incinerators are to be "worked" to optimize their combustion efficiencies. Ash can be disposed of at sea beyond 12nm from the nearest coastline;

c. as an alternative, ash may be disposed of ashore. In this event, ash/remaining waste shall be thoroughly cooled, overhauled and securely bagged; and

d. Temporary incinerator operation is subject to the following additional restrictions:

(1) operation shall be specifically authorized by the ship's CO;

(2) such incinerators shall be correctly located on a ship's upper deck with adequate fire fighting equipment readily available;

(3) they shall be continually attended while in use; and

(4) they shall only be used during daylight hours and shall be controlled to minimize generation of smoke and visible flame.

PART III - FUELING

GENERAL

45. Every reasonable precaution shall be taken to prevent oil and hazardous substance spills, particularly during fueling or fuel transfer operations. Unnecessary discharges of oil and hazardous substances shall be avoided by developing correct operating procedures, and periodically checking for

proper functioning of equipment and systems.

46. Should a spill occur, the spread of the pollutant must be limited as soon as possible to reduce the potential for environmental damage. The necessary containment equipment shall be made available in the vicinity of potential incidents (e.g. on the jetty, near refueling sites, aboard ships, etc...)

47. Self-generated or observed pollution incidents at sea, in harbour or on land shall be reported in accordance with reference C and the directions from Formation HQs. MARCOM HQ N3, N4, N48 are to be informed of pollution incidents reported to the Formations.

48. Ships are required to use written fueling checklists in preparation for fueling. Completed checklists are to be retained on board for one year.

49. Following a spill, Formation Commanders may wish to consider ordering either an SI or TI in instances where such follow-on action is warranted.

Harbour

50. All MARCOM units and agencies shall make every effort to prevent, contain, and clean up oil and hazardous substance spills as directed in Formation orders.

51. Formations are to develop and promulgate ship class oil spill response plans which meet the intent of the *CSA*, as well as DND requirements. Ships are required to hold and keep current vessel-specific oil spill response plans based on the Formation supplied class plan.

52. To reduce the potential for, and impact of, an oil spill when fueling, the following procedures are to be effected:

a. in Halifax and Esquimalt Harbours ships shall normally embark fuel, except JP5, during normal working hours;

b. in Halifax and Esquimalt Harbours notice of intended fueling or de-fueling operations (including internal consolidation), shall be given in accordance with HCIs;

c. when fueling or consolidation takes place in darkness, ships sides are to be illuminated and sentries placed to give warning of overflow; and

d. a spill containment boom shall be placed around all vessels during fueling operations at DND berths. In submarines, the opportunity shall be taken to blow round while the boom remains in place.

Replenishment At Sea (RAS)

53. RAS operations are a potential source for oil pollution. It is estimated that a hose parting can release as much as 50 barrels of fuel even though pumps may be stopped and valves shut immediately.

54. RAS fueling operations will not normally be conducted within 12nm of a coast. Nevertheless, Ships' COs shall be cognizant of stricter restrictions on RAS by foreign coastal states (i.e. USN OPNAVINST 5090.1A - prohibits fueling operations within 50nm of a coast). All reasonable preventive measures shall be taken to minimize the potential for spills during the entire RAS evolution.

Additional Requirements For Ships Equipped With Water Compensated Fueling System (WCFS)

55. WCFS effluent shall not be discharged unless operational requirements necessitate. It is prohibited to discharge WCFS effluent if it does not meet the prescribed oil discharge levels.

56. Ships fitted with WCFS are required to take special precautions to prevent fuel discharge during refueling operations:

a. refueling at sea shall not be conducted within 12nm of land; and

b. in harbour, special arrangements shall be made to capture WCFS effluent and treat it as oily water. WCFS should not be released directly into the harbour; and

c. when WCFS ships are fueled, the discharged water shall be routed through a sullage barge, and/or a jetty treatment system where available.

ANNEX B

ENCLOSURE SYSTEM

1. The purpose of this Environmental Enclosure and Floor system is to ensure that no effluent or particles from the hydro blasting process escape into the harbour.

2. FMFCS has a requirement to construct a hull enclosure system for the HMCS Charlottetown. The approximate start date for this project will be May 9 and will extend to July 7.

3. The contractor must supply all labour and materials necessary to erect, dismantle, maintain and remove this enclosure system from the site.

4. The contractor is responsible for performing required maintenance on the enclosure within four (4) hours after being notified by the DND representative.

5. A mandatory site visit by the contractor is required prior to award of contract.

6. OPI is D. Randall, Phone #902 427-0550-2663.

STATEMENT OF REQUIREMENTS

Structure

1. The HMCS Charlottetown will be located on the Syncrolift platform at the Halifax Dockyard.

2. The Contractor is required to construct a temporary self-supporting structure around the perimeter of the hull.

3. The approximate dimensions of the Charlottetown enclosure are four hundred and twenty seven feet (427') long, extending past the syncrolift, by sixty-two feet (62') wide.

4. The contractor is to construct one (1) enclosure within the main enclosure approximately thirty two feet (32') by forty nine feet (49') as indicated on this drawing. Exact location to be indicated on site.

5. This structure must allow for a minimum working clearance of six feet (6') from the hull at a minimum height that extends to two feet (2') above the Boot Top (approximately 29 feet (29') above the syncrolift).

6. The structure must allow for:

a) one (1) brow stand at the stern,
b) one (1) large equipment access door at a size of twelve feet (12') high and eighteen feet (18') wide also located at the stern of the ship,

c) one equipment/personnel door at a size of six feet (6') wide and eight feet (8') high located at the stern on the port side, ten feet (10') from corner as indicated on drawing.

d) and two (2) additional personnel access doors of no less than three feet (3') wide and six feet eight inches (6'8") high as indicated on drawing.

These doors listed above must be rigid and fully retractable with a watertight seal.

Final locations for oil doors and brow stand are to be determined by site authority. Approximate locations are shown on drawing.

Enclosure

1. The enclosure must be capable of withstanding adverse weather conditions in the Halifax Harbour vicinity.

2. The enclosure shall be affixed to the hull to provide a weather tight seal without allowing the structure to exert force on the hull.

3. Ships blocking is to be made watertight using 8 MIL polyethylene.

4. The enclosure must be weather tight to allow inside temperature to be maintained by DND.

5. The material used to create the enclosure shall be translucent such that a sufficient amount of light will pass through to allow for work operations in the enclosure.

Floor Surface

1. The contractor shall supply/install and remove five eighths inch (5/8") G&T spruce standard (4' X 8') sheets of plywood to the deck of the syncrolift in a manner to eliminate cold and drafts from entering the enclosure. Joints in the plywood are to be sealed to make them watertight.

2. The contractor is to install a watertight curb around the perimeter of the plywood floor using four-inch (4") X four inch (4") spruce timber. This timber is to be sealed tight to the plywood as indicated in Typical Curb Detail shown on this drawing.



CONCLUSIONS

The Department of National Defense, Fleet Maintenance Facility on Cape Scott, in Halifax, NS has shown that it is possible to conduct large-scale complete refits and keep ourselves in business while protecting the environment. We have conducted five large-scale refits using the process that I have designed with complete success. We have also demonstrated repeatability with the capture system and utilized it through six cycles on the syncrolift. This has

served to reduce our operating costs when docking a ship thus, reducing the cost of the overall refit. I will continue to work on improving methods that will be more productive as the evolution of the process continues. It is important to note that all of the materials that were used in the design of the capture system have been sold to recyclers. It is important to note, that since we have used these capture systems on a large scale, we have not had one instance where we have had an environmental spill into the harbour.

Development, Demonstration and Validation of Zero Discharge Industrial Waste Water Treatment Plant (IWTP) At Puget Sound Naval Shipyard (PSNS), Bremerton, WA

Katherine Ford, NFESC, Walter Hunter, PSNS,
Ronald Bruening, IBC Advanced Technologies,
Todd Lloyd, Pro-Spec Engineering, Greg Levacun, NUWC Keyport,
Linda Weavers, Ohio State University, and
Hugo Destailats, California Institute of Technology

ABSTRACT

In FY94, the Office of Naval Research (ONR) tasked Naval Facilities Engineering Service Center (NFESC) to investigate emerging technologies for design of a zero discharge industrial wastewater treatment plant (IWTP) process. This IWTP RDT&E effort will enable Navy shipyards to treat wastewaters to the regulatory levels expected from the reauthorization of the Clean Water Act. The major influent Navy industrial wastestream to the IWTP is from shipyard metal finishing facilities. At PSNS, 90% of the wastewater volume is from (1) acid/alkali cleaning wastewaters, (2) chromium plating rinsewaters and (3) cyanide process wastewaters. Hydroxide precipitation is the conventional method for removal of heavy metals from these three wastestreams with the generation of hazardous sludge that must be sent to a landfill. Cyanide oxidation is by sodium or calcium hypochlorite prior to bulk precipitation. In addition to elimination of the sludge producing metals precipitation process, management of total toxic organics (TTO's) and biological vector control has to be considered. This paper will discuss the combinations of chemical, sorption/desorption, membrane processes, and advanced oxidation processes (AOP) that have been evaluated as modular components for designing a zero discharge IWTP, or to minimize point source discharges as found in Navy dry dock operations. Many of these

innovative wastewater treatment technologies are capable of dual use on shipboard at sea or while homeported. In FY94, an economic cost analysis was performed for potential treatment technologies for design of a zero discharge IWTP (Little, A.D., 1995).

Keywords: molecular recognition technology, zero discharge industrial wastewater treatment plant, hexavalent chromium, electrowinning, advanced oxidation processes, total toxic organics, anionic and nonionic surfactants, advanced reverse osmosis, ultrasonics, and sonolysis

INTRODUCTION

For the Navy as well as other DoD agencies, generation of these large volumes of industrial processing sludge will be restricted by Executive Order 12856 as stated in the Federal Compliance with Right to Know Laws and Pollution Prevention Requirements. In the next century, "the Federal Government should voluntarily set goals to reduce their agency's total releases of toxic chemicals to the environment and off-site transfers of such toxic chemicals by 50 percent by December 31, 1999, to the maximum extent practicable through source reduction". Heavy metal removal technology must enable DoD facilities to treat to the levels expected from the re-authorization of the Clean Water Act (CWA). Under CWA, DoD agencies will be required to meet the National Pollutant Discharge Elimination System (NPDES) and the General and Categorical Pretreatment Standards

under Section 307(b) and 307(c) of the CWA.

The ultimate goal of a zero discharge IWTP design is to recycle effluents and eliminate the generation of hazardous sludges. This zero discharge IWTP RDT&E program has been undertaken in five separate efforts: 1) metal recovery/recycle acid/alkali wastewaters, 2) recycle Cr (VI) from rinsewaters to process plating bath, 3) cyanide oxidation, and 4) destruction of total toxic organics. Surfactant destruction/deforming has been added since the ONR's inception of the zero discharge IWTP concept. Surfactants are increasing in volume in industrial wastewaters due to the change in parts cleaning processing from organic solvents, such as trichloroethylene (TEC) to alkaline cleaners. Lastly, metal monitoring technologies have been sought for IWTP processing operations. The use of an automated trace metal analyzer (ATMA) during testing of the MRT acid/alkali system will be discussed by Mike Putnam of SPAWARS SYS CEN, San Diego in these Proceedings.

Puget Sound Naval Shipyard's IWTP was chosen for pilot scale demonstration due to its large industrial operations which include several metal plating and cleaning operations, such as etching, passivating, plating, galvanizing and general cleaning. These processes generate rinse waters that must be treated by the IWTP before being discharged to the POTW, Bremerton, WA. The Shipyard (proper) encompasses 179 acres of land, 130 buildings, and seven permanent piers of deep water space. The shipyard has six dry docks, one of which is the largest in the U.S. Navy. The Naval Underwater Warfare Center (NUWC), Keyport, WA has also been selected to demonstrate advanced membrane technologies for cyanide process wastewaters. NUWC Keyport is involved in the first field studies for treatment of surfactant laden IWTP wastewaters. There is continuing coordination between PSNS and NUWC for exchanging information regarding emerging wastewater treatment technologies.

I. HEAVY METALS RECOVERY/ RECYCLE WITH SORPTION/ DESORPTION TECHNOLOGIES

Alternative methods to reduce sludge generation have been sought by changing the chemistry of the precipitation process. Sodium sulfide/ferrous sulfate (SS/FS) is a process for the reduction of hexavalent chromium (Cr VI) to trivalent chromium (Cr III), and precipitation of heavy metals such as cadmium, copper, lead, nickel, and zinc from industrial wastewaters. The SS/FS process results in a reduction in the quantity of sludge generated by 20 to 30% and has an annual cost saving of \$35,000 at NUWC Keyport (Durlak, 1997).

However, to avoid hazardous sludge altogether, a primary requirement of an alternative technology is that it be capable of removal of heavy metals ions such that they are selectively segregated from the wastestream in order to *recycle* to a process or *sell* to a reclaimer. An additional requirement is that the technology must remove the chromium below the current discharge standards in the *presence of other dissolved solids*. Besides heavy metal contamination, wastewaters often contain large concentrations of alkali metals (Na, K) and alkaline earth metals (Be, Mg, Ca,) which are not regulated. These metals do not need to be removed from the water before recycling, as would occur with conventional ion exchange technology.

NFESC investigated and reported the bench scale results of three novel metal adsorption technologies for sequential and selective heavy metal recovery in FY96 (Ford, K., 1996). In FY98, IBC Advanced Technologies was selected for pilot plant scale-up optimization studies leading to full-scale pilot demonstration at PSNS IWTP. IBC's ligand based adsorbent, patented as Superligs®, is a highly selective, non-ion-exchange process using organic ligands that are chemically bonded to solid supports such as silica gel (Bruening, R.I., 1991, Izatt, R.M., 1990). The metal selectivity is

achieved on carefully engineering the size and shape of the ligands (i.e., cavity dimensions, geometry, donor atom placement and type, and ring number and substituents as shown in Figure 1). Hence, the name for this technology is molecular recognition technology (MRT). Figure 1. illustrates one of these cavity-like, cyclic polyethers (crown ethers) that captures the metal ion, such as copper (Cu).

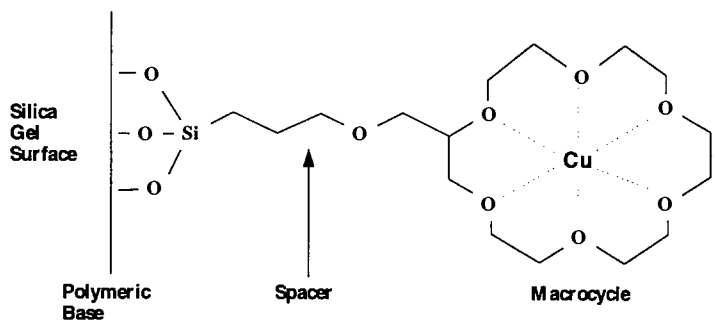

Figure 1. Schematic Showing Macrocycle Ligand, Spacer, and Solid Polymeric Base

In Figure 2, the *sequential* removal process is illustrated using IBC's patented macrocyclic ligands. This scheme shows the separation and elution conditions for Ag, Cu, Cr (III), and Cd by four columns from a representative Navy acid/alkali wastestream.

In FY98, the Environmental Security Technology Certification Program (ESTCP) funded a pilot scale demonstration at PSNS IWTP. Although the original intent of the ONR R&D was for sequential and selective removal of heavy metals for direct recycle, column design can be changed to meet Navy requirements. For example, Figure 3 shows that a MRT column can be designed for removal of only copper in the influent feed stream. Potentially this single metal removal design could be used for Navy ships dry dock operations where discharge limits are very stringent for copper.

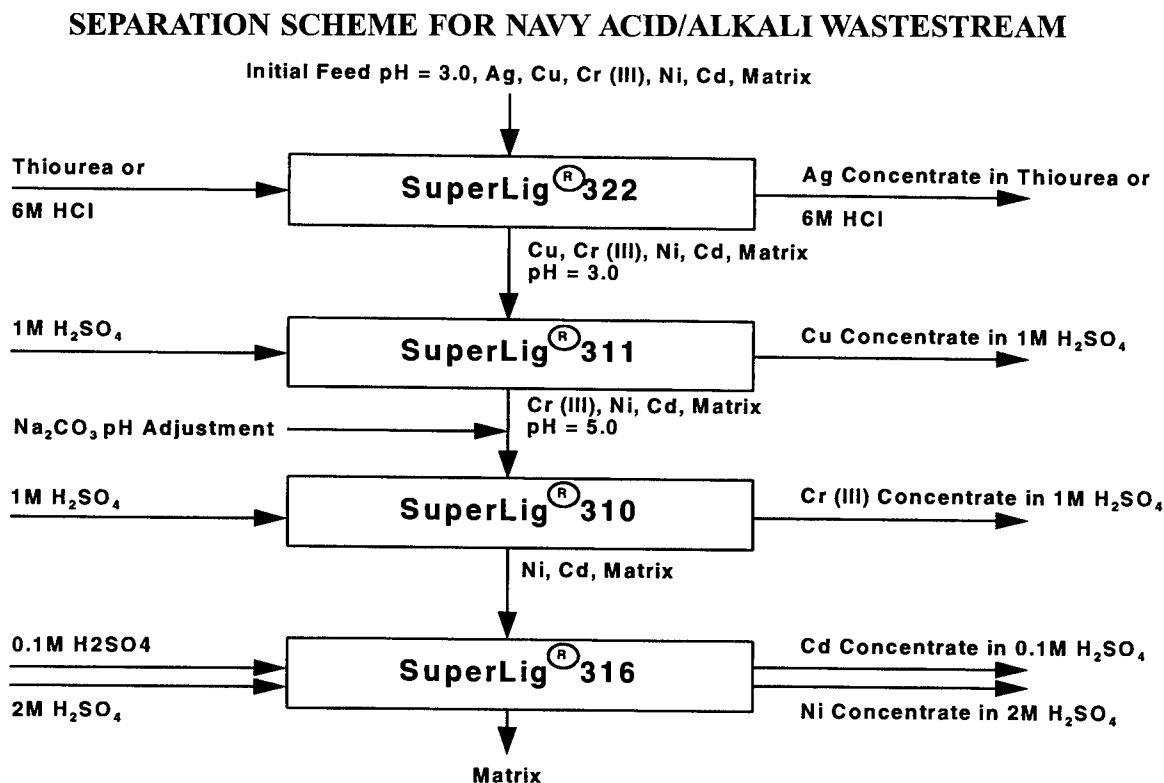

Figure 2. Column Separation Scheme for Removal and Concomitant Individual Separation of Ag, Cu, Cr (III), Ni, and Cd from Navy Acid/Alkali Wastewater

MRT Selective Removal of Copper

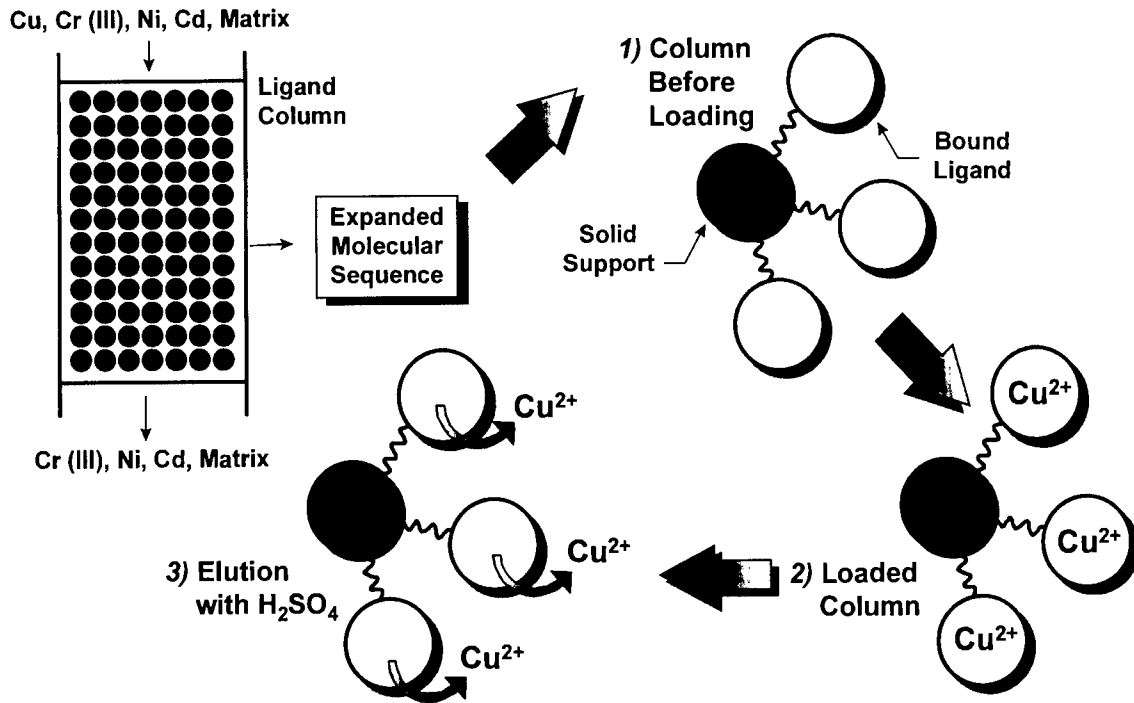

Figure 3. MRT Column Selective Removal/Recovery of Copper Ion.

MRT Acid/Alkali System with Addition of Chromium MRT System

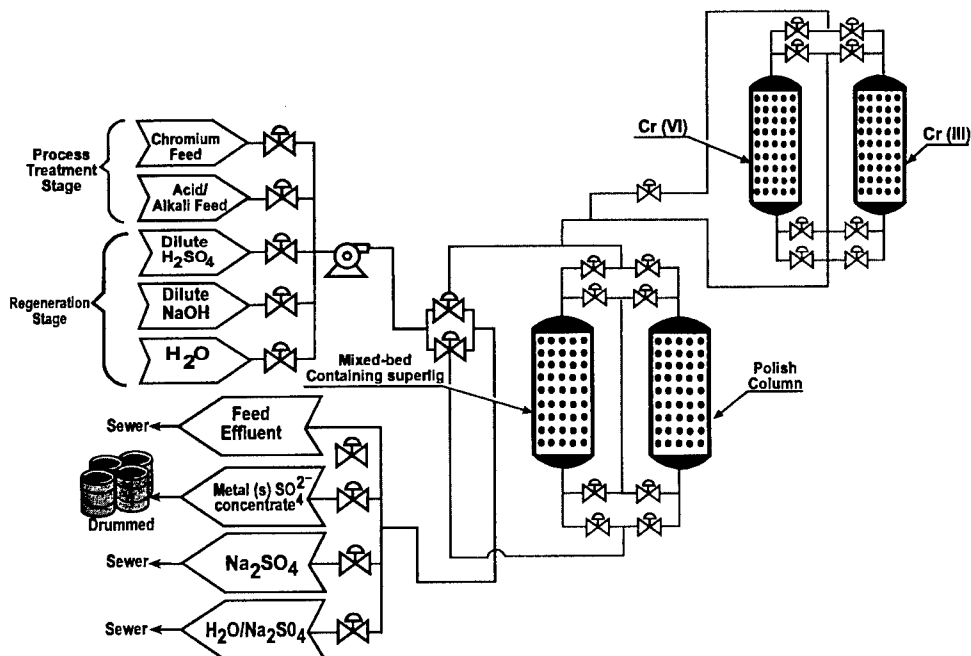

Figure 4. Schematic of PSNS Industrial Wastewater MRT System

Metal	Influent mg/l	Effluent Mg/l	Discharge Limit mg/l	% Extraction	Affinity Constnat
Mg	18.1	17.6	NA	2.5	0.02
Cd	0.7	0.005	0.17	99.4	13.8
Cr*	6.5	0.068	1.71	98.9	30
Cu	16.4	0.01	2.07	99.9	22
Ni	4.8	0.02	2.38	99.6	17
Pb	0.7	0.002	0.43	99.8	
Zn	9.4	0.099	1.48	98.9	14.4
Ag**	ND	NA	0.24	NA	13.8
Conditions: 1350 gals wastewater processed with flow rate 2 gal/min					
*Cr Discharge limits are for Total Chromium, Affinity Constant is for Cr (III)					
**Batch Did Not Contain Ag or Non-Detect					
*** Concentrations over 100% due to metals in sulfuric acid and PSNS water					

Table 1. MRT Operation Test Run One (1) for Acid/Alkali Wastestream

The industrial wastewater at PSNS IWTP contains only small quantities of precious metal silver. Therefore, a mixed Superlig bed column was favored over sequential and selective metal recovery as in Figure 2. Because chromium (VI) can be recycled back to the PSNS metal finishing facility, the wastewater will first be processed to remove Cr (VI) and Cr (III). See Figure 4. for the column design at PSNS's demonstration.

In FY99, the MRT system was installed for operational testing. . The preliminary results of this first operational testing are shown in Table 1. The analytical results show that magnesium (an alkaline earth metal) passed through the MRT column. The affinity constant being very low of 0.02. For all heavy metal the concentrations in the effluent stream were two orders of magnitude below PSNS monthly regulatory discharge limits for PSNS.

II. Chromium (VI) and (III) Treatment

MRT was equally successful in separating Cr (VI), Cr(III), Cu, and Ni into individual concentrates from a typical Navy chromium wastestream. It is significant to note that using MRT technology eliminates the conventional chemical reduction of Cr(VI) to Cr (III) prior to precipitation. During the acid/alkali MRT operational runs at PSNS, a Cr (VI) recovery system was not in place. The mixed bed column contained Superlig for Cr (III) recovery. Total chromium (Cr VI & III) for the pilot demonstration will be evaluated in FY00.

III. Cyanide Treatment Using Advanced Reverse Osmosis and Electrowinning

Cyanide wastewaters are primarily associated with electroplating shops located within the shipyard. The Navy generates in an excess of 550,000

gallons of cyanide wastewater annually. It is anticipated that the volume of cyanide based plating will decrease as other non-cyanide based coatings are developed (EPA 1994). Several cyanide treatment technologies have been evaluated using ion exchange (Little, 1993), reverse osmosis (Zapp, 1993) and electrowinning (Ford, 1994 & 1995). However, due to the high “throwing power” of the cyanide plating baths, the Navy will continue to use silver and gold cyanide plating baths, particularly for nuclear work. The conventional treatment process for cyanide is to oxidize the cyanide wastestream by alkaline chlorination. The cyanide is oxidized to cyanate, which is non-toxic.

An integrated advanced membrane treatment process for cyanide is shown in Figure 5.

This process consists of a combination of advanced reverse osmosis and electrowinning technology.

The cyanide wastewater is pumped to the advanced reverse osmosis (ARO) unit where the dissolved metal cyanides are concentrated prior to treatment by the electrolytic recovery unit (ERU). The permeate from the ARO is recycled back to the cyanide process. After positive results from field tests at Naval Air Station North Island metal finishing facility, a full scale demonstration is being tested at Naval Underwater Warfare Center, Keyport, WA. A report on the demonstration at Keyport will be released in FY00. Prior studies have shown higher ERU metal plating efficiency on a single metal rinsewater tanks (Ford 1994 & 1995) than that shown for bulk processing of 500 gallons at Keyport. There are on-going R&D

Cyanide: Advanced Reverse Osmosis Treatment System

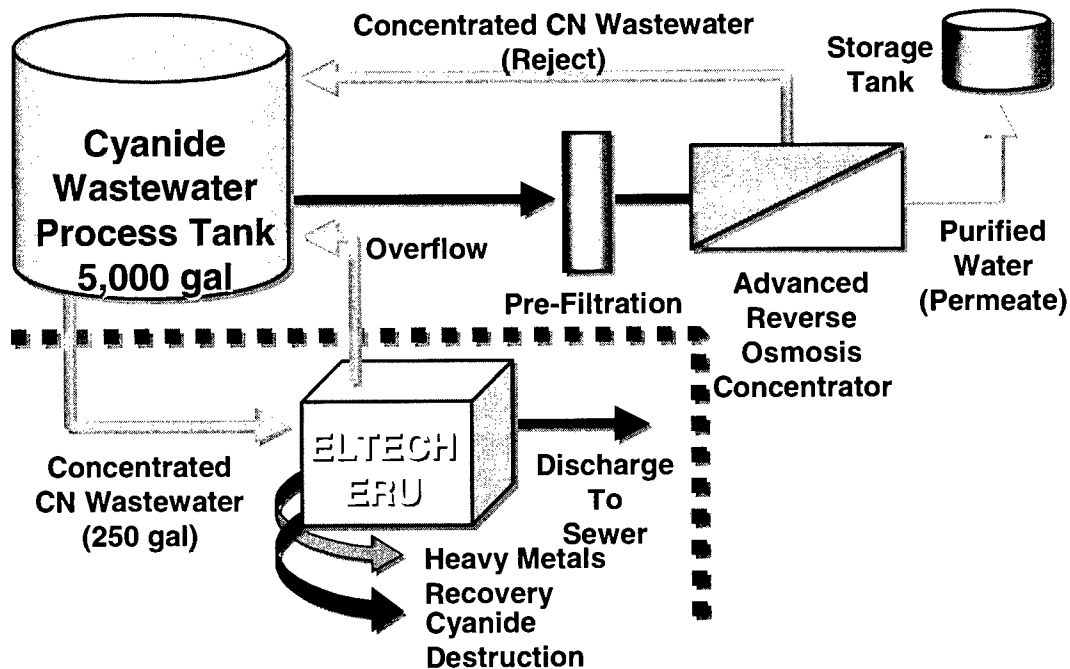

*Tom Kang, PI, NFESC, Code 421

Figure 5. Cyanide Advanced Reverse Osmosis/Electrowinning Treatment System

efforts, supported by ONR and Strategic Environmental Research Development Program (SERDP), for improvement of ERU design for metals recovery at the cathode and oxidizing capability at the anode (Weres, 1999)

IV. Advanced Oxidation Process for Total Toxic Organics (TTOs)

Navy activities generate industrial wastewaters containing toxic organic contaminants such as phenols, methylene chloride, and trichloroethane from various plating shop cleaning and paint stripping operations. Over 3,680,000 tons of wastewaters containing TTOs are treated annually by IWTPs at Navy locations. These plants are not specifically designed for the destruction of organics. They cannot consistently meet Federal discharge limits for total toxic organics (TTOs) which is determined by sum total of the concentrations of specific organic contaminants whose individual concentrations exceed 0.01 ppm. Some activities have added carbon adsorption for organics removal, resulting in costs of over \$10,000/month for disposal of the spent carbon. Effective and affordable treatment methods need to be developed for complete mineralization of toxic organics to meet existing requirements and the more stringent regulations that will be imposed by the impending amendment of the Clean Water Act.

It is possible to mineralize refractory organics down to very small levels using advanced oxidation processes (AOP) such as UV, UV/peroxide, and UV/ozone. However, obstacles to the effective utilization of these UV systems are 1) the relatively inefficient use of the solar spectrum and 2) the light delivery to a photocatalyst can be impeded by UV absorbing components in the waste stream. For these reasons, evaluation of *second generation* AOP reactors is being investigated. The free hydroxyl radicals are generated directly from the water, i.e., *in situ*, to oxidize organic contaminants. Thus, the reaction

does not require the use of chemical additions such as hydrogen peroxide. The equations below illustrate the differences between UV/peroxide and an emerging wastewater treatment technology such as sonolysis (ultrasonics).

Established AOP Treatment by Ultraviolet Irradiation

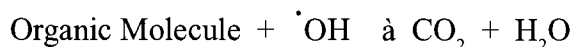

Emerging AOP *In-situ* Treatment by Ultrasonics

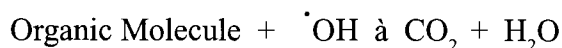
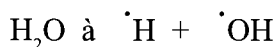

When ultrasonic-wave energy is transmitted in the water, destruction of organic compounds results from the formation of microbubbles. The microbubbles gradually grow with the ultrasonic frequency cycles until they attain a critical size, then collapse. As a result of this collapse, a large amount of energy and pressure is released. Water molecules under these conditions are decomposed to extremely reactive radicals. If organic compounds are present, they are directly destroyed. The final products of this process may be hydrogen, carbon dioxide, and/or some inorganic compounds (Suslick, 1989, Hoffmann, 1996, Hua, 1997, and Colussi, 1998). Over the last ten years, California Institute of Technology's Keck Laboratory has made significant advances in the application of ultrasonic irradiation to wastewater treatment. Model compounds, which mimic those found in Navy waste stream have been investigated (Kotronarou, 1991, 1992, and Hua, 1995, 1996). The effect of ozonolysis combined with sonolysis has also been extensively studied (Kang, 1998, Weavers, 1998). Recent investigation of the effects of frequency, temperature, hydrostatic pressure, and applied power have shown that optimization potential for the Navy's varied

requirements is possible. Keck Laboratory results indicate that high frequency ultrasound in the range of 400-600kHz is best suited for a wide range of wastewater applications. The induced chemical reaction rates have been found to be the highest in this frequency range. Another advantage of this frequency range is the absence of audible sound emissions. Since most readily available commercial sonication devices are limited to a frequency of 20 kHz, the equipment and facilities available in the Keck Laboratory for high frequency sonochemical application are unique.

NFESC is testing a high frequency ultrasonic reactor system at Keck Laboratories for mineralizing methylene chloride and phenols from the influent wastestream at Naval Air Station North Island, San Diego. In addition, wastewater samples from PSNS IWTP have been sent to Keck Laboratory for conformational studies. Keck Laboratory will perform detailed chemical analysis of the reaction intermediates and final reaction products generated during the ultrasonic irradiation experiments. The information is extremely important since it is essential to know if the target molecules are converted to other equally problematic products or if they are converted readily to innocuous products.

V. Treatment of Surfactant Laden Industrial Wastewaters

Many DoD activities are using aqueous immersion cleaning as a replacement for vapor degreasing solvents (Kodres, 1997). This usage is expected to increase with the restrictions on organic solvent cleaners, particularly those containing ozone depleting substances (ODS). UV irradiation treatment has been ineffective with these chelated metals due to the spectral interference of dissolved materials in the wastestream. At the Army's Lake City Army Ammunition Plant (LCAAP) the presence of chelated metals require increased polymer dosage prior to the bulk precipitation process. New surfactants and detergents are

created continuously to replace existing detergents and solvents in cleaning processes. These "improved" detergents are often more difficult to treat and result in fouling of wastewater treatment processes. For example, at the Naval Underwater Warfare Center in Keyport, WA, the use of a variety of non-ionic, and anionic surfactants results in failure of the chromium reduction and polymer flocculation processes. The EPA suggested solution of segregating waste streams before treatment does not work in this case because the chromium and surfactants are generated together. It is estimated that the lack of a treatment solution for this waste stream costs from \$30,000 to \$60,000 annually at Keyport alone. Other sites such as the Marine Corps Logistics Base in Barstow, CA have similar problems with surfactants. Therefore, methods to treat surfactants need to be developed.

A surfactant is a substance that adsorbs onto surfaces or interfaces and alters the interfacial free energy of the surface. Destruction of biodegradable surfactants typically occurs by biological treatment processes in wastewater treatment plants. However, biological treatment is often land intensive, expensive, and requires careful maintenance. Surfactant use is based on a variety of properties including foamability, chemical stability, solubility, reactivity, and corrosivity. For some applications it is not feasible to select a surfactant that is biodegradable, and it is possible that its toxicity properties are not well characterized or understood (Lewis, 1992). Ultrasonic irradiation of aqueous solutions has been shown to be effective for the *in situ* destruction of a variety of organic and inorganic contaminants (Francony and Pétrier, 1996; Hua and Hoffmann, 1996; Kontronarou, Mills et al., 1991; Kontronarou, Mills et al., 1992; Pétrier, Micolle et al., 1992). Ultrasonic irradiation produces cavitation bubbles which yield internal bubble temperatures on the order of 5000 K and pressures of hundreds of atmospheres upon their implosion (Leighton, 1994). The interior of a

cavitation bubble contains water vapor, gas and volatile compounds. Destruction of organic compounds occur in the cavitation bubble itself or at the interfacial sheath by direct pyrolysis or hydroxylation which results from the gas-phase pyrolysis of H₂O: $\text{H}_2\text{O} \rightarrow \text{H}\cdot + \text{OH}\cdot$

In addition, polymers such as long-chained-polymeric surfactants are subject to destruction by pressure and shear forces generated as the bubble collapses. Reactions are also possible in the bulk aqueous phase by oxidation with hydrogen peroxide which is formed in sonolytic systems from the self reaction of OH•, or the scavenging of H• by O₂ and the subsequent self reaction of HO₂•. Sonication has been shown to be particularly effective with volatile and hydrophobic compounds since they can partition to the bubble or interfacial sheath rapidly. Surfactants are expected to exhibit similar reactivities due to their tendency to accumulate at the bubble interface.

Sonoluminescence, a weak emission of light, also results from an acoustically cavitating bubble when high intensity ultrasound propagates through a liquid. Although sonoluminescence was first reported in 1934, the exact mechanism of the emission is still under debate. Lasting for less than 50 picoseconds, the light emission occurs in the final stages of bubble collapse when the contents of the bubble are under extreme temperature and pressure. A recent study has explored the role of surfactants and surface active agents on the intensity of sonoluminescence (Ashokkumar, Hall et al., 1997). They determined that the relative sonoluminescence intensity increased in the presence of an anionic surfactant, sodium dodecylsulfate (SDS), or a cationic surfactant, dodecyltrimethylammonium chloride (DTAC). Sonochemistry and sonoluminescence

are interrelated since violently collapsing bubbles generating high temperatures and pressures are required in both cases. Thus, increased sonoluminescence is expected to correlate with increased sonochemical activity. Also, the presence of a surfactant at a bubble surface has been shown to allow more rapid growth of a cavitation bubble by a process called rectified diffusion (Fyrillas and Szeri, 1995). This could result in a larger number of active cavitation bubbles and fewer bubbles that are growing to a radius where they will collapse violently. If bubbles are oscillating, but not cavitating, ultrasound is energetically inefficient. It is preferable to expend the ultrasonic energy to cause the cavitation bubbles to implode violently, and hence generate oxidizing free radicals.

The investigation at Ohio State University will determine the effectiveness of the sonochemical destruction of surfactants typically found in industrial wastewater treatment plants. For chemical experiments a near-field acoustical processor (NAP) with an ultrasonic irradiating area of approximately 1500 cm² will be used. The NAP will be temperature controlled by cooling the transducers. In addition, the reactor solution will be run in a continuous loop with a reservoir and pump in-line to monitor the ultrasonic reactions and reaction conditions as well as control the circulating flow rate. Real systems are very complex, therefore, it is often beneficial to investigate synthetic systems before the more complex matrix of a wastewater is explored. Ohio State University is currently studying the sonochemical reactions of a variety of nonionic, anionic, and cationic surfactants found in Keyport's influent wastewaters. These synthetic solutions will be based on realistic conditions in the industrial wastewater treatment plant.

GENERAL SUMMARY

Removal of trace heavy metals to well below detection limits, mineralization of refractory organics down to very low levels, and destruction of nonfilterable bacteria/viruses are possible in the dispersed/solution phase with a combination of state-of-art and newly emerging chemical processes. These processes would eliminate clarification problems, sludge drying and disposal, and variations in outflow quality. The effluent would meet industrial quality standards and be suitable for recycling.

ACKNOWLEDGEMENTS

The authors wish to thank the Office of Naval Research, Naval Facilities Engineering Command, and the Environmental Security Technology Certification Program for the financial support of the zero discharge IWTP. This support is gratefully acknowledged.

REFERENCES

Economic Analysis of Zero Discharge Industrial Wastewater Technologies

___Arthur D. Little, Inc. (1995) Economic Analysis of a Zero Discharge Industrial Wastewater Treatment Process, Contract Report CR 96-002 to the Naval Facilities Engineering Service Center, December 1995.

Heavy Metals Recovery/Recycle Using Sorption/Desorption Processes

___Durlak, Edward, (1997) User Data Package and Operation Test Report for the Implementation of the Sodium Sulfide/Ferrous Sulfate Process at Navy IWTPs, *USER Data Package UDP-2001-ENV*, Naval Facilities Engineering Service Center, Port Hueneme, CA 93043-4370.

___Ford, K. (1996) Heavy Metal Adsorption/Biosorption Studies for Zero Discharge Industrial Wastewater Treatment Plants” Technical Memorandum TM-2204-ENV, Naval Facilities Engineering Service Center, Port Hueneme, CA.

___R. I. Bruening, B.J. Tarbet, K.E. Krakowisk, M.I. Bruening, R. M. Izatt, and S. Bradshaw, (1991), Quantitation of Cation Binding by Silica Gel Bound Thianacrocyces and Design of Highly Selective Concentration and Purification Columns for Palladium (II), Gold (III), Silver (I) and Mercury (II), *Analytical Chemistry*, 63, 1014

___Izatt, R.M(R.L. Bruening, B.J. Tarbet, L.D. Giffin, M.L. Bruening, K.E. Krakowiak, and J.S. Bradshaw, (1990) Macrocycle-metal Cation Interactions Involving Polyaza Macrocyces Bonded to Silca Gel via a Nitrogen Donor Atom, *Pure and Applied Chemistry*, 63, 1115

Cyanide Wastewater Treatment Technologies

___Ford, K. and Koff, J., (1994), Operational Test Report for Testing and Evaluation of Electrolytic Recovery Unites at Naval Aviation Depot Cherry Point, Naval Air Warfare Center Indianapolis, and Norfolk Naval Shipyard, Technical Report, Naval Facilities Engineering Service Center, Port Hueneme, CA

___Ford, K, and Koff, J. (1995) User Data Package for Implementation of Electrolytic Recovery Technology in Navy Electroplating Shops, Technical Report TR-2046-ENV, Naval Facilities Engineering Service Center, Port Hueneme, CA 93043-4328.

___EPA, (1994) Guide to Cleaner Technologies, Alternative Metal Finishes, EPA/R-94/007 United States Environmental Protection Agency, Washington D.C. 20460.

___Authur D. Little, Inc. (1993) Test and Evaluation of a Pilot System for Ion Exchange Treatment of Cadmium Cyanide Wastes, *CR 93.007, NCEL* (now NFESC).

____Zapp, Karen, (1992) Removal of Cadmium and Chromium From a Pretreated Wastewater with Reverse Osmosis, Thesis, Master of Science Engineering, Purdue University.

____Weres, Oleh, SERDP In-Progress Review 1999, Electrochemical Advanced Oxidation Process (AOP) for Shipboard Final Purification of Filtered Black Water, Gray Water, and Bilge Water.

Advanced oxidation Process for TTO's Destruction

____Suslick, K. S. (1988) *Ultrasound: Its Chemical, Physical, and Biological Effects*. New York, VCH Publishers, Inc.

____M. R. Hoffmann, I. Hua, and R. Höchemer, (1996) "Application of Ultrasonic Irradiation for the Degradation of Chemical Contaminants in Water," *Ultrasonics Sonochemistry*, 3, S163-S172

____I. Hua and M. R. Hoffmann, (1998) "Optimization of Ultrasonic Irradiation as an Advanced Oxidation Technology," *Environ. Sci. Technol.*, 31, 2237-2243

____A. J. Colussi, L. K. Weavers and M. R. Hoffmann, (1998) "Chemical Bubble Dynamics and Quantitative Sonochemistry," *J. Phys. Chem. A.*, 102, 6927-6934 .

____A. Kotronarou, G. Mills and M. R. Hoffmann, (1991) "Ultrasonic Irradiation of p-nitrophenol in Aqueous Solutions," *J. Phys. Chem.*, 95, 3630-3638.

____A. Kotronarou and M. R. Hoffmann, (1992) "Decomposition of Parathion in Aqueous Solutions by Ultrasonic Irradiation," *Environ. Sci. Technol.*, 26, 1460-1462

____A. Kotronarou and M. R. Hoffmann, (1992) "Ultrasonic Irradiation of Hydrogen Sulfide in Aqueous Solutions," *Environ. Sci. Technol.*, 26, 2420-2428

____I. Hua, R. H. Höchemer and M. R. Hoffmann, (1995) "The Sonolytic Hydrolysis of p-nitrophenylacetate: The Role of Supercritical Water," *J. Phys. Chem.* 99, 2335-2342.

____I. Hua and M. R. Hoffmann, (1996) "The Kinetics and Mechanism of the Sonolytic Degradation of CCl₄ in Aqueous Solution: Reaction intermediates and By-products," *Environ. Sci. Technol.*, 30, 864-871

____I. Hua, R. H. Höchemer and M. R. Hoffmann, (1995) "The Sonochemical Degradation of p-nitrophenol in a Parallel-Plate Near-field Acoustical Processor," *Environ. Sci. Technol.*, 29, 2790-2796

____J. W. Kang and M. R. Hoffmann, (1998) "The Kinetics and Mechanism of the Sonolytic Destruction of Methyl Tertiary Butyl Ether (MTBE) by Ultrasonic Irradiation in the Presence of Ozone," *Environ. Sci. Technol.*, 32, 3194-3199

____L. K. Weavers, F. H. Ling, and M. R. Hoffmann, (1998) "The Combination of Sonolysis and Ozonolysis for Aromatic Compound Degradation," *Environ. Sci. Technol.*, 32, 2727-2733

____L. K. Weavers and M. R. Hoffmann, (1998) "The Sonolytic Decomposition of Ozone in Aqueous Solution: Mass Transfer Effects," *Environ. Sci. Technol.*, 32, 3941-3947

____H. M. Hung and M. R. Hoffmann, (1999) "Kinetics and Mechanism of the Sonochemical Degradation of Chlorinated Hydrocarbons: Frequency Effects," *J. Phys. Chem.*, in press

____H. M. Hung and M. R. Hoffmann, (1999) "Effects of Frequency, Hydrostatic Pressure, Temperature and Applied Power on Sonochemical Reactions," *J. Phys. Chem.*, in review

____J. W. Kang, H. M. Hung, A. Lin and M. R. Hoffmann, (1999) "The Sonolytic Destruction of Methyl Tertiary Butyl Ether (MTBE) by Ultrasonic Irradiation: Effects of Ozone and Frequency," *Environ. Sci. Technol.*, in press

____H. M. Hung, F. H. Ling and M. R. Hoffmann, (1999) "Kinetics and Mechanism of the Enhanced Reductive Degradation of Nitrobenzene by Elemental Iron in the Presence of Ultrasound," *Environ. Sci. Technol.*, in review

____H. M. Hung and M. R. Hoffmann, (1998) "Kinetics and Mechanism of the Enhanced Sonochemical Degradation of CCl_4 in the Presence of Elemental Iron," *Environ. Sci. Technol.*, 32, 3011-3016

Treatment of Surfactant Laden Industrial Wastewaters

____Kodres, C.A., Polly, D. R. Hoffard, T. A., and Anguiano, G.D. (1997) Surface Quality Impact of Replacing Vapor Degreasers with Aqueous Immersion Systems, *Technical Report TR-2067-ENV*, Naval Facilities Engineering Service Center, Port Hueneme, CA 93043-4370.

____Ashokkumar, M., R. Hall, P. Mulvaney, and F. Grieser. (1997). Sonoluminescence from Aqueous Alcohol and Surfactant Solutions. *J. Phys. Chem.* 101, 10845.

____Brennen, C. E. (1995) *Cavitation and Bubble Dynamics*. New York, Oxford University Press.

____Francony, A. and C. Pétrier. (1996) Sonochemical Degradation of Carbon Tetrachloride in Aqueous Solutions at Two Frequencies: 20 kHz and 500 kHz. *Ultrasonics Sonochemistry*. 3, S77.

____Fyrillas, M. M. and A. J. Szeri. (1995) Dissolution or Growth of Soluble Spherical Oscillating Bubbles: The Effect of Surfactants. *J. Fluid Mech.* 289, 295.

____Hammit, F. G. (1980) *Cavitation and Multiphase Flow Phenomena*. New York, McGraw-Hill.

____Hua, I. and M. R. Hoffmann. (1996) Kinetics and Mechanism of the Sonolytic Degradation of CCl_4 : Intermediates and By-Products. *Environ. Sci. Technol.* 30, 864.

____Kontronarou, A., G. Mills and M. R. Hoffmann. (1991) Ultrasonic Irradiation of p-Nitrophenol in Aqueous Solution. *J. Phys. Chem.* 95, 3630.

____Kontronarou, A., G. Mills and M. R. Hoffmann. (1992) Oxidation of Hydrogen Sulfide in Aqueous Solution by Ultrasonic Irradiation. *Environ. Sci. Technol.* 26, 2420.

____Leighton, T. G. (1994) *The Acoustic Bubble*. London, Academic Press.

____Lewis, M. A. (1992) The Effects of Mixtures and Other Environmental Modifying Factors on the Toxicities of Surfactants to Freshwater and Marine Life. *Wat. Res.* 26, 1013.

____Petrier, C., M. Micolle, G. Merlin, J. L. Luche and G. Reverdy. (1992) Characteristics of Pentachlorophenolate Degradation in Aqueous Solution by Means of Ultrasound. *Environ. Sci. Technol.* 26, 1639.

____Suslick, K. S. (1988) *Ultrasound: Its Chemical, Physical, and Biological Effects*. New York, VCH Publishers, Inc.

Contamination of Butyl- and Phenyltin Compounds in Sediment from Shipyards in Korea

Won Joon Shim¹, Jae Ryoung Oh², Nam Sook Kim³ and Soo Hyung Lee⁴

Chemical Oceanography Division,
Korea Ocean Research and Development Institute,
Ansan PO Box 29, Seoul 425-600, Korea

ABSTRACT

Butyl- and phenyltin compounds were quantitatively determined in surface sediments and sediment cores from near shipyards. Tributyltin (TBT) and triphenyltin (TPT) concentrations reached up to 46100 and 308 ng Sn/g on dry weight basis at the front of shipyard, respectively. Horizontal distribution of butyltin compounds was closely related with harbors and shipyards. Butyltin and phenyltin concentrations were relatively low where remote from the sources. Vertical distribution of organotins in sediment showed active use of them in Korean peninsula for past decades. The half-lives of organotins in a year scale provides a concern on persistence of these compounds in marine environment.

Keywords: Tributyltin, triphenyltin, shipyard, sediment, half-life

INTRODUCTION

Organotin compounds are among the most widely used organometallic chemicals. Production of organotins has increased for various purposes since their first biocidal application in the early 1920s (Thompson *et al.*, 1985). One of the major applications lies in heat stabilization for synthetic polymers and another lies in their use as agricultural biocide (WHO, 1980). Tributyltin (TBT) used as biocidal additive for antifouling paints has received much attention since its adverse effects on oyster farms near marina were revealed in the early 1980s (Alzieu, 1986). A series of studies have showed that TBT is highly toxic toward various non-target marine organisms (for review see Fent, 1996). Starting in the 1980s, many industrialized countries have regulated the use of TBT in antifouling paints. There is no regulation on application of TBT based antifouling to ship hulls and releasing of waste water

¹ Chemical Oceanography Division, Korea Ocean Research and Development Institute (KORDI), Ansan, PO Box29, Seoul 425-600

Korea, Tel: +82-345-400-6169, Fax: +82-345-406-4250, E-Mail : wjshim@kordi.re.kr (Won Joon Shim)

² Chemical Oceanography Division, Korea Ocean Research and Development Institute (KORDI), Ansan, PO Box29, Seoul 425-600

Korea, Tel: +82-345-400-6169, Fax: +82-345-406-4250, E-Mail : wjshim@kordi.re.kr (Won Joon Shim)

³ Chemical Oceanography Division, Korea Ocean Research and Development Institute (KORDI), Ansan, PO Box29, Seoul 425-600

Korea, Tel: +82-345-400-6169, Fax: +82-345-406-4250, E-Mail : wjshim@kordi.re.kr (Won Joon Shim)

⁴ Chemical Oceanography Division, Korea Ocean Research and Development Institute (KORDI), Ansan, PO Box29, Seoul 425-600

Korea, Tel: +82-345-400-6169, Fax: +82-345-406-4250, E-Mail : wjshim@kordi.re.kr (Won Joon Shim)

containing TBT from shipyard in Korea yet. Furthermore, organotin contamination even in high potential area like shipyard has not been yet well documented.

Tributyltin is mainly introduced to marine environment through leaching from antifouling paint applied on ship hulls. Municipal wastewater may also partially account for input (Chau *et al.*, 1992). It is difficult to identify the sources and pathways of TBT with a limited monitoring study due to its complex behavior in marine environment. In most studies, the contamination of TBT has usually been monitored at only a few selected points (*e.g.* Tolosa *et al.*, 1992). The samplings were frequently concentrated near harbors, which has very little ecological significance. Extensive survey data of TBT covering a whole basin are seldom available. Limited sampling density has often made it difficult to evaluate how far TBT contamination has spread from the source areas.

Vertical distribution of chemicals in sediment cores provides the history of contamination. Not only the trend of organotin contaminant for past several decades but also half-lives of organotin can be inferred from the vertical distribution. The half-life of TBT in seawater was known to be from days to weeks, while that in sediment exceeded several months in laboratory study (Adelman *et al.*, 1990). The half-life of TBT estimated from the sediment core samples was longer than several years (de Mora *et al.*, 1989). However, the half-life of triphenyltin (TPT) has not been estimated with field samples. Although use of TBT was banned from the early 1980s, TBT has still been detected from the marine sediments (Quevauviller *et al.*, 1994). Desorption from the sediment associated organotin is regarded as one of possible TBT input sources. In ecotoxicological concern, trend of organotin contamination and their extent of persistency in the marine ecosystem are important.

In the present study, butyl- and phenyltin compounds in surface sediments and sediment cores were quantitatively determined to study horizontal and vertical distribution of these compounds. Surface sediments were more extensively studied in major shipyards in Korea to reveal sources and pathways of organotins. Organotins in sediment core were analyzed to investigate the trend of past organotin contamination in Korea and to estimate the half-lives of TBT and TPT in sediments.

MATERIALS AND METHODS

Study Area

Ten surface sediment samples were collected from Ulsan Bay in 1996, where two large harbors and a repairing shipyard is located (Fig. 1). Five sediment samples were collected from Okpo Bay in 1996, where one of largest shipyard in Korea is located (Fig. 2). Sediment cores were also taken from St. 5 in Ulsan and St. 3 in Okpo Bay in 1998.

Sample Collection

Surface sediment samples were collected, using a van Veen grab. Approximately the top 2 cm of sediments were taken by a stainless steel spoon and stored in acid-washed polycarbonate jar. The collected samples were immediately frozen with dry ice and transferred to laboratory for analysis

Sediment core samples were taken with SCUBA diving using an acryl barrel (length 50 cm, internal diameter 12 cm). The tubes were manually sunk into the sediment to obtain 20-40 cm long cores depending on the site. The core was sectioned in 2 cm interval with stainless plates. Only the central part was sampled to avoid possible contamination from the corer. Collected samples were frozen and later freeze-dried. Depth of sediment core was counted from the surface.

Analytical Procedure

The analytical procedure used on the sediment sample is a modification of the method suggested by Stallard *et al.* (1989). Air-dried sediments were ground and weighed to about 5 g in 50 mL polypropylene centrifuge tubes. Triphenyltin chloride was added to samples as a surrogate recovery standard. The samples were digested with 10 ml of 6 N HCl and subsequently extracted with 20 ml methylene chloride by shaking for 3 h. After 10 min centrifugation (4000 rpm), 2 ml of organic extracts were transferred to 15 ml glass test tubes and concentrated to about 25 ml under a gentle stream of nitrogen. Then the samples were resuspended in 2 ml *n*-hexane and derivatized with 250 μ l of 2 M hexylmagnesium bromide for 20 min. The remaining Grignard Reagent was neutralized with 4 ml of 0.4 N sulfuric acid. The organic phase was recovered by centrifugation and cleaned up on 2 g of activated florisil. During the clean-up, the organotin compounds were eluted with *n*-hexane. The cleaned extracts were concentrated again and spiked with tetrabutyltin as an internal standard, and then analyzed by gas chromatograph (Hewlett Packard 5890 Series II) equipped with a capillary column (SPB-1, 30 m x 0.25 mm i.d. x 0.25 μ m film thickness) and a flame photometric detector. A filter with a range from 625 to 2000 nm (Dietrich Optical) was mounted on the flame photometric detector. Under splitless injection mode, 2 μ l of sample were injected. The gas chromatograph operating condition and quality assurance and quality control of the procedure were reported elsewhere (Shim *et al.*, 1999). Concentration of organotin compounds is expressed as ng/g of Sn on a dry weight basis to allow direct comparisons of the organotin compounds.

RESULTS

Occurrence of butyl- and phenyltins in surface sediment

Butyltin compounds were detected from all sites surveyed. TBT, dibutyltin (DBT), and monobutyltin (MBT) concentrations ranged 26 - 13300, <1 - 5090 and <2 - 1390 ng/g, respectively. The highest TBT, DBT and MBT concentrations were found in front of repairing shipyard in Ulsan Bay (St. 5 in Fig. 3), at which total butyltin concentration (sum of TBT, DBT and MBT concentrations) reached up to 19780 ng/g. The concentration of TBT accounted for the largest portion (69%) of total butyltin composition, and it was followed with DBT (20%) and MBT (11%).

Phenyltin compounds were detected at the only 11 out of 15 sites. TPT, diphenyltin (DPT) and monophenyltin (MPT) ranged <5 - 308, <4 - 103 and <3 - 339 ng/g, respectively. Mean total butylltin concentration (4313 \pm 6347 ng/g) was 33 times higher than that of total phenyltin (98 \pm 191 ng/g). Mean percent composition of each phenyltins was 33% for TPT, 15% for DPT and 50% for MPT.

Horizontal distribution of butyl- and phenyltins in surface sediment

Horizontal distribution of BTs in Ulsan Bay was quite different from the other harbors surveyed in this study, because exceptionally elevated TBT, DBT, and MBT concentration was found at St. 5 in front of the largest repairing shipyard in Korea (Fig. 3). Even though TBT concentrations at Sts. 1 through 6 exceeded 600 ng/g and began to decrease from St. 6 toward outer stations, positive

TBT gradient shown from Sts. 1 through 5. Relatively high concentrations were found at St. 2 (938 ng/g) and St. 3 (1030 ng/g) compared to St. 1 (649 ng/g) and St. 4 (984 ng/g) at which harbors are located, respectively. Mean TBT percent composition in Ulsan Bay was 67%. Phenyltin compounds were detected from 8 out of 10 stations in Ulsan Bay. All the highest TPT, DPT and MPT concentration were detected at St. 5 same as BTs (Fig. 4). Horizontal distribution of TPT was similar to TBT in Ulsan Bay. TPT concentration showed negative gradients from St. 5 to St. 1 as well as from St. 5 to outer stations. Although three PTs were detected at Sts. 4, 5, and 6, the only high MPT (213 ng/g) concentration was found at St. 1.

Inside of breakwater in Okpo Bay, 11700 and 9190 ng/g of TBT were detected at Sts. 1 and 3, respectively, close to dry-docks of the shipyard (Fig. 5). These TBT concentrations were the second and the third highest among the 15 stations in this study. All of those exceptionally high TBT concentrations were found near shipyard. St. 4 also had 4300 ng/g of high TBT concentrations, whereas 1210 ng/g was found at St. 1. DBT and MBT concentrations were also relatively high at Sts. 1, 3 and 4. High mean TBT percent composition (74%) at five stations indicated that TBT compound has been freshly input in this area. Phenyltin compounds were also detected from Sts. 1, 3 and 4 (Fig. 6). TPT concentrations were 40 ng/g at Sts. 1 and 3, respectively. Distribution of total concentrations of PTs at the three stations showed similar trend to that of BTs.

Vertical distribution of butyl- and phenyltins in sediment core

TBT concentration of the core from St. 5 (UL) in Ulsan Bay exceeded 5000 ng/g at all depth (Fig. 7a). Exceptionally elevated TBT concentration (46100 ng/g) was found at the surface of UL and thereafter the concentration decreased markedly with depth.

A core was sampled in front of a shipyard in Okpo Bay (OP). Elevated TBT concentration of about 9000 ng/g was detected near surface and it was steeply decreased to a depth of 38-40 cm (Fig. 7b). Three butyltin concentrations were in order of TBT > DBT > MBT. Percent TBT composition was higher than 60% from the surface to a depth of 20-22 cm.

While TBT concentration in 2 cores showed decreasing profiles from surface to a certain depth, the decreasing trend in TPT was seen in a core from Okpo Bay (Fig 8b). The TPT profile of UL was quite different from that of TBT (Fig. 8a). A subsurface maximum was found at a depth of 12-14 cm in UL. The only OP showed a near surface maxima of TPT concentration and then the concentration decreased with increasing core depth (Fig. 8b).

Half-life of tributyltin and triphenyltin in sediment

Half-life of TBT and TPT in sediment was estimated from profile of these compounds in undisturbed cores and sedimentation rate. Model assumptions were that the sediment and organotin fluxes were constant and that the only loss mechanism for organotin was via degradation *in situ*. Acknowledging that the greatest source of uncertainty is the sedimentation rate, this simple model can be utilized to calculate the degradation rate in 2 cores for TBT and a core for TPT.

Sedimentation rates were estimated based on ²¹⁰Pb activity profiles. Table 1 lists statistical information, together with the estimated degradation rates and half-lives. The half-lives for TBT in UL and OP were 9.9 and 2.6 years, respectively. The half-life of TPT in OP was 3.1 yr.

RESULTS AND DISCUSSION

Shipyards are thought to be primary sources of TBT and TPT in the coastal environment of Korea as in other coastal areas (*e.g.*, Tolosa *et al.*, 1992; Yonezawa *et al.*, 1993). Overall TBT concentrations in sediments are comparable to those in Portuguese coastal environments (1–520 ng Sn/g) (Cortez *et al.*, 1993). Page *et al.* (1996) reported the similar range of TBT concentration (24–2760 ng TBT/g) in sediments from South Portland, Maine, U.S.A. TBT concentrations ranged from <1.5 to 1300 ng Sn/g except a ship repair area (3300±390 ng Sn/g) of Puget Sound (Krone *et al.*, 1989). Tolosa *et al.* (1992) also reported maximum TBT concentration near dry-dock harbor up to 9260 ng/g and at the other sites, the concentrations ranged up to 2420 ng/g in western Mediterranean coast. In this study, exceptionally higher TBT concentrations were found at the sites near shipyard. These results support that dry-docking activity is one of major sources of TBT compound.

When the number or tonnage of ships arrived each harbor was compared, the contribution of shipyard on TBT contamination was much higher. Ships arrived in Okpo Bay was 3,059,647 in tonnage and 951 in number in 1997 (MOMAF, 1997). However, TBT in sediment from Okpo Bay was 4 times higher than that of Pusan Harbor (MOMAF, 1998) in which 205,216,729 tons of and 33,557 of ships were arrived in the same period. Both the bay and harbor were almost blocked with breakwaters. These results support the significant input of TBT from shipyard during new application or removal of antifouling paints on or from ships.

Despite the well-known toxicity and the significantly long half-life of TPT in the marine environment (Fent, 1996), as well as the existence of analytical procedures for its determination in aquatic matrices, its occurrence in marine sediment has been reported by only Tolosa *et al.* (1992) and Gomez-Ariza *et al.* (1998). Phenyltins

were not detected in seawater and TPT was detected up to 11 ng/g from the Huelva coast, Spain (Gomez-Ariza *et al.*, 1998). Although Tolosa *et al.* (1992) also reported low TPT concentrations compared to that of TBT in western Mediterranean coastal enclosures, TPT was detected up to more than 200 ng/L in seawater and 4000 ng/g in sediment at several sites near marina. In this study, TPT was detected up to 308 ng/g in surface sediment and up to 4390 ng/g in sediment core, which are comparable to those mentioned above. Significant correlation between TBT and TPT concentrations in surface sediments and sediment cores where TPT was detected indicates that antifouling paint contribute to source of TPT compound in the marine environment. However, horizontal and vertical distribution of TPT in sediment is not as clear as that of TBT. Therefore, further study is required to identify TPT sources other than antifouling paint and to evaluate factors affecting its distribution.

The risk to the environment from TBT and TPT use is a function of both the toxicity of the chemical and its persistence and behavior in the environment. When a chemical is subjected to rapid degradation, calculation of its risk to the environment is especially sensitive to factors other than toxicity. Previous work indicates that TBT is fairly rapidly degraded in marine waters. Half-life of TBT in seawater is from several days (Seligman *et al.*, 1988) to several months (Maguire and Tkacz, 1985). However, as TBT shows a tendency to accumulate in sediments, TBT degradation processes in sediments are more likely to control the overall persistence of TBT in the environment. It becomes increasingly apparent from various recent studies that the degradation of TBT in sediments is a very slow process (Maguire and Tkacz, 1985; Fent and Hunn, 1991) with half-lives in the range of years (de Mora *et al.*, 1989; Watanabe *et al.*, 1995). The half-lives of TBT (2.6 and 9.9 yr) and TPT (3.1 yr) estimated from sediment core profile in this study are more or less higher than those of estimated from

laboratory experiment (0.3 – 2.2 yr) (Watanabe *et al.*, 1995) and from core profile (2.6 yr) (de Mora *et al.*, 1995). However, no data is available to compare degradation and half-life of TBT in sediment.

The microbial degradation of TBT and the biochemical pathways involved are poorly understood, and thus investigations into the degradation of TBT in sediment should be carried out in more detail, under both aerobic and anaerobic conditions. Preliminary data from laboratory experiment indicated that the degradation in anaerobic sediment layers was much slower than under aerobic conditions (Yonezawa *et al.*, 1994). Page *et al.* (1996) reported that elutriating study of sediment from shipyard resulted in elevated TBT concentrations in seawater over water quality standard (2 ng/L) (Waite *et al.*, 1991). Therefore, desorption of TBT from contaminated sediment (Watanabe *et al.*, 1995), enhanced TBT concentration in surface sediment and cores, and considerable persistency of TBT in anaerobic sediment could be a concern on efficiency of regulation on use of TBT based anti-fouling paint.

REFERENCES

- Alzieu, C. (1986) TBT detrimental effects on oyster culture in France - evolution since antifouling paint regulation. In: Proceedings of the Oceans '86 International Organotin Symposium, vol.4. pp. 1130-1134.
- Adelman, D., Hinha, K. R. and Pilson, M. E. Q. (1990) Biogeochemistry of butyltins in an enclosed marine ecosystem. *Environ. Sci. Technol.* 24: 1027-1032.
- Chau, Y. K., Zhang, S. and Maguire, R. J. (1992) Determination of butyltin species in sewage and sludge by gas chromatography-atomic absorption spectrometry. *Analyst*, 117:1161-1164.
- Cortez, L., Quevauviller, Ph. and Donard, O. F. X. (1993) Survey of butyltin contamination in Portuguese coastal environments. *Environ. Pollut.* 82:57-62.
- Fent, K. and Hunn, J. (1991) Phenyltins in water, sediment, and biota of freshwater marinas. *Environ. Sci. Technol.* 25: 956-963.
- Fent K. (1996) Ecotoxicology of organotin compounds. *Crit. Rev. Toxicol.* 26:1-117.
- Gomez-Ariza, J. L., Morales, E. and Giraldez, I. (1998) Spatial distribution of butyltin and phenyltin compounds on the Huelva coast (Southwest Spain). *Chemosphere.* 37(5): 937-950.
- Krone, C. A., Brown, D. W., Burrows, D. G., Chan, S. and Varanasi, U. (1989) Butyltins in sediment from marinas and waterways in Puget Sound, Washington State, USA. *Mar. Pollut. Bull.* 20(10): 528-531
- Maguire, R. J. and Tkacz, R. J. (1985) Degradation of the tri-n-butyltin species in water and sediment from Toronto Harbor. *J. Agric. Food Chem.* 33: 947-953.
- Ministry of Maritime Affairs and Fisheries (MOMAF) (1997) Annual statistics of fisheries and maritime. MOFMA, Seoul, Korea pp. 620 (in Korean).
- Ministry of Maritime Affairs and Fisheries (MOMAF) (1998) Technical Report: Studies on TBT contamination in marine environment of Korea (in Korean).
- de Mora, S. J., King, N. G., and Miller, M. C. (1989) Tributyltin and total tin in marine sediments: profiles and the apparent rate of TBT degradation. *Environ. Technol. Lett.* 10: 901-908.

- de Mora, S. J., Stewart, C. and Phillips, D. (1995) Sources and rate of degradation of tri(n-butyl)tin in marine sediments near Auckland, New Zealand. *Mar. Pollut. Bull.* 30(1): 50-57.
- Page DS, Ozbal CC, Lanphear ME, (1996) Concentrations of butyltin species in sediments associated with shipyard activity. *Environ. Pollut.* 91(2):237-243
- Quevauviller, Ph., Donard, O. F. X. and Etcheber, H. E. (1994) Butyltin distribution in a sediment core from Arcachon Harbor (France). *Environ. Pollut.* 84: 89-92.
- Seligman, P. F., Valkirs, A. O., Stang, P. M. and Lee, R. F. (1988) Evidence for rapid degradation of tributyltin in a marina. *Mar. Pollut. Bull.* 531-534.
- Shim, W. J., Oh, J. R., Kahng, S. H., Shim, J. H. and Lee, S. H. (1999) Horizontal distribution of butyltins in surface sediments from an enclosed bay system, Korea. *Environ. Pollut.* 106: 351-357.
- Stallard, M. O., Cola, S. Y. and Dooley, C. A. (1989) Optimization of butyltin measurements for seawater, tissue, and marine sediment samples. *Appl. Organomet. Chem.*, 3: 105-114.
- Thompson, J. A., Sheffer, M. G., Pierce, R. C., Chau, Y. K., Cooney, J. J., Cullen, W. P. and Maguire, R. J. (1985) Organotin compounds in the aquatic environment: Scientific criteria for assessing their effects on environmental quality. National Research Council Canada, Ottawa, Canada, pp 284.
- Tolosa I, Merlini L, de Bertrand N, Bayona JM, Albaiges J (1992) Occurrence and fate of tributyl- and triphenyltin compounds in western Mediterranean coastal enclosures. *Environ. Toxicol. Chem.* 11:145-155.
- Waite, M. E., Waldock, M. J., Thain, J. E., Smith, D. J. and Milton, S. M. (1991) Reduction in TBT concentrations in UK estuaries following legislation in 1986 and 1987. *Mar. Environ. Res.* 32: 89-111.
- Watanabe, N., Saki, S. -I. and Takatsuki, H. (1995) Release and degradation half-lives of tributyltin in sediment. *Chemosphere.* 31(3): 2809-2816.
- WHO (1990) Tributyltin compounds, World Health Organization, Geneva, pp. 273.
- Yonezawa Y, Nakata K, Miyakozawa Y, Ochi A, Kowata T, Fukawa H, Sato Y, Masunaga S, Urushigawa Y (1993) Distribution of butyltins in the surface sediment of Ise Bay, Japan. *Environ. Toxicol. Chem.* 12:1175-1184.
- Yonezawa, Y., Fukui, M., Yoshida, T., Ochi, A., Tanaka, T., Noguti, Y., Kowata, T., Sato, Y., Masunaga, S. and Urushigawa, Y. (1994) Degradation of tri-n-butyltin in Ise Bay sediment. *Chemosphere* 29(6): 1349-1356.

Table 1. Statistical parameters, sedimentation rate, degradation rate and half-life of TBT and TPT in sediment.

Core	N	Sedimentation rate (cm/yr)	k (yr ⁻¹)	T _{1/2} (yr)	r ²
Tributyltin					
UL	9	0.58	-0.060	9.9	0.90
OP	16	1.07	-0.266	2.6	0.98
Triphenyltin					
OP	9	1.07	-0.221	3.1	0.74

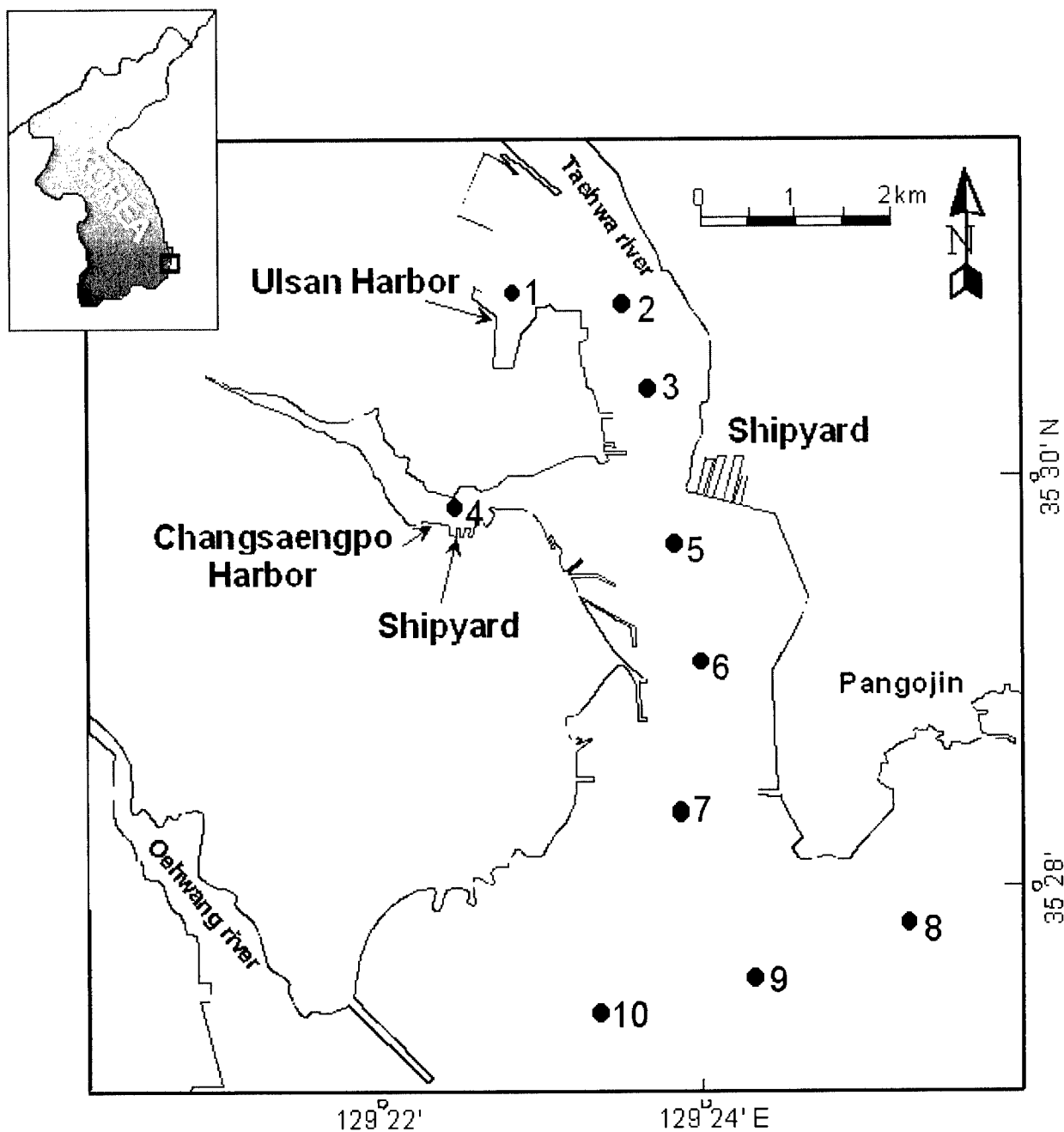

Fig. 1. Location of sediment sampling stations in Ulsan Bay

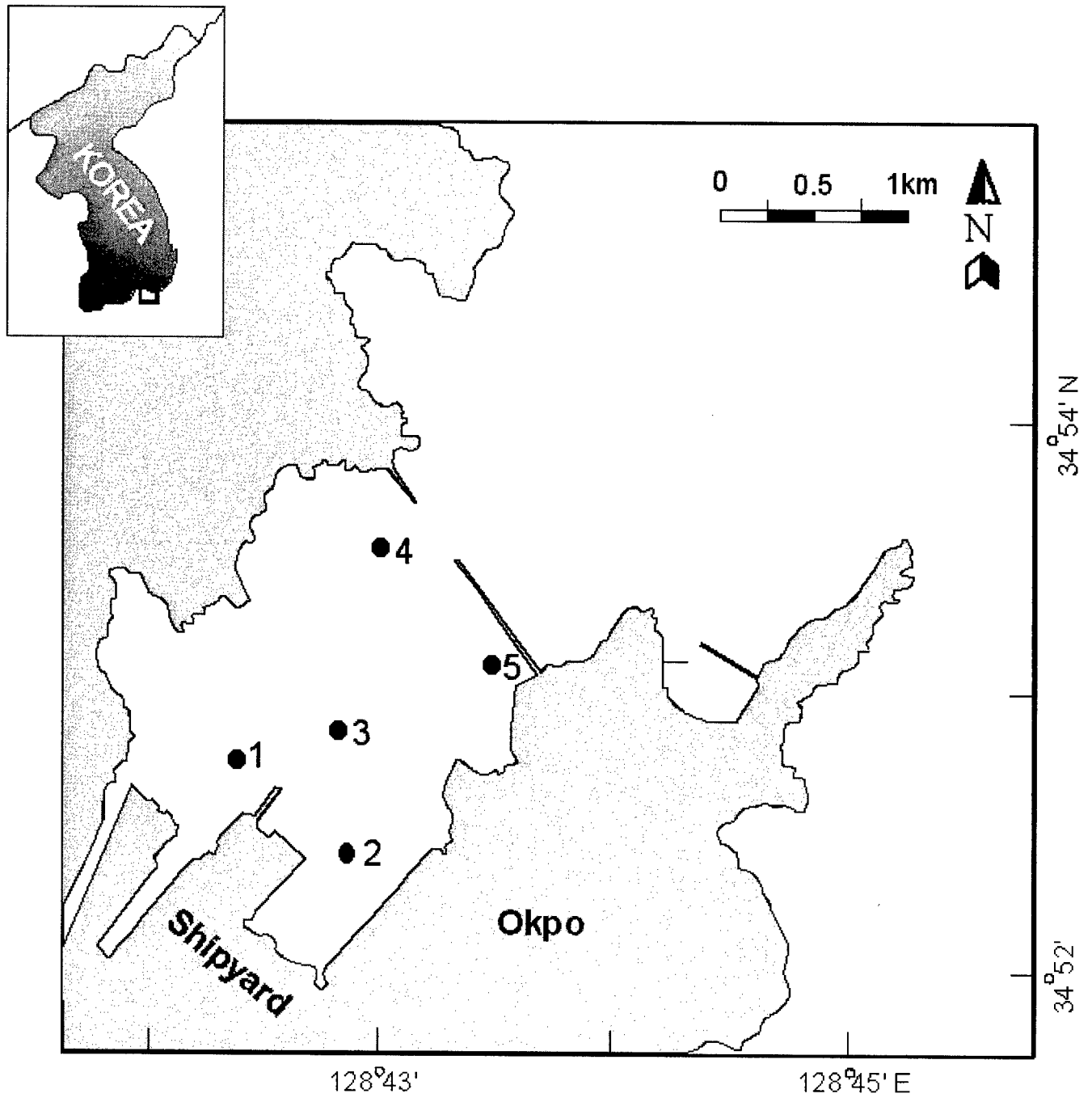

Fig. 2. Location of sediment sampling stations in Okpo Bay

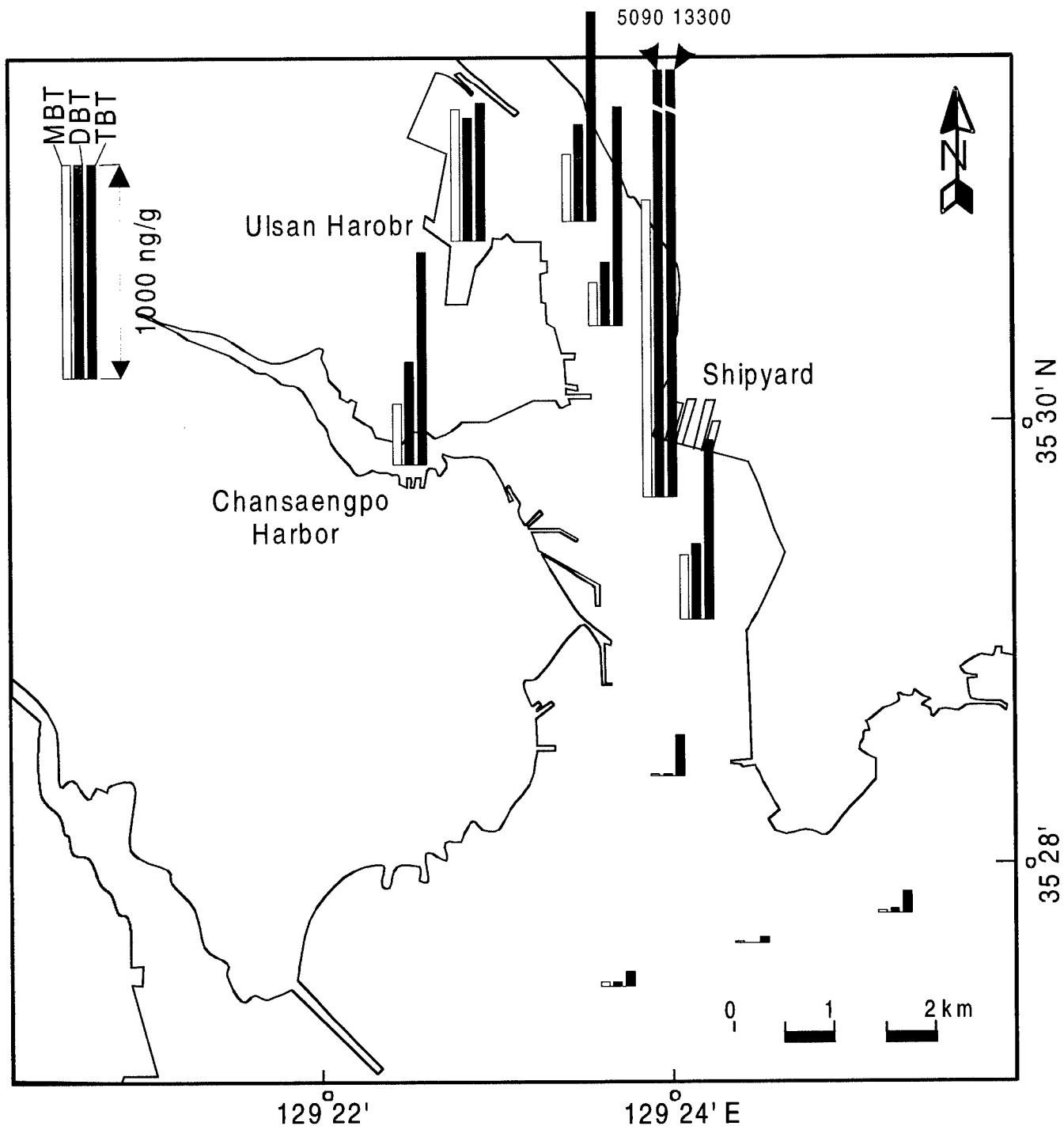

Fig. 3. Butyltin concentrations in surface sediment from Ulsan Bay

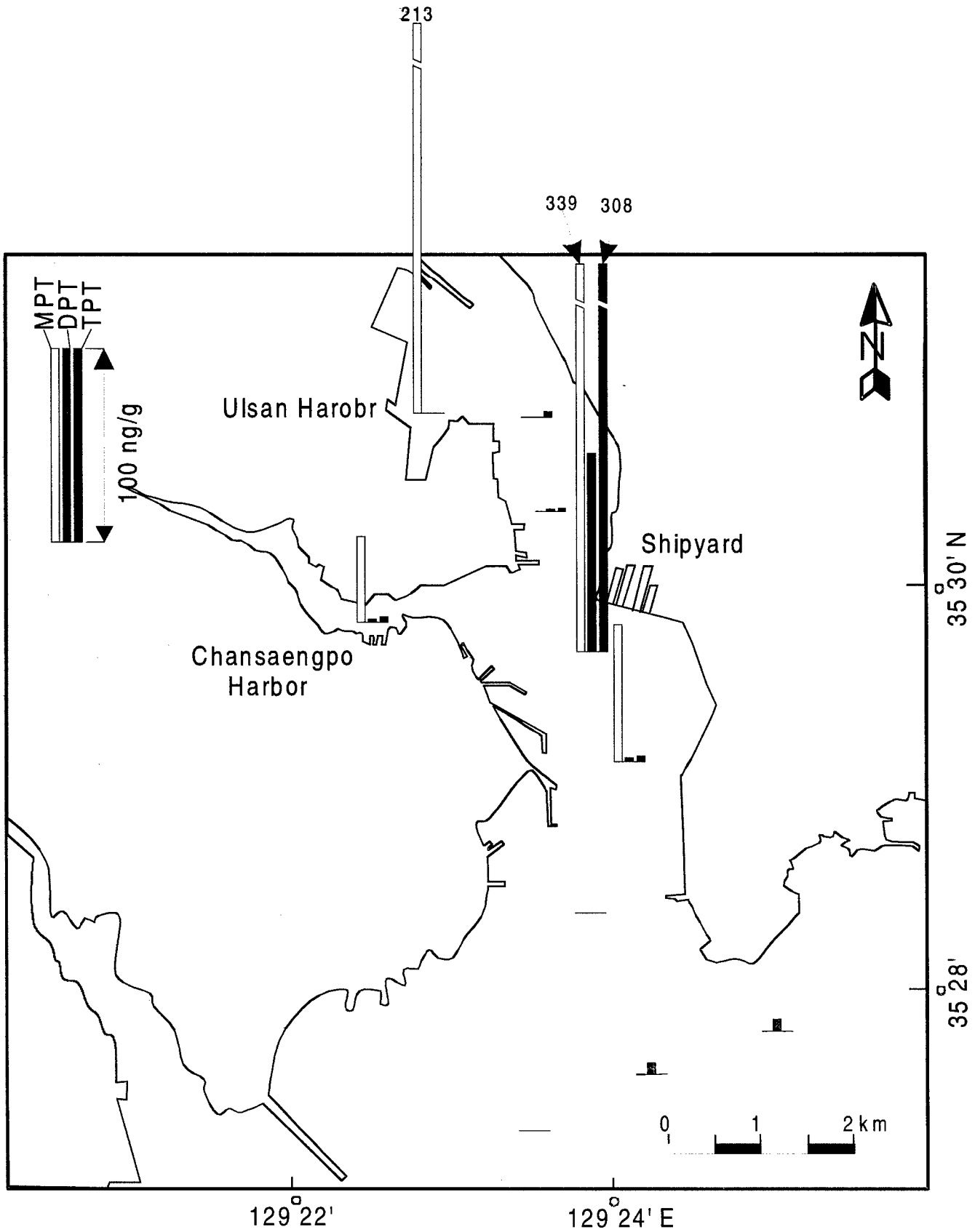

Fig. 4. Phenyltin concentrations in surface sediment from Ulsan Bay

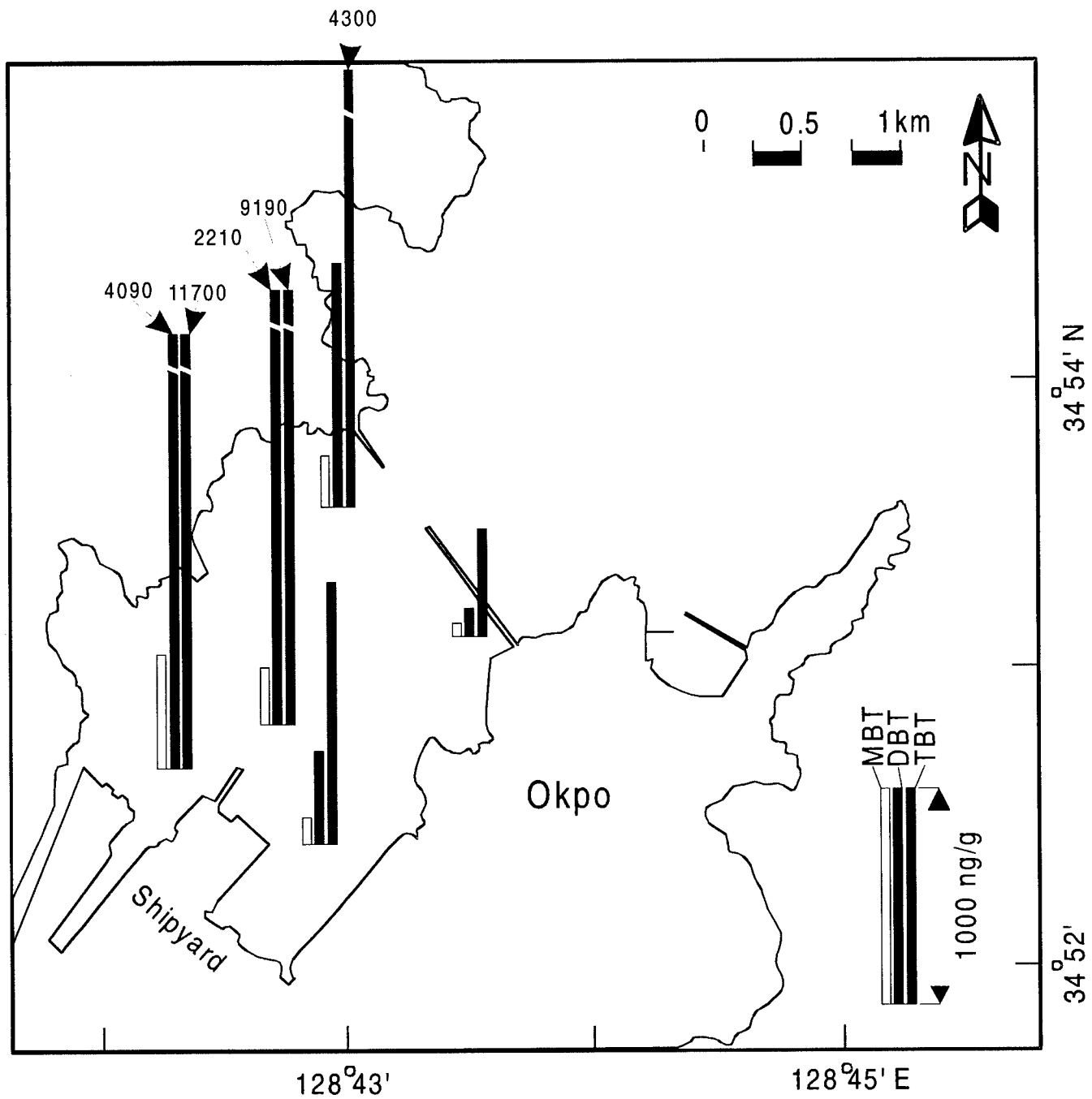

Fig. 5. Butyltin concentrations in surface sediment from Okpo Bay

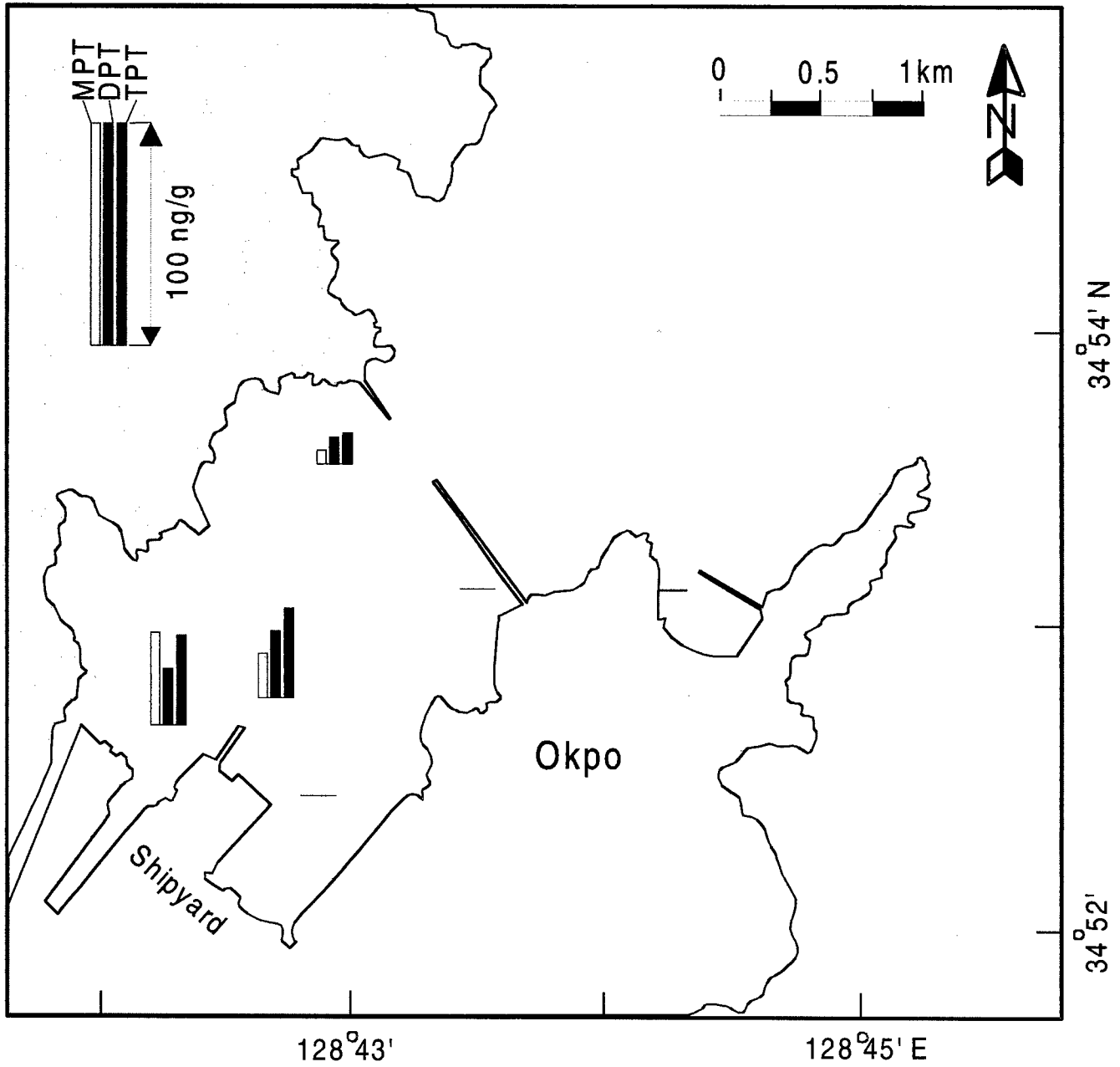

Fig. 6. Phenyltin concentrations in surface sediment from Okpo Bay

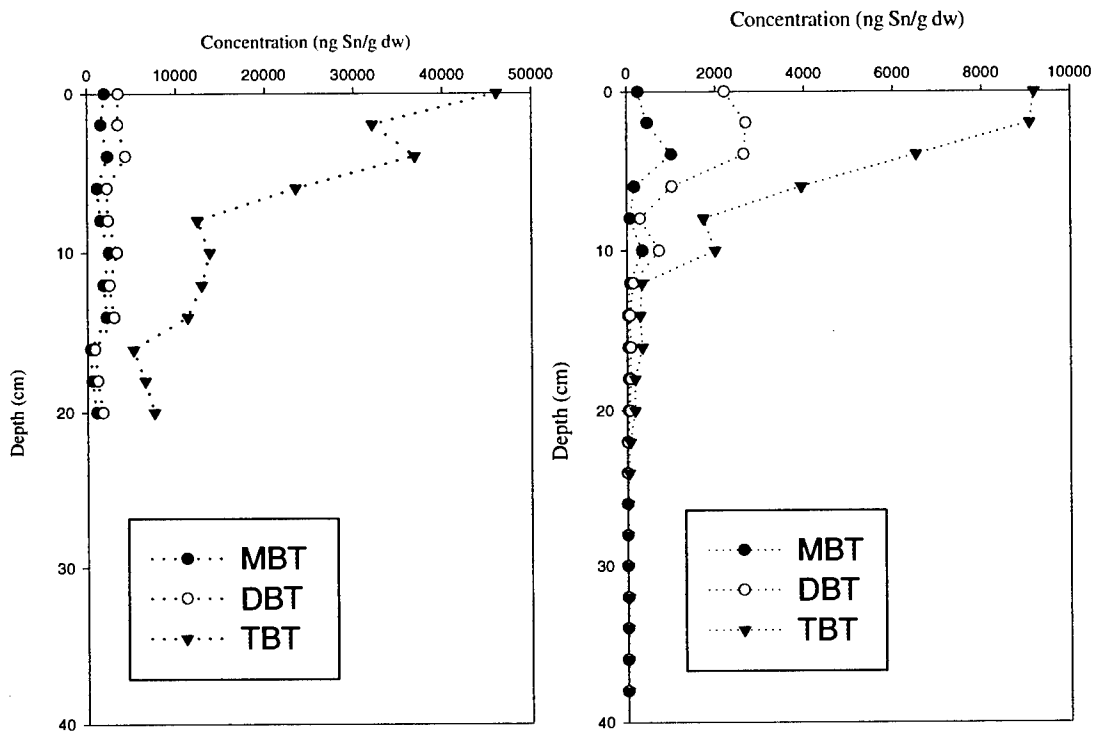

Fig. 7. Butyltin concentration profiles in cores from Ulsan Bay (a) and Okpo Bay (b)

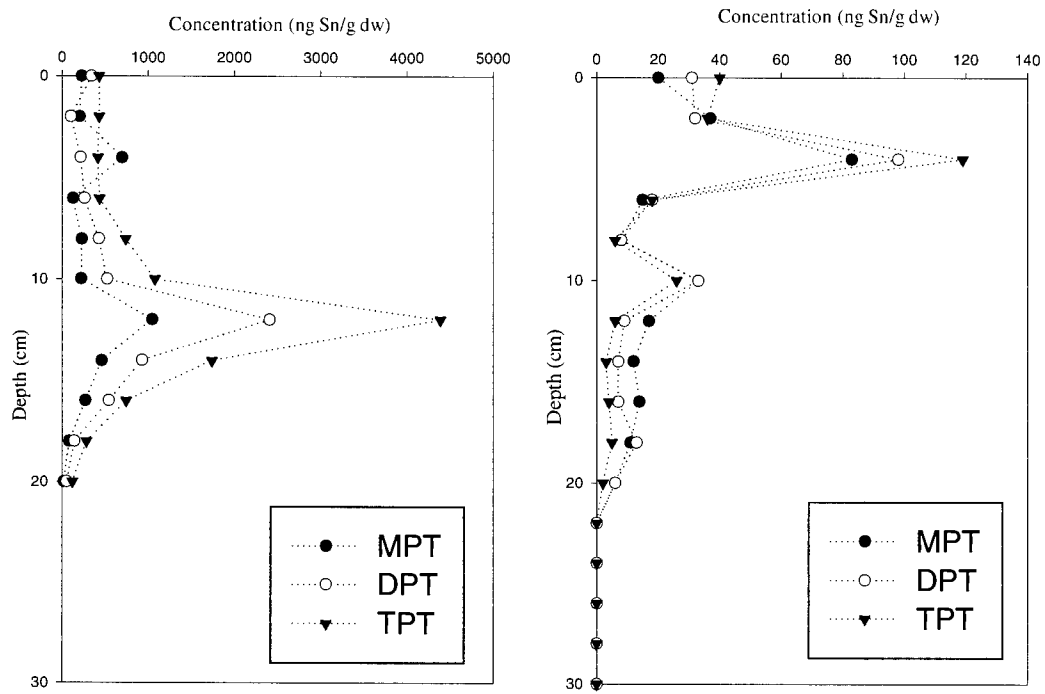

Fig. 8. Phenyltin concentration profiles in cores from Ulsan Bay (a) and Okpo Bay (b).

Overview of Stormwater General Sector Permits for Shipyards: A Federal Perspective

Joel H. Salter Jr.¹

ABSTRACT

An overview of the U.S. Environmental Protection Agency (US EPA) National Pollutant Discharge Elimination Program and NPDES Discharge Permits from a Federal perspective. For an extensive discussion or the EPSA NPDES Permit Program and NPDES Discharge Permits, see the EPA home page at <http://www.epa.gov.owm>. Here you will find general information and links to specific information. It is even possible to obtain copies of the storm water general sector permit for shipyards from the Federal Register online.

Keywords: Storm Water, Discharges, Shipyards, Drydocks, EPA, National Pollutant Discharge Elimination Program and NPDES Discharge Permits.

INTRODUCTION

Under the Clean Water Act Section 402 Congress has appointed to the Administrator of the EPA the authority to implement a permit program designed to reduce if not eliminate the discharge of harmful pollutants into waters of the US.

What is NPDES?

This program is the National Pollutant Discharge Elimination Program (NPDES). It requires that all point source dischargers apply for a permit to discharge.

- You are required to have a permit if you have a discharge of pollutant via a man made conveyance to a water of the US; and
- The discharger must obtain a permit from EPA or an approved State permit program. Currently 44 of the 50 states are authorized to administer their own "State" permit programs.

What is a Permit?

- It is a license;
- Issued by the government to persons conducting business in the U.S;
- Granting permission to do something which would be illegal in the absence of the permit;
- There is no right to a permit and it is revocable for cause (noncompliance); and
- Therefore an NPDES permit is a license to discharge and is renewed every five years.

The Scope of the NPDES Permit Program?

- There are Municipal permits and Non-municipal permits; and
- Shipyards are issued primarily Non-municipal discharge permits.

¹ Environmental Scientist, Office of Wastewater Management, NPDES Permits Division, 401 M St. SW, Mail Code 4203, Washington DC, 20460, Tel (202)-260-4847, Fax (202) 260-XXXX, E-Mail: salter.joel@epa.gov (Joel Salter)

Types of Discharge and Associated Regulations

Process Waste Water:

- 40 Code of Federal Regulations (CFR) 122
- 40 CFR 125
- 40 CFR 405-499

Non-Process Wastewater:

- 40 CFR 122
- 40 CFR 125

Storm Water -Storm Water Program:

- 40 CFR 122
- 40 CFR 125

There is also a General Storm water permit developed for Shipyards, published in the Federal Register (FR) Vol. 60. No. 186, Friday September 29, 1995, Notices Q and R.

Q) Storm Water Discharges Associated with industrial activity from water transportation facilities that have vehicle maintenance shops and/or equipment cleaning operations.

R) Storm Water Discharges Associated with industrial activity from ship and boat building or repair yards.

An Overview of the Science and Regulation of TBT and the Potential for Future Liability for Contaminated Harbor Sediments

Michael A. Champ

Advanced Technology Research Project (ATRP) Corporation

P.O. Box 2439, Falls Church, Virginia 22042-3934, USA

Tel (703) 237-0505, Fax (703) 241-1278, E-Mail: <machamp@aol.com>

ABSTRACT

A draft Assembly Resolution prepared by the Marine Environmental Protection Committee (MEPC) of the International Maritime Organization (IMO) to propose a global ban on the use of organotins in antifouling paints was approved by the IMO Assembly at its 21st Regular Session (November 1999). In approving the Resolution, the Assembly agreed that a legally binding instrument (global convention – an international treaty) be developed by the Marine Environment Protection Committee that should ensure by January 1, 2003 a ban on the application of Tributyltin (TBT) based antifouling paints and January 1, 2008 as the last date for having TBT-based antifouling paint on a vessel. The Assembly also agreed that a Diplomatic Conference be held in 2001 to consider the adoption of the international legal instrument. Monitoring, policing, enforcement, fines and record keeping are yet to be defined. In addition, the MEPC has also proposed that IMO promote the use of environmentally safe anti-fouling technologies to replace TBT.

In the U.S., existing coastal zone, federal and state regulations have had a significant impact on reducing TBT levels, generally to well below the provisional water quality standard of 10 ng/L, and in bivalve tissues. Current environmental and marine and estuarine water concentrations are well below predicted acute TBT toxicity levels. Estimation of chronic toxicity effects using mean water TBT concentrations indicate that current levels would be protective of 95% of species. Analysis of allowable Daily Intake/Oral Reference Dose Values from market basket surveys and the NOAA National Status and Trends data suggest that

there is no significant human health risk from consuming seafood contaminated with TBT. Most of the data that exceeded these values were from areas of high TBT input from ports, harbors and marinas (commercial shipping, shipyards and drydock facilities) and sites of previous contamination. In the U.S., at this time, TBT environmental data and lack of acceptable alternatives does not justify a global ban for TBT.

This papers presents a discussion of: (1) Global environmental TBT concentrations and exceptions, (2) Comments on the scientific basis for the regulation of TBT, (3) The TBT scientific controversy, (4) Antifouling biocides and invasive species, and (5) The potential liability to shipping industry, shipyards and paint manufactures from the global ban on TBT in antifouling paints.

Keywords: Tributyltin, TBT, biofouling, antifouling marine coating, regulation, policy, toxicity, invasive organisms, liability and contamination of dredged materials.

GLOBAL ENVIRONMENTAL CONCENTRATIONS A DECADE AFTER REGULATION

In the United States, since the passage of the Antifouling Paint Control Act of 1988, the environmental concentrations of organotin compounds have declined (Seligman et al., 1990; Wade et al., 1991; U.S. EPA, 1991; Valkirs et al., 1991 and Huggett et al., 1992). Three national and regional monitoring programs in the U.S. have sampled for TBT since the passage of OAPCA in 1988. These are the U.S. National Oceanic & Atmospheric Administration's (NOAA) National Status and Trends Monitoring

(NS&T) Program, which was created in 1984 (see O'Connor, 1998). Overviews are presented in the Proceedings of the Coastal Zone 93 and the special issue of MPB Vol. 37 No. 1 (O'Connor and Pearce, 1998) and the papers there in. A second TBT monitoring program was the U.S. Navy Long-term Monitoring Program associated with Navy home ports and harbors (See U.S. Navy, and EPA, 1997). The third monitoring program is the consortium of tributyltin manufactures (ORTEPA) Long-term Monitoring Program contracted to Parametrix Inc., with results published in Cardwell et al., (1997; 1999); ORTEPA (1997, 1998). The results of these three national monitoring programs have been compared by Russell et al. (1998) who found that all of these programs have found declining environmental concentrations of TBT over time since the enactment of OAPCA in 1988. Water concentrations have declined 56% - 71%, sediment 47% -55% decline, and bivalve tissues 40%-82% within a few years. Mean TBT concentrations in water are generally below the current U.S. EPA marine chronic water quality criterion of 10 ng/L (Russell et al., 1996).

Studies have found that mean TBT surface water concentrations have significantly decreased in San Diego Bay, following legislative restriction on the use of organotin antifouling paints in California. Regression analysis of the San Diego data suggests that surface water concentrations would decrease by 50% in 8 to 24 months. It was found that sediment TBT concentrations in San Diego Bay did not reflect recent decreases in water column values and were variable among stations over time, and that tissue concentrations in *Mytilus edulis* have generally declined in San Diego Bay since February 1988 (significantly since April and July 1990), Valkirs et al. (1991).

Similar findings have been reported for the Chesapeake Bay by Huggett et al. (1992) for the Hampton, Virginia area of the Bay. Surface water samples analyzed after the passage of the Organotin Antifouling Paint Control Act (OAPCA) of 1988 in marinas and yacht clubs indicated that TBT concentrations had significantly decreased when compared to results of earlier studies by Huggett (1986, 1987) and Huggett et al., (1986), U.S. EPA Chesapeake Bay Program, (1987), and Hall (1986; 1988); Hall et al. (1986; 1987).

The EPA Report to Congress (U.S. EPA, 1996) is a summary of the status of development of alternatives to TBT. The driving force is to develop an alternative to TBT, which could compete in the \$ 500 million per year total antifoulant paint market (C&E News, Oct 14, 1996). The TBT copolymer used in deep-ocean going vessels represents between 65-70 percent of this market. The goal is to develop a non-toxic (no effect on non-target organisms) antifoulant, which effectively inhibits the formation of biofilms and prevents biofouling. The major finding of the EPA 1996 Report (which has not been updated) was that "an alternative antifoulant as effective as TBT self polishing copolymer paints has not been found." They also reported that the principal alternatives today to TBT antifouling paints are copper-based. However, hulls treated with copper-based paints were reported to foul within 15 to 18 months due to formation of a "green layer" on the surface of the hull. The green layer is the reaction of copper to seawater, which results in the formation of a coating of insoluble cupric salts, preventing the release of copper from the paint underneath. Once the green layer is present, the antifoulant protection is no longer effective. Underwater hull scrubbing is required to remove the green layer and attached fouling organisms and with frequent scrubbing, the period of protection can be extended for up to 30-36 months depending on water temperatures. Revised estimates on fuel savings from the use of TBT by the Navy ranged from 18 to 22 percent of the total fuel consumption (U.S. EPA, 1996).

EPA has recently noted that noted that the use of copper is coming under increasing regulatory pressure with some coastal states restricting the amount of copper that may be discharged into local harbors during hull cleaning and washing. These regulations may impact the U.S. Navy's use of copper in antifoulant paints and leave the Navy without alternatives that meet their requirements. The Navy has held a workshop on the chemistry, toxicity and bioavailability of copper and its relationship to regulation in the marine environment to improve the scientific understanding of copper in the marine environment and attempt to develop a solid scientific basis for future approaches to copper regulation (Seligman and Zirino, 1998). In addition, the Navy has funded the development of in the water cleaning systems for copper that also collect all waste and wastewater for treatment (Bohlander &

Montemarano, 1997). It also should be noted that both Holland and Sweden have recently introduced regulations on antifouling paints for pleasure vessels containing copper as effective September 1, 1999. Canada has set the release rates of copper in antifouling paints at 40 mg/cm²/day. Copper is a potential toxin to marine organisms (Lewis and Cave, 1982; and Goldberg, 1992). It should also be noted that the U.S. Department of Defense and the U.S. Environmental Protection Agency have been working on the Uniform National Discharge Standards (UNDS) which will regulate the amount of biocidal discharges from antifouling coatings into the sea by December 2000, with the current release rates under consideration for copper less than the 40 mg/cm²/day. (see UNDS Website: <http://206.5.146.100/n45/doc/unds/SITEMAP/ITEMAP.HTML>).

TBT concentrations in water, sediment, and biota have generally declined. Evans (1999b) has an excellent summary paper on the concentrations and environmental effects as a measure of the effectiveness of national regulations. TBT concentrations in surface marine waters have declined in Arcachon Bay, France (Alzieu et al., 1986, 1989) and in the UK (Cleary, 1991; Waite et al., 1991, 1996; Dowson et al., 1992, 1993a, 1993b and 1994) the USA (Valkirs et al., 1991; Huggett et al., 1992, 1996; and Uhler et al., 1993) and in the Gulf of Mexico from Wade et al., 1991; and Champ and Wade, 1996; Garcia-Romera et al., 1993) and Australia (Batley et al., 1992). Tissue concentrations in molluscs have declined (Valkirs et al., 1991; Wade et al., 1991; Champ and Wade, 1996; Waite et al., 1991, 1996; and CEFIC, 1994).

Exceptions to this general decline of TBT in bottom sediments have been reported as hot spots associated with ship channels, ports, harbors, and marinas in Galveston Bay (Wade et al., 1991), Hong Kong (Ko et al., 1995), the Netherlands (Ritsema et al., 1998), Iceland (Svavarsson and Skarphédinsdóttir, 1995) and in Israel (Rilov et al., 1999).

Oyster culture has recovered in France (Alzieu et al., 1986, 1989 and Alzieu, 1991 and 1996). In southern England, Waite et al. (1991; 1996; and Dyrinda, 1992) reported improved oyster culture. For Australia, Batley et al. (1992) have reported improvements in oysters. Minchin et al. (1987) have reported improvements for

scallops and Minchin, (1995) and for flame shells in Ireland.

The literature has also reported wide spread decline in *Imposex* and population recovery for dogwhelks (*Nucella* spp.): England (Evans et al., 1991; Douglas et al., 1993; Gibbs and Bryan, 1996a 1996b); Scotland (Evans et al., 1994 and 1996; and Nicholson et al., 1998); Ireland (Minchin et al., 1995); Norway (Evans et al., 1996); and Canada (Tester and Ellis, 1995; Tester et al., 1996).

COMMENTS ON THE SCIENTIFIC BASIS FOR THE REGULATION OF TBT

It is interesting to note, that the "movement" to regulate TBT based antifouling paints during the 1980's was initially based on "correlation" and "generality" type science (see Salazar and Champ, 1988). Peruse the bioassay discussions in White and Champ (1984), and see Evans et al. (1996) and Evans (1997 and 1999a; 1999b) for a discussion on *Imposex*. The Salazar and Champ (1988) paper was a preliminary review of the science that was prepared for an Oceans '88 conference proceedings to stimulate discussions. However, it was published about the same time that OAPCA was passed in the U.S. and interest in TBT and support for further research declined (Champ and Seligman 1996a). Fortunately this was not true on a global basis. Some of these concerns have been revisited and are discussed in a collection of papers reprinted and submitted by the paint industry to the MEPC by the Organotin Environmental Program Association (ORTEP, 1996, 1997 and 1998). Many of these points were discussed at the 1998 Annual Meeting of the American Chemical Society in Dallas (Rouhi, 1998) and in Champ (1998). In addition, papers were presented at the Oceans '99 Conference in Seattle (September, 1999) that discussed the science being used in the regulatory process (see Brancato and MacLellan, 1999; Cardwell et al., 1999; Damodaran et al., 1999; Evans, 1999c; Evans and Nicholson, 1999; Evans and Smith, 1999; MacLellan et al., 1999; and Toll et al., 1999). Several of these papers delineate problems with data quality and quantity, protocols and question the emphasis of the data and the information that is being utilized as a basis for proposed additional regulation. *However, these*

points are moot if comparable and environmentally friendly alternatives to TBT are available and acceptable (Champ, 1998, 2000).

The Scientific Controversy

Early concern was expressed that most of the evidence the regulatory process considered to be significant came from bivalve mollusks: (1) it was believed that mollusks were more sensitive than other animal groups to TBT, (2) Many bivalves have a cosmopolitan distribution and are commonly maintained in the laboratory, (3) filter-feeding bivalves may be more susceptible to TBT due to their feeding strategy, and (4) many bivalves have an economic importance in the commercial shellfish industry (Champ and Seligman, 1999b; 1999c). A significant and subtle distinction that needs to be kept in mind is the difference between the environmental impact of TBT on the shellfish industry and the environmental impact of TBT on natural shellfish populations. The point is that the effects on cultured shellfish do not necessarily demonstrate similar ecological effects in a typical natural situation. A second point is related to public definition of “acceptable” land use. It is difficult to appreciate being interested in culturing shellfish in areas adjacent to marinas and shipyards given their history of being defined as “polluted” due to acute and chronic contamination problems (Champ, 1983). Ports, harbors, and marinas are publicly approved marine land uses. These facilities are usually located in highly protected areas with low flushing rates, long water mass retention times, oil spills, high levels of contaminants, and high silt loads which are not optimum conditions for culturing filter-feeding bivalves.

In Europe, the critical evidence for the initial regulations in the mid 80’s, was associated with shell thickening in oysters (*Crassostrea gigas*) and imposex in dog-whelks (*Nucella lapillus*). In the U.S., the early critical evidence was associated with laboratory studies that reportedly demonstrated unacceptable effects on growth and development in oysters (*C. gigas*, *Ostrea edulis*) and clams (*Mercenaria*) (Champ, 1986). All of this evidence was based on only four species, a similar number of laboratory tests and field observations, generally unsupported by chemical measurements and not published in peer reviewed

journals. In general, the laboratory studies utilized questionable methodology and field studies lacked the necessary scientific rigor.

Bioaccumulation of TBT from Sediments

In what may become a classic regulatory textbook debate and case study, are the results of a 5-year study of TBT-contaminated sediments associated with an U.S. EPA Superfund site in Washington State. The issues unresolved are summarized in a U.S. EPA Region 10 Technical Memorandum (for addressing unanswered questions) that is entitled: “Topics Related to the Tributyltin Study at the Harbor Island Superfund Site, Seattle, Washington” (Keeley, 1999, Personal Communication). During EPA Superfund remedial investigations at the Harbor Island Site (Weston, 1994), TBT had been previously identified as a contaminant of potential concern due to elevated concentrations in the marine sediment (higher concentrations ranged from 10 to 50 ppm dw TBT).

Because there are no established Federal or State sediment quality guidelines or standards for evaluating TBT concentrations in sediment, the U.S. EPA formed an interagency working group to identify and evaluate approaches to deriving an effects-based sediment cleanup concentration for use at Superfund sites in Puget Sound, Washington. Most of the available literature presented toxicity of TBT for water, and only two studies (covering four species) evaluated toxicity associated with sediment concentrations of TBT (U.S. EPA, 1996a). The working group also proposed the calculation of an Apparent Effects Threshold (AET) value, which could be used as a sediment criteria for TBT, using available chemical (bulk sediment) and biological (sediment toxicity, benthic infauna) data from Puget Sound. The working group found that: (1) Existing Puget Sound data did not support a clear identification of an AET value for TBT; (2) A maximum no-effect concentration could often not be established because, in several cases, the highest sediment TBT concentration was associated with no biological effects and was also the highest concentration measured among all the stations sampled; (3) Good correlations were not found between bulk TBT sediment concentrations and laboratory toxicity and *in situ* benthic community responses; and (4) Based on an evaluation of available information, “bulk sediment concentrations of TBT were a poor

predictor of bioavailable TBT" (U.S. EPA 1996a). Further, the working group recommended, based on a general understanding of chemical partitioning and the lack of observed relationships between bulk sediment TBT and adverse ecological effects, that when TBT is a contaminant of concern in sediment, pore water concentrations of TBT should be measured, and toxicity testing or bioaccumulation testing (*in situ* or laboratory) be conducted to confirm the ecological significance of concentrations measured in pore water. The working group did not provide recommendations for specific bioaccumulation test species, because it was believed that additional work needed to identify the most appropriate species (ESI, 1999a).

In a series of subsequent TBT related studies, a consortium of Harbor Island waterfront property owners (the Port of Seattle, Lockheed Martin Corporation and Todd Shipyards Corporation) funded a study to evaluate the bioavailability of and the potential effects associated with TBT in sediments at the Superfund site. The overall purpose of this study was to develop a site-specific, effects-based TBT tissue trigger concentration that could be used to determine the need for remediation of TBT-contaminated sediments. In this study, effects considered relevant for the development of a site-specific tissue trigger value were mortality; reduced growth; and reproductive impairment. The normal TBT effects cited in the literature, such as bivalve shell thickening or induction of (early stage) imposex or intersex in meso- and neogastropods, were not appropriate in this evaluation, because (1) these biological responses do not have established connection to population-level effects, and (2) there is a lack of suitable habitat at the site for the species (oysters, mesogastropods, and neogastropods) typically affected by shell thickening, imposex and intersex. The study site is a deep (-30 to -60 ft mean lower low water), industrialized channel of subtidal sediments within the Duwamish River Estuary. Very little intertidal habitat is available, due to extensive channelization and dredging of the waterway, and no commercial or recreational shellfish beds occur. In addition, gastropods typically are not a large component of the benthic community at the site, and mesogastropods and neogastropods are very limited in abundance (ESI 1999a). The study was performed in accordance with a Sampling and Analysis Plan

(SAP), prepared by ESI (1998) that was reviewed and commented on by all reviewers prior to its approval by U.S. EPA, and resultant data from the TBT study were determined to be of high quality by EPA (ESI, 1999b).

The evaluation of TBT sediments from the Harbor Island sediments was conducted in two studies. First, a TBT literature review was conducted to identify global paired tissue residue and effects data for marine invertebrates and fish (ESI 1999a). The tissue residue data were used to estimate a site-specific, effects-based tissue trigger concentration for TBT (ESI 1999a). Second, sediment samples were collected throughout the study site for chemical and biological testing (ESI 1999b). TBT concentrations were measured in bulk sediments and pore water samples; a subset of sediment samples collected was used for bioaccumulation testing. With approval from all involved agencies and consistent with national guidance, bioaccumulation testing was conducted to determine site-specific exposures to two marine invertebrate species: (1) a bivalve (*Macoma nasuta*) and (2) a polychaete (*Nephtys caecoides*). No approved marine sediment toxicity bioassay protocols for test species that have demonstrated sensitivity to TBT were available (U.S. EPA, 1996a), so no toxicity testing was conducted. The resulting tissue TBT concentrations were then compared to the effects-based trigger concentration derived from the literature (ESI 1999b; Keeley, Personal Communication).

Results of this study were that the survival of the laboratory test organisms was high, and the lipid content of the organisms exposed to test sediments was similar to controls, which suggest to many of the projects reviewers that the organisms were in good physiological health during the exposure period. A site-specific tissue trigger (3 mg/kg DW TBT) was estimated (Meador, 2000) for the study site for evaluating bioaccumulation data from the study area, and for the 20 stations sampled and tested at the site, none of the tissue samples from the bioaccumulation tests exceeded the tissue trigger value of 3 mg/kg DW TBT. Thus, no cleanup of TBT sediments was recommended. The value of 3 mg/kg DW TBT, which was derived from paired tissue residue effects data in the literature, is estimated to be the tissue residue

associated with reduced growth in a number of invertebrate species. The level is however, very similar to the overall geometric mean of paired effect/no-effect data and the estimate of a sublethal effects level based on a multi-species acute-to-chronic effects ratio for the study area.

The development of tissue residue effects thresholds is part of EPA's overall strategy for management of specific contaminants in sediments in the US rivers and estuaries. The lack of TBT bioaccumulation from sediments in these studies is not understood, creating more unanswered questions and confusion in the data and suggests that further studies are needed prior to the development of a protocol for estimating TBT tissue level triggers for regulatory use. Results from the study also found that TBT tissue concentrations were most strongly correlated with dw-sediment and carbon-normalized sediment TBT concentrations, and there were weak correlations with filtered and unfiltered pore water TBT concentrations. If there is no relationship between levels in sediments and bioaccumulation levels in tissues, then the TBT in the sediments has been shown to not be bioavailable. For the determination of ocean dumping for dredged materials, the decision has to do with whether a species has accumulated more than 3 mg/kg DW TBT.

After completing the Harbor Island TBT bioaccumulation studies, the U.S. EPA (1999) prepared a Technical Memorandum to address topics of interest identified by EPA and other agency reviewers on issues related to the findings presented in the above study (ESI, 1999c). Several scientists reviewing the results of the Harbor Island studies had a difference of opinion in the interpretation of the results. Some reviewers of ESI (1999b) indicated that the measured TBT bioaccumulation in test organisms for this project was less than they would have expected from the measured sediment and pore water TBT concentrations in site samples. This concern was based in part on a comparison of the bioaccumulation test results with studies reported in the literature and with other similar studies performed in the general Harbor Island area. Some reviewers suggested that several test parameters (e.g., species selection, exposure regime of tests, organism health) might have influenced the results.

Salazar and Salazar (1999a, b, in preparation) in reviewing the Harbor Island bioaccumulation studies believe that the major lesson learned from this study and their separately conducted caged bivalve bioaccumulation studies are that lab tests don't predict nature very well, or adequately consider equilibrium and energetics. They have listed the following specific lessons learned from their research on TBT uptake by mussels that: (1) Lab tests generally over-estimate toxicity; (2) Lab tests generally under-estimate bioaccumulation; (3) Bivalves are sensitive test species; (4) Exposure period should be determined by equilibrium; (5) Growth rate affects bioaccumulation potential; (6) Quantifying health is important in data interpretation; and (7) Tissue chemistry can be used to predict effects. Salazar and Salazar (1987; 1989; 1996) and Salazar et al. (1987) have found that survival and growth effects of TBT were over-estimated based on laboratory tests and mesocosm studies. They placed caged mussels at the seawater intake to test tanks and found that growth rates were about 4 times faster outside the test tanks compared to growth in the control tanks.

In the Harbor Island studies, the issue is the interpretation of the tissue chemistry data and Salazar and Salazar (1996a b, in preparation) believe that, even though the U.S. EPA followed all state and national guidance and accepted state-of-the-art testing protocols, they believe that laboratory exposures have under-estimated bioaccumulation levels due to animal health from test conditions. Meador (Personal Communication) suggests that *Macoma* in these tests were more than likely ventilating clean overlying water, reducing its exposure to TBT. Generally speaking, bivalves are extremely sensitive to food and flow rate and growth rates seldom if ever achieve the growth rates of animals in nature. Laughlin (1996) reported that BCF is related to growth rate and that the highest growth rates were associated with the highest BCFs. Laughlin referred to this as the concentration dependence of TBT accumulation. Widdows et al, (1990) found that the operative mechanism is that growth rate is also related to filtration rate. Laughlin (1996) measured BCFs of only about 5,000 compared to an average of about 30,000 from Salazar (1989); and Salazar and Salazar (1996) transplanted mussels, suggesting that Laughlin's animals may have been under severe stress.

The 28 day exposure bioaccumulation tests in the Puget Sound Studies with the marine bivalve *Macoma nasuta* (which is a facultative feeder – both filter feeding and deposit feeder) did not reach steady state, when the test was extended to 45 days, and the results may have reflected test conditions in which *Macoma* may have been stressed. Originally, EPA proposed modifying the test procedure in accordance with Test Sediment Renewal (EPA Guidance Manual on Bedded Sediment Bioaccumulation Tests (EPA/600/R-93/183) which recommends complete sediment renewal for test longer than 28 days. Bruce Boese (EPA Newport Laboratory and an author of the manual) suggests that the primary reason for performing sediment renewal was to give the animals more “food”. For the Harbor Island tests, it was decided to add 0.5 cm of sediment to the test chambers every 7 to 10 days for the entire test (overlaps weekends). Questioned in the study was also the use of lipid content at the beginning and end of the test was considered as an endpoint to evaluate potential stress on the test organisms. Boese (Personal Communication) felt that lipid content of *Macoma* does not give you any information about the health of *Macoma*, and that loss/gain of lipids is primarily related to reproduction.

Laboratory bioassays have become an environmental test industry and big business in making regulatory decisions. Their simplicity, cost and reproducibility are very attractive to regulatory policy and decision-makers. However, their scientific value or merit has been repetitively questioned. White and Champ (1983) addressed this issue of “The Great Bioassay Hoax” and Salazar (1986) asked similar questions regarding the application of traditional laboratory toxicity tests to assessments of TBT. Salazar and Salazar have raised these questions to a higher level of sophistication but the old problems still remain. Scientists in the bioassay testing business hesitate to challenge an accepted regulatory test, because of a lack of a replacement, and the process to get one accepted, but still need to strive to develop standardized tests that validate and represent what an organism actually experiences in the environment.

Salazar and Salazar (1999a, b, in preparation) also feel that the other interesting issue here is that they believe that the *Macoma* bioaccumulation test may be flawed for the following reasons: (1) since the ASTM

protocols do not require any effects measurements, one can never be sure of the health of the test organisms, (2) the largest and slowest-growing animals generally have the lowest tissue concentrations in transplant studies, and (3) people tend to forget that *Macoma* is a facultative deposit feeder, and can either filter- or deposit-feed. Recent summary papers have reported that many benthic invertebrates are quite plastic in their feeding mode and readily shift back and forth from filter- to deposit-feeding depending on local environmental conditions and available food and can select between clean and filtered seawater and highly contaminated sediment.

Langston and Burt (in preparation) found that concentrations in tissues of *Scrobicularia plana* (a deposit feeding clam) in the UK reached equilibrium in tissues after 40 days of exposure. They also reported that sediments are an important vector for TBT uptake in deposit-feeding clams. They also concluded that it is particulate rather than desorbed TBT, which is most significant. Laughlin (1996) reports that bioaccumulation factors appear to be high, but field studies, in particular, have not necessarily carefully characterized the route of uptake (water or food).

Salazar and Salazar (1999) have found numerous examples where bivalves have been the most sensitive test species. Their predicted tissue burden for effects in mussels is an order of magnitude lower than that for amphipods based on the work of Meador (1997 and references cited there in) and others. Theory suggests that tissue concentrations for effects should be relatively constant across species and that appears to be true for particular endpoints like growth. The problem is that it is relatively difficult to measure growth rate in an amphipod. The difference in sensitivity is due to the growth rate endpoint in bivalves and the mortality endpoint in amphipods which theory suggests is about an order of magnitude different (McCarty, 1991; McCarty and Mackay, 1993). An additional problem with most laboratory tests is that they were not originally selected and standardized by equilibrium kinetics and steady state.

Amphipod tests are routinely conducted for only 10 days, even though Meador (1997, 2000) has found that it takes about 45 days to reach chemical equilibrium or steady state. This may explain why there appears to

be a disconnect between sediment chemistry, laboratory toxicity tests, and benthic community assemblages using the sediment quality triad. This has led to suggestions of using tissue chemistry to predict effects (McCarty, 1991; McCarty and Mackay, 1993). Subsequently Salazar and Salazar (1991; 1998; and Submitted) developed the exposure-dose-response triad that relies on tissue chemistry to make the link between the various effects endpoints. This relates to Salazar's point of growth rate affecting bioaccumulation potential. Sick and dying animals do not accumulate much TBT, which is why it is essential to confirm the health of the test animals.

With TBT data, they have been able to predict where effects will occur based on where the relationship between water or sediment and tissue TBT begins to change. This was first demonstrated in a graph published in Salazar and Salazar (1996) that plotted the relationship between water and tissue TBT. They found that grouping the data above 105 ng/L gave one regression and at 105 ng/L or lower that it gave a very different regression. The Salazar's recently replotted the Langston and Burt (1991) data and found exactly the same relationship, which Langston concurred. With Langston and Burt's data, they found effects in *Scrobicularia* to occur between 0.1 to 0.3 ug/g TBT dry weight in sediment, which agrees with Meador's data for effects on the polychaete *Armandia brevis* (Meador and Rice, In Press). The Salazar's summarized their findings in a paper presented at the SETAC (1999) meeting in Philadelphia. This paper is being expanded to emphasize the significance of field data over laboratory data in predicting effects and will be submitted to the Journal of Marine Environmental Research. They concluded that these data sets: (1) supports their hypothesis that one can predict the concentrations where effects will begin to occur based on the relationship between external concentrations and tissue burdens; (2) demonstrates that the concept may work for both water and tissue; and (3) suggests that tissue burdens associated with effects (acute 10X > chronic) are relatively constant across marine organisms.

ANTIFOULING BIOCIDES AND INVASIVE SPECIES

Recent research has suggested that hull biofouling will

likely play a much greater role in introduction of invasive (exotic) species following a global ban on the use of TBT in antifouling paints. The 10th International Congress on Marine Corrosion and Fouling (February, 1999) in Melbourne Australia, included two special sessions on invasive species transported on vessel hulls. Stephan Gollasch, from the Institute for Marine Sciences in Germany gave a keynote address on the importance of ship hull fouling as a vector of species introductions into the North Sea. Dan Minchin presented a paper on data and information from Ireland and Mary Sue Brancato presented data from the U.S. (see also Brancato and MacLellan, 1999). Historically invasive species from the hulls of ships has been mostly an exotic marine algae and plants problem due to the speed and size of ships and water quality in ports.

Minchin estimated that 1.8 million marine organisms could exist on the hull of a severely biofouled vessel (Minchin, Personal Communication). However, after the introduction and use of TBT in the early 70's, fouling on hulls was not considered a significant source problem for invasive species, because in general hulls were cleaner. Considering the coincidence of global climate fluctuations and the proposed global ban on the use of TBT, invasion of species via the biofouling community on fouled hulls of ships may eventually constitute a greater threat than those in ballast water (Minchin and Sheehan, 1999).

Minchin is also concerned that there is a correlation between ship hull hitchhikers and water temperature changes. Ships pass through rapid water temperature fluctuations while entering harbors and channels and ports from the open ocean. These sudden temperature swings may initiate spawning triggering invasive species introduction in ports and port channels. Populations could easily become established in the invaded U.S. port because the U.S. Clean Water Act has greatly cleaned up (reduced pollution) U.S. ports over the years. In the past, the level of contamination in most ports has reduced the probability of the invading organism becoming established.. With the movement to clean up ports and harbors world wide, the risk of introduction has greatly increased. Minchin believes that IMO must have available replacements that are as effective as TBT, in providing the same degree of protection to coastal waters from invasive species as TBT has for the past three decades. To ban

it, we would face serious introduction of invasive species in the temperate environments. Their environmental impacts include changes in biodiversity, food webs, trophic levels competition, and the introduction of disease organisms and parasites.

It has been estimated that over 6000 species have been introduced in the U.S. The introduction of the lamprey eel and zebra mussel in the Great Lakes are examples of major invasive species. The zebra mussel has had detrimental effects on lakeside piers, industrial facilities and public beaches. Another example the European Green Crab (*Carcinus maenas*) has the potential to impact the \$20 million dollar crab industry in the State of Washington alone (Brancato, 1999). Additional examples of invasive species are the Toxic Japanese dinoflagellates and the Northern Pacific sea star, which have infested New Zealand and Australia. The American comb jellyfish has greatly impacted the anchovy industry in the Black Sea.

In his keynote address at the 10th International Congress on marine Corrosion and Fouling, Stephan Gollasch reported on historical studies of invasive species in the North and Baltic Seas and compared vectors of introduction including ballast water and hull fouling from 200 ships. In the 1992 to 1995 time frame, Gollasch reported that most of the non-native species with the highest potential for establishment were from fouled hulls, with 53% of the marine exotic species found in the North Sea introduced by shipping and 98% of the hulls sampled revealed non-native species (Reise et al., 1999). Of the species connectable to shipping, 66% were introduced from the hull, 34% from ballast tanks. Gollasch, the second author of Reise et al. (1999) paper is also a scientific advisor and member of the German delegation for the ballast water working group at IMO's MEPC 43. He believes that IMO should consider the hull fouling dilemma in its assessment of the ban of TBT and balance the risk of introduction of invasive species harming local ecosystems with the environmental risks of TBT on non-target species in their decision-making process. He has found that most of the species of high concern are transported in ballast water including cholera bacteria and phytoplankton algae causing harmful algal blooms, but he believes the risk of species introduction

from ships hulls is increasing and without TBT it could be even worse (Gollasch, 1999, personnel communication).

TBT CONTAMINATION OF SEDIMENTS IN PORTS AND HARBORS

If TBT is banned by international treaty as proposed by MEPC 42, the future cost of removal of dredged material from harbors and waterways will probably increase significantly. An example of how regulation can increase disposal of dredged material costs is seen in the two alternatives available to the Port of NY/NJ for immediate disposal of dredge spoils. The Mud Dump Site (located 3 miles offshore in the open waters at the mouth of the harbor) has been operational for many decades and has been the traditional disposal area and can accept Category I dredged materials. Category II and III contaminated "spoils" have to be disposed of at an upland hazardous waste disposal facility, however, from 1977 to 1991, 90% of all NY/NJ dredge spoils were tested and classified Category I and only 1 to 2 % were Category III. However, in 1991 the US EPA replaced the existing tests in the NY region and added new bioassay testing which altered Category I, II, and III determinations.

For Category II and III dredged material, the currently available alternative is upland disposal at a hazardous materials storage facility and none are available in the near vicinity. Howland Hook Terminal in Staten Island shipped 150,000 yd³ of sediment via barge and rail to Utah at a cost of \$17 million or over \$110/yd³. Traditional fees for dumping dredge materials at the Mud Dump Site are in the area of \$10/yd³.

If TBT ("as perhaps the most toxic substance ever deliberately introduced to the marine environment by mankind") is banned by an international convention (it will be the first chemical by name to have its own convention or treaty) it could then be considered equal or more hazardous than Category III compounds. As such it might greatly increase the cost of disposal of dredged materials from most ports and harbors that are contaminated with TBT, because of its persistence and its universal distribution in bottom sediments of ports and ship channels.

An additional concern for the paint companies, shipyards and shipping industry may be that in the future that they have bear the liability for cost contained dredging. It may be that the liability for the additional or special costs of dredging and disposal of TBT contaminated dredged materials from ports and ship channels might revert back in the courts to sources such as have the costs of health settlements from smoking in the courts. The impact on TBT contamination in port sediments on future shipping and port development is significant, for example, plans to dredge the Tyne in Newcastle (UK) may be abandoned, because of extremely high TBT concentrations in the river sediments, and the concern that organotins will desorb from particles on agitation during dredging and disposal of dredge material at sea (Mark G.J. Hartl, Personal Communication). Approval for dredging is pending on the outcome of a survey being conducted by CEFAS, Burnham On Crouch.

REFERENCES CITED

- Alzieu, Cl., J. Sanjuan, J. Deltreil and M. Borel. 1986. Tin contamination in Arcachon bay: effects on oyster shell anomalies. *Marine Pollution Bulletin*. **17**:494-498.
- Alzieu, Cl., J. Sanjuan, P. Michell, M. Borel and J.P. Dreno. 1989. Monitoring and assessment of butyltins in Atlantic coastal waters. *Marine Pollution Bulletin*. **20**(1):22-26.
- Alzieu, Cl. 1991. Environmental problems caused by TBT in France: Assessment, regulations, prospects. *Marine Environmental Research*. **32**:7-17.
- Alzieu, C., P. Michel, I. Tolosa, E. Bacci, L.D. Mee and J.W. Readman. 1991. Organotin compounds in the Mediterranean: a continuing cause for concern. *Marine Environmental Research*. **32**(1-4):2261-270.
- Batley, G.E., C.I. Brockbank. And M.S. Scammell. 1992. The impact of banning of tributyltin-based antifouling paints on the Sydney rock oyster, *Saccostrea commercialis*. *Sci. Total Environ*. **122**:301-314.
- Boese, 1999. Personal Communication. USEPA Newport Laboratory, Oregon.
- Bohlander. G.S. and J.A. Montemarano. 1997. Biofouling, fleet maintenance and operational needs. *Naval Research Reviews*. (ONR) Vol. **XLIX**: 9-18
- Brancato, M.S. and D. MacLellan. 1999. Impacts of invasive species introduced through the shipping industry. Proceedings Oceans '99 International Symposium on the Treatment of Regulated Discharges from Shipyards and Drydocks. Marine Technology Society. Washington, D.C. This Volume.
- Brancato, M.S. 1999. Personal Communication. Parametrix, Inc., 5808 Lake Washington Boulevard N.E., Suite 200. Kirkland, Washington 98033. Tel. (425) 822-8880. Fax (425) 889-8808.
- Cardwell, R., M.S. Brancato, J. Toll, D. DeForest and L. Tear. 1997. Aquatic ecological risks posed by Tributyltin in U.S. surface waters: Pre-1989-1997 Data. *Environmental Toxicology and Chemistry*. **18**(3):567-577.
- Cardwell, R., M.S. Brancato, J. Toll, D. DeForest and L. Tear. 1999. Aquatic ecological risks posed by Tributyltin in U.S. surface waters: Pre-1989-1997 Data. Proceedings Oceans '99 International Symposium on the Treatment of Regulated Discharges from Shipyards and Drydocks. Marine Technology Society. Washington, D.C. This Volume.
- CEFIC (European Chemical Industry Council). 1992. TBT copolymer antifouling paints: the facts. Document MEPC 33/INF.14 for the 33rd meeting of the Marine Environment Protection Committee of the International Maritime Organization. London.
- CEFIC (European Chemical Industry Council). 1994. Use of organotin compounds in anti-fouling paints. Results of TBT monitoring studies. Document MEPC 35/17 for the 35th meeting of the Marine Environment Protection Committee of the International Maritime Organization. London.
- CEFIC (European Chemical Industry Council). 1996. Harmful effects on the use of antifouling paints for ships: A review of existing antifouling paints and the development of alternative systems. Document MEPC 36/14/4. for the 36th meeting of the Marine Environment Protection Committee of the International Maritime Organization. London.

- Champ, M. A. 1983. Etymology and Use of the Term "Pollution." *Canadian Journal of Fisheries and Aquatic Science*. 40(Suppl. 2):5-8.
- Champ, M.A. 1986. Introduction and overview. Proceedings Oceans '86 Organotin Symposium. Marine Technology Society. Washington, D.C. Vol. 4:i-viii.
- Champ, M.A. and F.L. Lowenstein. 1987. TBT: The dilemma of hi-technology antifouling paints. *Oceanus*. Woods Hole Oceanographic Institution. 30(3):69-77.
- Champ, M.A. and L.W. Pugh. 1987. Tributyltin antifouling paints: Introduction and overview. Proceedings Oceans '87 International Organotin Symposium. Marine Technology Society. Washington, D.C. Vol. 4:1296-1308.
- Champ, M.A. and P.F. Seligman. 1996a. *Organotin: Environmental Fate and Effects*. (Eds) Chapman & Hall. London. 674p.
- Champ, M.A. and P.F. Seligman. 1996b. An Introduction to organotin compounds and their use in antifouling coatings. Chapter 1. *In: Organotin: Environmental Fate and Effects*. Champ and Seligman (Eds). Chapman & Hall. London. pp. 1-26.
- Champ, M.A. and P.F. Seligman. 1996c. Research information requirements associated with the environmental fate and effects of organotin compounds. Chapter 29. *In: Organotin: Environmental Fate and Effects*. Champ and Seligman (Eds). Chapman & Hall. London. pp. 601-614.
- Champ, M.A. and T.L. Wade. 1996. Regulatory policies and strategies for organotin compounds. Chapter 3. *In: Organotin: Environmental Fate and Effects*. Champ and Seligman (Eds). Chapman & Hall. London. pp. 55-94.
- Champ, M.A. 1998. The tributyltin antifouling paint controversy. *Sea Technology* 39(7):113.
- Champ, M.A. 1999a. The need for the formation of an independent, international marine coatings board. *Marine Pollution Bulletin*. 38(4):239-246.
- Champ, Michael A. 1999b. Incorporating Good Environmental Science in the Current Organotin Regulatory Debate. Editorial, Lessons Learned. SETAC November Newsletter.
- Champ, M.A. 2000. The Coating Conundrum. Editorial. *Maritime Reporter and Engineering News*. (January). Vol. 1, pp 46-48.
- Champ, M.A. (In Press for 2000). A Review of Organotin Regulatory Strategies, Pending Actions, Related Costs and Benefits. *Science of the Total Environment*. 75p.
- Cleary, J.J. 1991. Organotin in the marine surface microlayer and sub-surface waters of Southwest England: relation to toxicity thresholds and the U.K. environmental quality standard. *Marine Environmental Research*. 32(1-4):213-222.
- Damodaran N., J. Toll, M. Pendleton, C. Mulligan, D. DeForest, M. Kluck, M.S. Brancato and J. Felmy. 1999. Cost Analysis of TBT Self-Polishing Copolymer Paints and Tin-Free Alternatives For Use On Deep-Sea Vessels. Proceedings Oceans '99 International Symposium on the Treatment of Regulated Discharges from Shipyards and Drydocks. Marine Technology Society. Washington, D.C. This Volume.
- Douglas, E.W., S.M. Evans, C.L.J. Frid, S.T. Hawkins, T.S. Mercer, and C.L. Scott. 1993. Assessments of imposex in the dogwhelk (*Nucella lapillus*) and tributyltin along the north-east of England. *Invertebrate Reproduction & Development*. 23:243-248.
- Dowson, P.H., J.M. Bubb, and J.N. Lester. 1992. Organotin distribution in sediments and waters of selected east coast estuaries in the UK. *Marine Pollution Bulletin*. 24:492-498.
- Dowson, P.H., J.M. Bubb and J.N. Lester. 1993a. Temporal distribution of organotins in the aquatic environment: Five years after the 1987 UK retail ban on TBT based antifouling paints. *Marine Pollution Bulletin*. 26(9):487-494.
- Dowson P.H., J.M. Bubb, J.N. Lester. 1993b. Depositional profiles and relationships between organotin compounds in freshwater and estuarine sediment cores. *Environmental Monitoring & Assessment*. 28:145-160.
- Dyrynda, E.A. 1992. Incidence of abnormal shell thickening in the Pacific oyster *Crassostrea gigas* in Poole Harbour (UK), subsequent to the 1987 TBT restrictions. *Marine Pollution Bulletin*. 24:156-163.
- ESI (EVS Solutions Inc). 1998. Waterway Sediment Operable Unit, Harbor Island Superfund Site: Sampling and analysis plan for TBT study. Prepared for the Port of Seattle, Lockheed Martin

- and Todd Shipyards for submittal to EPA Region 10. Seattle, WA. EVS Solutions, Inc. Seattle, WA. 30p. 5 Appendices.
- ESI (EVS Solutions Inc). 1999a. Waterway Sediment Operable Unit, Harbor Island Superfund Site: Review of Tissue Residue Effects Data for Tributyltin, Mercury, and Polychlorinated Biphenyls. Prepared for the Port of Seattle, Lockheed Martin, and Todd Shipyards for submittal to EPA Region 10. Seattle, WA. EVS Solutions, Inc. Seattle, WA. 37p.
- ESI (EVS Solutions Inc). 1999b. Waterway Sediment Operable Unit, Harbor Island Superfund Site: Tributyltin in marine sediments and the bioaccumulation of tributyltin: combined data report. Prepared for Port of Seattle, Lockheed Martin Corporation, and Todd Shipyards Corporation. EVS Solutions, Inc. Seattle, WA. 42p. 7 Appendices.
- ESI (EVS Solutions Inc). 1999c. Waterway Sediment Operable Unit, Harbor Island Superfund Site: Technical Memorandum: Topics related to the TBT field study at the Harbor Island Superfund Site, Waterway Sediment Operable Unit. Prepared for the Port of Seattle, Lockheed Martin Corporation, and Todd Shipyards for submittal to USEPA Region 10 Seattle, WA. EVS Solutions, Inc. Seattle, WA. 15p.
- Evans, D.A. and R.J. Huggett. 1991. Statistical modeling of intensive TBT monitoring data in two tidal creeks of the Chesapeake Bay. *Marine Environmental Research*. **32**(1-4):169-186.
- Evans, S.M., A. Hutton, M.A. Kendall, and A.M. Samosir. 1991. Recovery of dogwhelks, *Nucella lapillus* (L.) suffering from imposex. *Marine Pollution Bulletin*. **22**:331-333.
- Evans, S.M., S.T. Hawkins, J. Porter, A.M. Samosir. 1994. Recovery of dogwhelk populations on the Isle of Cumbrae, Scotland following legislation limiting the use of TBT as an antifoulant. *Marine Pollution Bulletin*. **28**:15-17.
- Evans, S.M., T. Leksono and P.D. McKinnel. 1995. Tributyltin pollution: a diminishing problem following legislation limiting the use of TBT-based antifouling paints. *Marine Pollution Bulletin*. **30**(1):14-21.
- Evans, S.M., P.M. Evans and T. Leksono. 1996. Widespread recovery of dogwhelks, *Nucella lapillus* (L.) from Tributyltin contamination in the North Sea and Clyde Sea. *Marine Pollution Bulletin*. **32**(3):263-269.
- Evans, S.M. 1997. Assessments of Tributyltin Contamination from 1986 until 1997. The misues of imposex as a biological indicator of TBT pollution. *In: Harmful Effects of the Use of Antifouling Paints for Ships*. Stewen (ed). Organotin Environmental Programme Association (ORTEP Association). Witco GmbH, Germany. pp. 51-56.
- Evans, S.M. 1999a. Tributyltin pollution: the catastrophe that never happened. *Marine Pollution Bulletin*. **38**(8):629-636.
- Evans, S.M. 1999b. TBT or not TBT?: That is the question. *Biofouling*. **14**(2):117-129.
- Evans, S.M. 1999c. The environment: our joint responsibility. *Proceedings Oceans '99 International Symposium on the Treatment of Regulated Discharges from Shipyards and Drydocks*. Marine Technology Society. Washington, D.C. This Volume.
- Evans S.M., and R. Smith. 1999. The effects of regulating the use of TBT-based antifouling paints on TBT contamination. *Proceedings Oceans '99 International Symposium on the Treatment of Regulated Discharges from Shipyards and Drydocks*. Marine Technology Society. Washington, D.C. This Volume.
- Evans S.M. and G.J. Nicholson. 1999. Assessing the impact of antifouling compounds in the marine environment. Lessons to be learned from the use and misuse of biological indicators of TBT contamination. *Proceedings Oceans '99 International Symposium on the Treatment of Regulated Discharges from Shipyards and Drydocks*. Marine Technology Society. Washington, D.C. This Volume.
- Fox, T.J., T. Beacham, G.C. Schafran, and M.A. Champ. 1999. An advanced technology for removing TBT from shipyard wastewaters. *Proceedings Oceans '99 International Symposium on the Treatment of Regulated Discharges from Shipyards and Drydocks*. Marine Technology Society. Washington, D.C. This Volume.

- Garcia-Romero, B., T.L. Wade, G.C. Salata and J.M. Brooks. 1993. Butyltin concentrations in oysters from the Gulf of Mexico from 1989 to 1991. *Environmental Pollution*. 81:103-111.
- Gibbs, P.E. and G.W. Bryan. 1996a. Reproductive failure in the gastropod *Nucella lapillus* associated with imposex caused by tributyltin pollution: a review. In *Organotin, Environmental Fate and Effects* Champ and Seligman (eds). Chapman and Hall. London. pp. 259-280.
- Gibbs P.E. and G.W. Bryan. 1996b. TBT-induced imposex in neogastropod snails: masculinization to mass extinction. In: *Tributyltin: Case Study of an Environmental Contaminant*. de Mora (ed). Cambridge University Press. Cambridge. pp.. 212-236.
- Goldberg, E.D. 1992. Marine metal pollutants: a small set. *Marine Pollution Bulletin*. 25:45-7.
- Gollasch, S. 1999. Personal Communication, The Institute for Marine Studies in Kiel Germany. E-Mail: sgollasch@aol.com
- Hall, L.W. 1986. Monitoring organotin concentrations in Maryland waters of Chesapeake Bay. In: Interagency Workshop on Aquatic Monitoring and Analysis for Organotin. Published by NOAA/NMPPPO. Rockville, MD. pp. 27-28.
- Hall, L.W., M.J. Lenkevich, W.S.. Hall, A.E. Pinkney and S.J. Bushong. 1986. Monitoring organotin concentrations in Maryland waters of Chesapeake Bay. Proceedings Oceans '86 Organotin Symposium. Marine Technology Society. Washington, D.C. Vol. 4:1275-1279.
- Hall, L.W., Jr., M.J. Lenkevich, W.S. Hall, A.E.. Pinkney and S.J. Bushong. 1987. Evaluation of butyltin compounds in Maryland waters of Chesapeake Bay. *Marine Pollution Bulletin*. 18:78-83.
- Hall, L.W. Jr., 1988 Tributyltin environmental studies in Chesapeake Bay. *Marine Pollution Bulletin*. 19(9):431-438.
- Hartl, Mark G.J. 1999. Personal Communication. University of South Hampton. School of Ocean and Earth Science. Tel. (44) (1703-596-6271. E-Mail: hartl@soton.ac.uk.
- Huggett, R.J. 1986. Monitoring tributyltin in Southern Chesapeake Bay. In: The Proceedings of the Interagency Workshop on Aquatic Monitoring and Analysis for Organotin. Sponsored by NOAA/NMPPPO. Rockville, MD. pp. 29-30.
- Huggett, R.J. 1987. Statement for Senate Hearing. The effects of the chemical tributyltin (TBT) on the marine environment. Hearing Record. Senate Subcommittee on Environmental Protection of the Committee on Environment and Public Works. April 29. S. HGR 100-89. U.S. Gov. Print. Office. 73-832. Washington, DC. pp. 23-28 (oral) and pp. 68-74 (written).
- Huggett, R.J., M.A. Unger and D.J. Westbrook. 1986. Organotin concentrations in southern Chesapeake Bay. Proceedings Oceans '86 Organotin Symposium. Marine Technology Society. Washington, D.C. Vol. 4:1262-1265.
- Huggett, R.J., M.A. Unger, P.F. Seligman and A.O. Valkirs. 1992. The marine biocide tributyltin. *Environmental Science and Technology*. 26(2):232-237.
- Huggett, R.J., D.A. Evans, W.G. MacIntyre, M.A. Unger, P.F. Seligman and L.W. Hall. 1996. Tributyltin concentration in waters of the Chesapeake Bay. In: *Organotin: Environmental Fate and Effects*. Champ and Seligman (eds). Chapman & Hall. London. pp.485-502.
- Kram, M.L., P.M. Stang and P.F. Seligman. 1989. Adsorption and desorption of tributyltin in sediments of San Diego Bay and Pearl Harbor. *Appl. Organomet. Chem.* 3, 523-536.
- Keeley, K. L. 1999. Personal Communication. U.S. EPA Region 10 1200 Sixth Avenue. Seattle Washington. 98101. E-Mail: keeley.karen@epa.gov
- Langston, W.J. and G.R. Burt. 1991. Bioavailability and effects of sediment-bound TBT in deposit-feeding clams. *Scrobicularia plana*. *Marine Environmental Research*. 32:61-77.
- Laughlin, R.B. 1996. Bioaccumulation of TBT by aquatic organisms. In *Organotin: Environmental Fate and Effects* (Champ and Seligman, Eds). Chapman and Hall, Oxford. Chapter 16. pp. 331-355.

- Lewis, A.G. and W.R. Cave. 1982. The biological importance of copper in oceans and estuaries. *Oceanography and Marine Biology Annual Reviews*. **20**:471-695.
- MacLellan, D., M.S. Brancato, D. DeForest and J. Volosin. 1999. An evaluation of risks to U.S. Pacific Coast otters exposed to Tributyltin. Proceedings Oceans '99 International Symposium on the Treatment of Regulated Discharges from Shipyards and Drydocks. Marine Technology Society. Washington, D.C. This Volume.
- McCarty, L.S., 1991. Toxicant Body Residues: Implications for Aquatic Bioassays With Some Organic Chemicals. *In: Aquatic Toxicology and Risk Assessment* (Mayes and Barron, Eds). American Society for Testing and Materials. Philadelphia. pp. 183-192.
- McCarty, L.S., and D. Mackay. 1993. Enhancing Ecotoxicological Modeling and Assessment. *Environmental Science and Technology*. **27**(9):1719-1728.
- Meador, J.P. 1997. Comparative toxicokinetics of tributyltin in five marine species and its utility in predicting bioaccumulation and acute toxicity. *Aquatic Toxicology*. **37**:307-326.
- Meador, J.P. 2000. Predicting the fate and effects of tributyltin in marine systems. *Reviews of Environmental Contamination and Toxicology*.
- Meador, J. P. and C.A. Rice. (In Press). Impaired growth in the polychaete *Armandia brevis* exposed to tributyltin in sediment. *Marine Environmental Research*.
- Mikami, M. 1999. Personal Communication. Kansai Paint (America), Inc. Two Executive Drive, Suite 785. Fort Lee, NJ 02024. E-Mail: mmikami@kpamerica.com
- Minchin, D., C.B. Duggan and W. King. 1987. Possible effects of organotins on scallop recruitment. *Marine Pollution Bulletin*. **18**(11):604-608.
- Minchin, D. 1995 Recovery of a population of the flame shell, *Lima hians*, in an Irish bay previously contaminated with TBT. *Environmental Pollution*. **90**: 259-262.
- Minchin, D., J. Oehlmann, C.B. Duggan, E. Stroben and M. Keatinge. 1995. Marine TBT antifouling contamination in Ireland, following legislation in 1987. *Marine Pollution Bulletin*, **30**:633-639.
- Minchin, D. and J. Sheehan. 1999. The significance of ballast water in the introduction of exotic marine organisms to Cork Harbor, Ireland. ICES Coop. Res. Rep. No. 224. pp 12-24
- Minchin, D. 1999. Personal Communication. Fisheries Research Centre, Department of the Marine, Abbotstown, Dublin 15, Ireland. dminchin@frc.ie
- Nicholson, C.J., S.M. Evans, N. Palmer and R. Smith. 1998. The value of imposex in the dogwhelk *Nucella lapillus* and the common whelk *Buccinum undatum* as indicators of TBT contamination. *Invertebrate Reproduction and Development*. **34**:289-300.
- ORTEPA (Organotin Environmental Programme Association). 1996. The present status of TBT-copolymer antifouling paints. Proceedings of an International One Day Symposium on Antifouling Paints for Ocean Going Vessels. 21 February 1996. The Hague. The Netherlands.
- ORTEPA (Organotin Environmental Programme Association). 1997. Harmful Effects of the Use of Antifouling Paints for Ships. Stewen (ed). Organotin Environmental Programme Association (ORTEP Association). Witco GmbH. Germany. 187p.
- ORTEPA (Organotin Environmental Programme Association). 1998. Further updates on the toxicology of tributyltin, including assessments of risks to humans, wildlife and aquatic life. Stewen (ed). Organotin Environmental Programme Association (ORTEP Association). Witco GmbH. Germany. 181p.
- Reise, K., S. Gollasch and W.J. Wolff. 1999. Introduced marine species of the North Sea coasts. *Helgolander Meeresunters*. **52**:219-234.
- Rilov, G., Y. Benayahu, S.M. Evans and A. Gasith. 1999. Unregulated use of TBT-based antifouling paints and TBT pollution in Israel. *Marine Ecology Progress Series*. (In press).
- Ritsema, R. T. de Samle, L. Loens, A.S. de Jong and O.F.X. Donard. 1998. Determination of butyltins in harbour sediment and water by aqueous phase ethylation GC-ICF-MS and hydride generation GC-AAS. *Environmental Pollution*. **99**:271-277.
- Rouhi, A.M. 1998. The Squeeze on Tributyltins. C&E News. American Chemical Society, Washington, D.C. April 27. pp. 41-42.

- Russell, D., M.S. Brancato and H.J. Bennett. 1996. Comparison of trends in tributyltin concentrations among three monitoring programs in the United States. *Journal of Marine Science and Technology*. **1**:230-238.
- Salazar, M.H. 1986. Environmental significance and interpretation of organotin bioassays. In: Proceedings, Oceans 1986 Conference, 23-25 September 1986, Washington, D. C., Organotin Symposium, Vol. 4, pp. 1240-1244.
- Salazar, M.H. 1989. Mortality, growth and bioaccumulation in mussels exposed to TBT: Differences between the laboratory and the field. Proceedings, Oceans 1989 International Organotin Symposium. Marine Technology Society. Washington, D.C. Vol. 2. pp. 530-536.
- Salazar, M.H. 1999. Personal Communication. Applied Biomonitoring. 11648 72nd Place, NE, Kirkland, WA 98034. Tel. (425) 823-3905, Fax (425) 814-4998, msalazar@cnw.com
- Salazar, M.H. and S.M. Salazar. 1987. TBT effects on juvenile bivalve growth. SETAC Eighth Annual Meeting, 9-12 November 1987, Pensacola, Florida. Abstract Only (#330).
- Salazar, M.H. and M.A. Champ. 1988. Tributyltin and water quality: a question of environmental significance. Published in the Proceedings of the National Organotin. Marine Technology Society. Washington, D.C., and the IEEE Service Center. 445 Hoes Lane. Piscataway, N.J. 08854. U.S.A. Vol. 4. pp 1497-1506.
- Salazar M.H. and S.M. Salazar. 1991. Assessing site-specific effects of TBT contamination with mussel growth rates. *Marine Environmental Research*. **32**(1-4):131-150.
- Salazar, M.H. and S.M. Salazar. 1996. Mussels as bioindicators: effects of TBT on survival, bioaccumulation, and growth under natural conditions. In: *Organotin: Environmental Fate and Effects*. Champ and Seligman (Eds). Chapman & Hall. London. pp. 305-330.
- Salazar M.H. and S.M. Salazar. 1998. Using caged bivalves as part of an exposure-dose-response triad to support and integrated risk assessment strategy. In: *Ecological Risk Assessment: A Meeting of Policy and Science*. De Peyster and Day (Eds). SETAC Press. pp 167-192.
- Salazar, M.H. and S.M. Salazar. 1999a. Characterizing exposure and effects of TBT in bivalves using tissue chemistry and sublethal endpoints. Proceedings, Puget Sound Sediment Management Annual Review Meeting, Lacey, WA. April 1999, 12 pp.
http://www.nws.usace.army.mil/dmmo/TBT_EXPPDF
- Salazar, M.H. and S.M. Salazar. 1999b. Using the exposure-dose-response triad in laboratory and field bioassays: Lessons learned from caged bivalves and TBT. 20th Annual SETAC Meeting, Philadelphia, Pennsylvania. 14-18 November 1999 (platform presentation).
- Salazar, M.H. and S.M. Salazar. (In preparation). Lessons learned from caged bivalves and TBT.
- Salazar, M.H. 1999. Personal Communication. Applied Biomonitoring. 11648 72nd Place, NE, Kirkland, WA 98034. Tel. (425) 823-3905, Fax (425) 814-4998, msalazar@cnw.com
- Seligman, P. F., J. G. Grovhoug, A. O. Valkirs, P. M. Stang, R. Fransham, M. O. Stallard, B. Davidson and R. F. Lee. 1989. Distribution and fate of tributyltin in the United States marine environment. *Appl. Organomet. Chem.* **3**, 31-47.
- Seligman, P.F., J.G. Grovhoug, R.L. Fransham, B. Davidson, A.O. Valkirs. 1990. U.S. Navy Statutory Monitoring of Tributyltin in Selected U.S. Harbors. Annual Report: 1989. Naval Ocean Systems Center Technical Report No. 1346. Naval Ocean Systems Center, San Diego, CA. 32p.
- Seligman, P.F., C.M. Adema, J.Grovhoug, R.L. Fransham, A.O Valkirs, M.O. Stallard and P.M. Stang. 1996. Environmental loading of tributyltin from drydocks and ship hulls. In: *Organotin: Environmental Fate and Effects*. Champ and Seligman (Eds). Chapman & Hall. London. pp.405-428.
- Seligman, P.F. and A. Zirino (Eds). 1998. Chemistry, Toxicity, and Bioavailability of Copper and Its Relationship to Regulation in the marine Environment. Office of Naval Research Workshop Report, Technical Document No. 3044. U.S. Navy. SPAWAR Systems Center, San Diego. 51p.
- Svavarsson, J. and H. Skarphedinsdottir. 1995. Imposex in the dogwhelk *Nucella lapillus* (L.) in Icelandic waters. *Sarsia*. **80**, 35-40.
- Tester, M. and D.V. Ellis. 1995. TBT controls and the recovery of whelks from imposex. *Marine Pollution Bulletin*. **30**:90-91.

- Tester, M., D.V. Ellis and J.A.J. Thompson. 1996. Neogastropod imposex for monitoring recovery from marine TBT contamination. *Environmental Toxicology and Chemistry*. **15**:560-567.
- Toll, J., M.S. Brancato and D. DeForest. 1999. Regulating biocidal antifoulants: creating a level playing field. Proceedings Oceans '99 International Symposium on the Treatment of Regulated Discharges from Shipyards and Drydocks. Marine Technology Society. Washington, D.C. This Volume.
- U.S. EPA (Environmental Protection Agency), Chesapeake Bay Program. 1987 Survey of tributyltin and dibutyltin concentrations at selected harbors in Chesapeake Bay - Final Report. CBP/TRS 14/87. Annapolis, MD. 58p. + Appendix 40p.
- U.S. EPA (Environmental Protection Agency) 1991. Report to Congress on Environmental Monitoring of Organotin. OPTS (Office of Pesticides and Toxic Substances). Office of Pesticide Programs. Washington, D.C. 23p.
- U.S. EPA (Environmental Protection Agency). 1996a. Recommendations for screening values for tributyltin in sediments at Superfund sites in Puget Sound, Washington. Technical Report. EPA 910-R-96-014. Region 10. Seattle, Washington.
- U.S. EPA (Environmental Protection Agency) 1996b. Report to Congress on Alternatives to Organotin Antifoulants and Alternative Antifoulant Research. Draft: December, 1996. EPA Office of Pesticide Programs. Special Review and Registration Division (7508W) 401 M Street, SW. Washington, DC 20460. 35p.
- U.S. EPA. 1999. Technical Memorandum: Topics related to the tributyltin study at the Harbor Island Superfund Site Waster Sediment Operable Unit. U.S. EPA Region 10. Seattle, WA. 15p.
- U.S. Navy. 1997. Navy Program to Monitor Ecological Effects of Organotin. A Report to Congress. Prepared by P.S. Seligman of Marine Environmental Support Office and Jill Bloom of the EPA Office of Prevention, Pesticides and Toxic Substances and EPA Office of Water. Sept. 1, 1997. (Commonly Referred to as the Navy Risk Assessment for TBT). 76p.
- Valkirs, A.O., B. Davidson, L.L. Kear, R.L. Fransham, J.G. Grovhoug, and P.F. Seligman. 1991. Long-term monitoring of Tributyltin in San Diego Bay California. *Marine Environmental Research*. **32**:151-167.
- Wade, T.E., B. Garcia-Romero and J.M. Brooks. 1991. Oysters as biomonitors of butyltins in the Gulf of Mexico. *Marine Environmental Research*. **32**:233-241.
- Waite, M.E., M.J. Waldock, J.E. Thain, D.J. Smith and S. M. Milton. 1991. Reductions in TBT concentrations in UK estuaries following legislation in 1986 and 1987. *Marine Environmental Research*. **32**:89-111.
- Waite, M.E., J.E. Thain, M.J. Waldock, J.J. Cleary, A.R.D. Stebbing and R. Abel. 1996. Changes in concentrations of organotins in water and sediment in England and Wales following legislation. Chapter 27. *In: Organotin: Environmental Fate and Effects*. Champ and Seligman (eds). Chapman & Hall. London. pp. 553-580.
- Waldock, M.J. Thain, J.E. and M.E. Waite. 1987. The distribution and potential toxic effects of TBT in UK estuaries during 1986. *Applied Organometallic Chemistry*. **1**:287-301.
- Waldock, M.J., M.E. Waite and J.E. Thain. 1988. Inputs of TBT to the marine environment from shipping activity in the U.K. *Environmental Technology Letters*. **9**:999-1010.
- Weston. 1994. Harbor Island remedial investigation report. Prepared for U.S. Environmental Protection Agency. Region 10. Seattle, Washington. Roy F. Weston, Inc. Seattle, WA.
- White, H.H. and M.A. Champ. 1983. The great bioassay hoax and alternatives. *In: Hazardous and Industrial solid Waste Testing*. Amer. Soc. of Testing and Materials. ASTM-STP-805. pp. 299-312.
- Widdows, J., K.A. Burns, N.R. Menon, D.S. Page and S. Soria. 1990. Measurement of physiological energetics (scope for growth) and chemical contaminants in mussels (*Arca zebra*) transplanted along a pollution gradient in Bermuda. *Journal Experimental Marine Biology and Eecology*. **138**(1,2):99-117.

Cost Analysis of TBT Self-Polishing Copolymer Paints and Tin-Free Alternatives For Use On Deep-Sea Vessels

Nimmi Damodaran¹, John Toll², Mike Pendleton¹, Conrad Mulligan¹, David DeForest², Michael Kluck², Mary Sue Brancato² and John Felmy¹

ABSTRACT

Despite the success of current restrictions on reducing tributyltin (TBT) and its environmental effects, a total ban on TBT for marine antifouling paints is gaining international momentum. The economic impacts of such a ban will be borne almost entirely by operators of deep-sea ships trading globally. These parties might be doubly affected if tin-free alternatives are found to be less effective in preventing fouling than TBT paints, and equally or more detrimental to the environment. We have conducted a comparative analysis of the costs of using TBT self-polishing copolymer (SPC) antifouling paints and their alternatives, to better understand the exact nature and sources of the economic impact on the operators of deep-sea vessels. This analysis included the costs of antifouling paint, dry-docking rates, clean hull fuel consumption, and fuel consumption penalties as a result of hull fouling.

Our analysis indicates that TBT SPC paints offer significant cost savings to shipowners and operators, because their five-year painting interval reduces dry-docking costs and revenues lost while the ship is in dry-dock. Tin-free antifouling paints cannot, at present, match the five-year painting interval TBT SPC paints can offer shipowners and operators. In a survey of shipping companies operating deep-sea vessels, we found that nine of eleven that use TBT paints operate on a five-year dry-docking and painting interval, whereas eight of eight that use tin-free paints dry-dock and paint

on a 30-month cycle. The TBT painted ships operating on less than a five-year dry-docking interval generally did so because other maintenance needs necessitated more frequent dry-docking. Although tin-free SPCs require more frequent painting to maintain antifouling performance, their performance may be able to match TBT SPCs for the shorter painting interval (up to three years). Therefore, we have assumed no fuel penalty in comparing TBT SPCs and tin-free SPCs. Nonetheless, we found that tin-free SPCs are one to one-and-a-half times more expensive than TBT SPCs due to higher dry-docking costs, revenues lost, and paint costs. Furthermore, copper ablatives (as opposed to copper SPCs) are one-and-a-half to four times more expensive than TBT SPCs, due to fuel penalties, higher dry-docking costs, revenues lost, and paint costs. The ranges reflect the range of ship types and paint costs. The estimated annualized additional cost to the worldwide fleet of bulkers, container vessels, and very large crude carriers if a 30-month tin-free SPC is substituted for a 60-month TBT SPC is on the order of half a billion dollars. The penalty if a 30-month copper ablatives coating were substituted for the 60-month TBT SPC is approximately \$1 billion. These estimates incorporate the cost of coatings, dry docking costs, lost revenues, and a fuel penalty of four percent for copper ablatives. They do not include paint application costs, hull surface preparation costs, and waste disposal costs. They also assume no differences in fouling and hence no differences in fuel and other propulsion-related costs.

¹ Princeton Economic Research, Inc., 1700 Rockville Pike, Suite 550, Rockville, MD 20852

² Parametrix, Inc., 5808 Lake Washington Boulevard NE, Suite 200, Kirkland, WA 98033-7350

INTRODUCTION

Despite the success of the current restrictions at reducing tributyltin (TBT) and its effects in the environment, a total ban on TBT for marine antifouling paints seems increasingly likely. It has been suggested in the literature (Hunter 1997a) that a ban would be a political decision, rather than one based on consideration of economic costs and environmental benefits. The economic impacts of such a ban will be borne almost entirely by operators of deep-sea ships trading globally (Pidgeon 1993). The affected parties might be doubly affected if tin-free alternatives are found to be less effective than TBT antifouling paints, and equally or more detrimental to the environment.

A comparative analysis of the costs (direct and indirect) of TBT antifouling paints and their alternatives is necessary in order to understand the exact nature as well as the sources of the economic impact on the operators of deep-sea vessels. This paper provides such a cost analysis for TBT antifouling paints as well as some of the current tin-free alternatives for deep-sea vessels.

The existing literature does contain several cost studies of TBT and tin-free alternative antifouling paints. These indicate specific cost implications, such as increased fuel costs of \$50,000 to \$400,000 per year, depending on vessel size (Burnett 1995), and losses in revenues, due to additional dry-docking, of \$16,000 to \$50,000 a day (Lloyd's Shipping Economist 1998, Vassalos and Stergiopoulos 1992). Few studies have examined all the cost factors related to a total ban on TBT-based antifouling paints. One such study (Milne 1996) uses TBT as a paradigm case of environmental cost-benefit analysis, concludes that using TBT results in a total savings per year of almost four billion dollars U.S., and examines the implications on greenhouse gas and acid rain issues. Another study examines the effects of a European Union (EU) ban on TBT-based antifouling paints on the different sectors including TBT manufacturers, paint manufacturers, ship repair yards, and shipowners and operators (WS Atkins 1998). Several articles reference the early CEFIC (1992) study that examined cost savings from using TBT-based self-polishing copolymer (SPC) paints. This study examined fuel savings and savings due to extended dry-docking intervals, and arrived at annual savings

of three billion dollars. A recent submission (Ichikawa 1998) to the International Maritime Organization's Marine Environmental Protection Committee (MEPC) from the Japanese Ministry of Transport also includes a cost analysis, but it appears to contain some important gaps and questionable assumptions. The Japanese study compares costs for a Panamax carrier for TBT and tin-free coatings. It does not clarify whether the tin-free, copper-based alternative is an SPC or ablative coating and it does not specify whether lost revenues due to additional dry-docking have been considered. Additionally, fuel penalties are assumed to be 3 percent, when the literature suggests this number varies from 2 to 10 percent. This is an important assumption because it affects the operating costs and therefore the profit margins of ship operators.

Our study extends previous cost analyses by examining the implications to three types of deep-sea vessels of switching from a TBT SPC antifouling paint to tin-free alternatives. We have obtained costs directly from paint manufacturers, shipyards, government agencies, and other sources. This study advances the literature by synthesizing these varied estimates into scenarios, refining estimates of additional costs that will occur because of imposed changes in TBT usage. We have attempted to be transparent about the data used, and the basis for all assumptions we made in performing the cost analysis.

Tributyltin has been used as an antifoulant in marine paints since its commercial introduction in 1965. Tributyltin antifouling paint technologies have changed considerably over that period (Bennett 1996). Early TBT antifouling paints were based on free association and insoluble matrix technologies. In free association paints, TBT was physically mixed into a soluble matrix. Dissolution of the matrix released the biocide into the water. In insoluble matrix coatings, the biocide was leached from the coating into the water. The biggest problem with free association and insoluble matrix antifouling paints was that their biocide release rate declined over time. This meant that the release rate on freshly painted hulls had to exceed levels required to prevent fouling, in order for the paint to remain effective for a reasonable period of time.

Modern TBT SPCs are copolymer systems. The surface layer of TBT copolymer coatings is hydrolyzed to

release TBT at a slow, uniform rate over the life of the paint. As the TBT is released, the surface layer becomes weakened and is eroded as the vessel moves through the water, continually exposing a smooth, fresh paint surface layer. Thus, the modern TBT coatings provide a controlled, uniform release rate and a self-polishing finish, which improves fuel efficiency. The TBT SPC technology also allows thicker paint coats, doubling the lifetime of the coating compared to previous technologies.

Modern TBT antifouling paints are currently used on over 70 percent of the world's ocean-going fleet (CEFIC 1996). Tributyltin antifouling paints are highly effective fouling inhibitors, and contribute substantially toward a ship's fuel consumption efficiency. Present TBT antifouling paints have in-service lengths of five years or longer, allowing some vessel owner/operators to extend dry-docking intervals and consequently reduce dry-docking expenses.

Elevated surface water concentrations of TBT have been observed where vessel usage was high, specifically in marinas and harbors (Hall et al. 1987, Langston et al. 1987). In the 1980s, concern about TBT's impacts on non-target organisms¹ became a policy issue, following the publication of Alzieu et al. (1981) linking shell deformations in the Pacific oyster (*Crassostrea gigas*) to TBT in antifouling paints.² Field and laboratory studies in the mid- to late-1980s documented a relationship between TBT concentrations in water and the formation of shallow cavities in the inner calcareous shell layer of *C. gigas* (Stephenson et al. 1986, Davies et al. 1988, Valkirs et al. 1987), a phenomenon known as chambering. These studies were conducted under exposure regimens with TBT concentrations (150 to 1,890 ng/L) many times higher than mean environmental concentrations reported recently (1992 - 1996) in waters of the U.S. (generally < 10 ng/L) (Russell et al. 1996).

Shell thickening attributed to TBT led to the decline of *C. gigas* shellfisheries in Arcachon Bay, France, and

resulted in France banning the application of all antifouling paints to the hulls of non-aluminum boats shorter than 25 meters.³ The U.S. Congress passed the Organotin Antifouling Paint Control Act (OAPCA) in late 1988. This Act prohibited use of TBT-containing paints on ships under 25 m, with the exception of aluminum hulled vessels. It also limited TBT use to paints with laboratory-tested release rates not greater than 4 $\mu\text{g}/\text{cm}^2/\text{day}$. Similar restrictions were imposed in other nations. In most nations, the ban applies to vessels less than 25 meters in length, primarily affecting coastal vessels.

Legislation, where established, has been effective at controlling TBT levels in coastal environments. Monitoring data show reduction in TBT concentrations (Lange 1997, Batley 1996, Waite et al. 1991) and recovery of oyster fisheries (Stewart 1996). A critical review of current and future marine antifoulants was presented by the United Kingdom's delegation to the 35th session of the MEPC, held in March 1994 (Pidgeon 1993). MEPC 35 found that an extension of present TBT restrictions to a total ban was not justified on cost/benefit grounds, due to declining environmental risks and the absence of a satisfactory alternative to TBT. In the mean time, work on TBT alternatives has continued, particularly in Japan, where TBT antifouling paints are fully banned. A number of shipowners are painting their hulls with tin-free antifouling paints (Ichikawa 1998, Hunter 1997a). At least one paint company is now focusing its marketing efforts on the effectiveness of their tin-free antifouling paints (Hunter 1997b).

MATERIALS & METHODS

Our research yielded data sufficient to design and support a cost model using three ship classes widely found in the world fleet: a Panamax bulk carrier, a VLCC (Very Large Crude Carrier), and a container ship. The assumed characteristics of the three ships used in this study are based on ships in

¹ Non-target organisms are those aquatic organisms not settling on ship hulls.

² The lethal and sublethal effects of TBT on marine life have been studied extensively since the early 1980s. Alzieu (1996) provides a review.

³ Bosselmann (1996) provides a review of the history of environmental law concerning TBT in the environment.

current use. The steps in conducting the cost analysis include:

- identifying the alternative antifoulants;
- determining the dry-docking intervals for the different alternatives;
- determining the cost elements that are impacted by the alternatives;
- identifying data sources and collecting the data; and
- costing the alternatives.

Alternatives Considered

As a first step in the data collection process, we identified the range of commercially viable tin-free antifouling paints marketed for deep-sea vessels. These paints can be categorized by their chemical composition and mechanical properties. Tin-free ablative coatings are copper-based, and rely on physical processes to control the release of biocidal “boosters” mixed in the paint to increase antifouling effectiveness. The other primary category of tin-free alternatives are those based on SPC technologies; these encapsulate antifoulant boosters in chemical matrices similar in function to the SPC matrices found in modern organotin antifouling paints. These SPCs rely on chemical processes to release their antifoulants, providing a more uniform release rate over the life of the paint than copper ablatives. An additional benefit of SPCs is the self-polishing nature of the matrix. Properly applied, SPCs result in a nearly continuously smooth hull, reducing drag and associated bunker fuel consumption. Newer SPCs are based on copper acrylate and silicone functionalized methacrylate (silicone) technologies rather than organotin. This study does not include the silicone SPC, due to the reluctance of paint companies to provide the necessary cost data.

We have not examined paints containing naturally occurring antifouling compounds, or those that rely on low surface energy technologies. We

concur with most observers that these paints either have not reached technological maturity or are poorly suited for use on the vast majority of hull types found in the world’s deep-sea fleet. Low surface energy coatings are currently available and useful only for fast moving vessels such as some naval vessels, fast ferries and patrol boats. Since these coatings are not commercially available for all deep-sea vessels, this alternative is not considered in this study. Similarly, coatings with natural biocides are in developmental stages and therefore not considered here. Here we examine TBT SPC antifoulant coatings, and tin-free compositions that utilize either ablative or self-polishing mechanisms, and use a variety of biocide boosters.

Dry-Docking Intervals

We found no data indicating that tin-free antifouling paints can, at present, match the 60-month dry-docking interval TBT SPC paints can offer shipowners and operators. However, at least one paint company claims that alternative paints match the performance of their TBT SPC competitors at intervals of up to 36 months. The data we have obtained indicate that a paint’s performance is highly variable (based not only on physical application but also in-service maintenance, routes, operating profiles, etc.). Ships that are on a shorter dry-docking cycle appear to dry-dock every 32 months on average (Hunter 1997b). The recent submission to the International Maritime Organization by the Japanese Ministry of Transport (Ichikawa 1998) uses a 30-month dry-docking interval. The literature suggests that vessels might be dry-docking anywhere between 27 months and 60 month intervals (Aubert 1998, Hunter 1997a), and paint companies claim efficacies for 36 month and 60 month intervals (Hunter 1997b). The literature indicates that the 60-month interval is proven for TBT SPC coatings, whereas the non-TBT SPCs and the copper ablatives are effective for a maximum of 36 months (Hunter 1997a).

To verify some of this information, we conducted telephone and mail surveys of shipowners worldwide, and contacted Lloyd's Maritime Information Services (LMIS) for dry-docking information. The survey results showed that nine of eleven shipping companies that use TBT paints operate on a five-year dry-docking interval, whereas eight of eight that use tin-free paints dry-dock on a 30-month cycle. The TBT painted ships operating on less than a five-year dry-docking interval generally did so because other maintenance needs necessitated more frequent dry-docking. In-water survey information obtained from LMIS for 76 ship types with average lengths greater than 50m were reviewed. Vessels for which in-water surveys are conducted are likely on five-year dry-docking cycles rather than 30-month cycles. The LMIS data support our assumption of a five-year painting interval for TBT-painted ships.

In light of the data we have obtained, there appears to be a five-year dry-docking interval for TBT SPC-painted vessels. As a result, our analysis used a 60-month dry-docking interval for TBT SPCs and a 30-month dry-docking interval for tin-free coatings.⁴

Cost Elements

As often voiced in submissions to the MEPC and in the trades press, the debate surrounding any ban on the use of organotin-containing antifoulants centers on the issue of cost. Examination of previous cost analyses (Ichikawa 1998, Milne 1996) provided two analyses with radically different aims and outcomes. With limited guidance to draw from these studies, we undertook a regimen of questioning industry insiders to

ascertain the types of data required for determining the costs of applying one antifouling paint versus another. These inquiries yielded the following relevant cost elements, upon which our cost model is built:

- antifouling paint costs,
- dry-docking rates,
- clean hull fuel consumption, and
- fuel consumption penalties as a result of hull fouling.

Modeling assumptions are discussed in a following section.

Data Collection Methodology

We relied heavily on personal interviews with industry representatives and a thorough literature review. Individuals representing paint manufacturers, shipyards, shipping companies, the United States Navy, the U.S. Department of Transportation Maritime Administration (MARAD), LMIS, and maritime trade associations, among others, were contacted and asked to provide insights and data to populate the cost model. Surveys were developed to obtain information from paint manufacturers, shipping companies, and shipyards worldwide (Damodaran et al. 1998). The literature review was conducted in the libraries of the International Maritime Organization in London and the Department of Transportation library in Washington, D.C. It included a thorough examination of trade publications, publicly available reference materials, specialized reports on segments of the maritime industry, and government publications and reports. Data on ship dry-docking schedules and ship condition surveys were obtained in a database format from LMIS.

⁴ U.S. ships are required by law to dry-dock every 30 months. The U.S. Maritime Administration (MARAD 1997) reports that of the world's 26,764 ocean-going merchant ships (greater than or equal to 1,000 gross tons), 498 (1.86 percent) are U.S. ships.

RESULTS & DISCUSSION

As discussed in the methodology section above, we utilized a two-pronged approach of primary and secondary (i.e., literature review) data collection. Our primary data collection included discussions with government agencies, associations, and industry contacts. Government agencies, particularly MARAD, provided statistics on the shipping industry and world fleet. In addition, several individuals at MARAD provided insight regarding dry-docking procedures in general, and in particular with regard to the application of antifouling paints. The various associations we contacted provided little more than anecdotal information.

Our efforts to collect data from industry sources included contacting coatings manufacturers, ship repair yards (dockyards), ship maintenance subcontractors, and shipping companies/shipowners. The five paint companies that account for 80 percent of the market share were contacted for information on paint costs. Three companies that account for over 60 percent of the market share responded with useful data. Nine shipyards were contacted, with three providing useful information.

Four of the five contacts made in shipping information companies resulted in data and studies on shipping statistics. Of the eleven shipping owners and operators, only one responded with information associated with conversion from TBT to tin-free antifouling paints. It should be emphasized that time constraints prevented us

from following up on these contacts, or making additional contacts in this sector.

We have expressed all costs in 1997 U.S. dollars, and estimated costs for a container, a bulk carrier and a VLCC, which represent three major classes of deep-sea vessels. It was assumed that the life of a ship is 25 years and all costs are calculated over the life of the ship.

Paint Costs

The first category of costs examined was paint costs associated with the three types of ships. Paint costs were calculated based on information received from three paint companies. The paint companies typically provided unit costs as well as quantities required for the three types of vessels.

They were asked to quote prices for antifouling systems for the three representative ships (one container ship, one Panamax bulk carrier, and one VLCC). Paint costs from two paint companies were obtained in this manner. A third company quoted price ranges for three popular product lines, as well as providing estimated paint volumes required to paint 10,000 m². When asked about painting a larger hull area, this company suggested we “ramp up” from the given figure, which is what we have done. Because paint costs vary, we examined the overall costs based on both the minimum and the maximum paint cost associated with the different paint categories, as shown in Table 1.

Table 1. Minimum and maximum paint costs over a 25 year life (1997 US \$).

Ship type and paint costs	TBT SPC (60 months)	Copper SPC (30 months)	Copper ablative (30 months)
Container – minimum	644,086	1,040,346	438,649
Container – maximum	733,104	1,377,180	1,368,995
Bulk carrier – minimum	308,178	835,934	223,694
Bulk carrier – maximum	642,308	1,052,834	717,447
VLCC – minimum	647,267	1,903,852	601,183
VLCC – maximum	722,732	2,022,378	2,093,503

VLCC = Very large crude carrier

When compared, it is clear that TBT SPCs are substantially less expensive than copper SPCs. Copper SPC paint costs vary from being 62 percent more expensive using the minimum cost paints for the container ship, to 194 percent more expensive for the VLCC using the minimum cost paints. Although the container ship is closer to a bulk carrier in size, paint manufacturers have typically indicated that container ships require more paint per square meter than the bulk carriers or the VLCCs. The faster speeds of these ships may be one reason for the increased quantities required.

The costs of paint application, including surface preparation, labor, and waste disposal, are necessary for a more complete picture of the costs. These costs, while likely a significant component in the decision to apply a given antifouling paint, are discounted in this study for several reasons.

Waste disposal costs are likely to be greatly impacted by the level of environmental regulation present in any given nation. The variability of the enforcement of these regulations, and the subsequent variations in waste disposal costs, make it very difficult to estimate these highly variable costs. Regarding hull surface preparation and application costs, the study team was hindered by the competitive nature of the ship repair industry, and individual yard's reticence to release proprietary information. Even market specialists such as Lloyds' Shipping Economist and Drewry's are unable to estimate or ascertain these costs.

While it is possible to overcome these obstacles and obtain the data, it was beyond the scope of this study to pursue this information.

Dry-Docking Costs

Dry-docking rates were obtained from one Japanese interest; these were confirmed as realistic, through comparison with figures in the literature, and incorporated into the cost model. A review of the literature indicated that the number

of days in dry-dock varied from estimates of four (and Stergiopoulos 1992) to 20 days (Kawai 1998) depending on the ship type and other factors such as required maintenance. This study assumes the lower end of the range for each of our ship types, as provided by the Japanese shipyard that provided dry-docking rates as well. The number of dry-docking days is assumed to be seven days for the bulk carrier and container ships, and 14 days for the VLCC. The rates were dependent on the gross tonnage of vessels and daily rates were calculated to be \$7,185 for the bulk carrier, \$9,786 for the container ship and \$14,424 for the VLCC.

Lost Revenue

The operators of the vessels experience a loss in revenue for every day that the ship is in dry-dock as opposed to being in operation. These daily revenues were estimated from the literature (Lloyd's Shipping Economist 1998). For the bulk carrier, the daily revenues were estimated to be \$16,000. Daily revenues for the container vessel and VLCC were \$19,175 and \$12,500, respectively.

Fuel Penalty

Tributyltin SPCs are widely considered the most effective commercially available antifoulants. Empirical evidence (Hunter 1997b) indicates that 96 percent of ships with TBT SPC coatings come to port in the 30 to 36 month dry-docking interval with satisfactory performance. The equivalent numbers for tin-free SPCs are 90 percent and about 70 percent for copper ablatives. The less effective an antifoulant, the more hull drag increases fuel consumption and fuel consumption costs. In the process of evaluating competing performance claims, we have relied heavily on industry and trades sources. International Paints claims its Ecoloflex tin-free SPC displays similar performance characteristics to its TBT SPC product line. Without access to proprietary data regarding same-ship performance, we are unable

to either confirm or refute this claim. Thus, we assume International Paint's performance claims vis-à-vis the Ecoloflex product line to be accurate. Fuel penalties associated with the use of copper ablatives vary from two to 10 percent with 4 percent being most frequently cited. This study uses 4 percent as a fuel penalty for comparing costs across the categories of antifoulants. It also compares the copper ablatives to the 60-month TBT SPC system using a range of fuel penalty rates.

Costing the Alternatives

The costs of the alternatives were calculated for the three representative ships: a Panamax bulk carrier, a container ship, and a VLCC. The life of the vessels was assumed to be 25 years. The paint costs, dry-docking costs, lost revenues, and fuel penalties were calculated over the life of the vessels. The number of dry-dockings was estimated to be four using a 60-month TBT SPC system. The number of dry-dockings is nine using a 30-month interval for the copper SPC and the copper ablatives systems. It should be noted that fuel penalties were calculated only for the ablatives coatings. Because we used both the minimum and maximum paint costs, the comparative analysis was conducted for both costs for all three vessel types. In all cases the 60-month TBT SPC was used as a baseline against which the other systems were compared. The detailed tabular breakdown of costs is presented in Damodaran et al. (1998).

Figures 1 and 2 show the costs for the bulk carrier using maximum and minimum paint costs. The copper SPC system costs 95 percent more than the 60-month TBT system using the maximum paint costs and is 140 percent more expensive when using the minimum paint costs. The ablatives are much more expensive; using the maximum paint costs for a 60-month TBT SPC system results in a 156 percent cost increase, and using the minimum paint costs results in a 193 percent cost increase.

Figures 3 and 4 show the costs for the container ship using maximum and minimum paint costs. The copper SPC system cost 107 percent more than the 60-month TBT system using the maximum paint costs and is 97 percent more expensive when using the minimum paint costs. The ablatives are much more expensive; the maximum paint costs result in a 401 percent increase and the minimum paint costs result in a 368 percent increase over using a 60-month TBT SPC system.

Figures 5 and 6 show the costs for the VLCC using maximum and minimum paint costs. The copper SPC system cost 143 percent more than the 60-month TBT system using the maximum paint costs and is roughly equivalent at 146 percent more expensive when using the minimum paint costs. Again, the ablatives are much more expensive. Using the maximum paint costs for a 60-month TBT SPC system results in a 250 percent cost increase and using the minimum paint costs results in a 193 percent increase.

Sensitivity Analysis of Fuel Penalties

Numerous studies claim various "penalties" with regard to fuel consumption for ships that use copper ablatives antifoulants as opposed to TBT SPC coatings. In our study, we have assumed a 4 percent fuel penalty, based on the 1992 IMO paper presented by CEFIC. In order to examine the importance the assumed fuel penalty plays in determining total costs of using ablatives instead of SPC coatings, we have graphed (Figures 7 and 8) the total costs given fuel penalties ranging from 2 to 10 percent for both maximum and minimum paint cost assumptions. In the case of the VLCC, a fuel penalty of 10 percent almost doubles the total costs relative to a 2 percent penalty. For a bulk carrier ship, a doubling is apparent. For the container ship, there is a tripling in costs when these fuel penalty extremes are considered. Container ships are particularly sensitive to fuel penalties because they run at faster speeds than

bulkers and crude carriers. It is important to note that the total costs shown here do not represent all the operating costs that must be considered; for example, labor cost at dockyards, surface preparation of the hulls, and waste disposal costs are not considered in this analysis. Including these further increases the costs of tin-free alternative antifouling coatings.

Based on our review of the literature, our estimates of fuel consumption differences as a function of antifoulant type seem reasonable. For example, in our study, a hypothetical VLCC painted with a copper ablative coating requires \$92,000/year

more for fuel than if it was coated with an SPC. Lanz (1995) considered a larger tanker, and estimated that this difference is \$100,000 annually. A ship with moderate green weed fouling typically consumes 10 percent more fuel than a similar vessel with a smooth hull. For a 40,000 dead weight tonnage (dwt) bulk carrier this would result in an extra \$72,000 in fuel bills per year (based on \$100/ton fuel costs, 30 tons/day and 240 days at sea). Under a 10 percent fuel penalty assumption, fuel costs for our larger bulk carrier (54,000 dwt) would be \$112,000. Table 2 shows the increased costs associated with a variety of fuel penalty rates.

FIGURE 1

	PAINT COST	DRYDOCK COSTS	LOST REVENUES	FUEL PENALTY
TBT SPC	\$642,308	\$201,170	\$448,000	
COPPER SPC	\$1,052,834	\$452,633	\$1,008,000	
COPPERABLATIVE	\$717,447	\$452,633	\$1,008,000	\$1,124,565

FIGURE 2

	TBT SPC	COPPER SPC	COPPERABLATIVE	
PAINT COST	\$308,178	\$835,934	\$223,694	
DRYDOCK COSTS	\$201,170	\$452,633	\$452,633	
LOST REVENUES	\$448,000	\$1,008,000	\$1,008,000	
FUEL PENALTY				\$1,124,565

FIGURE 3

	TBT SPC	COPPER SPC	COPPERABLATIVE	
PAINT COST	\$733,104	\$1,377,180	\$1,368,995	
DRYDOCK COSTS	\$274,021	\$616,547	\$616,547	
LOST REVENUES	\$536,900	\$1,208,025	\$1,208,025	
FUEL PENALTY				\$4,548,960

FIGURE 4

	TBT SPC	COPPER SPC	COPPERABLATIVE	
PAINT COST	\$644,086	\$1,040,346	\$438,649	
DRYDOCK COSTS	\$274,021	\$616,547	\$616,547	
LOST REVENUES	\$536,900	\$1,208,025	\$1,208,025	
FUEL PENALTY				\$4,548,960

FIGURE 5

	TBT SPC	COPPER SPC	COPPERABLATIVE	
PAINT COST	\$722,732	\$2,022,378	\$2,093,503	
DRYDOCK COSTS	\$807,737	\$1,817,409	\$1,817,409	
LOST REVENUES	\$700,000	\$1,575,000	\$1,575,000	
FUEL PENALTY				\$2,324,205

FIGURE 6

	TBT SPC	COPPER SPC	COPPER ABLATIVE	
PAINT COST	\$647,267	\$1,903,852	\$601,183	
DRYDOCK COSTS	\$807,737	\$1,817,409	\$1,817,409	
LOST REVENUES	\$700,000	\$1,575,000	\$1,575,000	
FUEL PENALTY				\$2,324,205

FIGURE 7(MAX)

BULKER	CONTAINER	VLCC
\$2,740,363	\$5,468,047	\$6,648,015
\$3,021,504	\$6,605,287	\$7,229,066
\$3,302,645	\$7,742,527	\$7,810,118
\$3,583,786	\$8,879,767	\$8,391,169
\$4,146,069	\$11,154,247	\$9,553,271
10\$4,989,493	\$14,565,967	\$11,296,425

FIGURE 8 (MIN)

BULKER	CONTAINER	VLCC
\$2,246,610	\$4,537,701	\$5,155,694
\$2,527,751	\$5,674,941	\$5,736,746
\$2,808,892	\$6,812,181	\$6,317,797
\$3,090,033	\$7,949,421	\$6,898,848
\$3,652,316	\$10,223,901	\$8,060,951
10\$4,495,740	\$13,635,621	\$9,804,104

PANAMAX BULK CARRIER (BASED ON MAXIMUM PAINTS COSTS)**FIGURE 1.**

ESTIMATED LIFETIME COSTS FOR A SINGLE PANAMAX BULK CARRIER, ASSUMING MAXIMUM PAINT COSTS.

PANAMAX BULK CARRIER (BASED ON MINIMUM PAINTS COSTS)**FIGURE 2.**

ESTIMATED LIFETIME COSTS FOR A SINGLE PANAMAX BULK CARRIER, ASSUMING MINIMUM PAINT COSTS.

CONTAINER SHIP (BASED ON MAXIMUM PAINT COSTS)

Table 2. Cost comparison of copper ablative and TBT SPC as a function of fuel penalty (percentage increase over the costs of a 60-month TBT SPC).

% Fuel Penalty	Bulkер		Container		VLCC	
	Max	Min	Max	Min	Max	Min
2	112	135	254	212	198	139
3	134	164	328	290	224	166
4	156	193	401	368	250	193
5	177	223	475	446	276	220
7	221	282	622	603	328	274
10	286	370	843	837	406	355

Costs to the Worldwide Deep-Sea Shipping Fleet

In addition to calculating costs for individual vessels, we have estimated the costs to the world fleet of bulkers, container vessels, and VLCCs, which together comprise 75 percent of the world fleet deadweight tonnage. Our estimates incorporate the cost of coatings, dry-docking costs, lost revenues, and a fuel penalty of 4 percent. They do not include paint application costs, hull surface preparation costs and waste disposal costs. Maximum and minimum paint costs bound the range of antifouling coating costs quoted by

manufacturers. The differential highlights the difference between the TBT SPC and its alternatives. The cost difference between the copper SPC system and the TBT SPC is approximately \$500 million (Table 3), and that for the copper ablative system versus the TBT SPC approximately \$1 billion (Table 4). These cost difference estimates probably are biased low because the tin-free paints require more frequent dry-docking, and therefore, are expected to have higher paint application, hull preparation, and waste disposal costs.

Table 3. Estimates of the costs of using a 30-month copper SPC antifouling system relative to a 60-month TBT SPC system on bulker, container and VLCC ships worldwide.

Ship Type	Annual Lifecycle Cost Differential (\$)ª	Dead-Weight Tonnage	\$/Dead Weight Tonª	Millions of Dead Weight Tons (Worldwide)	Financial Impact on World Fleetª
Bulker ^b	48,880/53,569	54,500	0.90/0.98	239.2	214.5/235.1
Container	66,309/56,396	30,825	2.15/1.83	48.6	104.5/88.9
VLCC	127,373/125,650	137,684	0.93/0.91	270.3	250.1/246.7
Total	-	-	-	-	569.1/570.7

^a Based on maximum/minimum paint costs.

^b The bulker's annual lifecycle cost differential is higher for the minimum coatings cost than for the maximum coatings cost because the difference between the minimum copper SPC and TBT SPC paint costs is greater than the difference between the maximum copper SPC and TBT SPC paint costs.

Table 4. Estimates of the costs of using a 30-month copper ablative antifouling system relative to a 60-month TBT SPC system on bulker, container and VLCC ships worldwide.

Ship Type	Annual Lifecycle Cost Differential ^a	Dead-Weight Tonnage	\$/Dead Weight Ton ^a	Millions of Dead Weight Tons (Worldwide)	Financial Impact on World Fleet ^a
Bulker	80,447/74,062	54,500	1.48/1.36	239.2	353.1/325.1
Container	247,940/214,287	30,825	8.04/6.95	48.6	390.9/337.9
VLCC	223,186/166,512	137,684	1.62/1.21	270.3	438.2/326.9
Total	-	-	-	-	1,182.1/989.8

^a Based on maximum/minimum paint costs.

CONCLUSIONS AND RECOMMENDATIONS

We have undertaken a comparative analysis of the costs (direct and indirect) of TBT SPC antifouling paints and their alternatives, in order to understand the nature and sources of the economic impact on the operators of deep-sea vessels. Additionally, we have examined what is known about the environmental fate and effects of tin-free alternative antifouling paints. We have drawn five general conclusions, presented below.

1. Tributyltin SPC paints offer significant cost savings to shipowners and operators because their five-year dry-docking interval reduces dry-docking costs and revenues lost while the ship is in dry-dock for cleaning and repainting. We found no data indicating that tin-free antifouling paints can, at present, match the five-year dry-docking interval TBT SPC paints can offer shipowners and operators.
2. There are claims that alternative paints match the performance of their TBT SPC competitors at intervals of up to three years. Therefore, we have assumed no fuel penalty in comparing TBT SPCs and copper SPCs. Nonetheless, we found the copper SPCs are 95 - 146 percent more expensive than the TBT SPC due to higher dry-docking costs, revenues lost, and paint costs. Copper ablatives were 156 percent - 401 percent more expensive than TBT SPCs, due to fuel penalties, higher dry-docking costs, revenues lost, and paint costs. The
3. The estimated penalty to the worldwide fleet of bulkers, container vessels, and VLCCs when copper SPC is substituted for a TBT SPC is on the order of \$500 million. When a copper ablative coating is substituted for the TBT SPC, the penalty is approximately \$1 billion. These estimates incorporate the cost of coatings, dry docking costs, lost revenues, and a fuel penalty of 4 percent for the copper ablative paint. They do not include paint application costs, hull surface preparation costs and waste disposal costs, and these costs would approximately double for the shorter dry-docking interval. The literature indicates that the fuel penalty for copper ablatives may be as high as 10 percent, in which case the \$1 billion annual cost differential would be an underestimate.
4. We have qualitatively assessed the effect of a worldwide TBT ban on five different sectors: tributyltin oxide (TBTO) producers, paint companies, dry docks/repair yards, shipowners/operators, and the environment. Our results indicate paint companies are positioned to capture a windfall if TBT is banned, and that owners/operators, and ultimately consumers, stand to lose. The impact on dry docks/repair yards would depend on how a TBT ban was enforced; if enforcement is uniform it could mean a windfall, if not it could simply mean work shifting to locations where enforcement is lax.

ranges reflect the range of ship types considered in the analysis and uncertainty about paint costs.

5. The final sector in our analysis is the environment. The data we have acquired indicate that TBT and copper SPCs provide the same fuel efficiency, so the environmental risks or benefits of switching from a TBT SPC to a copper SPC would have to do primarily with the pesticidal impacts on non-target organisms. We have not found extant data or analyses sufficient to quantitatively compare the risks of tin-free antifouling paints to TBT. Critical data gaps include chronic toxicity data for biocide boosters, and estimates of environmental concentrations for some of the boosters. However, the data on SeaNine-211 and Irgarol 1051 indicate that paints containing either of these biocides do pose risks to the environment. Based on the data currently available on TBT and tin-free antifouling paints, none of the tin-free alternative antifouling paints have been shown to be as safe as or safer for the environment than TBT SPC paints, for use on deep-sea vessels.

REFERENCES CITED

- Alzieu, C., M. Héral, Y. Thibaud, M.J. Dardignac, and M. Feuillet. 1981. Influence des peintures antisalissures a base d'organostanniques sur la calcification de l'huitre - *Crassostrea gigas*. Revue des Travaux des Pêches maritimes, 45:100-116.
- Aubert, J.S., Hull surface treatment - performance, economy and the environment. Know How, No. 1, 1998. p. 10-14.
- Batley, G. 1996. The distribution and fate of tributyltin in the marine environment. Pages 139-166 in S.J. deMora, editor. Tributyltin: Case study of an environmental contaminant. Cambridge environmental chemistry series. No. 8, 139-166.
- Bennett, R.F. 1996. Industrial manufacture and applications of tributyltin compounds. Pages 21-61 in S.J. deMora, editor. Tributyltin: Case study of an environmental contaminant. Cambridge Environmental Chemistry Series. No. 8.
- Bosselman, K. 1996. Environmental law and tributyltin in the environment. Pages 237-263 in S.J. deMora, editor. Tributyltin: Case study of an environmental contaminant. Cambridge Environmental Chemistry Series. No. 8.
- Burnett, R. 1995. Solving the antifouling puzzle, Ship Repair and Conversion Technology, 3rd Quarter 1995.
- CEFIC, 1992. TBT copolymer antifouling paints: the facts. Submitted to the International Maritime Organization's Marine Environmental Protection Committee, July 24, 1992, MEPC 33/INF.14.
- CEFIC. 1996. Harmful effects of the use of antifouling paints for ships: A review of existing antifouling paints and the development of alternative systems. Submitted to the International Maritime Organization's Marine Environmental Protection Committee, May 3, 1996, MEPC 38/14/4.
- Damodaran, N., J.E. Toll, M. Pendleton, C. Mulligan, D. DeForest, M. Kluck and J. Felmy. 1998. "Cost-Benefit Analysis of TBT Self-Polishing Copolymer Paints and Tin-Free Alternatives for Use on Deep-Sea Vessels." Report to the CEFIC Organotin Environmental Programme.
- Davies, I.M., J. Drinkwater, and J.C. McKie. 1988. Effects of tributyltin compounds from antifoulants on Pacific oysters, *Crassostrea gigas* in Scottish Sea Lochs. Aquaculture, 74, 307-317.
- Hall, L.W., M.J. Lenkevich, W.S. Hall, A.E. Pikney, and S.J. Bushong. 1987. Evaluation of butyltin compounds in Maryland waters of Chesapeake Bay. Mar. Poll. Bull., 18, pp 78-83.
- Hunter, J.E. 1997a. Antifouling coatings and the global environmental debate, *PCE* November 1997.

- Hunter, J.E. 1997b. IMO discussions with the Marine Environment Protection Committee (MEPC) on harmful effects of the use of antifouling paints from ships including TBT.
- Ichikawa, Y. 1998. Alternatives for TBT antifouling ship bottom paints. Memo submitted by Japanese Ministry of Transport, Coordinator of International Regulations to the International Maritime Organization's Correspondence Group on the Reduction of Harmful Effects of the Use of Antifouling Paints for Shipping, February 9, 1998.
- Kawai, S. 1998. Kawasaki Heavy Industries, Personal communication, February 1998.
- Lange, R. 1997. Use of tributyltin compounds in antifouling paints : Update on the results of monitoring programmes in different parts of the world. Pages 11-18 in Harmful effects of the use of antifouling paints for ships: Tributyltin (TBT) antifouling paints. Submitted to the International Maritime Organization's Marine Environmental Protection Committee, December 1997, MEPC 41/10.
- Langston, W.J., G.R. Burt, and Ahou Mingjiang. 1987. Tin and organotin in water, sediments, and benthic organisms of Poole Harbour. Mar. Poll. Bull. 18, pp. 634-639.
- Lanz, R. 1995. Barnacle beating - an international issue. The Motor Ship. November, 1995. p. 47-48.
- Laughlin, Jr., R.B., R. Gustafson, and P. Pendoley. 1988. Chronic embryo-larval toxicity of tributyltin (TBT) to the hard shell clam *Mercenaria mercenaria*. Mar. Ecol. Prog. Ser. 48:29-36.
- Lloyd's Register Engineering Services. 1993. Critical review of current and future marine antifouling coatings, report for the Department of Transport, November 1993.
- Lloyd's Shipping Economist. 1998. 20(1).
- MARAD. 1997. MARAD '96 – The Annual Report of the Maritime Administration, U.S. Department of Transportation. May 1997.
- Milne, A. 1996. The costs and benefits of tributyltin and alternative antifoulants, *Proceedings of the International One Day Symposium on Antifouling Paints for Ocean-going Vessels*, The Hague, February 21, 1996.
- Pidgeon, J.D. 1993. Critical Review of Current & Future Marine Antifouling Coatings, 1993, research carried out for the U.K. Department of Transport and presented at The IMO, Marine Environment Protection Committee, 35th Session, London, 19 pages. (*Lloyd's Register Engineering Services, 29 Wellesley Road, Croydon Cro 2AJ, UK.).
- Russell, D., M.S. Brancato, and H.J. Bennett. 1996. Comparison of trends in tributyltin concentrations among three monitoring programs in the United States. J. Mar. Sci. Technol. 1, 230-238.
- Stephenson, M.D., D.R. Smith, J. Goetzl, G. Ichikawa, and M. Martin. 1986. Growth abnormalities in mussels and oysters from areas with high levels of tributyltin in San Diego Bay. In *Proceedings of the Organotin Symposium, Oceans '86 Conference*, Washington, Sept. 23-25, 1986, 4, 1246-1251.
- Stewart, C. 1996. The efficacy of legislation in controlling tributyltin in the marine environment. Pages 264-297 in S.J. deMora, editor. Tributyltin: Case study of an environmental contaminant. Cambridge environmental chemistry series. No. 8.
- Valkirs, A.O., B.M. Davidson, and P.F. Seligman. 1987. Sublethal growth effects and mortality to marine bivalves from long term exposure to tributyltin. Chemosphere, 16, 1, 201-220.
- Vassalos, D., and G. Stergiopoulos. 1992. A dry-docking and antifouling-free hull surface maintenance management system based on in-water surveys, *IMAS 92, Quality of Shipping in the Year 2000*, November 11-13, 1992.

Waite, M.E., M.J. Waldock, J.E. Thairn, D.J. Smith and S.M. Milton. 1991. Reductions in TBT concentrations in UK estuaries following legislation in 1986 and 1987. *Marine Environmental Research* 32:89-111.

W.S. Atkins International Ltd. 1998. Assessment of the effects of further restrictions on the marketing and use of tin organic compounds in antifouling paints. Final Report. European Commission Directorate General III.

Aquatic Ecological Risks Posed By Tributyltin in U.S. Surface Waters: PRE-1989-1996 Data¹

Rick D. Cardwell², Mary Sue Brancato, John Toll, And
David Deforest, Lucinda Tear
Parametrix, Inc., 5808 Lake Washington Boulevard N.E., Suite 200,
Kirkland, Washington 98033

ABSTRACT

Acute and chronic risks to aquatic life from exposure to tributyltin (TBT) in surface waters were assessed probabilistically using more than nine years of monitoring data. More than 50 sites around the United States were sampled, representing six saltwater regions and one freshwater (Lake Erie). Ambient TBT concentrations were compared to acute and chronic effect thresholds to estimate risks for each year (1986 - 1988, 1992 - 1996), site type, and region. Site types comprised commercial harbors, shipyards, marinas, and fish/shellfish habitats proximate to these commercial areas.

Tributyltin concentrations in surface waters have declined in all regions and site types since passage of the Organotin Antifouling Paint Control Act in 1988. No risks of acute toxicity have been suggested since 1994. Chronic risks have remained highest in marinas compared to other site types, but have declined from a risk involving 25 percent of the species prior to 1989 to one involving 6 percent of the species in 1996. Risks associated with commercial harbors and shipyards have been similar (4 - 6%) since 1994. Chronic risks have been ≤ 1 percent in fish and shellfish habitats sampled $< 1 - 2$ km from TBT sources. Risks in Galveston Bay, over all years, (1 - 19%) have been greater than in the other regions ($\leq 5\%$).

Keywords: Tributyltin, Risk assessment, Toxicity, Chronic, Acute

INTRODUCTION

Tributyltin (TBT) has been used as an antifoulant in marine paints since its commercial introduction in 1965 [1, 2]. Elevated surface water concentrations of TBT have been observed where vessel usage was high, specifically in marinas and harbors [3, 4]. Tributyltin exerts chronic effects on aquatic organisms at concentrations down to $\pm 10 - 20$ ng/L, and 10 ng/L has been proposed by the U.S. EPA as the chronic marine water quality criterion protective of at least 95 percent of aquatic organisms [5]. In the 1980s, concern about risks to non-target organisms prompted passage of the Organotin Antifouling Paint Control Act (OAPCA) by the U.S. Congress in late 1988. This Act restricted use of TBT-containing paints to ships over 25 m and those with aluminum hulls. It also limited TBT use to paints with laboratory-tested release rates of $\leq 4 \mu\text{g}/\text{cm}^2/\text{day}$. Subsequent to restrictions on TBT usage, environmental monitoring revealed declining TBT concentrations in the U.S., Europe, and Japan [1, 6-10]. For instance, since passage of OAPCA, median TBT concentrations in U.S. marine waters generally have averaged less than 10 ng/L, the EPA [5] chronic marine water quality criterion [11]. Concentrations in the freshwater region monitored (Lake Erie) have been less than EPA's freshwater chronic water quality criterion, 63 ng/L, since 1991 [11].

¹ This manuscript is an Executive Summary of the manuscript submitted for publication, space did allow for publication of the full manuscript in the Oceans '99 Proceedings, a complete version of this manuscript can be found in: R.D. Cardwell, M.S. Brancato, J. Toll, D. Deforest, and L. Tear. 1999. Aquatic Ecological Risks Posed By Tributyltin in U.S. Surface Waters: Pre-1989-1996 Data. Environmental Toxicology and Chemistry 18(3):567-577.

² Tel (425) 822-8880, FAX (425) 889-8808, rcardwell@parametrix.com

The objective of this study was: 1) to determine acute and chronic risks to aquatic life from exposure to TBT in U.S. surface waters, and 2) to evaluate regional and source-related (e.g., marinas, commercial harbors, shipyards) differences in risks. Risks in saltwater were emphasized because fouling on boat hulls is generally higher in saltwater versus freshwater, therefore TBT use is higher on saltwater vessels. The risk assessment approach used is probabilistic because it models variability in estimated TBT exposure levels as well as in TBT's acute and chronic toxicity to aquatic organisms.

RISK CHARACTERIZATION METHODS

Acute and chronic risks were estimated by comparing distributions for TBT EECs and effects thresholds. The estimated risk for any given EEC equals the percentage of taxa affected at that EEC. The probability associated with this level of risk is the probability that the stated EEC will occur. For the entire distribution of TBT concentrations ($R(\text{EEC})$), the percentage of taxa expected to be at risk is plotted against ($f(\text{EEC})$), the probability associated with the EEC. This creates the risk PDF. Expected total risk is found by summing (or integrating) the product $R(\text{EEC}) \cdot f(\text{EEC})$. Expected total risk can also be considered a weighted average where risks associated with a given EEC are weighted by the probability of occurrence. Table 1 exemplifies the probabilistic risk estimation method. For example, a TBT concentration range of 0 - 5 ng/L encompasses 47 percent of the EECs, and within the 0 - 5 ng/L range only 0.041 percent of the taxa will be affected. The percent taxa at risk is $47\% \times 0.041\% = 0.019\%$. The statistical expectation of the risk is simply the sum (or integral in the continuous case) of the possible risk levels, each weighted by its probability of occurrence.

RISK CHARACTERIZATION RESULTS

The risk characterization presents the results of the probabilistic risk analysis with the percentages of taxa expected to be at acute or chronic risk of exposure to TBT concentrations in the water column. First, we discuss the risks of acute and chronic toxicity on a regional basis. This is followed by a discussion of the risks associated with the different sources of TBT; a discussion of the results that would be obtained from

a hazard quotient approach versus the approach applied herein; and last, the ecological significance of the risks and uncertainties.

Risks posed to aquatic life by TBT concentrations in U.S. surface waters have varied significantly between regions of the U.S. and the sites monitored (Tables 2a-e). At most of the sites and regions monitored, risks were low, affecting ≤ 6 percent of the species even prior to OAPCA's passage in 1988. These risks seem lower than those based on comparing a specific TBT effect criterion (e.g., 10 ng/L) to a specific EEC value or frequency (e.g., 36% of EECs exceeded the criterion). By taking a community-based approach and considering the relative sensitivity of species within that community, expected total risk (ETR) turns out to be less. Because TBT water column concentrations continued to decline over time, the majority of the characterization focuses on the ETRs calculated for 1996 because they represent the most recent data collected.

Risks of Acute Toxicity

Risks of acute toxicity have been low ($\leq 3\%$) since prior to OAPCA because TBT's acute toxicity occurs at ≥ 110 ng/L. EPA [5] has estimated the acute toxicity threshold at ≥ 356 ng/L. By 1993, there was no risk of acute toxicity in Puget Sound, Lake Erie, or Narragansett Bay. Acute risks occurred only within Galveston Bay's commercial sites, and by 1996, ≤ 1 percent of the aquatic taxa were at risk to acute toxicity at these sites.

Regional Differences in Chronic Risks

Tributyltin concentrations typifying each of the site types differed between regions, with chronic risks being higher (12 to 14% in 1996) in Galveston Bay and negligible ($\leq 4\%$) in the other regions (Tables 2a-d). The ETR for Puget Sound and Narragansett Bay in 1996 was ≤ 3 percent at all site types. In Lake Erie, risks were < 1 percent except at marinas ($\leq 2\%$). In Galveston Bay, ETRs were 12 to 14 percent at all site types except fish/shellfish habitats ($\leq 1\%$). The regional differences in risks reflect the higher EECs seen in Galveston Bay (Tables 2a-d). Leading explanations concerning Galveston Bay's elevated TBT

concentrations include greater shipping activity and naturally elevated suspended solids (8 to 155 mg/L) which offers a substrate for TBT sorption [34].

Source Differences in Chronic Risks

Expected chronic risk also varied greatly by site type (Table 2a). Over the nine plus years of monitoring (the Navy and EPA programs), ETRs have been highest in marinas (5 to 25%), followed by shipyards (5 to 6%), commercial harbors (< 1-6%), and fish and shellfish habitats proximate to these sites (< 1-2%). While this reflects differences in exposure (i.e., differences in EEC distributions), different organisms also inhabit the various site types. The latter is not a factor in the risk estimates, which assume a diverse saltwater community is attainable in commercial sites.

The site type differences were also reviewed at the regional level using 1992 - 1996 data (Tables 2b-e). The pattern was similar for Puget Sound, Narragansett Bay, and Lake Erie, where ETRs were highest in marinas (2 to 9%), low in commercial harbors and shipyards (< 1 to 5%), and even lower in fish and shellfish habitats (< 1 to 2%). While a similar pattern was seen in Galveston Bay, ETRs were higher (Table 2b). In Galveston Bay, ETRs in marinas were highest (13 to 19%), followed by shipyards (12 to 15%), commercial harbors (8 to 14%), and fish and shellfish habitats (1 to 4%).

Trends in Chronic Risks

Annual monitoring of each TBT site type from pre-OAPCA to 1996 reveals ETRs decreasing over time in saltwater marinas, the only site type where risks were high enough to track temporal trends (Table 2a). Prior to 1989, ETRs were as high as 25 percent in saltwater marinas; but by 1996, they had declined to \leq 14 percent in Galveston Bay at all four site types, and to \leq 2 percent in all Puget Sound and Narragansett Bay site types except marinas (3 - 4%) (Tables 2a-e). Risks at the Lake Erie sites have remained low (0 - 2%) since monitoring commenced in 1992. To place these risks into context, the EPA water quality criteria seek to protect all but 5 percent of the species, and the Society of Environmental Toxicology and Chemistry [25] recommends protecting all but 10 percent of the species. Economically important species and those that

influence the community out of proportion to their abundance or biomass (keystone species) also are protected.

Comparison of Risk Characterization Approaches

Risk assessments often are conducted in tiers (phases), with a screening phase based on quotients usually conducted in Tier 1 and a detailed phase based on probabilistic techniques conducted in Tier 2. Risks suggested by the two approaches may appear quite different, reflecting dissimilar assumptions and calculation methods. With the quotient method, risks appear higher because the probabilities of exposure and effect are not considered; a quotient only compares the magnitude of the ratio between the EEC and the toxicological effect threshold. In 1996, for example, 40 percent of the EECs measured in U.S. saltwater marinas and 3 percent of those in proximate fish and wildlife habitats exceeded the EPA chronic criterion of 10 ng/L, the former suggesting substantial risk. However, the WERF methodology [12] indicates the ETR to be \leq 6 percent of all saltwater species in marinas and \leq 1 percent in ecological sites. That is, on average, only < 1 - 6 percent of the taxa are predicted to be at risk of chronic toxicity in the sites and regions sampled (Table 2a).

The measure of risk used in the WERF methodology is the percentage of aquatic taxa whose effects thresholds are exceeded by the EECs to which they are exposed. Using marinas as an example, 24 percent of all EECs measured in saltwater marinas in 1996 exceeded 16 ng/L. At the latter EEC, approximately 10 percent of the saltwater taxa are expected to be at risk of chronic toxicity, i.e., to incur adverse effects on some proportion of their population given the assumptions made concerning duration and bioavailability of TBT exposure. Consequently, the ETR is 2.4 percent (24% x 10%).

The most sensitive 10 percent of taxa tested include larvae of certain bivalves (e.g., *Mercenaria*, *Crassostrea*), gastropods (e.g., the snail *Nucella*), and crustacea (e.g., the copepod *Acartia*) [5]. For example, a percentage of the quahog clam's (*Mercenaria mercenaria*) larvae are at risk when chronically exposed to 10 ng/L TBT at the veliger stage; chronic effects have been observed at 10 ng/L [5]. Because EECs in

the range of ≥ 10 ng/L occurred in 1996 40 percent of the time in marinas, it can be assumed they occurred over sufficiently long time periods to encompass bivalve larval development (~ 21 days). In 1996, risks to quahog clam larvae occurred in Galveston Bay's commercial sites; risks in the other regions were lower, as discussed below.

Ecological Significance of the Chronic Risks

Concentrations > 10 ng/L may have occurred long enough to pose chronic risk to species with short life cycles or sensitive life stages, such as developing bivalve larvae and reproduction of copepods like *Acartia tonsa* [35]. Despite the ETRs to certain species sensitive to TBT, it is not clear how chronic effects at early life history stages would affect populations as a whole. For example, a variety of indigenous bivalve species whose larvae are expected to be as sensitive to TBT as those tested in the laboratory have been collected in all of the saltwater regions monitored. The primary bivalves collected include *Mytilus trossulus* in Puget Sound, *M. edulis* and *Arcuatula demissus* in Narragansett Bay, *Crassostrea virginica* in Galveston Bay, and *Dreissena polymorpha* in Lake Erie. In Galveston Bay, where TBT concentrations were higher, bivalve populations were not as large or as frequent at some of the monitoring sites, yet it is clear that exposure is either less than predicted or that compensatory mechanisms at later life history stages may offset reductions at earlier stages.

In addition, the quoted risks are exaggerated for marinas, commercial harbors, and shipyards because they presume a balanced, diverse, and productive marine community within these sites is an attainable use. Because marinas, for instance, are managed for small boats and may be significant sources of certain pollutants in addition to TBT, it is questionable whether mollusc production, for example, would be a resource management goal and an attainable use. Generally, it is not. In addition, poor hydraulic exchange within marinas affects food supply for filter feeders, and their depositional environment limits habitat, limiting the species that can live in them [36]. Similar constraints on biodiversity occur in shipyards and in the innermost reaches of commercial harbors where we sampled.

Uncertainties in Risk Estimates

There are two categories of uncertainties in our risk estimates: data variability and assumptions. The former includes TBT detection limits. Although our data include absolute TBT quantitative limits as low as 0.5 ng/L, the MDL was 5.5 ng/L, calculated following Federal Register 40 CFR 136, Appendix B. The practical quantification limit for TBT exceeds 10 ng/L using the analytical method of Uhler and Steinhauer [37], which is being adopted as an EPA standard method (A. Uhler, personal communication). As mentioned earlier, EECs less than the MDL were set equal to one-half the MDL. This was inconsequential to the risk estimates, because any value less than the detection limit was associated with zero risk. Because risks resulted from the majority of EECs being at or near one-half the MDL, however, this creates some uncertainty in calculated means. If detection limits were lower, the risks would decline further. This would also be the case if TBT EECs were inflated by noise around the detection limit. Expected improvements in TBT detection limits should reduce this uncertainty.

Assumptions concerning EEC duration and effect thresholds represent important uncertainties. We assumed every EEC occurred long enough to elicit responses in all the species tested, but if they did not, risks were over-estimated. We also assumed exceedance of a species' effect threshold denoted risk, knowing that most thresholds represent estimates of no observed effect concentrations and do not equate with effects. To distinguish effects on individuals and those on populations, further assessment is necessary [38].

SUMMARY AND CONCLUSIONS

Tributyltin monitoring from pre-1989 through 1996 at saltwater and freshwater sites around the U.S. has revealed declines in chronic risks from a high of 25 percent, prior to late 1988 legislation restricting TBT usage, to < 1 to 14 percent in 1996, depending on site type and region. Most of the decline has been associated with marinas, which reflects limitations on use of TBT antifoulant paints on pleasure crafts. Since

1994, all risks have been associated with chronic rather than acute toxicity in all regions monitored. Most of the risks appear to have been localized to marinas (small boat basins). Low risks ($\leq 2\%$) have been observed in commercial harbors and shipyards in three of the four regions monitored for the past five years. Negligible risks ($< 1\%$) have been encountered since prior to 1989 in the fish and shellfish habitats adjacent to marinas, shipyards, and commercial harbors.

Risks were not uniform between regions of the U.S., but were inflated by TBT concentrations measured at a variety of stations within Galveston Bay, which have ranged from 1 - 19%. By 1996, risks were low ($\leq 4\%$) to negligible in the Pacific Northwest (Puget Sound, Washington), Atlantic Northeast (Narragansett Bay,

Rhode Island and Massachusetts), and the Great Lakes (Lake Erie, Ohio, Michigan, and Pennsylvania). Most (86 to 100%) of the aquatic species are not expected to be at risk from TBT surface water concentrations observed in 1996. The species at risk occupy the lower tenth percentile in terms of TBT sensitivity. They include the economically important larvae of bivalves, (*Mercenaria*, *Crassostrea*, and *Ostrea*) and the ecologically important zooplankton *Acartia*. However, these species generally were at risk only in marinas, sites managed for commercial uses rather than shellfish production. Galveston Bay was the exception; the most sensitive species were at risk in marinas, shipyards, and commercial harbors, but not in proximate habitats considered suitable for fish and shellfish production.

Table 1. Example TBT expected risk calculation: saltwater marinas in 1996.

TBT Concentration (ng/L)	Percent EECs in this Range of Concentrations	Percent TBT Affected ¹	Taxa	Percent Taxa at Risk
0-5	47	0.041		0.019
6-10	14	5.7		0.80
11-20	23	9.3		2.1
21-30	9.0	13.9		1.3
31-40	3.4	18.2		0.62
41-50	1.3	21.9		0.28
51-60	0.96	25.2		0.24
61-70	0.35	28.5		0.10
71-80	0.31	31.0		0.096
81-90	0.12	33.1		0.04
91-100	0.16	35.6		0.057
101-161	0.15	42.7		0.064
Total Expected Risk				6

EEC = Expected Environmental Concentration.

Percent taxa with chronic effects thresholds occurring within the range of TBT concentrations in the first table column.

Table 2a. Expected chronic risks for all saltwater areas monitored.

Year	Expected Risks (%)			
	Marinas	Shipyards ¹	Harbors	Fish/Shellfish Habitats
Pre-1989	25	-	5	2
1989	12	-	1	1
1990	7	-	0	0
1991	7	-	1	0
1992	8	6	2	0
1993	6	6	3	0
1994	6	5	4	0
1995	5	6	4	2
1996	6	5	6	1

¹ The Navy monitoring stations were classified into the site types used on the EPA-mandated program.

Because shipyards and commercial harbors were indistinguishable, all of the Navy data meeting the harbor designation were considered as such, whether or not they contained a drydock. The EPA-mandated program began in 1992, and shipyards per se were only monitored after this time.

Table 2b. Expected chronic risks for Galveston Bay waters.

Year	Expected Risks (%)			Fish/Shellfish
	Marinas	Shipyards	Harbors	Habitats
1992	18	15	9	1
1993	19	13	8	1
1994	13	12	10	1
1995	13	13	9	4
1996	13	12	14	1

Table 2c. Expected chronic risks for Narragansett Bay waters.

Year	Expected Risks (%)			Fish/Shellfish
	Marinas	Shipyards	Harbors	Habitats
1992	2	0	0	0
1993	2	2	0	0
1994	2	1	0	0
1995	3	5	1	1
1996	4	1	1	0

Table 2d. Expected chronic risks for Puget Sound waters.

Year	Expected Risks (%)			Fish/Shellfish
	Marinas	Shipyards	Harbors	Habitats
1992	9	0	1	0
1993	4	2	3	1
1994	4	1	1	0
1995	3	1	1	1
1996	3	1	2	0

Table 2e. Expected chronic risks for freshwaters (Lake Erie).

Year	Expected Risks (%)			Fish/Shellfish
	Marinas	Shipyards	Harbors	Habitats
1992	2	0	0	2
1993	2	0	0	0
1994	2	0	0	0
1995	2	0	0	0
1996	2	0	0	0

LITERATURE CITED

- [1] Russell, D., M.S. Brancato, H.J. Bennett. 1996. Comparison of trends in tributyltin concentrations among three monitoring programs in the United States. *Mar. Sci. Technol.* 1:230-238.
- [2] Champ, M.A., P.F. Seligman, Editors. 1996. *Organotin, environmental fate and effects*. Chapman & Hall, London, UK.
- [3] Hall, L.W. Jr., M.J. Lenkevich, W.S. Hall, A.E. Pinkney, S.J. Bushong. 1987. Evaluation of butyltin compounds in Maryland waters in Chesapeake Bay. *Mar. Pollut. Bull.* 18: 78-83.
- [4] Langston, W.J., G.R. Burt, M.-J.T.I. Zhou. 1987. Tin and organotin in water, sediments and benthic organisms of Poole Harbour. *Mar. Pollut. Bull.* 18: 634-639.
- [5] U.S. Environmental Protection Agency. 1997. Draft ambient aquatic life water quality criteria for tributyltin. EPA Office of Research and Development, Environmental Research Laboratories, Duluth, USA. EPA-822-D-97-001. July 1997.
- [6] O'Connor, T.P. 1996. Trends in chemical concentrations in mussels and oysters collected along the U.S. coast from 1986 to 1993. *Mar. Environ. Res.* 32:113-129.
- [7] Länge, R. 1996. Monitoring of current levels of TBT in U.S. and European seawater and evaluation of the risk in the context of recent ecotoxicity data. Proceedings: The Present Status of TBT-Copolymer Antifouling Paints, International One Day Symposium on Antifouling Paints for Ocean-going Vessels, The Hague, The Netherlands, February 21, 1996, pp. 28-35.
- [8] Seligman, P.F., J.G. Grovhoug, A.O. Valkirs, P.M. Stang, R. Fransham, M.O. Stallard, B. Davidson, R.F. Lee. 1989. Distribution and fate of tributyltin in the United States marine environment. *Appl. Organomet. Chem.* 3:31-47.
- [9] Seligman, P.F., J.G. Grovhoug, R. Fransham, B. Davidson, and A.O. Valkirs. 1990. U.S. Navy statutory monitoring of tributyltin in selected U.S. harbors, annual report: 1989. Technical Report 1346. U.S. Naval Office Systems Center, San Diego, CA, USA.
- [10] Evans, S.M., T. Leksono, P.D. McKinnell. 1995. Tributyltin pollution: A diminishing problem following legislation limiting the use of TBT-based anti-fouling paints. *Mar. Pollut. Bull.* 30:14-21.
- [11] Parametrix, Inc. 1997. Annual Report: Year 5, 1996-1997. Long-Term National Monitoring Program for Tributyltin and Its Primary Intermediates. Parametrix, Kirkland, WA, USA.
- [12] Parkhurst, B., W. Warren-Hicks, R. Cardwell, J. Volosin, T. Etchinson, J. Butcher, and S. Covington. 1995. Risk managing methods. *Water Environment. Technol.* 7:39-43.
- [13] Hall, L.W., Jr. 1988. Tributyltin environmental studies in Chesapeake Bay. *Mar. Pollut. Bull.* 19: 431-438.
- [14] U.S. Congress. 1988. Organotin Antifouling Paint Control Act of 1988. H.R. 2210-3. One Hundredth Congress of the United States of America, Second Session, Washington, DC, USA
- [15] Alzieu, C, G. Barbierm and J.T.I. Sanjuan. 1987. Copper levels evolution in Arcachon Bay oysters: Role of the regulation on antifouling paints. *Oceanol. Acta.* 10:455-461.
- [16] Side, J.T.I. 1987. Organotins — not so good relations. *Mar. Pollut. Bull.* 18:205-206.
- [17] Lee, R.F. 1985. Metabolism of tributyltin oxide by crabs, oysters and fish. *Mar. Environ. Res.* 17:145-148.
- [18] Meador, J.P., C.A. Krone, D.W. Dyer, U. Varanasi. 1997. Toxicity of sediment-associated tributyltin to infaunal invertebrates: Species comparison and the role of organic carbon. *Mar. Environ. Res.* 43:219-241.
- [19] Yamada, H., M. Tateishi, and K. Takayanagi. 1994. Bioaccumulation of organotin compounds in the red sea bream (*Pagrus major*) by two uptake pathways: dietary uptake and direct uptake from water. *Environ. Toxicol. Chem.* 13:1415-1422.
- [20] DiToro, D.M., C.S. Zarba, D.J. Hansen, W.J. Berry, R.C. Swartz, C.E. Cowan, S.P. Pavlou, H.E. Allen, N.A. Thomas, P.R. Paquim. 1991. Technical basis for establishing sediment quality criteria for nonionic organic chemicals by using equilibrium partitioning. *Environ. Toxicol. Chem.* 10:1541-1583.
- [21] Stephan, C.E., D.I. Mount, D.J. Hansen, J.H. Gentile, G.A. Chapman, W.A. Brungs. 1985. Guidelines for deriving numerical national water quality criteria for the protection of aquatic organisms and their uses. U.S. Environmental Protection Agency, Washington, DC, USA. NTIS PB85-227049.
- [22] U.S. Environmental Protection Agency. 1995. Draft proposed guidelines for ecological risk assessment. (EPA/630/R-95/002) U.S. EPA, Risk Assessment Forum. Washington, DC, USA.

- [23] U.S. Environmental Protection Agency. 1994. Water quality standards handbook: Second edition. (EPA-823-B-94-005a) EPA, Office of Water, Washington, DC, USA.
- [24] Aldenberg, T. and W. Slob. 1993. Confidence limits for hazardous concentrations based on logistically distributed NOEC toxicity data. *Ecotoxicol. Environ. Safety* 25:48-63.
- [25] Society for Environmental Toxicology and Chemistry. 1994. Aquatic risk assessment and mitigation dialogue group. Final report. SETAC Foundation for Environmental Education, Inc., Pensacola, Florida, USA.
- [26] BestFit. Palisade Corporation, Newfield, NY, Version 2.0d, 1996.
- [27] @Risk. Palisade Corporation, Newfield, NY, Version 3.1, 1995.
- [28] Prothro, M.G. 1993. Office of Water policy and technical guidance on interpretation and implementation of aquatic life metals criteria. U.S. EPA, Office of Water, Washington, D.C. 7 pp + appendices. In EPA 1994. Appendix J, Water Quality Standards Handbook, 2nd Edition. EPA-823-B-94-005A.
- [29] Unger, M.A., W.G. MacIntyre, and R.J. Huggett. 1988. Sorption behavior of tributyltin on estuarine and freshwater sediments. *Environ. Toxicol. Chem.* 7:907-915.
- [30] Laughlin, R.B. Jr. 1996. Bioaccumulation of TBT by aquatic organisms. In M.A. Champ and P.F. Seligman, editors, *Organotin: Environmental Fate and Effects*, 1st ed., Chapter 16. Chapman and Hall, London, U.K., pp. 331-356.
- [31] ASTM. 1987. Standard practice for conducting acute toxicity tests with fishes, macroinvertebrates, and amphibians. pp. 400-424. In: Volume 11.04, 1987 Annual Book of ASTM Standards. ASTM, Philadelphia, PA.
- [32] Mount, D.I. and C.E. Stephan. 1967. A method for establishing acceptable toxicant limits for fish - malathion and the butoxyethanol ester of 2,4-D. *Trans. Amer. Fish. Soc.* 96:185-193.
- [33] Gentile, J.H. and M.W. Slimak. 1992. Endpoints and indicators in ecological risk assessments. In D.H. McKenzie, D.E. Hyatt and V.J. McDonald, eds. *Ecological Indicators*, Elsevier Applied Science, New York, New York.
- [34] Langston, W.J. and N.D. Pope. 1995. Determinants of TBT adsorption and desorption in estuarine sediments. *Mar. Poll. Bull.* 31:32-43.
- [35] Bushong, S.J., M.C. Ziegenfuss, M.A. Unger, and L.W. Hall, Jr. 1990. Chronic tributyltin toxicity experiments with the Chesapeake Bay copepod, *Acartia tonsa*. *Environ. Toxicol. Chem.* 9:359-366.
- [36] Reish, D.J. 1963. Further studies on the benthic fauna in a recently constructed boat harbor in southern California. *Bull. South. Calif. Acad. Sci.* 62:23-32.
- [37] Uhler, A.D. and W.G. Steinhauer. 1988. Measurement of butyltin species in water by n-pentyl derivatization with gas chromatography/flame photometric detection (GC/FPD) and optional confirmation by gas chromatography/mass spectrometry (GC/MS). Method approved by EPA 13 February 1989. Battelle Ocean Sciences, Duxbury, Massachusetts.
- [38] Barnthouse, L.W., G.W. Suter II, and S.M. Bartell. 1988. Quantifying risks of toxic chemicals to aquatic populations and ecosystems. *Chemosphere* 17:1487-1492.

An Evaluation of Risks to U.S. Pacific Coast Sea Otters Exposed to Tributyltin¹

**D. MacLellan, M.S. Brancato, D. DeForest, and J. Volosin
Parametrix, Inc., 5808 Lake Washington Boulevard N.E., Suite 200,
Kirkland, Washington 98033**

ABSTRACT

Recent studies have suggested that tributyltin (TBT) and other butyltins may contribute to the deaths of sea otters (*Enhydra lutris*) off the California coast. Although butyltins have been measured in tissues from the dead otters, no cause-and-effect relationship links these tissue residues to the otter deaths. This study assesses potential risks to U.S. Pacific coast sea otters (in California, Washington, and Alaska) from TBT in their diet. We assumed that bivalves serve as the primary food consumed. The study looked specifically at how TBT in the diet would affect the species' ability to fight disease (that is, its immune system response). Because no sea otter-specific TBT toxicity data were available, a TBT immune response endpoint was selected for study in a surrogate mammalian species (with relevant uncertainty factors noted). This endpoint was chosen because effects to the immune system occur at the lowest doses evaluated and because disease has been cited as the greatest cause of death in California sea otters. Next, the potential for risk to sea otters is estimated for individual sea otters within threatened populations, as well as for the subspecies populations of Alaska, Washington, and California as a whole.

Results indicate that no TBT-related risks are expected to any Alaska, Washington, or California sea otters foraging in the coastal waters. These waters represent the habitat where more than 99 percent of the sea otter population is known to reside and forage. A few otters, individuals that have been observed in marinas of Alaska (i.e., Seward,

Cordova, and Kodiak) and California (i.e., Monterey Bay area marinas and Morro Bay), may be at risk from TBT exposure if they forage on prey living in the marina. Because the California sea otter population is listed as threatened under the Endangered Species Act, the risks to those individual sea otters using the marina habitat were evaluated using the most conservative scenarios. For example, sea otters were assumed to feed on marina bivalves for 20 to 50 percent of their diet; it was also assumed that all TBT was 100 percent bioavailable. These assumptions probably overestimate risks, (that is, they are very conservative) because these otters are believed to consume more varied prey both inside and outside marinas, and other prey (like crab) may accumulate less TBT in their tissues than do bivalves. Risks are estimated to be negligible to the subspecies populations as a whole, because less than one percent of sea otters in California, Washington, and Alaska frequent marinas.

INTRODUCTION

Three subspecies of sea otters inhabit the Pacific coastal waters of California, Washington and Alaska. Evidence suggests that a few individuals in the California subspecies frequent marinas inside Monterey Harbor and Morro Bay (R. Jameson, 1998 personal communication, B. Hatfield, 1998 personal Communication). Otters have also been observed in marinas in Seward, Cordova, and Kodiak, Alaska (C. Gorbics, 1998 personal communication, C.E. Bowlby 1998 personal communication). Within these marinas, we speculate these otters may feed on crustaceans,

¹ This manuscript is an Executive Summary of the original 34 page manuscript submitted for publication, Space did allow publication of the full manuscript in the Oceans '99 MTS/IEEE Conference Proceedings, Vol. 2, ppg. 642-75. Please contact the author for the complete manuscript.

molluscs, and fisherman bycatch or fish scraps. We have anecdotal evidence that the otters feed on fisherman bycatch or fish scraps. Although the fish scraps are not from fish inhabiting the marinas, other food items of otters, such as molluscs and crustaceans, may inhabit marinas and be preyed upon; therefore, risks to sea otters that obtain a portion of their diet from marinas are assessed.

Butyltins bioaccumulate in some bivalves more readily than in other otter prey items, such as crustaceans and fish (Laughlin 1996), because bivalves cannot metabolize TBT as efficiently as other prey species (Laughlin 1996, Lee 1996). For this reason, sea otters feeding primarily on a diet of bivalves may be at greater risk for TBT exposure than crustacean or fish-eating marine mammals.

We undertook this study to estimate the potential risks of TBT to sea otters inhabiting the coastal waters of Alaska, Washington and California. Specifically, we assessed potential risks to sea otters foraging in areas with high boating activity, versus those foraging in their primary coastal habitat. This coastal habitat would be distant from boating areas but inclusive of harbors and bays. Affecting this study is the 1988 legislation limiting the use of TBT² in the U.S. Many studies indicate TBT concentrations in water, sediment and bivalve tissues have been declining since 1988 (Russell et al. 1996, Cardwell et al. 1998, O'Connor 1996, U.S. Navy and U.S. EPA 1997). Because of this decline, we hypothesized that sea otter exposures to TBT have been declining as well. Therefore, risks were assessed using both current and historical TBT data in bivalves. The details of the risk assessment methodology and results are presented below.

METHODS

Exposure Assessment

An exposure assessment identifies the type of TBT exposure that sea otters may experience. This assessment consists of the following processes:

- identify the exposure pathway(s),
- identify the exposure data (expected environmental concentrations) used to estimate risks, and
- quantify the exposure using simple dose models.

Exposure Pathway Identification

Given sea otter foraging habits, we assumed the predominant exposure pathway is through their food. We also assumed that other exposure pathways, such as water and sediment ingestion and dermal contact, contributed insignificantly to total TBT exposure. As discussed earlier, the sea otter diet consists primarily of bivalves (e.g., mussels), sea urchins, abalone, crab and fish (see Table 2). While most of the TBT tissue data for saltwater organisms on the west coast of the United States is derived from mussels, *Mytilus spp* (NOAA Mussel Watch Program 1998, Parametrix, Inc. 1998, Russell et al. 1996, U.S. Navy & U.S. EPA 1997), no TBT tissue data were available for other organisms in the sea otter diet. Mussels, therefore, were assumed to be the representative prey of sea otters. This is a conservative assumption because TBT is known to bioaccumulate to higher levels in bivalves than in other prey (except possibly gastropods) due to the limited ability of these organisms to metabolize and excrete TBT (Laughlin 1996, Lee 1996).

Exposure Data Identification

TBT tissue data sources used to calculate otter TBT doses included the following:

- the National Oceanic and Atmospheric Administration's (NOAA) Mussel Watch Program (downloaded from the NOAA web site),
- the U.S. Navy TBT Monitoring Program (U.S. Navy and U.S. EPA 1997), and
- the U.S. EPA-required TBT long-term monitoring program (referred to herein as LTMP) (Russell et al. 1996, Parametrix, Inc. 1998).

² The Organotin Antifouling Paint Control Act restricted use of TBT-containing paints to certain size vessels and a specific release rate.

NOAA Mussel Watch data are available for the sea otter's range in coastal waters off central California (e.g., Monterey Bay, San Luis Obispo Bay); the northwestern tip of Washington State (Cape Flattery); and for several locations in Alaska (e.g., various sites in Prince William Sound, Kachemak Bay, etc.). The NOAA Mussel Watch Program sites represent coastal areas that sea otters occupy but the sites did not target areas where elevated TBT concentrations are suspected (e.g., marinas). We could not locate site-specific marina bivalve residue data for the sites otters use. Therefore, we used marina data collected in San Diego, California (U.S. Navy and U.S. EPA 1997), and Puget Sound, Washington (Russell et al. 1996, Cardwell et al. 1998) to represent TBT residues that an otter foraging in a boating area may be exposed to through its diet. This is a very conservative approach, and risks are certainly overestimated, because bivalves in U.S. marinas have higher TBT concentrations than those in harbors (Russell et al. 1996, Parametrix, Inc. 1998). Several years of tissue data are available for each of these sources: NOAA data from 1989 – 1996;

Navy data from 1986 – 1992, and LTMP data from 1992 – 1997. As necessary, TBT tissue concentrations were converted to wet weight and expressed as TBT cation.

Because one of the objectives of this risk assessment is to evaluate current risk versus trends in risk over time (for sea otters exposed to TBT), the data were evaluated separately for each year sampled. Only single composite samples were available for the NOAA data for each location for each year sampled. However,

for the Navy and LTMP data, multiple samples were available for each year sampled (e.g., 15). Thus, for the Navy and LTMP data, means were calculated and used in the risk assessment. To evaluate the variability in the NOAA single-point composite sample data (concentrations for each station are from a composite sample of multiple mussels), the data from all of the California locations near sea otter populations were combined (on a yearly basis) to evaluate overall exposures to the California otter population. In Washington State only one NOAA sampling station was monitored; therefore, data from the single station were used to represent Washington coastal waters. For Alaska, we did not make a distinction in the NOAA stations that were located near otter populations because TBT residue data were non-detects at all stations except one.

TBT tissue data used in this study indicate that TBT concentrations tend to be much greater in marinas than in coastal waters (suggesting that TBT contamination is localized to its source), and that tissue concentrations continue to decrease with time. The tissue data represent TBT concentrations from the sea otter's food and are used to estimate TBT doses to otters, as discussed below.

Quantification of Sea Otter Exposures

Sea otter TBT exposure was quantified by estimating the daily dose (mg TBT/kg body weight) that sea otters would receive from ingesting TBT in their food, as shown in equation (1):

$$\text{TBT Dose (mg/kg/d)} = \frac{C_{\text{food}} \times \text{IR}_{\text{food}}}{\text{BW}} \quad (1)$$

Where:

C_{food}	=	TBT concentration in food (mg/kg-wet)
IR_{food}	=	Food ingestion rate (kg/day-wet)
BW	=	Sea otter body weight (kg)

The food ingestion rates and body weights used for California, Washington, and Alaska sea otters appear in Table 5. As explained in detail in the Risk Characterization Methods, TBT doses were assessed using mean TBT tissue data, as well as probabilistically, to address the variability in the TBT tissue concentrations. The mean tissue concentration was used to estimate exposure because over a chronic (i.e., long-term) duration otters will feed on bivalves with both relatively high and relatively low TBT concentrations (i.e., they are unlikely to exclusively feed on just bivalves with high concentrations or just bivalves with low concentrations). Because sea otters are exposed to an average TBT concentration in their food over a chronic duration, variability in the mean concentration was evaluated rather than variability in individual concentrations.

RISK CHARACTERIZATION

Potential risks to sea otters from ingesting TBT in bivalves were estimated using the hazard quotient (HQ) approach, where:

$$\text{Hazard Quotient} = \frac{\text{TBT Dose}}{\text{Toxicity Threshold Value}} \quad (2)$$

Hazard quotients were calculated using single point estimates based on mean or single point TBT tissue data (depending on the data source) and the average of the NOAEL and LOAEL for each immune suppression effect. The average approximates the true toxic threshold dose, which is somewhere between these two values. Hazard quotients were calculated assuming ingestion of 100 percent bivalves from coastal areas (NOAA Mussel Watch data) and assuming 10, 20, 30, or 50 percent of the diet consisted of marina bivalves and the remainder was coastal bivalves.

In addition, hazard quotients were also evaluated probabilistically for California otters to quantitatively assess uncertainty in the dose estimates and in the toxicity threshold values. Uncertainties in the HQs were quantified using the normal distribution of TBT exposure concentrations described in the Exposure Characterization and the uniform distribution of toxic thresholds explained in the Toxicological Effects Characterization. These distributions are inserted into

the HQ model shown in Equation 2 above, and Monte Carlo analysis is used to create a distribution of HQs.

Monte Carlo analysis involves running a model (in this case, the HQ model) and repeatedly performing the calculation using randomly selected sets of input values (i.e., TBT tissue concentrations and toxicity thresholds) each time. While the input values are randomly selected, the selection of values is a function of their probability of occurrence. For example, see the normal probability distribution below:

Concentrations (on the horizontal axis) corresponding to the taller part of the curve are more likely to occur than concentrations corresponding to shorter parts of the curve, and concentrations that do not lie below the curve have a probability of occurrence at (or very close to) zero. The model (in this case the HQ calculation) is sampled thousands of times to define the probability distribution of HQs. The probability distribution of HQs can be used to estimate the mean HQ, the upper and lower bound HQs, or the probability of exceeding an HQ of 1.0 (or any other HQ).

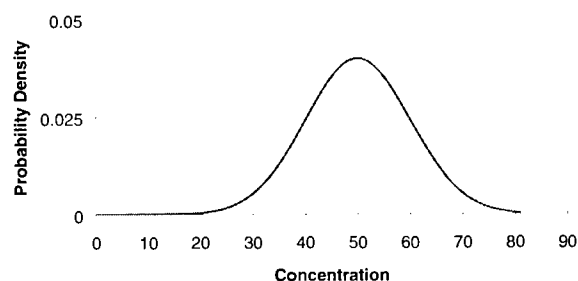

Example of normal probability distribution.

RESULTS

Summary of Results

Overall, current and historical data suggest that sea otters inhabiting the coastal areas of California, Washington, and Alaska $\frac{3}{4}$ which feed on bivalves, fish, or other invertebrates $\frac{3}{4}$ are not expected to be at risk from exposures to TBT. Nor are the few sea otters feeding within marinas, which comprise less than 1 percent of the population in California and Alaska, currently at risk from exposure to TBT. This assumes that less than 10 percent of their diet consists of bivalves living in the marina. This finding also assumes sea otters are at least four times more sensitive to TBT than rats.

Potential risks to California sea otters may currently exist if they:

- increase the frequency with which they feed in marinas such that greater than 20 percent of their diet is from within marinas,
- and they feed exclusively on bivalves in the marina,
- and are eight times more sensitive to TBT than a rat (the surrogate test species).

Potential risks to Alaska sea otters may currently exist if they:

- increase the frequency with which they feed in marinas such that greater than 30 percent of their diet is from within marinas,
- and they feed exclusively on bivalves in the marina,
- and are four times more sensitive to TBT than a rat (the surrogate test species).

For sea otters feeding on fisherman's by-catch and prey other than bivalves (e.g., crab), exposures are expected

to be lower and may not exceed the toxic threshold dose for immune suppression (based on a moderate decreased resistance to roundworm infections). This is so because, even if the prey is living within the marina, it is expected to metabolize TBT more efficiently than bivalves (Laughlin 1996; Lee 1996), and therefore, accumulate less TBT. No risks are currently expected for any sea otters feeding inside or outside of marinas when TBT intakes are compared to immune suppression endpoints for decreased thymus weight or strong decreased resistance to roundworm and bacterial infections.

Historical marina data suggest potential risks to sea otters, if one assumes they fed exclusively on marina bivalves and that sea otters are four (Alaska) to eight (California) times more sensitive to TBT than the rat.

CONCLUSIONS

Concerns exist that TBT may be posing risks to marine mammals, such as sea otters, off the U.S. Pacific coast. This concern has been raised because TBT

Table 12. Mean and upper and lower bound hazard quotients (HQs) for California sea otters exposed to TBT in marina bivalves collected in 1997.

	Effect Endpoint			
	Moderate Decreased Resistance to Roundworm Infection		Decreased Thymus Weight and Strong Decreased Resistance to Roundworm and Bacteria Infection	
	Males	Females	Males	Females
Bivalve diet from within marinas = 50%				
5 th Percentile HQ =	1.62	1.47	0.16	0.15
50 th Percentile HQ =	3.13	2.85	0.31	0.28
95 th Percentile HQ =	11.88	10.62	1.19	1.08
Probability of Exceeding Toxic Threshold	100%	100%	5%	5%
Bivalve diet from within marinas = 30%				
5 th Percentile HQ =	1.02	0.91	0.10	0.09
50 th Percentile HQ =	1.93	1.75	0.19	0.18

Table 12. Mean and upper and lower bound hazard quotients (HQs) for California sea otters exposed to TBT in marina bivalves collected in 1997.

95 th Percentile HQ =	7.40	6.61	0.73	0.07
Probability of Exceeding	100%	95%	0%	0%
Toxic Threshold				
Bivalve diet from within marinas = 20%				
5th Percentile HQ =	0.69	0.64	0.07	0.06
50th Percentile HQ =	1.33	1.22	0.13	0.12
95th Percentile HQ =	5.05	4.65	0.50	0.46
Probability of Exceeding	70%	60%	0%	0%
Toxic Threshold				
Bivalve diet from within marinas = 10%				
5th Percentile HQ =	0.40	0.36	0.04	0.04
50th Percentile HQ =	0.74	0.67	0.07	0.07
95th Percentile HQ =	2.83	2.56	0.28	0.25
Probability of Exceeding	30%	30%	0%	0%
Toxic Threshold				

concentrations have been measured in dead sea otters (Kannan et al. 1998). We evaluated risks from exposure to TBT to the three subpopulations of sea otters in Alaska, Washington, and California. To evaluate the effects of TBT on sea otters, we assumed a diet of bivalves, knowing this would provide a conservative estimate of TBT exposure because bivalves bioaccumulate TBT and cannot metabolize TBT as readily as fish or other invertebrates (Laughlin 1996, Lee 1996). We also calculated risks based on the percentage of the diet coming from bivalves living in the marina (i.e., 50, 30, 20 and 10 percent). Finally, because site-specific data were lacking for Alaska and California marinas, where a few individual sea otters have been observed, marina data from Puget Sound, Washington, and San Diego, California, were used. For all other locations, site-specific data were available through the NOAA Status and Trends Mussel Watch Program.

Immune suppression was the endpoint chosen for this assessment because butyltins are documented as immunosuppressants, and because reproduction is not as sensitive an endpoint. No TBT toxicity data for sea otters could be located; therefore, toxicity data for the rat (surrogate species) were used, with body weight scaling applied to adjust for the difference in metabolism, and with uncertainty factors of four and eight applied, to adjust for the difference in the species being assessed, and whether the sea other population was threatened or not.

In coastal waters, regardless of location or the uncertainty factor applied, all HQs calculated using current data were less than one, the level where a potential for risk is assumed. The only potential risks to otters from TBT exposure were observed in marinas. These risk predictions varied depending on the uncertainty factor used and the percent of diet obtained

in marinas. Overall, risks to Alaska otters frequenting marinas were evident only when greater than 30 percent of the diet consisted of marina bivalves. Risks to California sea otters were evident when greater than 20 percent of their diet consisted of marina bivalves. Risk predictions were also similar between male and female otters. These risk predictions are based on exposures exceeding a moderate immune suppression response. However, when exposure levels were compared to strong immune suppression responses, no risks were predicted for sea otters that may forage in marinas. Finally, risks were negligible to the population as a whole, because less than one percent of California, Washington, and Alaska sea otters frequent marinas.

REFERENCES

- Cardwell, R.D., M.S. Brancato, J. Toll, D. DeForest, and L. Tear. 1998. Aquatic ecological risks posed by tributyltin in U.S. surface waters: pre-1989 – 1996 data. In Press: Environmental Toxicology and Chemistry.
- Kannan, K., K.S. Guruge, N.J. Thomas, S. Tanabe and J.P. Giesy. 1998. Butyltin residues in southern sea otters (*Enhydra lutris nereis*) found dead along California coastal waters. *Environmental Science and Technology*. 32:1169-1175.
- Kenyon, K.W. 1969. The sea otter in the eastern Pacific Ocean. *North American Fauna*. 68:1-352.
- Laughlin, R.B. Jr. 1996. Bioaccumulation of TBT by aquatic organisms. Pages 331-368 in M.A. Champ and P.F. Seligman, editors. *Organotin*. Chapman and Hall, London.
- Lee, R.F. 1996. Metabolism of tributyltin by aquatic organisms. Pages 369-382 in M.A. Champ and P.F. Seligman, editors. *Organotin*. Chapman and Hall, London.
- NOAA Mussel Watch Program. 1998. NOAA's National Status and Trends Program [Data downloaded]. Online posting. <http://www-orca.nos.noaa.gov/projects/nsandt.htmls>. Netscape Navigator. Access data of June 1998.
- O'Conner, T.P. 1996. Trends in chemical concentrations in mussels and oysters collected along the U.S. coast from 1986 to 1993. *Marine Environmental Research*. 32:113-129.
- Parametrix, Inc. 1998. Annual Report: Year 6, 1997-1998. Long-Term National Monitoring Program for Tributyltin and Its Primary Intermediates. Prepared by Parametrix, Inc., Kirkland, Washington, United States. 2803 pp.
- Russell, D., M.S. Brancato, and H.J. Bennett. 1996. Comparison of trends in tributyltin concentrations among three monitoring programs in the United States. *Marine Science and Technology*. 1:230-238.
- U.S. Navy and U.S. Environmental Protection Agency. 1997. Navy program to monitor ecological effects of organotin. Required under the National Defense Authorization Act for FY 1997. 80 pp.

Impacts of Invasive Species Introduced through the Shipping Industry – An Overview and the Role of Policy-Makers

**M.S. Brancato, D. MacLellan and D. Hammons. Parametrix, Inc.
5808 Lake Washington Blvd. N.E., Kirkland, W A 98033**

ABSTRACT

Invasive species—also called exotic, nuisance, nonnative, or non-indigenous species—have been introduced inadvertently into many fresh and marine waters by the shipping industry. These species are transported as fouling organisms on ship hulls and in the ballast water and sediments of ships, resulting in the transport of organisms across oceans, as well as between coastal ports. Ballast water samples have included a broad range of species including most trophic levels. While most ship fouling is associated with sessile invertebrates and plants, evidence suggests that mobile species, such as fish, can also accompany a heavily fouled vessel. The degree of fouling on ships, fishing vessels, and private boats has been reduced through the use of antifoulant paints. Prior to their use, about one-third of the introduced species in Australia are believed to have been transported via fouling organisms on the hulls of overseas vessels. Some fouling still occurs today, especially in situations where antifouling paint cover is chipped, difficult to apply, or otherwise ineffective. In addition, ballast water exchange activities continue to introduce non-native species. Invasive species can have adverse ecological and economic impacts by causing declines in native species through habitat alteration or by out-competing native species, and thus, permanently reducing biological diversity. Mariculture and commercial and recreational fishing can also be adversely affected because the new invading species are predators, competitors, and parasites, and some cause or carry disease.

Finally, some invasive species, such as toxic dinoflagellates and cholera-causing bacteria, can affect human health as well.

Key Words: invasive species, fouling, ballast water, antifouling

INTRODUCTION

Invasive species have been introduced to new ecosystems by various pathways, a primary one being the shipping industry, both in ballast water and sediment, and on fouled hulls. This type of transport has been referred to as “floating biological islands” (Carlton 1985). Once established, invasive species can cause considerable adverse environmental effects by competing with native species or introducing disease (Williams and Sinderman 1991). They can also cause millions of dollars worth of economic impacts (Carlton and Geller 1993, MDEQ 1999).

The introduction of invasive species is certainly not a new phenomenon. It is expected that invasive species have spread around the world via shipping for the past several centuries. Most likely first on the fouled hulls of wooden ships, then as ballast when hard ballast was replaced with water, and now through both means. Prior to the use of current day antifoulants, tar and waxes were used to help prevent fouling on wood ships. Later came copper plates, and with the move to steel hulls, antifouling paints containing a variety of chemicals. Some of these chemicals are now well-known for their toxic effects, such as DDT, arsenic, and organomercury (Bennett 1996). Others used metals, such as silver, copper, zinc and tin. Copper

and tributyltin are the predominant compounds in use in antifouling paints for ocean-going vessels today.

Over the 20th century marine transportation has expanded rapidly. Shorter port turn-around times and faster methods of travel have led to an increase in the risk of unintended introductions (Minchin and Sheenan 1995). Ballast water exchange - whereby water (and accompanying organisms) from one location is used as ballast for travel between ports, upon which it is emptied from the ballast tanks to take on cargo, releasing the organisms in the ballast tanks to the new area - is a major source of species introductions. Although ballast water exchange continues to be evaluated by the United Nations International Maritime Organization (IMO), thus far, ballast exchange practices still raise concern. Add to this, a move towards changes in hull antifouling practices from biocides to non-biocidal antifouling methods, and one can expect an ever-greater number of introductions. In addition, changing global environmental conditions may influence species introductions. Introductions may increase if worldwide water temperatures increase due to global warming (Gollasch in prep, Hine 1995).

DISCUSSION

The number of invasive species introductions ranges by region and compatibility of the area. For instance, it is believed that at least 140 species have been introduced to the Great Lakes (US and Canada) (MDEQ 1999). Reise et al. (1999) estimates that 80 species have been introduced to the North Sea. Cohen and Carlton (1995) indicate 253 species have been introduced to San Francisco Bay, California. Introductions are greater in estuaries versus the open coast (Reise et al. 1999).

Carlton and Geller (1993) document 367 taxa present in plankton samples from the ballast water of a ship travelling from Japan to Oregon. Heretofore, ballast water exchange has been

considered the primary route of introductions from the shipping industry; however, recent studies indicate that fouled hulls are actually primary contributors (Reise et al. 1999, CSIRO 1999, Rainer 1995, Gollasch in prep), even with today's highly effective antifouling practices in place. At the Marine Corrosions conference in Melbourne, Australia, February 1999, Dr. Minchin (pers. comm.) confirmed that even though TBT-based paints are effective, hull fouling still remains an important problem. He noted that a ban on TBT is likely to lead to further increases of fouling biomass on ships hulls, which will likely lead to an escalation of invasions.

Gollasch (in prep) indicates that in his North Sea study, more than twice as many invasive species were found on fouled hulls than in ballast water. He also found that an average of 14 percent of the hull surface was fouled on the 131 mainly container ships he sampled. These new findings further support that fouled ship hulls are a primary route of invasive species introductions world-wide. Rainer (1995) concludes that prior to the introduction and widespread use of antifouling paints about one-third of the invasive species introduced into Australia came from fouled hulls of overseas trade ships. With the introduction of effective antifouling paints, there has been a reduction of fouled hulls, considerably reducing the risk of invasive organism introductions. Since 1972, the use of antifouling coatings containing TBT has significantly decreased the risk of introductions by fouling organisms. Carlton (1993) also notes that the degree of fouling on ships, fishing vessels, and private boats has been reduced through the use of antifoulant paints, and thus, has reduced the introduction of organisms via ship fouling (CSIRO 1997, Elston 1997). However, despite this reduction, fouling still occurs today, especially in situations where antifouling paint is damaged, difficult to apply, or otherwise ineffective, and as Gollasch (in prep) found, invasive species were present in 98 percent of the 131 hull samples collected and these were

primarily from container ships. In addition, Gollasch also found that the fouling organisms on ship hulls had the highest potential for establishment in new areas.

Recently, with the IMO review of harmful biocides in antifoulants, the pathway of invasive species introductions via ship fouling is being revisited. In fact, at the 1999 Corrosions Conference in Melbourne, Australia, the session on invasive species discussed hull fouling as a primary route of introduction of invasive species. Ships have the unique ability, through both ballast and fouling, to transport a very broad array of organisms to all coastal and inland waterways around the world in a manner the organisms could never achieve on their own.

FACTORS AFFECTING INTRODUCTION

Several factors affect the establishment of invasive species into a new area including environmental tolerance of the invasive species (e.g., to changes in water temperature and salinity), species interactions, food availability, and species competition in the new area. Obviously, the more similar the new area is to their native habitat, the more likely the introduced species will successfully establish. Water temperature and salinity of the potential new area are key in the establishment of species in a new area (Carlton 1985)

Carlton (1987) identified 14 major transoceanic routes and 4 interoceanic routes, with primary receivers (Hawaiian Islands, Australasia, and the Pacific Coast of North America), and donors (Australasia, Japan, and the Indo-Pacific) environments. He notes that donor environments tend to be from continental climates, while receivers have more maritime climates.

Recent data indicates that the use of antifouling paints may be important in preventing the introduction or expansion of invasive species in an area. At the Marine Corrosions conference in

Melbourne, Australia, February 1999, Dr. Minchin (pers. comm.) reported that the spread of zebra mussels (*Dreissena polymorpha*), an introduced species to Ireland, probably from fouled hulls of British boats or Dutch ferries, appeared to be controlled by the presence of TBT. Dr. Minchin believes that a TBT ban will likely lead to an escalation of invasions. He also stated that although TBT is an effective antifoulant, hull fouling remains a problem. Whatever antifouling agents are introduced will need to be as effective or better than TBT to prevent further invasions.

IMPACTS OF HARMFUL INVASIVE SPECIES

Invasive species can potentially constitute a serious ecological, economic and public health problem in any area they successfully colonize. Invasive species may out-compete or change habitats to such an extent that they make it impossible for native species to survive. Development of and/or investment decisions in fisheries and aquaculture may be constrained if invasive species harmful to native and/or cultured species become established in a region. Some invasive species may also affect native species and humans directly by causing illness or even death (e.g., harmful algal blooms and associated biotoxins). Invading species are often predators, competitors or parasites. Some invasive species can cause or carry disease so severe that they can change ecosystems and that a parasite with suitable intermediate host requirements could be spread throughout the world via ships (Williams and Sindermann 1991). Regardless of the direct or indirect nature of the effect, invasive species can significantly affect human health, devastate ecosystem, fishery and aquaculture resources, and severely impact human economy.

The economic impacts of introductions can be severe - in the millions of dollars (U.S). For instance, some of the algae causing harmful algal blooms are thought to have been transported into

new areas in the ballast water of coastal and transoceanic vessels (UNESCO 1991). These represent some of the better known and documented instances of successful invaders causing great harm at a considerable cost. About one fourth of bloom-causing species produce toxins that may harm or kill higher forms of life such as zooplankton, shellfish, fish, birds, marine mammals, and even humans, that feed either directly or indirectly on the algae. In addition, some bloom-causing species do not produce toxins but affect organisms indirectly through other means, such as decreasing light penetration, oxygen depletion, etc.

EXAMPLES OF INVASIVE SPECIES IMPACTS

- The comb jelly (*Mnemiopsis leidyi*), introduced to the Black Sea via the shipping industry in the early 1980s, **now comprises up to 95% of the biomass in the Black Sea** (CSIRO 1998). It feeds on zooplankton, eggs and fish larvae. The comb jelly reduced the anchovy fisheries from hundreds of thousands of tons to tens of thousands; thus, **collapsing a fishery worth US\$250 million/year** (Harbison and Volovik 1994).
- The European featherduster worm (*Sabella spallanzanii*) was introduced into Australian waters likely as a fouling organism on ship hulls. The worm forms large mats that smother other sea life and it competes for food with native species. In Port Phillip Bay, near Melbourne, Victoria, Australia **it poses a major threat to the local scallop industry, which is worth an estimated A\$15 million annually (~ \$11 million/US)** (Bonny 1995).
- The Japanese kelp (*Undaria pinnatifida*) and the Japanese seastar (*Asteria amurensis*) were introduced to Southeastern Australia, Tasmania and New Zealand (kelp only) via the shipping industry. The kelp competes for

space with native marine life and the seastar consumes native shellfish (e.g., abalones). These two species, along with a toxic dinoflagellate (*Gymnodinium catenatum*) **are believed to have cost the shipping, mariculture and fishing industry millions of dollars annually in Australia** (CSIRO 1997).

- The European green crab (*Carcinus maenas*) has been introduced to the east and west coasts of the US, as well as to the waters of Australia, Brazil, Panama and South Africa (Grosholz and Ruiz 1996). Introductions to the US are likely the result of ballast water or from crabs clinging to heavily fouled ship hulls. Green crabs eat molluscs, crustaceans, polychaetes and green algae. They have been **linked to the decline in the scallop fishery in the northeast US and concern for the Dungeness crab fishery on the west coast of the US** (Fincham 1996; Copping and Smith 1998). European, South African and California studies indicate the green crab has the potential to **significantly alter the distribution, density and abundance of prey species, and thus profoundly alter the ecology where it has been introduced**. It has a very diverse diet, can inhabit a broad range of habitats, and it can tolerate a wide range of temperatures and salinities, making it one of the more threatening introduced species to North America. It has been shown to reduce native populations of invertebrates in controlled experiments (Grosholz and Ruiz 1995), and it has reduced populations of bivalves on the east coast of North America (Glude 1955). In 1995, Grosholz and Ruiz predicted that it will significantly affect embayments along western North America, and in only 10 years it has made its way from San Francisco Bay, California where it was first documented in 1989-90, to Washington and British Columbia in 1999.

- The Asian bivalve *Potamocorbula amurensis*, which **changed the structure of the entire food web in San Francisco Bay** (Kimmerer et al. 1994).
- The snail *Littorina littorea* that was introduced to the northern east coast of the US via ship hulls, probably bringing with it the parasite trematode *Cryptocotyle lingua* (Williams and Sindermann 1991). The trematode now has several intermediate hosts along the north Atlantic coast, causing negative alterations in each of their population dynamics.
- Zebra mussel (*Dreissena polymorpha*) in the Great Lakes has been estimated to have a potential economic impact of \$5 billion over the next 10 years to industries (water suppliers, power plants, ships and fisheries) in that region (MDEQ 1999).

Several species of invertebrates, plants, and fish have been introduced via the shipping industry, although their economic and ecological impacts may not have been quantified. Some examples of invasive species, with an emphasis on those species introduced via fouled hulls, include the following:

Fish

Japanese sea bass – *Lateolabrax japonicus*

Molluscs

Limpet – *Crepidula fornicata*

Chiton – *Amaurochiton glaucus*

Mussels – *Mytilopsis sallei*, *Musculista senhousia*,
Perna canaliculus

Sea snails/slugs – *Aeolidiella indica*, *Janolus hyalinus*, *Okenia plana*, *Polycera capensis*,
Godiva quadricolor

Crustaceans

Barnacles – *Balanus amphitrite*, *B. improvisus*,
Elminius modestus, *Megabalanus rosa*,
Megabalanus tintinnabulum

Crabs – *Carcinus maenas*, *Eriocheir sinensis*,
Pyromaia tuberculata, *Rhithropanopeus harrisi*, *Halicarcinus innominatus*

Isopods – *Paracereis sculpta*, *Paradella diana*,
Sphaeroma walkeri, *Cilicaca latreillei*,
Synidotea laevidorsalis, *Synidotea laticauda*

Sea Spider – *Ammothea hilgendorfi*

Annelids

Polychaetes (marine worms) – *Boccardia proboscidea*, *Goniadella gracilis*,
Hydroides dianthus, *H. ezoensis*, *Janua brasiliensis*, *Marenzelleria viridis*,
Pileolaria berkeleyana, *Sabella spallanzanii*, *Ficopomatus enigmaticus*

Echinoderms – (sea star) *Asterias amurensis*

Cnidaria

Sea Anemones – *Haliplanella luciae*, *Bougainvillia ramosa*

Hydrozoa – *Clavopsella navis*, *Blackfordia virginica*, *Gonothyraea clarki*

Ascidians (sea squirts) – *Ciona intestinalis*, *Ciona savvignyi*, *Styela clava*, *Styela plicata*

Sponges – *Halichondria coalita*

Bryozoa – *Shizoporella unicornis*, *Anguinella palmata*, *Bugula flabellata*, *Conopeum tubigerum*, *Watersipora arcuata*

Parasites

Gut parasite of the mussel *Mytilus edulis*
– *Mytilicola intestinalis*

Trematode *Cryptocotyle lingua* through intermediate snail host (*Littorina littorea*), which probably was introduced on ship hulls – now also inshore fishes are intermediate hosts

Marine plants – *Solieria chordalis*, *Undaria pinnatifida*, *Antithamnionella hilgendorfi*

If less effective antifouling paints are used and ballast water exchange practices are not controlled and enforced, additional species with similar life histories to those listed above could potentially be introduced via shipping in the future.

Since much of the economic impact caused by invasive species is hard to quantify due to lack of existing data, this topic should be viewed as a potential "economic time bomb." More research on this topic is needed to quantify the potentially disastrous economic consequences of invasive species.

SUMMARY AND CONCLUSIONS

The shipping industry presents a primary pathway for invasive species introductions – both through ballast exchange and through fouled hulls. Both of these topics are currently under discussion by the IMO. In regulating the shipping industry, the IMO should consider both the direct and indirect impacts of its actions in terms of ecological and economic factors. For instance, when considering the control or elimination of all harmful biocides in antifoulant use, it should fully evaluate the ramifications of such a decision. The biocidal nature of antifoulants serve an obvious purpose – to prevent fouling organisms from establishing on ship hulls. They also serve an ancillary purpose, of reducing introductions of invasive species. Because transport of most trophic groups to destinations worldwide can be accomplished either through ballast water or ship hulls, it puts our coastal habitats at great risk. The IMO needs to consider when developing mechanisms to address, control, implement and enforce shipping practices. It would be a shame to potentially have influenced the extent of introductions through one pathway - ballast water exchange - to have it go unnoticed because of the overwhelming effects of another – the control of biocidal antifoulants. Fouled hulls have already been documented as a primary route of introductions despite current antifouling practices. The control of biocidal antifoulants needs to be balanced with the indirect benefits they

provide until an effective non-biocidal alternative is developed.

REFERENCES CITED

- Bonny, M. 1995. Preventing the invasion of marine immigrants. *Search*. 26:81-83.
- Carlton, J.T. 1993. Biological invasions and biodiversity in the sea: the ecological and human impacts of nonindigenous marine and estuarine organisms. Pages 5-11 in *Proceedings of the Conference and Workshop on Nonindigenous Estuarine and Marine Organisms (NEMO)*, NOAA, Seattle, Washington.
- Carlton, J.T. 1987. Patterns of transoceanic marine biological invasions in the Pacific Ocean. *Bull. Mar. Sci.* 41(2): 452-465.
- Carlton, J.T. 1985. Transoceanic and interoceanic dispersal of coastal marine organisms: the biology of ballast water. *Oceanogr. Mar. Biol. Annual Rev.* 23: 313-371.
- Carlton, J.T. and J.B. Geller. 1993. Ecological roulette: the global transport of nonindigenous marine organisms. *Science*. 261: 78-82.
- Cohen, A.N. and J.T. Carlton. 1995. Nonindigenous aquatic species in a United States estuary: A case study of the biological invasions of the San Francisco Bay and Delta. US Fish and Wildlife Service and the Sea Grant Program, Washington D.C. 246 pp.
- Copping, A and S. Smith. 1998. Green crab: potential impacts to the Northwest. Summary of February 9-10, 1998 Workshop held in Vancouver, Washington. www.wsg.washington.edu/outreach/mas/aquaculture/crab.html (accessed September 1998).

- CSIRO. 1997. Australia's new National Centre for Research on Introduced Marine Pests (CRIMP), Hobart, Tasmania, Australia. www.marine.csiro.au/CRIMP/ (accessed August 1998).
- CSIRO. 1998. Introduced marine pests. CSIRO Division of Marine Research, Hobart, Tasmania, Australia. www.marine.csiro.au/LeafletsFolder/marinepests.htm (accessed October 1998).
- CSIRO. 1999. Background Notes on the Port Phillip Bay Marine Pest Study by CSIRO's Centre for Research on Introduced Marine Pests. CSIRO Division of Marine Research, Hobart, Tasmania, Australia. www.marine.csiro.au/PressReleasefolder/8oct99backgrd.html (accessed October 1999).
- Elston, R. 1997. Pathways and management of marine non-indigenous species in the shared waters of British Columbia and Washington. Puget Sound/Georgia Basin Environmental Report Series: Number 5. Puget Sound/Georgia Basin International Task Force Work Group on Minimizing Introductions of Exotic Species. Olympia, 82 pp., plus appendices.
- Fincham, M.W. 1996. An endless invasion? Maryland Marine Notes, Mar-Apr 1996, Volume 14, No. 2. www.mdsg.umd.edu/MDSG/Communications/MarineNotes/Mar-Apr96/ (accessed August 1998).
- Grosholz, E.D. and G.M. Ruiz. 1996. Predicting the impact of introduced marine species: lessons from the multiple invasions of the European green crab *Carcinus maenas*. *Biological Conservation*. 78:59-66.
- Gosholz, E.D. and G.M. Ruiz. 1995. Spread and potential impact of the recently introduced European green crab, *Carcinus maenas*, in central California. *Marine Biology*. 122: 239-247.
- Gollasch, S. (in preparation). The importance of ship hull fouling as a vector of species introduction into the North Sea. Cited with permission from the author.
- Harbison, G.R. and S.P. Volovik. 1994. The ctenophore, *Mnemiopsis leidyi*, in the Black Sea: a holoplanktonic organism transported in the ballast water of ships. Pages 25-32 in Proceedings of the Conference and Workshop on Nonindigenous Estuarine and Marine Organisms (NEMO), NOAA, Seattle, Washington.
- Hine, M. 1995. Other mechanisms of marine organism transfer. Pages 95-101 in Ballast Water: A Marine Cocktail on the Move National Symposium, The Royal Society of New Zealand, Miscellaneous Series 30, Wellington, New Zealand.
- Kimmerer, W.J., Gartside, E. and J.J. Orsi. 1994. Predation by an introduced clam as the likely cause of substantial declines in zooplankton of San Francisco Bay. *Mar. Ecol. Progressive Series*. 113: 81-93.
- MDEQ (Michigan Department of Environmental Quality). 1999. Aquatic nuisance species handbook. Lansing, Michigan.
- Minchin, D. and J. Sheehan. 1995. The Significance of ballast water in the introduction of exotic marine organisms to Cork Harbour, Ireland. International council for the exploration of the sea. CM 1995/O:1. Theme session. Ballast Water: Ecological and Fisheries Implications. Aalborg, Denmark. 15p.

- Rainer, S.F. 1995. Potential for the introduction and translocation of exotic species by hull fouling: a preliminary assessment. Technical Report Number 1, Centre For Research on Introduced Marine Pests, Australia.
- Reise, K., S. Gollasch and W.J. Wolff. 1999. Introduced marine species of the North Sea coasts. *Helgolaender Meeresunters* 52: 219-234.
- Williams, E.H. Jr. and C.J. Sinderman. 1991. Effects of disease interactions with exotic organisms on the health of the marine environment. *Introductions and Transfers of Marine Species*. pp 71-77. Sea Grant, South Carolina.
- UNESCO. 1991. Programme on harmful algal blooms. IOC-SCOR Workshop on Programme Development for Harmful Algal Blooms. Workshop Report No. 80, Newport, Rhode Island. ioc.unesco.org/iochtm/w080/w080ww2.htm (accessed June 1999).

Assessing the Impact of Antifouling Compounds in the Marine Environment. Lessons to be Learned From the Use and Misuse of Biological Indicators of TBT Contamination

S.M. Evans and G.J. Nicholson

Dove Marine Laboratory
Department of Marine Sciences and Coastal Management
Newcastle University
Cullercoats
Tyne and Wear, NE30 4PZ
UK

e-mail: s.m.evans@ncl.ac.uk

ABSTRACT

The condition known as imposex in whelks has been used widely as a biological indicator of tributyltin (TBT) contamination in the marine environment. It has provided valuable information on the extent and impact of contamination. It has also been used successfully in monitoring changes in levels of contamination since regulations, limiting the use of TBT-based antifoulants to vessels >25 m in length, were introduced. However, its misuse has also generated misleading information. There have been at least four reasons for this. First, sampling has been biased on 'hot-spots' of contamination, giving a false impression of the severity of the problem. Second, imposex is not, as has often been assumed, a specific response to TBT. Third, insufficient attention has been given to the longevity and habits of indicator species. Fourth, predictions of extinctions of species, which have been based on assessments of imposex, have not been fulfilled. It is argued that, while biological indicators should play key roles in assessing the impacts of pollutants, rigorous protocols are needed.

I. INTRODUCTION

It is generally accepted the tributyltin (TBT) is the most effective biocide ever used in antifouling paints. TBT-based coatings have been used widely on yachts, mariculture structures and ocean-going vessels. They improve a ship's

performance by preventing the growth of fouling organisms on the hull, thereby reducing drag and concomitantly decreasing fuel consumption. This brings, not only enormous savings to the shipping industry, but also environmental benefits. Lower fuel consumption means reduced emissions of 'acid rain' and 'greenhouse' gases. An additional benefit is that effective antifouling prevents the transport of invasive (non-native) organisms on ship hulls. Such organisms can have enormous ecological and economic impacts, and pose major threats to marine ecosystems.

However, the use of TBT also has environmental costs. It leaches from the antifoulants into the water column and can cause damage to non-target organisms. It was, for example, held responsible for the near collapse of oyster farming in west France and for the demise of populations of dogwhelks in areas of high boating activity in southwest England during the 1980s. Not surprisingly, the use of these TBT-based paints was regulated in a number of countries, including Europe, USA, Canada, Australia and New Zealand. Several governments reacted by banning the use of TBT-based coatings on vessels <25m in length.

There is an obvious need to monitor the success of the regulations in reducing levels of TBT. However, there are difficulties in making, and interpreting the results of, chemical measures of TBT in the environment. This is for three reasons. First, TBT can be effective at concentrations which are close to the limits of detection. Second, there are sometimes large spatial and temporal variations in concentrations of TBT at fixed locations because it may be

released into the environment in pulses (e.g. from dry docks) which may be biologically harmful but may be missed by regular sampling. Third, the distribution of TBT in the environment is complex. It occurs at much higher levels in the surface microlayer and sediment than in the water column.

As a result of these difficulties, bioassays have been developed as indicators of TBT contamination. Imposex has been one of these. TBT causes imposex, in which male genitalia, a penis and vas deferens, become superimposed on the female's system. Gibbs *et al.* (1987) recommended two quantitative measures of imposex: (i) the relative penis size index (RPSI) which compares the size of the penis of the female with that of the male as a standard; and (ii) the vas deferens sequence index (VDSI), which recognises six stages primarily in the development of the vas deferens. Females at stages 1 - 4 of the vas deferens sequence (VDSI) are capable of breeding, but those at stages 5 and 6 are rendered sterile. Additional measures of the health and/or reproductive status of populations, suffering from imposex, have been made in some studies. They include assessments of abundance of whelks on the shore, adult sex ratios (populations with male-biased ratios are likely to have suffered from high female mortality) and the proportions of juveniles in populations (as indicators of juvenile recruitment and therefore breeding performance).

II. THE USE OF IMPOSEX AS A BIOLOGICAL INDICATOR OF TBT CONTAMINATION

The first detailed survey of imposex was of the dogwhelk *Nucella lapillus* in southwest England in the mid-1980s. Bryan *et al.* (1986) found that the condition, and presumably therefore TBT contamination, was severe in areas of high boating activity. In the most severe cases, there was female sterility and premature death. There was an absence of juveniles in some populations and, in the worst affected areas, the species became locally extinct. Further surveys showed that the condition was widespread. It was reported in surveys of *N. lapillus* in northeast England, Scotland, the British coast including the Isle of Man, the Netherlands, and the entire coastline of the North Sea. In other whelk species, it occurred in Canada, USA, Malaysia, Singapore, Indonesia, West Africa, New Zealand and Australia (Evans *et al.* 1995).

However, although TBT contamination was severe in the 1980s, regulations which prohibited the use of TBT-based antifoulants on small boats, have been highly successful in reducing ambient concentrations of TBT in the marine environment. Evidence has come from a number of different sources. These include the recovery of populations of oysters

and reduced concentrations of TBT in the water column, sediments and tissues of molluscs. Populations of whelks have shown three clear signs of recovery: reduced symptoms of imposex, increased abundance and fecundity and the recolonisation of some areas where they had become locally extinct.

The current situation is that commercial harbours, especially those with dry-docking and repair facilities, are still hot-spots of TBT contamination. However, the impacts of these remaining hot-spots are surprisingly localised. Gradients of sharply decreasing contamination have been described from dockyards, marinas and commercial harbours in Hong Kong, ports and fishing harbours in Iceland, marinas in Israel and a boatyard on the Isle of Cumbrae, Scotland (Table 1).

Table 1. Gradients of TBT in tissue and imposex (RPSI) in samples of dogwhelks *N. lapillus* across a boatyard entrance at Millport, Scotland.

Distance from boatyard entrance (metres)	TBT (ng/g dry weight)	RPSI
100	65	1.3
75	66	0.5
50	85	0.7
25	109	0.4
entrance (north)	369	12.9
entrance (south)	217	12.1
25	88	0.7
50	59	0.4
75	58	1.1
100	46	0.9

III. THE MISUSE OF IMPOSEX AS A BIOLOGICAL INDICATOR OF TBT CONTAMINATION.

However, there is not full accord. There have been some claims, based on surveys of imposex in whelks, that, despite the regulations, TBT contamination has continued to worsen. According to the North Sea Quality Status Report (1993), TBT pollution of the North Sea is so bad that it is likely to have catastrophic effects on the survival of sensitive species such as the dogwhelk. This assessment is based on an account of a survey by Harding *et al.* (1992) of imposex in *N. lapillus* in coastal areas of the North Sea and English Channel. An additional concern is that the open North Sea is contaminated. Ten Hallers-Tjabbes *et al.* (1994) found imposex in some common whelks *Buccinum undatum* from central and southern parts of the North Sea, and report that its severity correlated with the intensity of shipping in adjacent areas. Cadée *et al.* (1995) predicted that *B. undatum*

would eventually become extinct in the North Sea with the continued use of TBT-based antifoulants.

The results of these studies have been contradicted by more recent work. The predicted catastrophes have not occurred. Both *N. lapillus* and *B. undatum* are still abundant in the North Sea, and symptoms of imposex are generally mild (Evans *et al.* 1996; Nicholson & Evans 1997). However, these findings raise questions about the value of imposex as an indicator of TBT contamination. There appear to be at least four areas of concern:

(i) *Biased Sampling.* Sampling programmes have concentrated on hot-spots of contamination, such as drydocks, marinas and ports, giving a false impression of global contamination of the open seas and oceans. Where programmes have included areas of open coast adjacent to hot-spots, the impact has been local. Imposex-free populations, or those with mild symptoms, have been described within a few km of pollution at Loch Sween, Scotland, Wellington Harbour and Porirua Inlet, New Zealand, Port Philip Bay, Melbourne and Ambon Bay, Indonesia.

(ii) *The Causes of Imposex.* Imposex is not, as has often been assumed, entirely specific to TBT. Extensive studies by Bryan *et al.* (1986) appeared to establish that, apart from two related organotins, tri-*n*-propyltin and tetrabutyltin, TBT was the only compound to cause it in *N. lapillus*. The finding that copper, and even environmental stress, could induce it imposex in *Lepsiella vinosa* was therefore unexpected. Subsequently, it has been shown that triphenyltin, nonylphenol and exposure to faeces of seabirds can induce it in different species of whelks (Table 2).

(iii) *The Habits of Indicator Species.* Since imposex is irreversible, it tends to reflect conditions which have prevailed in the past rather than ambient ones. It is particularly difficult to interpret its significance in *B. undatum*, which is a long-lived, mobile species. It is sensitive to TBT during its juvenile development only. Since it can survive for 15 or more years, imposex may reflect conditions which prevailed a decade and a half previously, at some unknown location.

(iv) *The Use of Imposex to Indicate Fecundity.* Harding *et al.* (1992) reported that many populations of *N. lapillus* at sampling sites on the coast of Norway were sterile based on assessments of imposex. However, the expected extinctions have not occurred. The species is still common or abundant, and fecund, at these sites (Evans *et al.* 1996).

Table 2. The development of imposex in dogwhelks *N. lapillus* exposed to TBT and nonylphenol in the laboratory.

	Group			
	TBT controls	TBT	Nonylphenol controls	Nonylphenol
Sample size	40	40	40	40
Mean VDSI	1.7	3.7	1.9	3.1
Mean RPSI	4.2	15.7	1.4	14.1

IV. CONCLUSIONS

(i) Imposex in whelks is a useful biological indicator of TBT contamination. It can indicate the extent of contamination, its biological impact and can also be used for long-term monitoring of populations of whelks.

(ii) The condition must be used with caution. It can be caused by agents other than TBT so that confirmatory chemical measures are always needed. Care is needed in the design of sampling programmes and in the interpretation of imposex scores.

(iii) While biological indicators should play key roles in assessing the impacts of pollutants, rigorous protocols are needed.

V. REFERENCES

- Bryan, G.W., Gibbs, P.E., Burt, G.R. and Hummerstone, L.G. (1986) The decline of the gastropod *Nucella lapillus* around southwest England: evidence for the effects of tributyltin from anti-fouling paints. *Journal of the Marine Biological Association of the United Kingdom* **66**, 611-640.
- Bryan, G.W., Gibbs, P.E. and Burt, G.R. (1988) A comparison of the effectiveness of tri-*n*-butyltin chloride and five other organotin compounds in promoting the development of imposex in the dogwhelk, *Nucella lapillus*. *Journal of the Marine Biological Association of the United Kingdom*, **68** 733-744.
- Cadée, G.C., Boon, J.P., Fischer, C.V., Mensink, B.P., and ten Hallers-Tjabbes, C.C. (1995) Why the whelk (*Buccinum undatum*) has become extinct in the Dutch Wadden Sea. *Netherlands Journal of Sea Research* **34**, 337-339.
- Evans, S.M., Leksono, T. and McKinnell, P.D. (1995) Tributyltin pollution: a diminishing problem following legislation limiting the use of TBT-based antifouling paints. *Marine Pollution Bulletin* **30**, 14-21.
- Evans, S.M., Evans, P.M. and Leksono, T. (1996) Widespread recovery of dogwhelks, *Nucella lapillus* (L.) from tributyltin contamination in the North Sea and Clyde Sea. *Marine Pollution Bulletin* **32**, 263-269.
- Gibbs, P.E., Bryan, G.W., Pascoe, P.L. and Burt, G.R. (1987) The use of the dogwhelk (*Nucella lapillus*) as an indicator of TBT contamination. *Journal of the Marine Biological Association of the United Kingdom* **67**, 507-524.
- Harding, M.J.C., Bailey, S.K. and Davies, I.M. (1992) TBT imposex survey of the North Sea. UK Department of the Environment. Contract PECD 7/8214.
- Nicholson, G.J. and Evans, S.M. (1997) Anthropogenic impacts on the stocks of the common whelk *Buccinum undatum* (L.). *Marine Environmental Research* **44**, 305-314.
- North Sea Quality Report (1993) Man's impact on ecosystems. In: *North Sea Quality Status Report*, North Sea Task Force, Oslo and Paris, Olsen & Olsen, Fredensborg, pp. 80-98.
- Ten Hallers-Tjabbes, C.C., Kemp, J.F. and Boon, J.P. (1984) Imposex in whelks (*Buccinum undatum*) from the open North Sea: relation to shipping traffic intensities. *Marine Pollution Bulletin* **28**, 311-313.

An Overview of the Science and Regulation of TBT and the Potential for Future Liability for Contaminated Harbor Sediments

Michael A. Champ

Advanced Technology Research Project (ATRP) Corporation

P.O. Box 2439, Falls Church, Virginia 22042-3934, USA

Tel (703) 237-0505, Fax (703) 241-1278, E-Mail: <machamp@aol.com>

ABSTRACT

A draft Assembly Resolution prepared by the Marine Environmental Protection Committee (MEPC) of the International Maritime Organization (IMO) to propose a global ban on the use of organotins in antifouling paints was approved by the IMO Assembly at its 21st Regular Session (November 1999). In approving the Resolution, the Assembly agreed that a legally binding instrument (global convention – an international treaty) be developed by the Marine Environment Protection Committee that should ensure by January 1, 2003 a ban on the application of Tributyltin (TBT) based antifouling paints and January 1, 2008 as the last date for having TBT-based antifouling paint on a vessel. The Assembly also agreed that a Diplomatic Conference be held in 2001 to consider the adoption of the international legal instrument. Monitoring, policing, enforcement, fines and record keeping are yet to be defined. In addition, the MEPC has also proposed that IMO promote the use of environmentally safe anti-fouling technologies to replace TBT.

In the U.S., existing coastal zone, federal and state regulations have had a significant impact on reducing TBT levels, generally to well below the provisional water quality standard of 10 ng/L, and in bivalve tissues. Current environmental and marine and estuarine water concentrations are well below predicted acute TBT toxicity levels. Estimation of chronic toxicity effects using mean water TBT concentrations indicate that current levels would be protective of 95% of species. Analysis of allowable Daily Intake/Oral Reference Dose Values from market basket surveys and the NOAA National Status and Trends data suggest that

there is no significant human health risk from consuming seafood contaminated with TBT. Most of the data that exceeded these values were from areas of high TBT input from ports, harbors and marinas (commercial shipping, shipyards and drydock facilities) and sites of previous contamination. In the U.S., at this time, TBT environmental data and lack of acceptable alternatives does not justify a global ban for TBT.

This papers presents a discussion of: (1) Global environmental TBT concentrations and exceptions, (2) Comments on the scientific basis for the regulation of TBT, (3) The TBT scientific controversy, (4) Antifouling biocides and invasive species, and (5) The potential liability to shipping industry, shipyards and paint manufactures from the global ban on TBT in antifouling paints.

Keywords: Tributyltin, TBT, biofouling, antifouling marine coating, regulation, policy, toxicity, invasive organisms, liability and contamination of dredged materials.

GLOBAL ENVIRONMENTAL CONCENTRATIONS A DECADE AFTER REGULATION

In the United States, since the passage of the Antifouling Paint Control Act of 1988, the environmental concentrations of organotin compounds have declined (Seligman et al., 1990; Wade et al., 1991; U.S. EPA, 1991; Valkirs et al., 1991 and Huggett et al., 1992). Three national and regional monitoring programs in the U.S. have sampled for TBT since the passage of OAPCA in 1988. These are the U.S. National Oceanic & Atmospheric Administration's

(NOAA) National Status and Trends Monitoring (NS&T) Program, which was created in 1984 (see O'Connor, 1998). Overviews are presented in the Proceedings of the Coastal Zone 93 and the special issue of MPB Vol. 37 No. 1 (O'Connor and Pearce, 1998) and the papers there in. A second TBT monitoring program was the U.S. Navy Long-term Monitoring Program associated with Navy home ports and harbors (See U.S. Navy, and EPA, 1997). The third monitoring program is the consortium of tributyltin manufactures (ORTEPA) Long-term Monitoring Program contracted to Parametrix Inc., with results published in Cardwell et al., (1997; 1999); ORTEPA (1997, 1998). The results of these three national monitoring programs have been compared by Russell et al. (1998) who found that all of these programs have found declining environmental concentrations of TBT over time since the enactment of OAPCA in 1988. Water concentrations have declined 56% - 71%, sediment 47% -55% decline, and bivalve tissues 40%-82% within a few years. Mean TBT concentrations in water are generally below the current U.S. EPA marine chronic water quality criterion of 10 ng/L (Russell et al., 1996).

Studies have found that mean TBT surface water concentrations have significantly decreased in San Diego Bay, following legislative restriction on the use of organotin antifouling paints in California. Regression analysis of the San Diego data suggests that surface water concentrations would decrease by 50% in 8 to 24 months. It was found that sediment TBT concentrations in San Diego Bay did not reflect recent decreases in water column values and were variable among stations over time, and that tissue concentrations in *Mytilus edulis* have generally declined in San Diego Bay since February 1988 (significantly since April and July 1990), Valkirs et al. (1991).

Similar findings have been reported for the Chesapeake Bay by Huggett et al. (1992) for the Hampton, Virginia area of the Bay. Surface water samples analyzed after the passage of the Organotin Antifouling Paint Control Act (OAPCA) of 1988 in marinas and yacht clubs indicated that TBT concentrations had significantly decreased when compared to results of earlier studies by Huggett (1986, 1987) and Huggett et al., (1986), U.S. EPA Chesapeake Bay Program, (1987), and Hall

(1986; 1988); Hall et al. (1986; 1987).

The EPA Report to Congress (U.S. EPA, 1996) is a summary of the status of development of alternatives to TBT. The driving force is to develop an alternative to TBT, which could compete in the \$ 500 million per year total antifoulant paint market (C&E News, Oct 14, 1996). The TBT copolymer used in deep-ocean going vessels represents between 65-70 percent of this market. The goal is to develop a non-toxic (no effect on non-target organisms) antifoulant, which effectively inhibits the formation of biofilms and prevents biofouling. The major finding of the EPA 1996 Report (which has not been updated) was that "an alternative antifoulant as effective as TBT self polishing copolymer paints has not been found." They also reported that the principal alternatives today to TBT antifouling paints are copper-based. However, hulls treated with copper-based paints were reported to foul within 15 to 18 months due to formation of a "green layer" on the surface of the hull. The green layer is the reaction of copper to seawater, which results in the formation of a coating of insoluble cupric salts, preventing the release of copper from the paint underneath. Once the green layer is present, the antifoulant protection is no longer effective. Underwater hull scrubbing is required to remove the green layer and attached fouling organisms and with frequent scrubbing, the period of protection can be extended for up to 30-36 months depending on water temperatures. Revised estimates on fuel savings from the use of TBT by the Navy ranged from 18 to 22 percent of the total fuel consumption (U.S. EPA, 1996).

EPA has recently noted that noted that the use of copper is coming under increasing regulatory pressure with some coastal states restricting the amount of copper that may be discharged into local harbors during hull cleaning and washing. These regulations may impact the U.S. Navy's use of copper in antifoulant paints and leave the Navy without alternatives that meet their requirements. The Navy has held a workshop on the chemistry, toxicity and bioavailability of copper and its relationship to regulation in the marine environment to improve the scientific understanding of copper in the marine environment and attempt to develop a solid scientific basis for future approaches to copper regulation (Seligman and Zirino, 1998). In addition, the Navy has funded the development of in the water

cleaning systems for copper that also collect all waste and wastewater for treatment (Bohlander & Montemarano, 1997). It also should be noted that both Holland and Sweden have recently introduced regulations on antifouling paints for pleasure vessels containing copper as effective September 1, 1999. Canada has set the release rates of copper in antifouling paints at 40 mg/cm²/day. Copper is a potential toxin to marine organisms (Lewis and Cave, 1982; and Goldberg, 1992). It should also be noted that the U.S. Department of Defense and the U.S. Environmental Protection Agency have been working on the Uniform National Discharge Standards (UNDS) which will regulate the amount of biocidal discharges from antifouling coatings into the sea by December 2000, with the current release rates under consideration for copper less than the 40 mg/cm²/day. (see UNDS Website:

<http://206.5.146.100/n45/doc/unds/SITEMAP/ITEMAP.HTML>).

TBT concentrations in water, sediment, and biota have generally declined. Evans (1999b) has an excellent summary paper on the concentrations and environmental effects as a measure of the effectiveness of national regulations. TBT concentrations in surface marine waters have declined in Arcachon Bay, France (Alzieu et al., 1986, 1989) and in the UK (Cleary, 1991; Waite et al., 1991, 1996; Dowson et al., 1992, 1993a, 1993b and 1994) the USA (Valkirs et al., 1991; Huggett et al., 1992, 1996; and Uhler et al., 1993) and in the Gulf of Mexico from Wade et al., 1991; and Champ and Wade, 1996; Garcia-Romera et al., 1993) and Australia (Batley et al., 1992). Tissue concentrations in molluscs have declined (Valkirs et al, 1991; Wade et al., 1991; Champ and Wade, 1996; Waite et al., 1991, 1996; and CEFIC, 1994).

Exceptions to this general decline of TBT in bottom sediments have been reported as hot spots associated with ship channels, ports, harbors, and marinas in Galveston Bay (Wade et al., 1991), Hong Kong (Ko et al., 1995), the Netherlands (Ritsema et al., 1998), Iceland (Svavarsson and Skarphédinsdóttir, 1995) and in Israel (Rilov et al., 1999).

Oyster culture has recovered in France (Alzieu et al., 1986, 1989 and Alzieu, 1991 and 1996). In southern England, Waite et al. (1991; 1996; and Dyrinda, 1992)

reported improved oyster culture. For Australia, Batley et al. (1992) have reported improvements in oysters. Minchin et al. (1987) have reported improvements for scallops and Minchin, (1995) and for flame shells in Ireland.

The literature has also reported wide spread decline in Imposex and population recovery for dogwhelks (*Nucella* spp.): England (Evans et al., 1991; Douglas et al., 1993; Gibbs and Bryan, 1996a 1996b); Scotland (Evans et al., 1994 and 1996; and Nicholson et al., 1998); Ireland (Minchin et al., 1995); Norway (Evans et al., 1996); and Canada (Tester and Ellis, 1995; Tester et al., 1996).

COMMENTS ON THE SCIENTIFIC BASIS FOR THE REGULATION OF TBT

It is interesting to note, that the "movement" to regulate TBT based antifouling paints during the 1980's was initially based on "correlation" and "generality" type science (see Salazar and Champ, 1988). Peruse the bioassay discussions in White and Champ (1984), and see Evans et al. (1996) and Evans (1997 and 1999a; 1999b) for a discussion on Imposex. The Salazar and Champ (1988) paper was a preliminary review of the science that was prepared for an Oceans '88 conference proceedings to stimulate discussions. However, it was published about the same time that OAPCA was passed in the U.S. and interest in TBT and support for further research declined (Champ and Seligman 1996a). Fortunately this was not true on a global basis. Some of these concerns have been revisited and are discussed in a collection of papers reprinted and submitted by the paint industry to the MEPC by the Organotin Environmental Program Association (ORTEP, 1996, 1997 and 1998). Many of these points were discussed at the 1998 Annual Meeting of the American Chemical Society in Dallas (Rouhi, 1998) and in Champ (1998). In addition, papers were presented at the Oceans '99 Conference in Seattle (September, 1999) that discussed the science being used in the regulatory process (see Brancato and MacLellan, 1999; Cardwell et al., 1999; Damodaran et al., 1999; Evans, 1999c; Evans and Nicholson, 1999; Evans and Smith, 1999; MacLellan et al., 1999; and Toll et al., 1999). Several of these papers delineate problems with data quality and quantity, protocols and question the emphasis of the data and the information that is being utilized as a basis

for proposed additional regulation. *However, these points are moot if comparable and environmentally friendly alternatives to TBT are available and acceptable (Champ, 1998, 2000).*

The Scientific Controversy

Early concern was expressed that most of the evidence the regulatory process considered to be significant came from bivalve mollusks: (1) it was believed that mollusks were more sensitive than other animal groups to TBT, (2) Many bivalves have a cosmopolitan distribution and are commonly maintained in the laboratory, (3) filter-feeding bivalves may be more susceptible to TBT due to their feeding strategy, and (4) many bivalves have an economic importance in the commercial shellfish industry (Champ and Seligman, 1999b; 1999c). A significant and subtle distinction that needs to be kept in mind is the difference between the environmental impact of TBT on the shellfish industry and the environmental impact of TBT on natural shellfish populations. The point is that the effects on cultured shellfish do not necessarily demonstrate similar ecological effects in a typical natural situation. A second point is related to public definition of “acceptable” land use. It is difficult to appreciate being interested in culturing shellfish in areas adjacent to marinas and shipyards given their history of being defined as “polluted” due to acute and chronic contamination problems (Champ, 1983). Ports, harbors, and marinas are publicly approved marine land uses. These facilities are usually located in highly protected areas with low flushing rates, long water mass retention times, oil spills, high levels of contaminants, and high silt loads which are not optimum conditions for culturing filter-feeding bivalves.

In Europe, the critical evidence for the initial regulations in the mid 80’s, was associated with shell thickening in oysters (*Crassostrea gigas*) and imposex in dog-whelks (*Nucella lapillus*). In the U.S., the early critical evidence was associated with laboratory studies that reportedly demonstrated unacceptable effects on growth and development in oysters (*C. gigas*, *Ostrea edulis*) and clams (*Mercenaria*) (Champ, 1986). All of this evidence was based on only four species, a similar number of laboratory tests and field observations, generally unsupported by chemical

measurements and not published in peer reviewed journals. In general, the laboratory studies utilized questionable methodology and field studies lacked the necessary scientific rigor.

Bioaccumulation of TBT from Sediments

In what may become a classic regulatory textbook debate and case study, are the results of a 5-year study of TBT-contaminated sediments associated with an U.S. EPA Superfund site in Washington State. The issues unresolved are summarized in a U.S. EPA Region 10 Technical Memorandum (for addressing unanswered questions) that is entitled: “Topics Related to the Tributyltin Study at the Harbor Island Superfund Site, Seattle, Washington” (Keeley, 1999, Personal Communication). During EPA Superfund remedial investigations at the Harbor Island Site (Weston, 1994), TBT had been previously identified as a contaminant of potential concern due to elevated concentrations in the marine sediment (higher concentrations ranged from 10 to 50 ppm dw TBT).

Because there are no established Federal or State sediment quality guidelines or standards for evaluating TBT concentrations in sediment, the U.S. EPA formed an interagency working group to identify and evaluate approaches to deriving an effects-based sediment cleanup concentration for use at Superfund sites in Puget Sound, Washington. Most of the available literature presented toxicity of TBT for water, and only two studies (covering four species) evaluated toxicity associated with sediment concentrations of TBT (U.S. EPA, 1996a). The working group also proposed the calculation of an Apparent Effects Threshold (AET) value, which could be used as a sediment criteria for TBT, using available chemical (bulk sediment) and biological (sediment toxicity, benthic infauna) data from Puget Sound. The working group found that: (1) Existing Puget Sound data did not support a clear identification of an AET value for TBT; (2) A maximum no-effect concentration could often not be established because, in several cases, the highest sediment TBT concentration was associated with no biological effects and was also the highest concentration measured among all the stations sampled; (3) Good correlations were not found between bulk TBT sediment concentrations and laboratory toxicity and *in situ* benthic community responses; and

(4) Based on an evaluation of available information, "bulk sediment concentrations of TBT were a poor predictor of bioavailable TBT" (U.S. EPA 1996a). Further, the working group recommended, based on a general understanding of chemical partitioning and the lack of observed relationships between bulk sediment TBT and adverse ecological effects, that when TBT is a contaminant of concern in sediment, pore water concentrations of TBT should be measured, and toxicity testing or bioaccumulation testing (*in situ* or laboratory) be conducted to confirm the ecological significance of concentrations measured in pore water. The working group did not provide recommendations for specific bioaccumulation test species, because it was believed that additional work needed to identify the most appropriate species (ESI, 1999a).

In a series of subsequent TBT related studies, a consortium of Harbor Island waterfront property owners (the Port of Seattle, Lockheed Martin Corporation and Todd Shipyards Corporation) funded a study to evaluate the bioavailability of and the potential effects associated with TBT in sediments at the Superfund site. The overall purpose of this study was to develop a site-specific, effects-based TBT tissue trigger concentration that could be used to determine the need for remediation of TBT-contaminated sediments. In this study, effects considered relevant for the development of a site-specific tissue trigger value were mortality; reduced growth; and reproductive impairment. The normal TBT effects cited in the literature, such as bivalve shell thickening or induction of (early stage) imposex or intersex in meso- and neogastropods, were not appropriate in this evaluation, because (1) these biological responses do not have established connection to population-level effects, and (2) there is a lack of suitable habitat at the site for the species (oysters, mesogastropods, and neogastropods) typically affected by shell thickening, imposex and intersex. The study site is a deep (-30 to -60 ft mean lower low water), industrialized channel of subtidal sediments within the Duwamish River Estuary. Very little intertidal habitat is available, due to extensive channelization and dredging of the waterway, and no commercial or recreational shellfish beds occur. In addition, gastropods typically are not a large component of the benthic community at the site, and mesogastropods and neogastropods are very limited in abundance (ESI 1999a). The study was performed

in accordance with a Sampling and Analysis Plan (SAP), prepared by ESI (1998) that was reviewed and commented on by all reviewers prior to its approval by U.S. EPA, and resultant data from the TBT study were determined to be of high quality by EPA (ESI, 1999b).

The evaluation of TBT sediments from the Harbor Island sediments was conducted in two studies. First, a TBT literature review was conducted to identify global paired tissue residue and effects data for marine invertebrates and fish (ESI 1999a). The tissue residue data were used to estimate a site-specific, effects-based tissue trigger concentration for TBT (ESI 1999a). Second, sediment samples were collected throughout the study site for chemical and biological testing (ESI 1999b). TBT concentrations were measured in bulk sediments and pore water samples; a subset of sediment samples collected was used for bioaccumulation testing. With approval from all involved agencies and consistent with national guidance, bioaccumulation testing was conducted to determine site-specific exposures to two marine invertebrate species: (1) a bivalve (*Macoma nasuta*) and (2) a polychaete (*Nephtys caecoides*). No approved marine sediment toxicity bioassay protocols for test species that have demonstrated sensitivity to TBT were available (U.S. EPA, 1996a), so no toxicity testing was conducted. The resulting tissue TBT concentrations were then compared to the effects-based trigger concentration derived from the literature (ESI 1999b; Keeley, Personal Communication).

Results of this study were that the survival of the laboratory test organisms was high, and the lipid content of the organisms exposed to test sediments was similar to controls, which suggest to many of the projects reviewers that the organisms were in good physiological health during the exposure period. A site-specific tissue trigger (3 mg/kg DW TBT) was estimated (Meador, 2000) for the study site for evaluating bioaccumulation data from the study area, and for the 20 stations sampled and tested at the site, none of the tissue samples from the bioaccumulation tests exceeded the tissue trigger value of 3 mg/kg DW TBT. Thus, no cleanup of TBT sediments was recommended. The value of 3 mg/kg DW TBT, which was derived from paired tissue residue effects data in the literature, is estimated to be the tissue residue

associated with reduced growth in a number of invertebrate species. The level is however, very similar to the overall geometric mean of paired effect/no-effect data and the estimate of a sublethal effects level based on a multi-species acute-to-chronic effects ratio for the study area.

The development of tissue residue effects thresholds is part of EPA's overall strategy for management of specific contaminants in sediments in the US rivers and estuaries. The lack of TBT bioaccumulation from sediments in these studies is not understood, creating more unanswered questions and confusion in the data and suggests that further studies are needed prior to the development of a protocol for estimating TBT tissue level triggers for regulatory use. Results from the study also found that TBT tissue concentrations were most strongly correlated with dw-sediment and carbon-normalized sediment TBT concentrations, and there were weak correlations with filtered and unfiltered pore water TBT concentrations. If there is no relationship between levels in sediments and bioaccumulation levels in tissues, then the TBT in the sediments has been shown to not be bioavailable. For the determination of ocean dumping for dredged materials, the decision has to do with whether a species has accumulated more than 3 mg/kg DW TBT.

After completing the Harbor Island TBT bioaccumulation studies, the U.S. EPA (1999) prepared a Technical Memorandum to address topics of interest identified by EPA and other agency reviewers on issues related to the findings presented in the above study (ESI, 1999c). Several scientists reviewing the results of the Harbor Island studies had a difference of opinion in the interpretation of the results. Some reviewers of ESI (1999b) indicated that the measured TBT bioaccumulation in test organisms for this project was less than they would have expected from the measured sediment and pore water TBT concentrations in site samples. This concern was based in part on a comparison of the bioaccumulation test results with studies reported in the literature and with other similar studies performed in the general Harbor Island area. Some reviewers suggested that several test parameters (e.g., species selection, exposure regime of tests, organism health) might have influenced the results.

Salazar and Salazar (1999a, b, in preparation) in reviewing the Harbor Island bioaccumulation studies believe that the major lesson learned from this study and their separately conducted caged bivalve bioaccumulation studies are that lab tests don't predict nature very well, or adequately consider equilibrium and energetics. They have listed the following specific lessons learned from their research on TBT uptake by mussels that: (1) Lab tests generally over-estimate toxicity; (2) Lab tests generally under-estimate bioaccumulation; (3) Bivalves are sensitive test species; (4) Exposure period should be determined by equilibrium; (5) Growth rate affects bioaccumulation potential; (6) Quantifying health is important in data interpretation; and (7) Tissue chemistry can be used to predict effects. Salazar and Salazar (1987; 1989; 1996) and Salazar et al. (1987) have found that survival and growth effects of TBT were over-estimated based on laboratory tests and mesocosm studies. They placed caged mussels at the seawater intake to test tanks and found that growth rates were about 4 times faster outside the test tanks compared to growth in the control tanks.

In the Harbor Island studies, the issue is the interpretation of the tissue chemistry data and Salazar and Salazar (1996a b, in preparation) believe that, even though the U.S. EPA followed all state and national guidance and accepted state-of-the-art testing protocols, they believe that laboratory exposures have under-estimated bioaccumulation levels due to animal health from test conditions. Meador (Personal Communication) suggests that *Macoma* in these tests were more than likely ventilating clean overlying water, reducing its exposure to TBT. Generally speaking, bivalves are extremely sensitive to food and flow rate and growth rates seldom if ever achieve the growth rates of animals in nature. Laughlin (1996) reported that BCF is related to growth rate and that the highest growth rates were associated with the highest BCFs. Laughlin referred to this as the concentration dependence of TBT accumulation. Widdows et al. (1990) found that the operative mechanism is that growth rate is also related to filtration rate. Laughlin (1996) measured BCFs of only about 5,000 compared to an average of about 30,000 from Salazar (1989); and Salazar and Salazar (1996) transplanted mussels, suggesting that Laughlin's animals may have been under severe stress.

The 28 day exposure bioaccumulation tests in the Puget Sound Studies with the marine bivalve *Macoma nasuta* (which is a facultative feeder – both filter feeding and deposit feeder) did not reach steady state, when the test was extended to 45 days, and the results may have reflected test conditions in which *Macoma* may have been stressed. Originally, EPA proposed modifying the test procedure in accordance with Test Sediment Renewal (EPA Guidance Manual on Bedded Sediment Bioaccumulation Tests (EPA/600/R-93/183) which recommends complete sediment renewal for test longer than 28 days. Bruce Boese (EPA Newport Laboratory and an author of the manual) suggests that the primary reason for performing sediment renewal was to give the animals more “food”. For the Harbor Island tests, it was decided to add 0.5 cm of sediment to the test chambers every 7 to 10 days for the entire test (overlaps weekends). Questioned in the study was also the use of lipid content at the beginning and end of the test was considered as an endpoint to evaluate potential stress on the test organisms. Boese (Personal Communication) felt that lipid content of *Macoma* does not give you any information about the health of *Macoma*, and that loss/gain of lipids is primarily related to reproduction.

Laboratory bioassays have become an environmental test industry and big business in making regulatory decisions. Their simplicity, cost and reproducibility are very attractive to regulatory policy and decision-makers. However, their scientific value or merit has been repetitively questioned. White and Champ (1983) addressed this issue of “The Great Bioassay Hoax” and Salazar (1986) asked similar questions regarding the application of traditional laboratory toxicity tests to assessments of TBT. Salazar and Salazar have raised these questions to a higher level of sophistication but the old problems still remain. Scientists in the bioassay testing business hesitate to challenge an accepted regulatory test, because of a lack of a replacement, and the process to get one accepted, but still need to strive to develop standardized tests that validate and represent what an organism actually experiences in the environment.

Salazar and Salazar (1999a, b, in preparation) also feel that the other interesting issue here is that they believe that the *Macoma* bioaccumulation test may be flawed for the following reasons: (1) since the ASTM

protocols do not require any effects measurements, one can never be sure of the health of the test organisms, (2) the largest and slowest-growing animals generally have the lowest tissue concentrations in transplant studies, and (3) people tend to forget that *Macoma* is a facultative deposit feeder, and can either filter- or deposit-feed. Recent summary papers have reported that many benthic invertebrates are quite plastic in their feeding mode and readily shift back and forth from filter- to deposit-feeding depending on local environmental conditions and available food and can select between clean and filtered seawater and highly contaminated sediment.

Langston and Burt (in preparation) found that concentrations in tissues of *Scrobicularia plana* (a deposit feeding clam) in the UK reached equilibrium in tissues after 40 days of exposure. They also reported that sediments are an important vector for TBT uptake in deposit-feeding clams. They also concluded that it is particulate rather than desorbed TBT, which is most significant. Laughlin (1996) reports that bioaccumulation factors appear to be high, but field studies, in particular, have not necessarily carefully characterized the route of uptake (water or food).

Salazar and Salazar (1999) have found numerous examples where bivalves have been the most sensitive test species. Their predicted tissue burden for effects in mussels is an order of magnitude lower than that for amphipods based on the work of Meador (1997 and references cited there in) and others. Theory suggests that tissue concentrations for effects should be relatively constant across species and that appears to be true for particular endpoints like growth. The problem is that it is relatively difficult to measure growth rate in an amphipod. The difference in sensitivity is due to the growth rate endpoint in bivalves and the mortality endpoint in amphipods which theory suggests is about an order of magnitude different (McCarty, 1991; McCarty and Mackay, 1993). An additional problem with most laboratory tests is that they were not originally selected and standardized by equilibrium kinetics and steady state.

Amphipod tests are routinely conducted for only 10 days, even though Meador (1997, 2000) has found that it takes about 45 days to reach chemical equilibrium or steady state. This may explain why there appears to

ANTIFOULING BIOCIDES AND INVASIVE SPECIES

be a disconnect between sediment chemistry, laboratory toxicity tests, and benthic community assemblages using the sediment quality triad. This has led to suggestions of using tissue chemistry to predict effects (McCarty, 1991; McCarty and Mackay, 1993). Subsequently Salazar and Salazar (1991; 1998; and Submitted) developed the exposure-dose-response triad that relies on tissue chemistry to make the link between the various effects endpoints. This relates to Salazar's point of growth rate affecting bioaccumulation potential. Sick and dying animals do not accumulate much TBT, which is why it is essential to confirm the health of the test animals.

With TBT data, they have been able to predict where effects will occur based on where the relationship between water or sediment and tissue TBT begins to change. This was first demonstrated in a graph published in Salazar and Salazar (1996) that plotted the relationship between water and tissue TBT. They found that grouping the data above 105 ng/L gave one regression and at 105 ng/L or lower that it gave a very different regression. The Salazar's recently replotted the Langston and Burt (1991) data and found exactly the same relationship, which Langston concurred. With Langston and Burt's data, they found effects in *Scrobicularia* to occur between 0.1 to 0.3 ug/g TBT dry weight in sediment, which agrees with Meador's data for effects on the polychaete *Armandia brevis* (Meador and Rice, In Press). The Salazar's summarized their findings in a paper presented at the SETAC (1999) meeting in Philadelphia. This paper is being expanded to emphasize the significance of field data over laboratory data in predicting effects and will be submitted to the Journal of Marine Environmental Research. They concluded that these data sets: (1) supports their hypothesis that one can predict the concentrations where effects will begin to occur based on the relationship between external concentrations and tissue burdens; (2) demonstrates that the concept may work for both water and tissue; and (3) suggests that tissue burdens associated with effects (acute 10X > chronic) are relatively constant across marine organisms.

Recent research has suggested that hull biofouling will likely play a much greater role in introduction of invasive (exotic) species following a global ban on the use of TBT in antifouling paints. The 10th International Congress on Marine Corrosion and Fouling (February, 1999) in Melbourne Australia, included two special sessions on invasive species transported on vessel hulls. Stephan Gollasch, from the Institute for Marine Sciences in Germany gave a keynote address on the importance of ship hull fouling as a vector of species introductions into the North Sea. Dan Minchin presented a paper on data and information from Ireland and Mary Sue Brancato presented data from the U.S. (see also Brancato and MacLellan, 1999). Historically invasive species from the hulls of ships has been mostly an exotic marine algae and plants problem due to the speed and size of ships and water quality in ports.

Minchin estimated that 1.8 million marine organisms could exist on the hull of a severely biofouled vessel (Minchin, Personal Communication). However, after the introduction and use of TBT in the early 70's, fouling on hulls was not considered a significant source problem for invasive species, because in general hulls were cleaner. Considering the coincidence of global climate fluctuations and the proposed global ban on the use of TBT, invasion of species via the biofouling community on fouled hulls of ships may eventually constitute a greater threat than those in ballast water (Minchin and Sheehan, 1999).

Minchin is also concerned that there is a correlation between ship hull hitchhikers and water temperature changes. Ships pass through rapid water temperature fluctuations while entering harbors and channels and ports from the open ocean. These sudden temperature swings may initiate spawning triggering invasive species introduction in ports and port channels. Populations could easily become established in the invaded U.S. port because the U.S. Clean Water Act has greatly cleaned up (reduced pollution) U.S. ports

over the years. In the past, the level of contamination in most ports has reduced the probability of the invading organism becoming established. With the movement to clean up ports and harbors world wide, the risk of introduction has greatly increased. Minchin believes that IMO must have available replacements that are as effective as TBT, in providing the same degree of protection to coastal waters from invasive species as TBT has for the past three decades. To ban it, we would face serious introduction of invasive species in the temperate environments. Their environmental impacts include changes in biodiversity, food webs, trophic levels competition, and the introduction of disease organisms and parasites.

It has been estimated that over 6000 species have been introduced in the U.S. The introduction of the lamprey eel and zebra mussel in the Great Lakes are examples of major invasive species that have had significant impact on U.S. aquatic ecosystems. The zebra mussel has had detrimental effects on lakeside piers, industrial facilities and public beaches. Another example the European Green Crab (*Carcinus maenas*) has the potential to impact the \$20 million dollar crab industry in the State of Washington alone (Brancato, 1999). Additional examples of invasive species are the Toxic Japanese dinoflagellates and the Northern Pacific sea star, which have infested New Zealand and Australia. The American comb jellyfish has greatly impacted the anchovy industry in the Black Sea.

In his keynote address at the 10th International Congress on marine Corrosion and Fouling, Stephan Gollasch reported on historical studies of invasive species in the North and Baltic Seas and compared vectors of introduction including ballast water and hull fouling from 200 ships. In the 1992 to 1995 time frame, Gollasch reported that most of the non-native species with the highest potential for establishment were from fouled hulls, with 53% of the marine exotic species found in the North Sea introduced by shipping and 98% of the hulls sampled revealed non-native species (Reise et al., 1999). Of the species connectable to shipping, 66% were introduced from the hull, 34% from ballast tanks. Gollasch, the second author of Reise et al. (1999) paper is also a scientific advisor and member of the German delegation for the ballast water working group at IMO's MEPC 43. He believes that IMO should consider the hull fouling dilemma in

its assessment of the ban of TBT and balance the risk of introduction of invasive species harming local ecosystems with the environmental risks of TBT on non-target species in their decision-making process. He has found that most of the species of high concern are transported in ballast water including cholera bacteria and phytoplankton algae causing harmful algal blooms, but he believes the risk of species introduction from ships hulls is increasing and without TBT it could be even worse (Gollasch, 1999, personnel communication).

TBT CONTAMINATION OF SEDIMENTS IN PORTS AND HARBORS

If TBT is banned by international treaty as proposed by MEPC 42, the future cost of removal of dredged material from harbors and waterways will probably increase significantly. An example of how regulation can increase disposal of dredged material costs is seen in the two alternatives available to the Port of NY/NJ for immediate disposal of dredge spoils. The Mud Dump Site (located 3 miles offshore in the open waters at the mouth of the harbor) has been operational for many decades and has been the traditional disposal area and can accept Category I dredged materials. Category II and III contaminated "spoils" have to be disposed of at an upland hazardous waste disposal facility, however, from 1977 to 1991, 90% of all NY/NJ dredge spoils were tested and classified Category I and only 1 to 2 % were Category III. However, in 1991 the US EPA replaced the existing tests in the NY region and added new bioassay testing which altered Category I, II, and III determinations.

For Category II and III dredged material, the currently available alternative is upland disposal at a hazardous materials storage facility and none are available in the near vicinity. Howland Hook Terminal in Staten Island shipped 150,000 yd³ of sediment via barge and rail to Utah at a cost of \$17 million or over \$110/yd³. Traditional fees for dumping dredge materials at the Mud Dump Site are in the area of \$10/yd³.

If TBT ("as perhaps the most toxic substance ever deliberately introduced to the marine environment by mankind") is banned by an international convention (it will be the first chemical by name to have its own convention or treaty) it could then be considered equal

or more hazardous than Category III compounds. As such it might greatly increase the cost of disposal of dredged materials from most ports and harbors that are contaminated with TBT, because of its persistence and its universal distribution in bottom sediments of ports and ship channels.

An additional concern for the paint companies, shipyards and shipping industry may be that in the future that they have bear the liability for cost contained dredging. It may be that the liability for the additional or special costs of dredging and disposal of TBT contaminated dredged materials from ports and ship channels might revert back in the courts to sources such as have the costs of health settlements from smoking in the courts. The impact on TBT contamination in port sediments on future shipping and port development is significant, for example, plans to dredge the Tyne in Newcastle (UK) may be abandoned, because of extremely high TBT concentrations in the river sediments, and the concern that organotins will desorb from particles on agitation during dredging and disposal of dredge material at sea (Mark G.J. Hartl, Personal Communication). Approval for dredging is pending on the outcome of a survey being conducted by CEFAS, Burnham On Crouch.

REFERENCES CITED

- Alzieu, Cl., J. Sanjuan, J. Deltreil and M. Borel. 1986. Tin contamination in Arcachon bay: effects on oyster shell anomalies. *Marine Pollution Bulletin*. **17**:494-498.
- Alzieu, Cl., J. Sanjuan, P. Michell, M. Borel and J.P. Dreno. 1989. Monitoring and assessment of butyltins in Atlantic coastal waters. *Marine Pollution Bulletin*. **20**(1):22-26.
- Alzieu, Cl. 1991. Environmental problems caused by TBT in France: Assessment, regulations, prospects. *Marine Environmental Research*. **32**:7-17.
- Alzieu, C., P. Michel, I. Tolosa, E. Bacci, L.D. Mee and J.W. Readman. 1991. Organotin compounds in the Mediterranean: a continuing cause for concern. *Marine Environmental Research*. **32**(1-4):2261-270.
- Batley, G.E., C.I. Brockbank. And M.S. Scammell. 1992. The impact of banning of tributyltin-based antifouling paints on the Sydney rock oyster, *Saccostrea commercialis*. *Sci. Total Environ.* **122**:301-314.
- Boese, 1999. Personal Communication. USEPA Newport Laboratory, Oregon.
- Bohlander. G.S. and J.A. Montemarano. 1997. Biofouling, fleet maintenance and operational needs. *Naval Research Reviews*. (ONR) Vol. **XLIX**: 9-18
- Brancato, M.S. and D. MacLellan. 1999. Impacts of invasive species introduced through the shipping industry. Proceedings Oceans '99 International Symposium on the Treatment of Regulated Discharges from Shipyards and Drydocks. Marine Technology Society. Washington, D.C. This Volume.
- Brancato, M.S. 1999. Personal Communication. Parametrix, Inc., 5808 Lake Washington Boulevard N.E., Suite 200. Kirkland, Washington 98033. Tel. (425) 822-8880. Fax (425) 889-8808.
- Cardwell, R., M.S. Brancato, J. Toll, D. DeForest and L. Tear. 1997. Aquatic ecological risks posed by Tributyltin in U.S. surface waters: Pre-1989-1997 Data. *Environmental Toxicology and Chemistry*. **18**(3):567-577.
- Cardwell, R., M.S. Brancato, J. Toll, D. DeForest and L. Tear. 1999. Aquatic ecological risks posed by Tributyltin in U.S. surface waters: Pre-1989-1997 Data. Proceedings Oceans '99 International Symposium on the Treatment of Regulated Discharges from Shipyards and Drydocks. Marine Technology Society. Washington, D.C. This Volume.
- CEFIC (European Chemical Industry Council). 1992. TBT copolymer antifouling paints: the facts. Document MEPC 33/INF.14 for the 33rd meeting of the Marine Environment Protection Committee of the International Maritime Organization. London.
- CEFIC (European Chemical Industry Council). 1994. Use of organotin compounds in anti-fouling paints. Results of TBT monitoring studies. Document MEPC 35/17 for the 35th meeting of the Marine Environment Protection Committee of the International Maritime Organization. London.
- CEFIC (European Chemical Industry Council). 1996. Harmful effects on the use of antifouling paints for ships: A review of existing antifouling paints and the development of alternative systems. Document MEPC 36/14/4. for the 36th meeting of the Marine Environment Protection Committee of

- the International Maritime Organization. London.
- Champ, M. A. 1983. Etymology and Use of the Term "Pollution." *Canadian Journal of Fisheries and Aquatic Science*. 40(Suppl. 2):5-8.
- Champ, M.A. 1986. Introduction and overview. Proceedings Oceans '86 Organotin Symposium. Marine Technology Society. Washington, D.C. Vol. 4:i-viii.
- Champ, M.A. and F.L. Lowenstein. 1987. TBT: The dilemma of hi-technology antifouling paints. *Oceanus*. Woods Hole Oceanographic Institution. 30(3):69-77.
- Champ, M.A. and L.W. Pugh. 1987. Tributyltin antifouling paints: Introduction and overview. Proceedings Oceans '87 International Organotin Symposium. Marine Technology Society. Washington, D.C. Vol. 4:1296-1308.
- Champ, M.A. and P.F. Seligman. 1996a. *Organotin: Environmental Fate and Effects*. (Eds) Chapman & Hall. London. 674p.
- Champ, M.A. and P.F. Seligman. 1996b. An Introduction to organotin compounds and their use in antifouling coatings. Chapter 1. *In: Organotin: Environmental Fate and Effects*. Champ and Seligman (Eds). Chapman & Hall. London. pp. 1-26.
- Champ, M.A. and P.F. Seligman. 1996c. Research information requirements associated with the environmental fate and effects of organotin compounds. Chapter 29. *In: Organotin: Environmental Fate and Effects*. Champ and Seligman (Eds). Chapman & Hall. London. pp. 601-614.
- Champ, M.A. and T.L. Wade. 1996. Regulatory policies and strategies for organotin compounds. Chapter 3. *In: Organotin: Environmental Fate and Effects*. Champ and Seligman (Eds). Chapman & Hall. London. pp. 55-94.
- Champ, M.A. 1998. The tributyltin antifouling paint controversy. *Sea Technology* 39(7):113.
- Champ, M.A. 1999a. The need for the formation of an independent, international marine coatings board. *Marine Pollution Bulletin*. 38(4):239-246.
- Champ, Michael A. 1999b. Incorporating Good Environmental Science in the Current Organotin Regulatory Debate. Editorial, Lessons Learned. SETAC November Newsletter.
- Champ, M.A. 2000. The Coating Conundrum. Editorial. Maritime Reporter and Engineering News. (January). Vol. 1, pp 46-48.
- Champ, M.A. (In Press for 2000). A Review of Organotin Regulatory Strategies, Pending Actions, Related Costs and Benefits. *Science of the Total Environment*. 75p.
- Cleary, J.J. 1991. Organotin in the marine surface microlayer and sub-surface waters of Southwest England: relation to toxicity thresholds and the U.K. environmental quality standard. *Marine Environmental Research*. 32(1-4):213-222.
- Damodaran N., J. Toll, M. Pendleton, C. Mulligan, D. DeForest, M. Kluck, M.S. Brancato and J. Felmy. 1999. Cost Analysis of TBT Self-Polishing Copolymer Paints and Tin-Free Alternatives For Use On Deep-Sea Vessels. Proceedings Oceans '99 International Symposium on the Treatment of Regulated Discharges from Shipyards and Drydocks. Marine Technology Society. Washington, D.C. This Volume.
- Douglas, E.W., S.M. Evans, C.L.J. Frid, S.T. Hawkins, T.S. Mercer, and C.L. Scott. 1993. Assessments of imposex in the dogwhelk (*Nucella lapillus*) and tributyltin along the north-east of England. *Invertebrate Reproduction & Development*. 23:243-248.
- Dowson, P.H., J.M. Bubb, and J.N. Lester. 1992. Organotin distribution in sediments and waters of selected east coast estuaries in the UK. *Marine Pollution Bulletin*. 24:492-498.
- Dowson, P.H., J.M. Bubb and J.N. Lester. 1993a. Temporal distribution of organotins in the aquatic environment: Five years after the 1987 UK retail ban on TBT based antifouling paints. *Marine Pollution Bulletin*. 26(9):487-494.
- Dowson P.H., J.M. Bubb, J.N. Lester. 1993b. Depositional profiles and relationships between organotin compounds in freshwater and estuarine sediment cores. *Environmental Monitoring & Assessment*. 28:145-160.
- Dyrynda, E.A. 1992. Incidence of abnormal shell thickening in the Pacific oyster *Crassostrea gigas* in Poole Harbour (UK), subsequent to the 1987 TBT restrictions. *Marine Pollution Bulletin*. 24:156-163.
- ESI (EVS Solutions Inc). 1998. Waterway Sediment Operable Unit, Harbor Island Superfund Site: Sampling and analysis plan for TBT study. Prepared for the Port of Seattle, Lockheed Martin and Todd Shipyards for submittal to EPA Region

10. Seattle, WA. EVS Solutions, Inc. Seattle, WA. 30p. 5 Appendices.
- ESI (EVS Solutions Inc). 1999a. Waterway Sediment Operable Unit, Harbor Island Superfund Site: Review of Tissue Residue Effects Data for Tributyltin, Mercury, and Polychlorinated Biphenyls. Prepared for the Port of Seattle, Lockheed Martin, and Todd Shipyards for submittal to EPA Region 10. Seattle, WA. EVS Solutions, Inc. Seattle, WA. 37p.
- ESI (EVS Solutions Inc). 1999b. Waterway Sediment Operable Unit, Harbor Island Superfund Site: Tributyltin in marine sediments and the bioaccumulation of tributyltin: combined data report. Prepared for Port of Seattle, Lockheed Martin Corporation, and Todd Shipyards Corporation. EVS Solutions, Inc. Seattle, WA. 42p. 7 Appendices.
- ESI (EVS Solutions Inc). 1999c. Waterway Sediment Operable Unit, Harbor Island Superfund Site: Technical Memorandum: Topics related to the TBT field study at the Harbor Island Superfund Site, Waterway Sediment Operable Unit. Prepared for the Port of Seattle, Lockheed Martin Corporation, and Todd Shipyards for submittal to USEPA Region 10 Seattle, WA. EVS Solutions, Inc. Seattle, WA. 15p.
- Evans, D.A. and R.J. Huggett. 1991. Statistical modeling of intensive TBT monitoring data in two tidal creeks of the Chesapeake Bay. *Marine Environmental Research*. **32**(1-4):169-186.
- Evans, S.M., A. Hutton, M.A. Kendall, and A.M. Samosir. 1991. Recovery of dogwhelks, *Nucella lapillus* (L.) suffering from imposex. *Marine Pollution Bulletin*. **22**:331-333.
- Evans, S.M., S.T. Hawkins, J. Porter, A.M. Samosir. 1994. Recovery of dogwhelk populations on the Isle of Cumbrae, Scotland following legislation limiting the use of TBT as an antifoulant. *Marine Pollution Bulletin*. **28**:15-17.
- Evans, S.M., T. Leksono and P.D. McKinnel. 1995. Tributyltin pollution: a diminishing problem following legislation limiting the use of TBT-based antifouling paints. *Marine Pollution Bulletin*. **30**(1):14-21.
- Evans, S.M., P.M. Evans and T. Leksono. 1996. Widespread recovery of dogwhelks, *Nucella lapillus* (L.) from Tributyltin contamination in the North Sea and Clyde Sea. *Marine Pollution Bulletin*. **32**(3):263-269.
- Evans, S.M. 1997. Assessments of Tributyltin Contamination from 1986 until 1997. The misuse of imposex as a biological indicator of TBT pollution. *In: Harmful Effects of the Use of Antifouling Paints for Ships*. Stewen (ed). Organotin Environmental Programme Association (ORTEP Association). Witco GmbH, Germany. pp. 51-56.
- Evans, S.M. 1999a. Tributyltin pollution: the catastrophe that never happened. *Marine Pollution Bulletin*. **38**(8):629-636.
- Evans, S.M. 1999b. TBT or not TBT?: That is the question. *Biofouling*. **14**(2):117-129.
- Evans, S.M. 1999c. The environment: our joint responsibility. Proceedings Oceans '99 International Symposium on the Treatment of Regulated Discharges from Shipyards and Drydocks. Marine Technology Society. Washington, D.C. This Volume.
- Evans S.M., and R. Smith. 1999. The effects of regulating the use of TBT-based antifouling paints on TBT contamination. Proceedings Oceans '99 International Symposium on the Treatment of Regulated Discharges from Shipyards and Drydocks. Marine Technology Society. Washington, D.C. This Volume.
- Evans S.M. and G.J. Nicholson. 1999. Assessing the impact of antifouling compounds in the marine environment. Lessons to be learned from the use and misuse of biological indicators of TBT contamination. Proceedings Oceans '99 International Symposium on the Treatment of Regulated Discharges from Shipyards and Drydocks. Marine Technology Society. Washington, D.C. This Volume.
- Fox, T.J., T. Beacham, G.C. Schafran, and M.A. Champ. 1999. An advanced technology for removing TBT from shipyard wastewaters. Proceedings Oceans '99 International Symposium on the Treatment of Regulated Discharges from Shipyards and Drydocks. Marine Technology Society. Washington, D.C. This Volume.
- Garcia-Romero, B., T.L. Wade, G.C. Salata and J.M. Brooks. 1993. Butyltin concentrations in oysters from the Gulf of Mexico from 1989 to 1991. *Environmental Pollution*. **81**:103-111.
- Gibbs, P.E. and G.W. Bryan. 1996a. Reproductive failure in the gastropod *Nucella lapillus* associated

- with imposex caused by tributyltin pollution: a review. In *Organotin, Environmental Fate and Effects* Champ and Seligman (eds). Chapman and Hall. London. pp. 259-280.
- Gibbs P.E. and G.W. Bryan. 1996b. TBT-induced imposex in neogastropod snails: masculinization to mass extinction. In: *Tributyltin: Case Study of an Environmental Contaminant*. de Mora (ed). Cambridge University Press. Cambridge. pp. 212-236.
- Goldberg, E.D. 1992. Marine metal pollutants: a small set. *Marine Pollution Bulletin*. **25**:45-7.
- Gollasch, S. 1999. Personal Communication, The Institute for Marine Studies in Kiel Germany. E-Mail: sgollasch@aol.com
- Hall, L.W. 1986. Monitoring organotin concentrations in Maryland waters of Chesapeake Bay. In: *Interagency Workshop on Aquatic Monitoring and Analysis for Organotin*. Published by NOAA/NMPPO. Rockville, MD. pp. 27-28.
- Hall, L.W., M.J. Lenkevich, W.S. Hall, A.E. Pinkney and S.J. Bushong. 1986. Monitoring organotin concentrations in Maryland waters of Chesapeake Bay. *Proceedings Oceans '86 Organotin Symposium*. Marine Technology Society. Washington, D.C. Vol. 4:1275-1279.
- Hall, L.W., Jr., M.J. Lenkevich, W.S. Hall, A.E. Pinkney and S.J. Bushong. 1987. Evaluation of butyltin compounds in Maryland waters of Chesapeake Bay. *Marine Pollution Bulletin*. **18**:78-83.
- Hall, L.W. Jr., 1988 Tributyltin environmental studies in Chesapeake Bay. *Marine Pollution Bulletin*. **19**(9):431-438.
- Hartl, Mark G.J. 1999. Personal Communication. University of South Hampton. School of Ocean and Earth Science. Tel. (44) (1703-596-6271. E-Mail: hartl@soton.ac.uk.
- Huggett, R.J. 1986. Monitoring tributyltin in Southern Chesapeake Bay. In: *The Proceedings of the Interagency Workshop on Aquatic Monitoring and Analysis for Organotin*. Sponsored by NOAA/NMPPO. Rockville, MD. pp. 29-30.
- Huggett, R.J. 1987. Statement for Senate Hearing. The effects of the chemical tributyltin (TBT) on the marine environment. Hearing Record. Senate Subcommittee on Environmental Protection of the Committee on Environment and Public Works. April 29. S. HGR 100-89. U.S. Gov. Print. Office. 73-832. Washington, DC. pp. 23-28 (oral) and pp. 68-74 (written).
- Huggett, R.J., M.A. Unger and D.J. Westbrook. 1986. Organotin concentrations in southern Chesapeake Bay. *Proceedings Oceans '86 Organotin Symposium*. Marine Technology Society. Washington, D.C. Vol. 4:1262-1265.
- Huggett, R.J., M.A. Unger, P.F. Seligman and A.O. Valkirs. 1992. The marine biocide tributyltin. *Environmental Science and Technology*. **26**(2):232-237.
- Huggett, R.J., D.A. Evans, W.G. MacIntyre, M.A. Unger, P.F. Seligman and L.W. Hall. 1996. Tributyltin concentration in waters of the Chesapeake Bay. In: *Organotin: Environmental Fate and Effects*. Champ and Seligman (eds). Chapman & Hall. London. pp.485-502.
- Kram, M.L., P.M. Stang and P.F. Seligman. 1989. Adsorption and desorption of tributyltin in sediments of San Diego Bay and Pearl Harbor. *Appl. Organomet. Chem.* **3**, 523-536.
- Keeley, K. L. 1999. Personal Communication. U.S. EPA Region 10 1200 Sixth Avenue. Seattle Washington. 98101. E-Mail: keeley.karen@epa.gov
- Langston, W.J. and G.R. Burt. 1991. Bioavailability and effects of sediment-bound TBT in deposit-feeding clams. *Scrobicularia plana*. *Marine Environmental Research*. **32**:61-77.
- Laughlin, R.B. 1996. Bioaccumulation of TBT by aquatic organisms. In *Organotin: Environmental Fate and Effects* (Champ and Seligman, Eds). Chapman and Hall, Oxford. Chapter 16. pp. 331-355.
- Lewis, A.G. and W.R. Cave. 1982. The biological importance of copper in oceans and estuaries. *Oceanography and Marine Biology Annual Reviews*. **20**:471-695.
- MacLellan, D., M.S. Brancato, D. DeForest and J. Volosin. 1999. An evaluation of risks to U.S. Pacific Coast otters exposed to Tributyltin. *Proceedings Oceans '99 International Symposium on the Treatment of Regulated Discharges from Shipyards and Drydocks*. Marine Technology Society. Washington, D.C. This Volume.
- McCarty, L.S., 1991. Toxicant Body Residues: Implications for Aquatic Bioassays With Some Organic Chemicals. In: *Aquatic Toxicology and Risk Assessment* (Mayes and Barron, Eds).

- American Society for Testing and Materials. Philadelphia. pp. 183-192.
- McCarty, L.S., and D. Mackay. 1993. Enhancing Ecotoxicological Modeling and Assessment. *Environmental Science and Technology*. **27**(9):1719-1728.
- Meador, J.P. 1997. Comparative toxicokinetics of tributyltin in five marine species and its utility in predicting bioaccumulation and acute toxicity. *Aquatic Toxicology*. **37**:307-326.
- Meador, J.P. 2000. Predicting the fate and effects of tributyltin in marine systems. *Reviews of Environmental Contamination and Toxicology*.
- Meador, J. P. and C.A. Rice. (In Press). Impaired growth in the polychaete *Armandia brevis* exposed to tributyltin in sediment. *Marine Environmental Research*.
- Mikami, M. 1999. Personal Communication. Kansai Paint (America), Inc. Two Executive Drive, Suite 785. Fort Lee, NJ 02024. E-Mail: mmikami@kpacamerica.com
- Minchin, D., C.B. Duggan and W. King. 1987. Possible effects of organotins on scallop recruitment. *Marine Pollution Bulletin*. **18**(11)604-608.
- Minchin, D. 1995 Recovery of a population of the flame shell, *Lima hians*, in an Irish bay previously contaminated with TBT. *Environmental Pollution*. **90**: 259-262.
- Minchin, D., J. Oehlmann, C.B. Duggan, E. Stroben and M. Keatinge. 1995. Marine TBT antifouling contamination in Ireland, following legislation in 1987. *Marine Pollution Bulletin*, **30**:633-639.
- Minchin, D. and J. Sheehan. 1999. The significance of ballast water in the introduction of exotic marine organisms to Cork Harbor, Ireland. ICES Coop. Res. Rep. No. 224. pp 12-24
- Minchin, D. 1999. Personal Communication. Fisheries Research Centre, Department of the Marine, Abbotstown, Dublin 15, Ireland. dminchin@frc.ie
- Nicholson, C.J., S.M. Evans, N. Palmer and R. Smith. 1998. The value of imposex in the dogwhelk *Nucella lapillus* and the common whelk *Buccinum undatum* as indicators of TBT contamination. *Invertebrate Reproduction and Development*. **34**:289-300.
- ORTEPA (Organotin Environmental Programme Association). 1996. The present status of TBT-copolymer antifouling paints. Proceedings of an International One Day Symposium on Antifouling Paints for Ocean Going Vessels. 21 February 1996. The Hague. The Netherlands.
- ORTEPA (Organotin Environmental Programme Association). 1997. Harmful Effects of the Use of Antifouling Paints for Ships. Stewen (ed). Organotin Environmental Programme Association (ORTEP Association). Witco GmbH. Germany. 187p.
- ORTEPA (Organotin Environmental Programme Association). 1998. Further updates on the toxicology of tributyltin, including assessments of risks to humans, wildlife and aquatic life. Stewen (ed). Organotin Environmental Programme Association (ORTEP Association). Witco GmbH. Germany. 181p.
- Reise, K., S. Gollasch and W.J. Wolff. 1999. Introduced marine species of the North Sea coasts. *Helgolander Meeresunters*. **52**:219-234.
- Rilov, G., Y. Benayahu, S.M. Evans and A. Gasith. 1999. Unregulated use of TBT-based antifouling paints and TBT pollution in Israel. *Marine Ecology Progress Series*. (In press).
- Ritsema, R. T. de Samle, L. Loens, A.S. de Jong and O.F.X. Donard. 1998. Determination of butyltins in harbour sediment and water by aqueous phase ethylation GC-ICF-MS and hydride generation GC-AAS. *Environmental Pollution*. **99**:271-277.
- Rouhi, A.M. 1998. The Squeeze on Tributyltins. C&E News. American Chemical Society, Washington, D.C. April 27. pp. 41-42.
- Russell, D., M.S. Brancato and H.J. Bennett. 1996. Comparison of trends in tributyltin concentrations among three monitoring programs in the United States. *Journal of Marine Science and Technology*. **1**:230-238.
- Salazar, M.H. 1986. Environmental significance and interpretation of organotin bioassays. In: Proceedings, Oceans 1986 Conference, 23-25 September 1986, Washington, D. C., Organotin Symposium, Vol. 4, pp. 1240-1244.
- Salazar, M.H. 1989. Mortality, growth and bioaccumulation in mussels exposed to TBT: Differences between the laboratory and the field. Proceedings, Oceans 1989 International Organotin Symposium. Marine Technology Society. Washington, D.C. Vol. 2. pp. 530-536.
- Salazar, M.H. 1999. Personal Communication. Applied Biomonitoring. 11648 72nd Place, NE,

- Kirkland, WA 98034. Tel. (425) 823-3905, Fax (425) 814-4998, msalazar@cnw.com
- Salazar, M.H. and S.M. Salazar. 1987. TBT effects on juvenile bivalve growth. SETAC Eighth Annual Meeting, 9-12 November 1987, Pensacola, Florida. Abstract Only (#330).
- Salazar, M.H. and M.A. Champ. 1988. Tributyltin and water quality: a question of environmental significance. Published in the Proceedings of the National Organotin. Marine Technology Society, Washington, D.C., and the IEEE Service Center. 445 Hoes Lane. Piscataway, N.J. 08854. U.S.A. Vol. 4. pp 1497-1506.
- Salazar M.H. and S.M. Salazar. 1991. Assessing site-specific effects of TBT contamination with mussel growth rates. *Marine Environmental Research*. **32**(1-4):131-150.
- Salazar, M.H. and S.M. Salazar. 1996. Mussels as bioindicators: effects of TBT on survival, bioaccumulation, and growth under natural conditions. *In: Organotin: Environmental Fate and Effects*. Champ and Seligman (Eds). Chapman & Hall. London. pp. 305-330.
- Salazar M.H. and S.M. Salazar. 1998. Using caged bivalves as part of an exposure-dose-response triad to support and integrated risk assessment strategy. *In: Ecological Risk Assessment: A Meeting of Policy and Science*. De Peyster and Day (Eds). SETAC Press. pp 167-192.
- Salazar, M.H. and S.M. Salazar. 1999a. Characterizing exposure and effects of TBT in bivalves using tissue chemistry and sublethal endpoints. Proceedings, Puget Sound Sediment Management Annual Review Meeting, Lacey, WA. April 1999, 12 pp.
http://www.nws.usace.army.mil/dmmo/TBT_EXP.PDF
- Salazar, M.H. and S.M. Salazar. 1999b. Using the exposure-dose-response triad in laboratory and field bioassays: Lessons learned from caged bivalves and TBT. 20th Annual SETAC Meeting, Philadelphia, Pennsylvania. 14-18 November 1999 (platform presentation).
- Salazar, M.H. and S.M. Salazar. (In preparation). Lessons learned from caged bivalves and TBT.
- Salazar, M.H. 1999. Personal Communication. Applied Biomonitoring. 11648 72nd Place, NE, Kirkland, WA 98034. Tel. (425) 823-3905, Fax (425) 814-4998, msalazar@cnw.com
- Seligman, P. F., J. G. Grovhoug, A. O. Valkirs, P. M. Stang, R. Fransham, M. O. Stallard, B. Davidson and R. F. Lee. 1989. Distribution and fate of tributyltin in the United States marine environment. *Appl. Organomet. Chem.* **3**, 31-47.
- Seligman, P.F., J.G. Grovhoug, R.L. Fransham, B. Davidson, A.O. Valkirs. 1990. U.S. Navy Statutory Monitoring of Tributyltin in Selected U.S. Harbors. Annual Report: 1989. Naval Ocean Systems Center Technical Report No. 1346. Naval Ocean Systems Center, San Diego, CA. 32p.
- Seligman, P.F., C.M. Adema, J.Grovhoug, R.L. Fransham, A.O Valkirs, M.O. Stallard and P.M. Stang. 1996. Environmental loading of tributyltin from drydocks and ship hulls. *In: Organotin: Environmental Fate and Effects*. Champ and Seligman (Eds). Chapman & Hall. London. pp.405-428.
- Seligman, P.F. and A. Zirino (Eds). 1998. Chemistry, Toxicity, and Bioavailability of Copper and Its Relationship to Regulation in the marine Environment. Office of Naval Research Workshop Report, Technical Document No. 3044. U.S. Navy. SPAWAR Systems Center, San Diego. 51p.
- Svavarsson, J. and H. Skarphedinsdottir. 1995. Imposex in the dogwhelk *Nucella lapillus* (L.) in Icelandic waters. *Sarsia*. **80**, 35-40.
- Tester, M. and D.V. Ellis. 1995. TBT controls and the recovery of whelks from imposex. *Marine Pollution Bulletin*. **30**:90-91.
- Tester, M., D.V. Ellis and J.A.J. Thompson. 1996. Neogastropod imposex for monitoring recovery from marine TBT contamination. *Environmental Toxicology and Chemistry*. **15**:560-567.
- Toll, J., M.S. Brancato and D. DeForest. 1999. Regulating biocidal antifoulants: creating a level playing field. Proceedings Oceans '99 International Symposium on the Treatment of Regulated Discharges from Shipyards and Drydocks. Marine Technology Society, Washington, D.C. This Volume.
- U.S. EPA (Environmental Protection Agency), Chesapeake Bay Program. 1987 Survey of tributyltin and dibutyltin concentrations at selected harbors in Chesapeake Bay - Final Report. CBP/TRS 14/87. Annapolis, MD. 58p. + Appendix 40p.
- U.S. EPA (Environmental Protection Agency) 1991. Report to Congress on Environmental Monitoring of Organotin. OPTS (Office of Pesticides and Toxic

- Substances). Office of Pesticide Programs. Washington, D.C. 23p.
- U.S. EPA (Environmental Protection Agency). 1996a. Recommendations for screening values for tributyltin in sediments at Superfund sites in Puget Sound, Washington. Technical Report. EPA 910-R-96-014. Region 10. Seattle, Washington.
- U.S. EPA (Environmental Protection Agency) 1996b. Report to Congress on Alternatives to Organotin Antifoulants and Alternative Antifoulant Research. Draft: December, 1996. EPA Office of Pesticide Programs. Special Review and Registration Division (7508W) 401 M Street, SW. Washington, DC 20460. 35p.
- U.S. EPA. 1999. Technical Memorandum: Topics related to the tributyltin study at the Harbor Island Superfund Site Waster Sediment Operable Unit. U.S. EPA Region 10. Seattle, WA. 15p.
- U.S. Navy. 1997. Navy Program to Monitor Ecological Effects of Organotin. A Report to Congress. Prepared by P.S. Seligman of Marine Environmental Support Office and Jill Bloom of the EPA Office of Prevention, Pesticides and Toxic Substances and EPA Office of Water. Sept. 1, 1997. (Commonly Referred to as the Navy Risk Assessment for TBT). 76p.
- Valkirs, A.O., B. Davidson, L.L. Kear, R.L. Fransham, J.G. Grovhoug, and P.F. Seligman. 1991. Long-term monitoring of Tributyltin in San Diego Bay California. *Marine Environmental Research*. **32**:151-167.
- Wade, T.E., B. Garcia-Romero and J.M. Brooks. 1991. Oysters as biomonitors of butyltins in the Gulf of Mexico. *Marine Environmental Research*. **32**:233-241.
- Waite, M.E., M.J. Waldock, J.E. Thain, D.J. Smith and S. M. Milton. 1991. Reductions in TBT concentrations in UK estuaries following legislation in 1986 and 1987. *Marine Environmental Research*. **32**:89-111.
- Waite, M.E., J.E. Thain, M.J. Waldock, J.J. Cleary, A.R.D. Stebbing and R. Abel. 1996. Changes in concentrations of organotins in water and sediment in England and Wales following legislation. Chapter 27. *In: Organotin: Environmental Fate and Effects*. Champ and Seligman (eds). Chapman & Hall. London. pp. 553-580.
- Waldock, M.J. Thain, J.E. and M.E. Waite. 1987. The distribution and potential toxic effects of TBT in UK estuaries during 1986. *Applied Organometallic Chemistry*. **1**:287-301.
- Waldock, M.J., M.E. Waite and J.E. Thain. 1988. Inputs of TBT to the marine environment from shipping activity in the U.K. *Environmental Technology Letters*. **9**:999-1010.
- Weston. 1994. Harbor Island remedial investigation report. Prepared for U.S. Environmental Protection Agency. Region 10. Seattle, Washington. Roy F. Weston, Inc. Seattle, WA.
- White, H.H. and M.A. Champ. 1983. The great bioassay hoax and alternatives. *In: Hazardous and Industrial solid Waste Testing*. Amer. Soc. of Testing and Materials. ASTM-STP-805. pp.299-312.
- Widdows, J., K.A. Burns, N.R. Menon, D.S. Page and S. Soria. 1990. Measurement of physiological energetics (scope for growth) and chemical contaminants in mussels (*Arca zebra*) transplanted along a pollution gradient in Bermuda. *Journal Experimental Marine Biology and Ecology*. **138**(1,2):99-117.

The Effects of Regulating the Use of TBT-Based Antifouling Paints on TBT Contamination

S.M. Evans and R. Smith

Dove Marine Laboratory
Department of Marine Sciences and Coastal Management
Newcastle University
Cullercoats
Tyne and Wear, NE30 4PZ
UK

e-mail: s.m.evans@ncl.ac.uk

ABSTRACT

There was severe TBT pollution in coastal waters in the mid-1980s, particularly in areas of high shipping and mariculture activity. Organotin concentrations were high in water samples, sediments and tissues of marine molluscs. Responses, such as imposex in whelks and shell growth abnormalities in oysters, which can be caused by TBT, were also well-developed. They were associated with reproductive failure, and even local extinction of species, in the most severe cases. However, several governments have regulated the use of TBT-based antifouling paints, prohibiting their application to vessels <25m in length. These regulations have been highly successful in reducing TBT pollution. Environmental concentrations of TBT have decreased, and there has been substantial recovery of populations of whelks and oysters. Serious TBT contamination is now restricted largely to ports and harbours, especially those with dry-docking facilities.

I. INTRODUCTION

Tributyltin (TBT) leaches into the marine environment from the antifouling paints which are used on the hulls of boats and mariculture cages. It is potentially highly toxic at low concentrations. This is reflected in low lethal dose (LD) concentrations to TBT in sea water, especially in the case of larvae of invertebrates. For example, the 15day LC50 for larvae of the common mussel *Mytilus edulis* is 0.1 ug/l. However, sub-lethal impacts occur at even lower concentrations. No Observed Effect Concentrations (NOEC) for the growth and reproduction of plankton are 0.4 ng/l, and for shell calcification in oysters and normal development of the genital system in female dogwhelks, 2 ng/l.

TBT has a short residence time of days only in the water column but it becomes adsorbed on to particles and aggregates in sediments, where its half-life may be a matter of years.

There was widespread use of TBT-based antifoulants by the 1980s, and the worst contaminated areas were semi-enclosed bodies of water, which have poor flushing characteristics and in which there was intensive shipping (or ship-related) activity or mariculture. The concentrations recorded in 'hot-spots', such as harbours, marinas, dry docks, estuaries, sealochs and bays, were often well above NOECs. For example, concentrations in the water column were mostly >100 ng/l but occasionally exceeded 300 ng/l (Batley 1996).

Not surprisingly, TBT pollution had impacts on marine biota. The best documented example is from Arcachon Bay (west France), which is a centre for both yachting and oyster culture. TBT leaching from the antifouling paints used on yachts was held responsible for abnormal shell growth and reproductive failure of oysters. Production of oysters fell to about 33-50 % of the normal harvest (Table 1). A similar collapse of oyster farming was reported in estuaries in southern England, and TBT was the probable cause of declines in populations of other bivalve molluscs.

TBT was also linked to declines in populations of dogwhelks *Nucella lapillus* in areas of high boating activity in southwest England (Bryan *et al.* 1986). Female *N. lapillus* developed the condition known as imposex in which male characteristics, including a penis and vas deferens, become superimposed on the female's own genitalia. It can cause sterility because the vas deferens becomes convoluted and forms a nodule which blocks the genital pore. As a consequence, the species became locally extinct in Plymouth Sound and in the estuaries of the rivers Dart and Fal.

Subsequently, advanced symptoms of imposex were recorded in *N. lapillus* at other North Atlantic sites, and in other whelk species in Canada, New Zealand, Australia, Japan, Indonesia, Malaysia, Hong Kong, Singapore, the Malacca Strait, Thailand, Israel, Malta, the Mediterranean Sea, Ghana and the Canary Islands. TBT contamination was a widespread problem (Ellis and Pattisina 1980).

Table 1. Production of oysters in Arcachon Bay, France.

Period	Production (tons)
1978-79	10000
1979-80	6000
1980-81	3000
1981-82	5000
1982-83	8000
1983-84	12000
1984-85	12000

II. MANAGING TBT POLLUTION: THE EFFECTIVENESS OF REGULATIONS.

Basically two approaches have been used to reduce TBT pollution. One of these was to ban the use of TBT-based antifoulants on small pleasure craft which were believed to be the main source of contamination in coastal waters. The other approach was to regulate the paints themselves. This was done by, for example, encouraging the use of new copolymer self-polishing paints, which have relatively slow TBT release rates, and discouraging the use of the original free association paints, from which TBT leaches more rapidly. France was the first to introduce regulations. It did so in 1982, very much in response to the oyster farming problem in Arcachon Bay. The use of TBT-based antifoulants was prohibited on vessels <25m in length. Similar regulations followed in the UK, USA, Canada, New Zealand, Australia, South Africa, Hong Kong and most European countries.

There is substantial evidence that these regulations have been effective in reducing TBT contamination and the adverse effects of pollution. Reductions are due primarily to lower inputs from small boats, and declining levels of pollution have therefore been most marked in estuaries and areas where there are marinas. This has almost certainly been the cause of declining levels in water samples, sediments and the tissues of molluscs. They have been reported in studies worldwide (Table 2).

Table 2. Examples of studies in which reductions in TBT contamination have been described, based on chemical measures.

Location	Reference
UK	Dixon 1989 Cleary 1991 Bryan & Gibbs 1996
Gulf of Mexico	Wade <i>et al.</i> 1991
Australia	Batley <i>et al.</i> 1992
USA	Wuertz <i>et al.</i> 1991
France	Alzieu 1996
Japan, Europe and USA	CEFIC 1994

Concomitantly, there have been recoveries of many of the populations of molluscs which were severely impacted in the 1980s. These have sometimes been dramatic. Oyster farming in France recovered almost immediately after the introduction of regulations in 1982 (Table 1), and oyster farming in England and Australia also improved rapidly following the regulations in these countries. In addition, there has been widespread recovery of populations of other bivalves and gastropods (Table 3).

Table 3. Examples of studies in which recoveries of populations of molluscs have been described, since the introduction of regulations limiting the use of TBT-based antifoulants.

Species	Location	Reference
Dogwhelks	Clyde Sea North Sea	Evans <i>et al.</i> 1996
Dogwhelks	Canada	Tester <i>et al.</i> 1996
Dogwhelks	New Zealand	Smith 1996
Mud snails	USA	Curtis 1998
Oysters	France	Alzieu 1996
Oysters	Australia	Batley <i>et al.</i> 1992
Scallops	Ireland	Minchin <i>et al.</i> 1987
Flame shells	Ireland	Minchin 1995

A recent (1998) survey of imposex in dogwhelks *N. lapillus* along North Sea coastlines illustrates the extent to which recovery has occurred. It was reported that in 1991 there was either total or partial sterility in two thirds of the populations surveyed from Norway, Denmark, the Netherlands, France and the UK (Harding *et al.* 1992). Widespread extinctions might have been predicted. However, the species was present on all of the shores which were revisited in 1998, and it was common or abundant on most of them. Symptoms of imposex had declined, and they were reproducing successfully (Table 4).

Table 4. Measures of imposex (RPSI and VDSI) in North Sea dogwhelks sampled in 1991 and 1998.

	Survey	
	1991	1998
	Norway and Denmark	
Number sites	21	12
Mean RPSI	38	19
Mean VDSI	4.5	3.6
	France	
Number sites	16	18
Mean RPSI	18	6
Mean VDSI	3.9	3.3
	United Kingdom	
Number sites	20	15
Mean RPSI	16	8
Mean VDSI	3.7	3.3

Commercial harbours, especially those with shipyards and dry docks, remain contaminated by TBT. This is because ocean-going vessels continue to use TBT-based antifoulants, and consequently it continues to accumulate in harbour sediments. However, there is evidence of recovery of populations of dogwhelks *N. lapillus* in Sullom Voe (Scotland) where the only source of TBT is from tankers which visit the oil terminal there. It can probably be attributed to the widespread use of copolymer coatings, replacing free association paints.

III. THE FUTURE OF TBT-BASED ANTIFOULANTS: MANAGEMENT OR BAN ?

It is unfortunate that a full understanding of the effectiveness of regulations in managing environmental levels of TBT is becoming apparent only at a time when the International Maritime Organisation (IMO) is considering the introduction of a total ban on TBT-based antifoulants. It is currently considering draft regulations whereby the application of

TBT-based coatings will be banned from 2003, and TBT paints (from previous applications) will not be allowed on hulls from 2008.

TBT-based paints have achieved a notoriety which is not justified by the scientific evidence. Furthermore, there is no doubt that additional regulations could reduce ambient levels of TBT still further. There could, for example, be stricter controls for paint application and removal procedures, dockyard waste disposal and the use and availability of paints. Research is also needed to create new technologies for the treatment of TBT-contaminated waste water, more efficient and less toxic paints and offshore ports where the dilution of open waters will reduce pollution.

The ultimate objective must be to veto the use of all toxins in the marine environment and the use of TBT, or other biocides, should eventually be outlawed. However, there are increasing concerns that the proposed ban on TBT-based antifoulants is premature. A ban will mean the immediate introduction of alternatives. However, the long-term biocidal properties of alternatives are largely untested, and it is difficult to predict either the economic or environmental consequences of using them. Poor antifouling performance will certainly be costly for the shipping industry because it will result in higher fuel consumption and the need to slip and repaint vessels more often. There may also be environmental consequences. Increased fuel consumption will lead to an increase in emissions of 'greenhouse' and 'acid rain' gases. In addition, the increased spread of those 'invasive' (non-native) species, which are carried on the hulls of fouled ships, is likely to become a major problem. They already cause enormous ecological and economic damage, and could become the cause of an environmental disaster. There is a need, furthermore, to demonstrate the alternatives are actually more 'environmentally friendly' than TBT. It is claimed that one alternative, the herbicide booster Irgarol 1051, which is already in use, is at environmental levels which are sufficient to damage phytoplankton communities. Several alternatives contain high levels of copper, and increased copper content of oysters in Arcachon Bay has been linked with the increased use of such paints, following the ban of TBT-based paints on small boats.

IV. REFERENCES

- Alzieu, C. (1996) Biological effects of tributyltin on marine organisms. In *Tributyltin: Case Study of an Environmental Contaminant*, ed. S.J. de Mora. Cambridge University Press, pp. 167-211.
- Batley, G. (1996) The distribution and fate of tributyltin in the marine environment. In *Tributyltin: Case Study of an Environmental Contaminant*, ed. S.J. de Mora. Cambridge University Press, pp. 139-166.
- Batley, G.E., Scammell, M.S. and Vrockbank, C.I. (1992) The impact of the banning of tributyltin-based antifouling paints on the Sydney rock oyster *Saccostrea commercialis*. *Science of the Total Environment* **122**, 301-314.
- Bryan, G.W., Gibbs, P.E., Burt, G.R. and Hummerstone, L.G. (1986) The decline of the gastropod *Nucella lapillus* around southwest England: evidence for the effects of tributyltin from anti-fouling paints. *Journal of the Marine Biological Association of the United Kingdom* **66**, 611-640.
- CEFIC (1994) Use of triorganotin compounds in anti-fouling paints. results of TBT monitoring studies. Paper submitted to International Maritime Organisation Marine Environment Protection Committee 35th Session: Agenda 17.
- Cleary, J.J. (1991) Organotin in the marine surface microlayer and subsurface waters off southwest England: relation to toxicity thresholds and the UK environmental quality standard. *Marine Environmental Research* **32**, 65-73.
- Dixon, T. (1989) Early response to TBT ban. *Marine Pollution Bulletin* **20**, 2.
- Ellis, D.V. and Pattisina, L.A. (1990) Widespread neogastropod imposex: a biological indicator of global TBT contamination. *Marine Pollution Bulletin* **21**, 248-253.
- Evans, S.M., Evans, P.M. and Leksono, T. (1996) Widespread recovery of dogwhelks, *Nucella lapillus* (L.) from tributyltin contamination in the North Sea and Clyde Sea. *Marine Pollution Bulletin* **32**, 263-269.
- Harding, M.J.C., Bailey, S.K. and Davies, I.M. (1992) TBT imposex survey of the North Sea. UK Department of the Environment. Contract PECD 7/8214.
- Minchin, D. (1995) Recovery of a population of the flame shell *Lima hians* in an Irish bay previously contaminated with TBT. *Environmental Pollution* **90**, 259-262.
- Minchin, D., Oehlmann, J., Duggan, C.B., Stroben, E. and Kaetinge, M. (1995) Marine TBT antifouling contamination in Ireland, following legislation in 1987. *Marine Pollution Bulletin*, **30**, 633-639.
- Smith, P.J. (1996) Selective decline in imposex levels in the dogwhelk *Lepsiella scobina* following a ban on the use of TBT antifoulants in New Zealand. *Marine Pollution Bulletin* **32**, 362-365.
- Tester, M., Ellis, D.V. and Thompson, J.A.J. (1996) Neogastropod imposex for monitoring recovery from marine TBT contamination. *Environmental Toxicology and Chemistry* **15**, 560-567.
- Wade, T.L., Garcia-Romero, B. and Brohns, J.M. (1991) Oysters as biomonitors of butyltins in the Gulf of Mexico. *Marine Environmental Research* **32**, 233-341.
- Wuertz, S., Miller, C.E., Doolittle, M.M., Brennan, J.F. and Cooney, J.J. (1991) Butyltins in estuarine sediments two years after tributyltin was restricted. *Chemosphere* **22**, 1113-1120.

The Environment: Our Joint Responsibility

Stewart M. Evans

**Dove Marine Laboratory, Department of Marine Sciences and Coastal Management,
University of Newcastle Upon Tyne, Cullercoats, Tyne & Wear, NE30 4PZ, UK
Tel. (+44 (191) 252-4850, Fax (+44 (191) 252-1054,
E-Mail: M.Evans@newcastle.ac.uk**

ABSTRACT

It is argued that the environment belongs to all of us and that local communities should therefore be involved in environmental planning processes. It will require increased understanding and awareness of scientific issues in members of the public, and the development of mechanisms by which they can contribute effectively to them. Environmental education in the formal system has been disappointingly ineffective in promoting a scientifically-literate society, and it is suggested that new initiatives, such as programmes of life-long learning and the involvement of community groups in science, are needed to achieve this goal.

Community groups have traditionally managed the local environment, and there is no reason why they and other interested parties, including scientists, industrialists, members of ENGOs and politicians, should not collaborate in its management in the modern world. It will be necessary, however, to accept that 'practical solutions to human needs may require compromise between conflicting priorities'. Global issues will require a different approach but representatives from all groups in society should still be involved. One possibility is to establish advisory panels, which would address specific issues.

INTRODUCTION

The World Conservation Strategy (1980) points out that the behaviour of society as a whole must be transformed in order to develop a new conservation ethic in which humankind is prepared to live in harmony with the natural world. It recognises that lack of awareness and understanding of environmental issues in decision-makers and the general public impede this. It is argued that ecosystems are being destroyed because people do not realise that it is in their best interests to preserve them.

The concept of 'ownership' of the environment is also poorly developed in modern society. Environmental planning is seen by most of us as a distant responsibility, often involving acrimonious confrontation, between scientists, industrialists, planners, statutory bodies, 'green' environmentalists and politicians. In fact, the environment belongs, not to particular sections of society, but to all of us. It follows that a new ethic should embrace the concept that we have a joint responsibility for its future. We should all therefore have the opportunity to contribute to environmental planning processes.

However, this goal can be achieved only if: (i) ways are found of creating a society which is more scientifically-literate; and (ii) mechanisms are developed by which lay members of the community can collaborate with those with special expertise in developing strategies for sustainable use of the environment.

Awareness and Understanding of Science

The formal education system is an obvious way in which knowledge and awareness, of science can be achieved, and there has been substantially more emphasis on some of its aspects, such as man's impact on the environment, during the past two or three decades. Many schemes have highly laudable objectives. Key Stage 4 of the National School's Curriculum in England and Wales aims to produce pupils who 'form balanced judgements about some of the major environmental issues facing society' and 'recognise that practical solutions to human needs may require compromise between competing priorities'.

Regrettably however, formal programmes appear to have had insignificant impact. There is little evidence of change since Holdren & Ehrlich's (1971) reference to the 'monumental failure of biological education' in influencing the opinions of politicians and industrialists on environmental issues. Evidence that the British adult population has modest knowledge only of simple biological topics (Lucas, 1987), criticisms of school curricula for failing to address 'real' problems (Evans, 1988) and calls for further developments in environmental education (Lakin & Burch, 1996) reinforce the view that there is still much to be done.

Industrial and scientific progress is, in any case, too rapid for the formal education system to be the sole means by which society can keep abreast of new developments. It could be argued that it is the responsibility of industrialists and scientists themselves to keep the public and decision-makers up to date with their findings. Unfortunately, this does not happen. Industrialists have difficulties in getting their messages across because the public perception of industry is of an exploiter (sometimes a ruthless one) of the environment.

However, times are changing rapidly and there is increasing evidence of an enlightened approach,

in which industry, government and the community engage in open debate within a climate of mutual trust (Pearce, 1991). Scientists are probably viewed less cynically by the public than industrialists but they are notoriously bad communicators and are often portrayed unsympathetically by the media (Gray, 1999).

A compounding problem is that science has difficulty in reacting quickly to new issues because the publication of research is a slow process, due to dependence on the peer review system to maintain quality. Furthermore, since the journals in which it does eventually appear are unlikely to be read by the public, it falls largely on specialist publications, such as *New Scientist* and *Scientific American*, to present accounts of new developments and balanced views of current issues.

With the paucity of scientific information getting through to the public, the Environmental Non-Governmental Organizations (ENGOS), have enormous power to influence public opinion on major issues. In some respects they use it responsibly. In particular, ENGOS provide an excellent service in drawing the public's attention to matters of concern.

For example, World Wide Fund for Nature (WWF) has been highly successful in emphasising pollution problems in specific geographical areas, such as Antarctica (Anon., 1981), the Arctic (Anon., 1998) and the Baltic Sea (Ambrose, 1995), in identifying habitats which are endangered, such as Spanish wetlands (Anon., 1999), and in recognising threats to particular groups of organisms, such as sharks (Ambrose, 1998).

Similarly, campaigns by the Marine Conservation Society and the Keep Tidy Britain Group have highlighted problems of plastic litter pollution in the marine environment and water quality on leisure beaches in Britain (Marine Conservation Society, 1991, Anon., 1995). Greenpeace has also

raised awareness of a range of issues, such as whaling, shipments of nuclear waste and problems associated with dismantling oil rigs, often through a more confrontational approach.

NGOs could also play major roles in disseminating scientific information and to some extent they do so through, for example, the publication of books, such as the Marine Conservation Society's *Good Beach Guide* (1991) and its marine field guide (Hawkins and Jones, 1992), and Greenpeace's publications on the Mediterranean Sea (Pastor, 1991) and Baltic Sea (Leithe-Eriksen, 1992). However, NGOs often become involved in campaigns and, in these cases, the dissemination of information is less satisfactory. NGOs, not unreasonably in many ways, use selected data to support their arguments and frequently over-simplify issues.

For instance, the Greenpeace 1996 campaign against Danish fishermen who were trawling for sandeels was based on the simple message: industrial fishing is harmful to the environment and unnecessary, and should be banned. Whether this conclusion is right or wrong, the regulators had to consider the problem from other perspectives. Some influential scientific opinion did not agree with Greenpeace that the fishery was having such a severe impact on the environment, and it also became evident that natural climatic factors may have been responsible, at least in part, for declines in populations of sandeels.

There were social, economic and political considerations because, not only was the fishery of economic importance to Denmark, but Danish access to sandeel stocks had been permitted as a trade-off for the cod and haddock quotas given to other EU member states (Gray *et al.*, in press).

NGO campaigns against tributyltin (TBT) have been conducted in a similar way. TBT is the active biocide in the antifouling paints, which are applied to boat hulls. It is highly toxic, and therefore an

extremely effective antifoulant, but it has caused environmental damage by leaching from paints into the water column (de Mora, 1996). WWF's campaign has been to call for the earliest possible ban on the use of TBT-based antifoulants.

Their case is presented in two brochures, which are part of the *Living Seas* campaign: *Organotin Paints Commercially Used on the Hulls of Ships to Prevent Fouling by Marine Plants and animals are Toxic* and *The Accumulation and Impact of Organotins on Marine Mammals, Seabirds and Fish for Human Consumption* (WWF, 1999). Again, the complexities of the issue are ignored. There is, for instance, overwhelming evidence that regulations prohibiting the use of TBT-based coatings on small vessels and developments in paint technology have minimised the problem so that serious TBT contamination is now limited to commercial harbours and dry docks (Evans, 1999). There is also failure to acknowledge the part played by effective antifoulants in reducing emissions of greenhouse gases due to lower fuel consumption and preventing the spread of 'invasive species' across the world's oceans.

Even more importantly, WWF materials make no reference to concerns among scientists that the environmental profiles of alternative paints, which will be used once TBT has been banned, are poorly known (Stewart, 1996). They could be more environmentally damaging than TBT. Thus, while there is consensus among scientists, and even the chemical industry, that TBT-based paints must eventually be banned, there is serious concern about the timing of the ban. Like almost all economic versus environmental issues, informed choices between alternatives have to be made (Evans and Leksono, 1995).

We must search for non-toxic antifoulants (and there is a real chance that 'non-stick surfaces' based on silicon elastomer technology will be available in the future) but, until superior alternatives are available, we must either tolerate

some pollution from their use, or accept the economic and environmental costs of doing without them. Society as a whole should decide whether some environmental damage, in this case to communities on rocky shores near ports and other centres of boat use (which are already highly perturbed environments), is an acceptable price to pay for the benefits gained from the world's shipping industry and a cleaner atmosphere.

There is an obvious need for new educational initiatives, which will, not only raise standards of scientific literacy, but also encourage more critical evaluation of information. Equally, there are needs to promote increased feelings of ownership and responsibility towards the environment in lay members of the community, and therefore a willingness to contribute to environmental planning processes.

Adult (life-long) learning is one relatively unexploited opportunity, and Thomas (1993) cites an example of the way in which participants at an adult education course used newly acquired knowledge to persuade a farmer to conserve an area of ancient woodland. Schemes involving children of school age and adults (e.g. their parents) can also be profitable. It is taken for granted that the older, hopefully wiser, members of society instruct the younger ones. However, information transfer can occur in the reverse direction.

Evans *et al.* (1996) provide evidence that knowledge of recycling waste materials, which was gained by children at school, was transferred to their parents, and influenced their attitudes towards recycling. One initiative is the Marine Conservation Society's 'Adopt a Beach' Programme (MCF, 19xx).

Another initiative, which aims to forge a closer link between the local community and the environment, is operated by the Department of Marine Sciences and Coastal Management,

Newcastle University (UK) at its Dove Marine Laboratory. Members of the community take part in scientific exercises under the guidance of experts from industry or academia. Participants are expected to produce environmental action plans, which are based, at least in part, on their findings. Projects include assessments of TBT contamination of the North Sea, sustainable bait collection by anglers, marine biodiversity, the bycatch in the local *Nephrops* fishery, and programmes for monitoring shorebirds. The TBT project has shown that, contrary to common belief, dogwhelks *Nucella lapillus*, which were said to be seriously impacted by TBT in the North Sea (North Sea Quality Status Report (1993)), are abundant there.

It has generated interest through the media (e.g. Garfield, 1999, Pearce, 1999, Tinsley, 1999) and may therefore have had an impact on the current debate within the International Maritime Organization (IMO) on the need to ban (or regulate further) TBT-based antifoulants.

Joint Responsibility and Collaboration.

The confrontational approach is unlikely to produce effective long-term solutions to environmental problems. There is no doubt that, given the opportunity, all sections of society are capable of working together in partnership. ENGOs worked impressively with Government at the Earth Summit in Rio in 1992 (Rawcliffe, 1998). There, four ENGOs, Friends of the Earth, Campaign for the Protection of Rural England, Royal Society for the Protection of Birds (RSPB) and WWF, became actively involved in the UK Government's roundtable on sustainable development.

Furthermore, RSPB, WWF and the Wildlife Trust are members of its biodiversity working groups. There are also many examples in which these, and other ENGOs, have worked with local government in producing local biodiversity action plans.

There have also been impressive partnerships between ENGOs and industry. WWF, together with other ENGOs and representatives from the timber and retail industries, founded the Forestry Stewardship Council in 1993 (Rawcliffe, 1998). The proposal was to eco-label timber products from those sections of the industry which were prepared to manage their forests sustainably, thereby giving them a competitive advantage. By 1996, 25% of forest products sold in Britain conformed to the eco-labelling criteria. At this time, WWF also founded the Marine Stewardship Council in conjunction with Unilever to ensure that marketed fish were from sustainable fisheries.

Even more recently, WWF has been working with paint and chemical manufacturers in making comparative tests of antifouling paints. Such tests must by their nature take time because TBT-based coatings can provide effective antifouling cover for five or more years. Nevertheless, the discovery of alternative tin-free paint systems, which are shown on full environmental and economic analyses, to be less harmful to the environment than TBT-based paints, is one of the bases on which regulatory decisions should be made.

Unfortunately however, collaboration has not yet replaced confrontation. The position of at least some ENGOs is ambivalent. Greenpeace worked successfully with industry in producing and marketing an 'ozone-friendly' refrigerator *Greenfreeze* (Rose, 1997) but is prepared to take direct action against other sections of industry. Gray (in press) expresses doubt that, despite claims to the contrary, there has been increased collaboration between the ENGOs and industry during the past decade. So why does confrontation occur?

It is a sad reflection if, as Eyerman & Jamison (1998) have suggested, direct actions by ENGOs are necessary to maintain the membership bases. Members of local communities too can play their parts in environmental planning. Indeed, their

involvement in them is not a new concept at all. The traditional management of coastal fisheries has, for example, been community-based in many parts of the world. These communities had real or perceived ownership of the area in which they fished, and controlled access to it (Ruddle, 1994).

Such systems have tended to collapse in modern times, due predominately to western influences (Johannes, 1978), but they are still practised in remote regions, such as parts of western Africa (Gordon, 1989) and the Maluku Province in Indonesia (Evans *et al.*, 1997). Ruddle (1988) has suggested that there is much to be learned from them, and that it would be of great benefit if the best of modern management practices could be blended with the best of their traditional counterparts in developing cost-effective management strategies for coastal fisheries.

The proposal is supported by evidence that community-based management can work in the modern world. There have been significant improvements in reef quality, and fish diversity and abundance, on Apo, Negros, Pamilacan and Balicasag islands in the Philippines, following the introduction of a community-based system of management (White & Savina, 1987).

The importance of the community approach to fisheries management, in the sense of involving fishermen in the decision-making processes, has also been recognised in other parts of the Philippines (Pomeroy and Pido, 1994), Denmark (Nielsen, 1994) and Japan (Lim *et al.*, 1995).

However, while it is feasible to involve communities in planning processes, which affect the local or regional environment, it is unrealistic to expect their participation in global regulatory processes. There is nevertheless the same need for informed debate, which is unhindered by misleading or unbalanced information. Equally, there is a need for representation from all sections of society.

One way of doing this would be through the establishment of panels whose members would review the available data and make recommendations to the relevant world regulatory authorities. The proposal therefore has much in common with Champ's (1999) suggestion that IMO should form a Marine Coatings Board to consider the TBT issue. It would be expected to expedite the process of creating data and information on which the development and comparative evaluation (including standardised testing) of antifoulants could be made. Champ suggests that it might be a private-public partnership between industry, government and academia but there is still a place for the well-informed non-expert to provide an unbiased input, or perhaps to chair, such a panel.

REFERENCES

- Ambrose. 1995.
 Ambrose. 1998.
 Anon 1981.
 Anon 1995.
 Anon 1998.
 Anon 1999.
 Champ, M.A. 1999. The need for the formation of an independent, international marine coatings board. *Marine Pollution Bulletin*. **38**(4):239-246.
 de Mora. 1996.
 Evans. 1988.
 Evans & Leksono. 1995.
 Evans *et al.* 1996.
 Evans *et al.* 1997.
 Evans. 1999.
 Eyerman & Jamison. 1998. Forestry Stewardship Council. 1993
 Friends of the Earth. 1999. Campaign for the Protection of Rural England, Royal Society for the Protection of Birds (RSPB)
 Garfield. 199.
 Gordon. 1989.
 Gray. 1999.
 Gray (in press)
 Gray *et al.* in press
 Hawkins & Jones. 1992.
 Holdren & Ehrlich's. 1971.
 Johannes. 1978.
 Lakin & Burch. 1996.
 Leithe-Eriksen. 1992.
 Lim *et al.* 1995.
 Lucas. 1987.
 Marine Conservation Society's 'Adopt a Beach' Programme.
 Marine Conservation Society. 1991.
 Marine Conservation Society's *Good Beach Guide*. 1991.
 Marine Stewardship Council
 North Sea Quality Status Report. 1993.
 Nielsen. 1994.
 Pastor. 1991.
 Pearce. 1991.
 Pearce. 1999.
 Pomeroy & Pido. 1994.
 Rawcliffe. 1998
 Rose. 1997.
 RSPB,
 Ruddle. 1988.
 Ruddle. 1994.
 Stewart. 1996
 Thomas. 1993.
 Tinsley. 1999.
 White & Savina. 1987.
 Wildlife Trust WWF. 19xx.
 WWF's *Living Seas* campaign: *Organotin Paints Commercially Used on the Hulls of Ships to Prevent Fouling by Marine Plants and animals are Toxic and The Accumulation and Impact of Organotins on Marine Mammals, Seabirds and Fish for Human Consumption.*

REPORT DOCUMENTATION PAGE

Form Approved
OMB No. 0704-0188

Public reporting burden for this collection of information is estimated to average 1 hour per response, including the time for reviewing instructions, searching existing data sources, gathering and maintaining the data needed, and completing and reviewing the collection of information. Send comments regarding this burden estimate or any other aspect of this collection of information, including suggestions for reducing this burden to Washington Headquarters Services, Directorate for Information Operations and Reports, 1215 Jefferson Davis Highway, Suite 1204, Arlington, VA 22202-4302, and to the Office of Management and Budget, Paperwork Reduction Project (0704-0188), Washington, DC 20503.

PLEASE DO NOT RETURN YOUR FORM TO THE ABOVE ADDRESS.

1. REPORT DATE (DD-MM-YYYY) 39 December 1999		2. REPORT TYPE Final		3. DATES COVERED 1 June to 30 Dec. 1999	
4. TITLE AND SUBTITLE "Treatment of Regulated Discharges from Shipyards and Drydocks" Proceedings from Special Sessions, Oceans '99 Conference, Seattle Washington. September 13-16, 1999.				5a. CONTRACT NUMBER	
				5b. GRANT NUMBER N00014-98-1-0811	
				5c. PROGRAM ELEMENT NUMBER	
6. AUTHOR(S) Michael A. Champ, Thomas J. Fox, and Alan J. Mearns (Volume Editors).				5d. PROJECT NUMBER	
				5e. TASK NUMBER	
				5f. WORKUNIT NUMBER	
7. PERFORMING ORGANIZATION NAME(S) AND ADDRESS(ES) ATRP Corporation, P.O. Box 2439, 7000 Vagabond Drive, Falls Church, Virginia 22042 Tel. (703) 237-0505, Fax (703) 241-1278. E-Mail: machamp@aol.com				8. PERFORMING ORGANIZATION REPORT NUMBER ATRP Corp. T.R. 99/1	
9. SPONSORING/MONITORING AGENCY NAME(S) AND ADDRESS(ES) Office of Naval Research (ONR), Ballston Centre Tower One, 800 North Quincy Street, Arlington, VA 22217-5660				10. SPONSOR/MONITOR'S ACRONYM(S) ONR Code 331	
				11. SPONSOR/MONITOR'S REPORT NUMBER(S)	
12. DISTRIBUTION/AVAILABILITY STATEMENT Approved for Public Release; Distribution is Unlimited.					
13. SUPPLEMENTARY NOTES					
14. ABSTRACT The papers in this Oceans '99 Proceedings Volume represent a global update and state-of-the-art on the treatment of regulated discharges from shipyards and drydocks. The panel discussion identified a series of major concerns or issues from the papers presented that became recommendations for further consideration by interested parties, be they governments (local, regional or national), the shipping industry, the shipyard industry, port and harbor authorities or NGOs such as environmental organizations.					
15. SUBJECT TERMS Characterization of Discharges, Discharge Permits, Regulation, Tributyltin, TBT, Cu, Waste Treatment Systems, Shipyards, Drydocks, Ship Washdown and Shipyard Waste waters, Storm Runoff, Modeling, Environmental Fate and Effects, Bioaccumulation of TBT, Risk, Contamination, Marine Mammals, Surface Waters, Bottom Sediments, Costs, Solid Wastes					
16. SECURITY CLASSIFICATION OF:			17. LIMITATION OF ABSTRACT	18. NUMBER OF PAGES	19a. NAME OF RESPONSIBLE PERSON
a. REPORT	b. ABSTRACT	c. THIS PAGE			Michael A. Champ
Unclassified	Unclassified	Unclassified	Unclassified	223	19b. TELEPHONE NUMBER (Include area code) (703) 237-0505

DEWATERING AND WATER TREATMENT OPERATIONS OF THE OTTAWA RIVER SEDIMENT REMEDIATION PROJECT

William J. Cretens¹

ABSTRACT

The Ottawa River Sediment Remediation Project, performed in Toledo, Ohio in 2010, involved hydraulic dredging to remove approximately 242,000 cubic yards of PCB contaminated sediment from the Ottawa River. The following describes landside operations on this project which involved dewatering the dredged sediment with geotextile tubes, as well as collecting and treating the water released from the sediment during the dewatering process. The methods and operating strategies utilized in landside operations proved to be very successful in accomplishing the major goals of the project.

Keywords: Geotextile tubes, sediment dewatering, water treatment, dredged material disposal, contaminated sediment

INTRODUCTION

Infrastructure Alternatives, Inc. (IAI) served as the Landside General Contractor for the Ottawa River Remediation Project. Landside operations were located at the Hoffman Road Landfill in Toledo, Ohio and took place over the course of 11 months, beginning with construction in February 2010. About 185,022 m³ (242,000 yd³) of polychlorinated bi-phenyl (PCB) contaminated dredged material was pumped to the Hoffman Road Landfill facility for processing over the course of the project. The majority of the sediment (approximately 172,789 m³ or 226,000 yd³) was dewatered with geotextile tubes placed in a newly constructed cell of the Hoffman Road Landfill and capped in place for final disposal.



Figure 1. Aerial view of the site during construction of the sediment dewatering pads; the larger non-TSCA pad is in the foreground.

The remaining sediments (about 12,233 m³ or 16,000 yd³) were believed to be in excess of 50 ppm total PCBs and were dewatered separately from the rest of the dredged material. These more highly contaminated sediments were regulated by the Toxic Substances Control Act (TSCA) and after dewatering, were hauled off-site for disposal in a TSCA permitted landfill.

TSCA regulated and non-TSCA sediments were delivered to the site by hydraulic dredges via separate High Density Polyethylene (HDPE) pipelines, were treated with a polymer emulsion and were dewatered in separate processes.

¹ President & CEO, Infrastructure Alternatives, Inc., 7888 Childsdales Ave, Rockford, Michigan 49341, USA, T: 616-866-1600, Fax: 616-866-1611, Email: bcretens@infralt.com.

Non-TSCA sediments were screened, thickened, treated with a second dose of polymer, and then dewatered in geotextile tubes. TSCA regulated sediments were not screened or thickened but went straight to geotextile tubes for dewatering.

Water released from the sediments in the dewatering process was collected and treated on site in a temporary water treatment plant (WTP), then discharged to the Ottawa River under an NPDES permit issued by Ohio Environmental Protection Agency (OEPA). The WTP utilized inclined plate clarifiers, sand filters, bag filters and Granular Activated Carbon (GAC) adsorption vessels.



Figure 2. Aerial view of landside operations during active dewatering. The non-TSCA dewatering pad can be seen at the top of the photo, with the TSCA pad below and to the right, and the WTP pad at the bottom of the photo.

CHEMICAL CONDITIONING OF THE DREDGED SEDIMENTS

Both dry and emulsion polymer options were competitively bid for this project. Emulsion polymer was ultimately selected by the General Contractor. An emulsion polymer make down system was cheaper to install for this particular project because it could be housed completely within two 12.2 m (40 ft) long shipping containers and required only the addition of one 79,494 L (21,000 gal) frac tank to the WTP pad. A dry polymer mixing system would have required construction of a building to store the dry polymer sacks and the mixing unit, since all of the WTP equipment was installed outdoors and there was no plan for a WTP building.



Figure 3. Emulsion polymer make down system.

A cationic emulsion polymer was created in batches on site and was used to condition the sediment for dewatering. The neat solution (35 – 40% concentration) was diluted to 1% solution for application by two separate polymer make down systems, each enclosed in its own shipping container. Each make down system was capable of producing 757 L/min (200 gal/min) of diluted polymer solution, providing a total capacity of 1,514 L/min (400 gal/min) when operated simultaneously.

Diluted polymer was applied to the separate non-TSCA and TSCA regulated sediment header systems with 1,136 L/min (300 gal/min) progressive cavity pumps. The output of the polymer application pumps was automated, ramping up and down based upon real-time measurement of the dredge slurry flow rate and density, to produce the desired lbs/dry ton polymer dosage rate. The target polymer dosage rate was determined by operations staff, based upon jar tests and visual observation of floc formation in the header as well as the rate, appearance and volume of water released from the geotextile tubes.

SCREENING, THICKENING AND GEOTEXTILE TUBE DEWATERING OF NON-TSCA SEDIMENTS

Following the application of polymer, sediments not regulated by TSCA (non-TSCA) were screened with a static screen to remove large debris and then with shaker screens to remove additional debris and large coarse grain material. Each shaker screen was situated at the head of a sediment thickener, which removed free water by settling action. Separated water from the top of the thickeners flowed to the WTP for treatment. Underflow from the thickeners (thickened sediment) was treated with a secondary dose of polymer, and then pumped to the non-TSCA dewatering pad for dewatering in geotextile tubes.



Figure 4. Sediment thickeners

The non-TSCA dewatering pad was designed to accommodate up to 13,716 lineal m (45,000 lineal ft) of geotextile tubes, providing about 221,721 m³ (290,000 yd³) of capacity with geotextile tubes stacked in six layers over an area approximately 229 m by 180 m (750 ft by 590 ft). In fact, about 11,582 lineal m (38,000 lineal ft) of geotextile tubes, stacked in five layers, were filled in the non-TSCA pad, containing about 172,789 in-situ m³ (226,000 in-situ yd³) of material.



Figure 5. Non-TSCA dewatering pad with geotextile tubes stacked in 5 layers.

In order to match the existing elevations of the landfill, the non-TSCA pad was designed with a two tiered surface. The terraced dewatering pad limited the capacity of the second layer of the geotextile tubes filled on the lower tier, but this slight reduction in capacity was necessary to produce a level surface for stacking the three layers above. Overall, the design worked well, and reduced the total cost to the client.

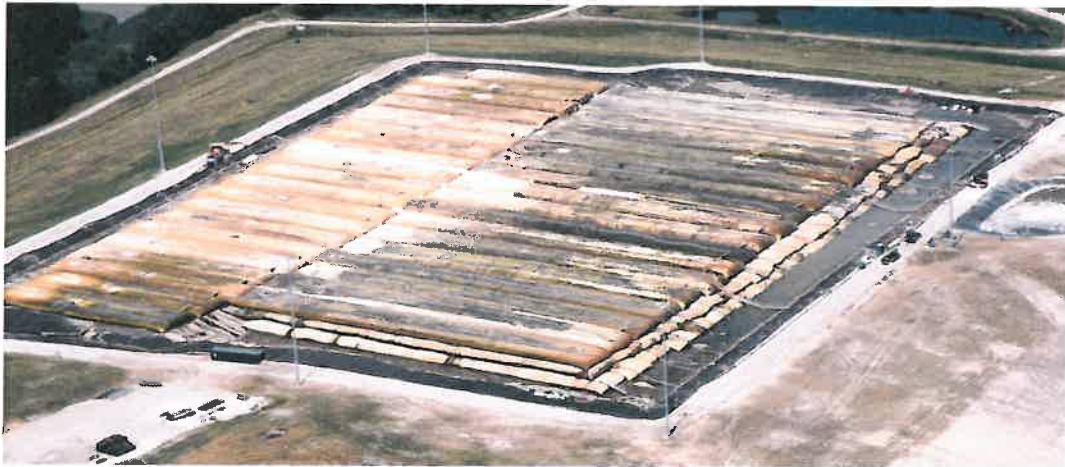

Figure 6. Aerial view of the non-TSCA dewatering pad showing the tiered surface.

The non-TSCA pad was installed over a new landfill cell. The filled geotextile tubes will remain in place and be covered with fill as part of the closure of that cell.

GEOTEXTILE TUBE DEWATERING OF TSCA REGULATED SEDIMENTS

TSCA sediments were dredged intermittently with 33 total days of dredging taking place over a two month period. TSCA dredging was performed concurrently with non-TSCA, so separate crews performed dewatering operations on both non-TSCA and TSCA dewatering pads simultaneously.

TSCA sediments were not screened or thickened prior to dewatering in geotextile tubes because of the relatively low volume of TSCA material to be handled during the course of this project. TSCA material was pumped from the dredge directly to the geotextile tubes in the TSCA dewatering pad.

The TSCA dewatering pad was designed to hold 11,468 m³ (15,000 yd³) of dredged material in 655 lineal m (2,150 lineal ft) of 24 m (80 ft) circumference geotextile tubes, stacked in two layers. The actual volume of material received at the TSCA pad was nearly 12,233 m³ (16,000 yd³), which required some redesign of the tube layout scheme and the addition of 104 lineal m (340 lineal ft) of geotextile tubes.



Figure 7. TSCA dewatering pad during active dewatering operations.

WATER TREATMENT

Sumps were installed in each dewatering pad to receive water released from the geotextile tubes and stormwater. The non-TSCA sump flowed by gravity to the WTP for treatment; the TSCA sump was transferred by a 20 cm (8 in) diameter diesel pump.

The WTP incorporated three treatment processes: flocculation, coagulation and settling; two step filtration; and Granular Activated Carbon (GAC) adsorption. These processes removed suspended and colloidal solids and dissolved organic contaminants (such as PCBs) from the flow of water.



Figure 8. Aerial view of the WTP equipment during operations.

Flocculation, Coagulation and Settling

During normal dredging operations, the WTP received about 11,356 L/min (3,000 gal/min) of influent from the dewatering pads and the sediment thickener. Flocculation, coagulation, and settling of suspended solids were achieved using seven inclined plate separators (lamella clarifiers) arranged in parallel. The chemical coagulant used was ferric chloride (FeCl_3). The angle of the inclined plates in the lamella clarifiers enhance settling of coagulated floc. Effluent from the lamella clarifiers was monitored for turbidity, and then flowed to four 79,494 L (21,000 gal) frac tanks, which served to equalize the flow from the lamella clarifiers prior to further treatment.

Filtration

A 149 kW (200 HP) electric drive pump was used to draw water from the frac tanks and transfer it to five multi-media pressurized filters (operated in parallel). The filter beds included three sizes of filter gravel, filter sand and anthracite. Pressure drop across the filters was monitored to determine when backwashing was required. The multi-media filters were piped so that one filter could be backwashed while the others remained in service. The backwash was equipped with a hydrogen peroxide feed to help remove sticky buildup in the media.

Filtered water exited the multi-media filters and flowed through a common pipe to the bag filters, where the flow was split again, among the three units. Bag filters physically separate solids from the flow as the water passes through filtering fabric (bags). The bag filters acted as a buffer to protect the downstream GAC vessels from solids which would foul the GAC media and shorten its service life.

GAC Adsorption

GAC adsorption was the final process utilized in the WTP. The GAC was used to remove any remaining organic contaminants (such as PCBs) in the flow before it was discharged to the Ottawa River. A total of ten GAC vessels were arranged in five pairs of lead-lag units. Each vessel was loaded with 9,072 Kg (20,000 lbs) of GAC and was sized to treat up to 3,785 L/min (1000 gal/min). The turbidity and pH of the GAC effluent was closely monitored to verify water quality before discharge to the river. Differential pressure across the vessels was monitored to determine when backwashing was needed.

A side stream from the GAC vessels was used to fill three 21,000 gal frac tanks. This water was used for backwashing, polymer makedown and as mechanical seal water for the last dredge booster pump station.

Treatment Residuals

The WTP was situated on a gravel pad with a clay liner. The lamella clarifiers were installed on a concrete pad within the footprint of the larger gravel pad. The concrete lamella pad was constructed with berms and also had a sump for collection of lamella sludge. Water treatment residuals (lamella sludge, filter and GAC backwash water) were transferred to a waste tank, and then pumped to a geotextile tube in one of the two sediment dewatering pads (depending on whether or not TSCA dredging was on-going; during periods of TSCA dredging, water treatment residuals were directed to the TSCA pad for dewatering). After TSCA dredging was completed, water in the treatment plant waste tank was tested for PCBs to verify the contents were below TSCA levels before the contents of the tank could again be pumped to the non-TSCA pad for dewatering.

NPDES Permit Monitoring

The NPDES permit issued for the project set forth effluent limitations for Total Suspended Solids (TSS), pH, total PCBs and Total Filterable Residue (TFR), along with a rigorous sampling and analysis regimen. An Ohio Class 3 licensed operator served as Operator of Record for the facility.

CHALLENGES OF THE PROJECT

Fast Tracked Water Treatment Plant Design and Construction

The initial project schedule called for construction of the WTP and sediment dewatering pads, as well as dredging and dewatering of the TSCA sediment to be completed in the fall of 2009, with dredging and dewatering of the non-TSCA sediment to be completed in 2010. For a number of reasons, the project was delayed until the 2010 dredging season and needed to be completed within that calendar year.

As a result of this compressed schedule, WTP design was scaled back to achieve one season operation, with the installation and start-up of the systems to be completed in 60 days. A combination of used and rented equipment would be placed on a gravel pad with a small building to house controls. IAI engineering and dewatering operations staff worked together to update the design and draw plans for a more economical system that would meet the challenge of the new design parameters.

Non-TSCA and TSCA Dredging Operations Conducted Concurrently

In order for the non-TSCA and TSCA dredging operations to be conducted simultaneously, each dewatering system had to be fully separate and independently functioning. Special considerations had to be made for handling water treatment residuals during TSCA dredging. Crew strength had to be great enough to operate each system successfully without negatively impacting either dredging or water treatment operations.

TSCA Material Hauled Off-Site After Minimal Dewatering Time

The Hoffman Road Landfill where landside operations took place is a municipal landfill owned by the City of Toledo. It is not licensed to accept TSCA regulated waste. The geotextile tubes in the TSCA dewatering pad had to be transferred off site to a TSCA licensed landfill for final disposal. It was desired that the TSCA material be hauled off site beginning in November 2010. The last day of TSCA dredging was September 8, which left minimal time for the TSCA tubes to dewater.

The TSCA geotextile tube contents were too wet to be accepted at the TSCA landfill initially. In order to make the material easier to handle and acceptable at the landfill, IAI began mixing lime kiln dust with the TSCA material. Although concerns arose about the compressive strength of the material, it was eventually found to be >50% non-cohesive material and was only required to pass a slump test. IAI began performing slump tests at 30 minute intervals using a standard slump cone (ASTM C 143). None of the slump tests performed on site failed. As weather permitted, IAI continued mixing lime kiln dust into the TSCA material at a rate to keep prepped material ready for the hauling contractor until the task was complete on December 14. In all, IAI added about 907 metric tons (1,000 U.S. tons) of lime kiln dust to the TSCA sediment prior to its being hauled off site for final disposal.

Cold Weather Demobilization

Dredging and active sediment dewatering operations ceased on October 21, 2010. Operation of the WTP continued until December 21, with decontamination and demobilization wrapping up January 26, 2011. Freezing temperatures and icy conditions made demobilization difficult and increased the risk of personnel injury.

To prevent cold stress and related injuries, crews utilized electric and propane space heaters where possible, as well as personal hand and foot warmers and additional cold weather clothing. Personnel also began taking warm-up breaks in the heated office trailers.

To keep the WTP pipelines and equipment from freezing, water was continuously circulated through the plant. Heat tape was used to protect fragile sample ports and propane torches and torpedo heaters were used to thaw any valves that did freeze. All of these measures took time and patience to execute, but were absolutely necessary to accomplish the decontamination and removal of equipment from the site during the winter months.

SUMMARY AND CONCLUSIONS

Landside operations for the Ottawa River Sediment Remediation Project were completed successfully during the winter of 2010 – 2011. Highlights include:

- While logging 77,600 man hours during performance of the project, IAI personnel experienced no OSHA recordable injuries or illnesses.
- Ninety-six percent (96%) up time efficiency was achieved for sediment dewatering and WTP operations.
- Dredging and active dewatering operations finished ahead of schedule.
- No NPDES permit effluent quality limitations were violated while the WTP was in operation.

There were several critical factors that led to the ultimate overall success of both the sediment dewatering and water treatment operations. Those factors include:

- **Leadership:** The project sponsors, the Ottawa River Group (ORG) and the United States Environmental Protection Agency (USEPA) Region 5, along with the project coordinator, de maximis, inc., fostered a spirit of cooperation and accountability among all of the contractors involved. This created a true team atmosphere, which increased efficiency across the board and allowed contractors to work together to solve problems for the benefit of the project as a whole.
- **Communication:** Open, honest communication among the project team was critical to planning for, identifying and successfully handling challenges. Close communication among the sediment thickener, dewatering pad and WTP personnel was also crucial to maintaining tight control of the dewatering system as a whole.
- **Experience:** Involving as many experienced personnel as possible from previous large scale sediment dewatering projects allowed us to benefit from lessons learned during those previous projects and build many of those lessons into standard operating procedures and contingency plans for the Ottawa River project.
- **Process control:** Traditional water treatment process control techniques were used to meticulously monitor and manage chemical conditioning in order to achieve desired sediment dewatering in the geotextile tubes and at the same time, protect the WTP from residual polymer.
- **Adaptive system design:** The sediment dewatering system was designed to allow six different modes of operation. Under normal operating conditions, non-TSCA dredge flow was processed by the sediment thickeners and could be sent to either the east or the west side of the non-TSCA dewatering pad, or to both sides simultaneously. If a pump malfunctioned or required maintenance, the sediment thickeners could be bypassed and dredge flow could be run directly into the east, west, or to both sides of the non-TSCA dewatering pad. This arrangement enabled full scale dewatering operations to continue even while maintenance was being performed. Efficiency on the Ottawa River project was very high, which can partially be attributed to the adaptive design of the sediment dewatering system, reducing the effect of sediment dewatering on dredge up time.
- **Coordination:** Working closely together as a team, many subcontractors came together to design and install a water treatment system made up of many separate used and rented pieces of equipment.

- Personnel: Not enough can be said about the devoted and hardworking crews who put in long hours making this project a success on a day to day basis.

ACKNOWLEDGEMENTS

The Ottawa River Sediment Remediation project was accomplished by a large team of government agencies, private companies and contractors, each with a pivotal role. The author wishes to acknowledge: the project coordinator, de maximis, inc.; the non-federal project sponsor, the ORG; and the federal sponsor, USEPA Region 5 Great Lakes National Program Office.

CITATION

Cretens, W.J. "Dewatering and water treatment operations of the Ottawa River sediment remediation project," *Proceedings of the Western Dredging Association (WEDA XXXI) Technical Conference and Texas A&M University (TAMU 42) Dredging Seminar*, Nashville, Tennessee, June 5-8, 2011.

WATER MANAGEMENT DURING MECHANICAL DREDGING OF CONTAMINATED SEDIMENT

Paul F. Fuglevand¹, Robert S. Webb²

ABSTRACT

This paper addresses the contribution of barge overflow water generated during mechanical dredging of contaminated sediment to the formation of a residual sediment layer in the work area. First it presents a method to estimate the amount of water generated by mechanical dredging and then presents a case study of a water management system at an environmental dredging project that captured suspended solids from barge water prior to discharge back to the water body. The findings of the case study document that barge overflow can be a significant contribution to the formation of a residual layer of sediment at a mechanical dredging project.

Key Words: Barge overflow, residual layer, fill factor, captured water ratio, geotubes.

INTRODUCTION

Environmental dredging is one of three primary options for the remediation of contaminated sediment, in addition to capping and monitored natural recovery. In recent years the significance of sediment resuspension during dredging, contaminant release because of dredging, residual contamination remaining after dredging, and environmental risk associated with dredging (the "4Rs") have become important considerations in the evaluation of the effectiveness of environmental dredging. Reduction of the 4R's improves the environmental effectiveness of sediment remediation. This paper presents information on water management techniques for mechanical dredging of contaminated sediment that result in the reduction of contaminant release and residual layer formation due to dredging.

Conventional mechanical dredging techniques developed for navigation projects can and will suspend and release sediment into the water column, which can result in the accumulation of residual sediment in the work area. Two significant mechanisms of sediment release during mechanical dredging are 1) the erosion of sediment from the bucket as it is raised through the water column, and 2) the overflow of turbid water from the sediment haul barge (the topic of this paper).

From a navigation dredging perspective, the accumulation of a relatively thin layer of residual sediment on the bottom does not adversely impact the objective of the work, which is to lower the bottom to an acceptable elevation for ship traffic. From an environmental remediation perspective, the accumulation of a relatively thin layer of contaminated residual sediment can significantly impact the success of the action. This is because the surface layer of sediment is a primary zone of biological activity in an aquatic environment. Sediment quality criteria are often focused on the top few inches of material in a waterway, and the accumulation of a few-inch thick residual layer of contaminated sediment following dredging can be adverse to aquatic animals and the ultimate success of the project.

WATER CAPTURED IN A CLOSED MECHANICAL BUCKET

The analysis in this paper assumes the use of closed dredging buckets, which are becoming widely used and often required for sediment remediation. The two halves of a closed bucket are designed such that when brought together fully they form a closed container that isolates the material in the bucket from the water column. This isolation generally eliminates erosion of sediment from within the bucket while the bucket is being lifted through the water column. Because the bucket is closed, it also retains the water captured in the bucket until the contents are placed into the barge. Consequently a closed bucket will normally deliver a fixed volume of material into the barge, which can be at various proportions of water and sediment. For example, a 4.6 cubic meters - cu m (6 cubic yard - cy) closed bucket that is half full of sediment will contain 2.3 cu m (3 cy) of sediment and 2.3 cu m (3 cy) of water. That same bucket only 1/3 full of sediment will deliver 1.5 cu m (2 cy) of sediment and 3.1 cu m (4 cy) of water into

¹ P.E., Dalton, Olmsted & Fuglevand, Inc., 10827 NE 68th Street, Suite B, Kirkland, Washington, 98033, USA, phone 425 827-4588, fax 425 739-9885, email pfuglevand@dofnw.com

² P.E., Dalton, Olmsted & Fuglevand, Inc., 10705 Silverdale Way NW, Suite 201, Silverdale, WA, 98383, USA, phone 360 692-7345, fax 360 692-1895, email rwebb@dofnw.com

the barge. Closed buckets used for dredging have some type of vent at the top of the bucket that allows water and air to escape as the bucket is lowered thru the water column. These vents are typically closed by a rubber flap or similar device during bucket ascent thru the water column.

Overfilling the bucket is normally avoided during environmental dredging to limit the suspension of sediment in the water column from the dredging process. This requires individual bucket cuts that generate less than a full bucket of sediment. This results in more water being generated during environmental dredging as compared to navigation dredging, where fuller buckets are typically desired.

The degree to which a dredging bucket is filled by sediment is called the bucket Fill Factor (F_f). It is expressed as the volume of sediment captured in the bucket (V_{cs}) divided by the capacity of the bucket (V_b).

$$\text{Fill Factor} \quad F_f = V_{cs}/V_b \quad (1)$$

A 4.6 cu m (6 cy) bucket filled half full of sediment would have a fill factor of 0.5 (3 cy sediment / 6 cy capacity). The same bucket 1/3 full of sediment would have a fill factor of 0.33 (2 cy / 6 cy). The fill factor can be used to estimate production rates for mechanical dredging. The parameter will vary project to project and site to site dependent on many parameters including thickness of cut, bucket size & type, material type, and operator skills.

Higher fill factors are possible with easily dug material. For example, the fill factor for a digging bucket in a full bank of loose sand might be on the order of 1, while the fill factor for the same bucket and operator digging hard sand or stiff clay might be only 0.4. This would generally be due to the inability of the bucket to penetrate the harder material. The fill factor also drops as the thickness of dredge cut becomes less than is needed to fill the bucket. For example, the fill factor for digging a 0.3 m (1 ft) thick layer of sand might be only 0.3 as compared to 0.8 for digging a 1.2 m (4 ft) thick layer of sand with the same operator and bucket. This is because in the first case, the operator would attempt to limit penetration to prevent over-dredging beyond the desired depth whereas in the second case, there may be sufficient bank thickness that the operator can let the bucket dig to its full depth.

Because environmental dredging often involves the removal of relatively thin layers of sediment, the associated bucket fill factors are typically less than associated with navigation dredging. Consequently sediment remediation dredging can generate considerably more water in the bucket and hence in the haul barge than is associated with navigation dredging.

While the fill factor describes how much sediment is captured in a mechanical bucket, another term can be used to describe the amount of water captured in a mechanical bucket, the Captured Water Ratio (R_{cw}). It is the ratio of the volume of captured water in a bucket (V_{cw}) to the volume of captured sediment (V_{cs}) in a bucket.

$$\text{Captured Water Ratio:} \quad R_{cw} = V_{cw} / V_{cs} \quad (2)$$

This paper assumes the use of closed buckets, which means the volume of captured water (V_{cw}) plus the volume of captured sediment (V_{cs}) equals the volume of the bucket (V_b).

$$\text{Closed Bucket Volume:} \quad V_b = V_{cw} + V_{cs} \quad (3)$$

For example, a 4.6 cu m (6 cy) bucket filled half full of sediment would hold an equal volume of water and would have a captured water ratio of 1 (3 cy water / 3 cy sediment). Based on the relationship between V_{cw} and V_{cs} (3), and the definition of bucket fill factor (1), the captured water ratio can be re-written as a function of the fill factor.

$$\text{Captured Water Ratio:} \quad R_{cw} = (1-F_f) / F_f \quad (4)$$

Given the average fill factor for a project, the total volume of water captured by the bucket and placed in the barge (V_{dw}) from dredging the in-situ volume of project sediment (V_{ds}) can be estimated as V_{ds} times the average captured water ratio.

$$\text{Volume of Dredged Water:} \quad V_{dw} = R_{cw} * V_{ds} \quad (5)$$

Assuming that all of the material captured in the bucket goes into the barge, the volume of dredged material (V_{dm}) in the barge is the sum of the in-situ volume of sediment dredged (V_{ds}) plus the volume of dredged water (V_{dw}).

Volume of Dredged Material:

$$V_{dm} = V_{ds} + V_{dw} \quad (6)$$

$$V_{dm} = V_{ds} + R_{cw} * V_{ds} \quad (7)$$

$$V_{dm} = V_{ds} (1 + R_{cw}) \quad (8)$$

Based on the above, the captured water ratio can be used as a basis to estimate the total volume of water that will be captured by the bucket and then managed during a mechanical dredging project. For example, if the anticipate fill factor for a 4.6 cu m (6 cy) bucket is 0.66 for the site conditions at a 76,000 cu m (100,000 cy) (in-situ) dredging project, then the captured water ratio would be 0.5, the volume of dredged water would be 38,000 cu m (50,000 cy), and the volume of dredged material (as loaded into the barge) would be 114,000 cu m (150,000 cy), as shown below.

GIVEN

$V_b = 6$ cy (4.6 cu m) closed bucket

$F_f = V_{cs} / V_b = 4/6 = 0.66$

CALCULATE

$V_{cs} = F_f * V_b = 0.66 * 6$ cy = 4 cy sediment

$V_{cw} = V_b - V_{cs} = 6$ cy – 4 cy = 2 cy water

$R_{cw} = V_{cw} / V_{cs} = 2/4 = 0.5$ or

$R_{cw} = (1 - F_f) / F_f = (1 - 0.66) / 0.66 = 0.33 / 0.66 = 0.5$

APPLY

$V_{ds} = 100,000$ cy (76,000 cu m) in-situ sediment

$V_{dw} = V_{ds} * R_{cw} = 100,000$ cy * 0.5 = 50,000 cy (38,000 cu m) dredged water

$V_{dm} = V_{ds} + V_{dw} = 100,000$ cy + 50,000 cy = 150,000 cy (114,000 cu m) dredged material, or

$V_{dm} = V_{ds} (1 + R_{cw}) = 100,000$ cy (1 + 0.50) = 150,000 cy dredged material

Table 1 presents this calculation for bucket fill factors ranging from 0.2 to 1.0. While the in-situ volume of dredged sediment remains constant at 76,000 cu m (100,000 cy), the volume of dredged water increases from 0 at a fill factor of 1, to 305,000 cu m (400,000 cy) at a fill factor of 0.2. At the same time the total volume of dredged material placed in the barges goes from 76,000 cu m (100,000 cy) at a fill factor of 1 to 380,000 cu m (500,000 cy) at a fill factor of 0.2. While a project average fill factor of 0.2 is not likely, there may be portions of a project where the fill factor can be as low as 0.2, such as when thin lifts of sediment are being removed in the final stage of cleanup. These estimates of captured water can be used to plan water management facilities.

Table 1. Dredged volumes as a function of bucket fill factor.

F_f	R_{cw}	Sediment V_{ds} (cy)	Water V_{dw} (cy)	Total V_{dm} (cy)
1	0	100,000	0	100,000
0.8	0.25	100,000	25,000	125,000
0.7	0.43	100,000	43,000	143,000
0.6	0.67	100,000	67,000	167,000
0.5	1	100,000	100,000	200,000
0.4	1.5	100,000	150,000	250,000
0.3	2.3	100,000	233,000	333,000
0.2	4	100,000	400,000	500,000

CASE STUDY - WATER MANAGEMENT DURING ENVIRONMENTAL MECHANICAL DREDGING AT HEAD OF HYLEBOS WATERWAY

Table 1 indicates the magnitude of water that can be generated by a mechanical dredging project. However little data is available on the average fill factor associated with sediment remediation by mechanical dredging. The following discussion presents a description of the water management system utilized during late 2005 and early 2006 for the mechanical dredging at the head of Hylebos Waterway, part of the Commencement Bay / Nearshore Tidelates Superfund Site at Tacoma, Washington.

Dredging Project

Dredging of approximately 65,000 cy (50,000 cu m) of impacted sediment was performed using two dredges. The majority of the dredging was completed by Envirocon, Inc. of Portland, Oregon using an articulated fixed-arm dredge (Komatsu 750 excavator on a barge) with a 2.3 cu m (3.0 cy) closed hydraulic clamshell bucket (Figure 1). The clamshell was manufactured by Young Corporation of Seattle, Washington. A smaller portion of the dredging was completed by Quigg Bros., Inc. of Aberdeen, Washington from a crane barge using both a conventional rehandling clamshell bucket (2 ½ cy, 1.9 cu m) and a Cable Arm closed bucket (4 cy, 3 cu m). In all cases the dredged material was placed into flat-deck barges with water tight four-foot side walls (250 cy, 190 cu m capacity) for transport to an on-site dock for offloading. The dredged material was removed from the barges using a hydraulic excavator (Komatsu 600) on the dock equipped with a Young hydraulic clamshell bucket. The dredge material was trans-loaded into containers on rail cars that passed along the edge of the dock for delivery to the Regional Disposal Company landfill in eastern Washington.



Figure 1. Young's closed hydraulic clamshell bucket for articulated fixed-arm dredge.

Water Management

The water management system consisted of a barge dewatering system, sediment capture system, and discharge system back to the waterway as dredging return water. The barge dewatering system consisted of a Godwin 4-inch (0.1 m) diameter discharge submerged centrifugal pump deployed from a 20-ton crane located on a small work barge (Figure 2). The work barge was normally positioned alongside the sediment barge while it was being loaded by the dredge. The pump was submerged into the accumulated water in the sediment barge and turbid water was pumped through a 0.1 m (4 inch) diameter HDPE floating line to the upland sediment capture system. The operation focused on removing as much water as practical from the barge, without removing the underlying sediment in the barge. This was done to prevent barge overflow and increase barge capacity for sediment as well as reduce the volume of water that became entrained in the sediment.

At the upland sediment capture system the turbid water that was pumped from the barges entered a settling chamber to separate sand sized and larger particles. The overflow from the settling chamber was pumped into one of four 70 cu m (18,000 gallon) mixing tanks supplied by Rain for Rent (Figure 3). Each mix tank of turbid water was managed on a batch basis. A grab sample of the turbid water was collected from each tank and tested with polymer

(Nalco # 7768) to determine proper dosing. The required amount of polymer/water blend was then added to the tank and gently mixed for a few minutes as the fine grained sediment formed sand sized floc. The flocculated material was then pumped to one of three Mirafi Geotubes (18 m (60-ft) circumference by 30 m (100 ft) long) for separation of the sediment and the water (Figure 4). The flocculated sediment was retained in the Geotube, while the clarified water passed through the non-woven geotextile wall of the tubes.



Figure 2. Barge dewatering system.



Figure 3. Mixing tanks, upland sediment capture system.



Figure 4. Geotubes with mixing tanks in background.

The water passing the Geotube was then pumped into a holding lagoon, from which it was pumped through sand filters and bag filters (Rain For Rent) prior to discharge back to the waterway (Figure 5).



Figure 5. Sand filters (center) and bag filters (right) prior to discharge to waterway.

Dredged Water

The volume of dredged water (V_{dw}) generated by the dredge is estimated as the sum of the volume of the water pumped from the barge (V_{pw}) and the volume of water entrained in the sediment in the barge (V_{ew}).

$$\text{Volume of Dredged Water:} \quad V_{dw} = V_{pw} + V_{ew} \quad (9)$$

The entrained water was offloaded with the sediment and shipped to the landfill for disposal. The degree to which water is entrained into the sediment is dependent on several factors, including sediment type, the type of bucket used for dredging, the method of operating the equipment, the manner in which sediment is placed into the barge, as well as the water capture methods. Preliminary analysis of project data indicates that the volume of entrained water was on the order of 15% to 20% of the in-situ volume of dredged material.

Estimated Quantities

The estimated quantities of dredged sediment, captured water, and captured sediment for the Head of Hylebos sediment remediation project for the 2005-2006 construction season are summarized below.

Table 2. Dredging and water management approximate quantities, head of Hylebos sediment remediation. 2005-2006 Construction Season.

Parameter	Value	
#1. In-situ volume of dredged sediment (V_{ds})	65,000 cy	50,000 cu m
#2. Volume of water pumped from barges (V_{pw})	75,000 cy	57,000 cu m
#3. Volume of entrained water (V_{ew})	10,000 cy	8,000 cu m
#4. Volume of dredged water (V_{dw}), (= #2 + #3)	85,000 cy	65,000 cu m
#5. Volume of dredged material (V_{dm}), (= #1 + #4)	150,000 cy	115,000 cu m
#6. Volume of sediment captured in Geotubes	4,000 cy	3,000 cu m
#7. Captured water ratio (R_{cw}), (= #4/#1)		1.3
#8. Average fill factor (F_f), (= #1/#5)		0.4

The water management system processed an estimated 57,000 cu m (75,000 cy) of turbid water pumped from the sediment barges (V_{pw}) that came from the dredge buckets. When processed, the 57,000 cu m (75,000 cy) of turbid water produced on the order of 3,000 cu m (4,000 cy) of sediment in the Geotubes. The 3,000 cu m (4,000 cy) of solids represents approximately 2.5% solids by weight in the 57,000 cu m (75,000 cy) of captured turbid water. The 3,000 cu m (4,000 cy) of sediment collected in the Geotubes represents approximately 6% of the in-situ volume of

dredged sediment. It also represents a potential 0.07 – 0.1 m (3 to 4 inch) thick layer of very fine grained residual sediment, had the turbid water been allowed to overflow the barge and the suspended solids settle back to the bottom in the dredge area rather than be captured and processed.

CONCLUSIONS

The volume of material placed in a barge by a mechanical dredge using a closed bucket will consist of both sediment and water, with the potential for water volumes to equal or exceed the in-situ volume of sediment dredged. Discharging the captured water back to the waterway as barge overflow water will often result in the release of sediment back to the dredged area and the formation of a residual layer of sediment over the dredged surface. There is also potential for offsite migration of the sediment, producing a residual layer outside the original project area.

The average bucket fill factor for a given project is a function of several conditions, including the size and configuration of the bucket, the nature and thickness of the dredge cuts and sediment, and the attributes of the dredge operator. The average bucket fill factor can be used to estimate the amount of water that will be produced by a mechanical dredging project, expressed as a function of the in-situ volume of sediment to be dredged.

Recent data collected during mechanical dredging with a closed bucket at the Head of Hylebos Waterway in Tacoma, Washington documented that more water than sediment was delivered to the barge by the closed bucket (an estimated 65,000 cu m (85,000 cy) water and 50,000 cu m (65,000 cy) of sediment). Of the 65,000 cu m (85,000 cy) of dredged water, an estimated 8,000 cu m (10,000 cy) was entrained in the dredged material and shipped to a regional landfill for disposal. Processing of the 57,000 cu m (75,000 cy) of water pumped from the sediment barge resulted in the capture of a volume of sediment (4,000 cy, 3,000 cu m) roughly equal to 6% of the in-situ dredged volume. If the turbid water in the sediment barge had been allowed to overflow back into the waterway, it would have released enough sediment to form a 0.07 – 0.1 m (3 to 4 inch) thick layer of residual sediment on the bottom of the entire dredged area.

With proper management of barge overflow a significant quantity of contaminated sediment can be captured that would otherwise be released and accumulate in a residual layer (several inches thick) on the bottom of the water body. Failure to capture and manage barge overflow water will add to the environmental risk associated with dredging and potentially result in failure to achieve the project cleanup objectives.



www.itrcweb.org

Mining Waste Treatment Technology Selection

- ▶ ITRC

- ▶ ITRC Mining Waste Public Page

- ▶ ITRC Mining Waste Guidance Home Page

- ▶ Decision Tree

- ▶ Technology Overviews

- ▶ Case Studies

- ▶ Regulatory Issues

- ▶ Stakeholder Values and Concerns

- ▶ Additional Resources

- ▶ Appendices

- ▶ Tutorial

- ▶ Site Map

▶ Contact Us

- ▶ Feedback

- ▶ Printer Friendly Version

Technology Overview as part of a Web-based Technical and Regulatory Guidance

Electrocoagulation

1. Introduction

[Click Here](#) to view case study table at the end of this document.

Electrocoagulation (EC) generally refers to a group of technologies which use an electrical current that coagulates organic constituents and suspended solids in water. The coagulated organics have the ability to adsorb certain ionic constituents, making it possible to separate a flocculent with a majority of the suspended organics and some of the ionic constituents removed. Another variant of this system oxidizes an iron or aluminum anode to form an iron or aluminum hydroxide flocculent which can co-adsorb/co-precipitate some ions. This variant works well only in near-neutral (pH) solutions. Multiple mechanisms have been claimed for removal of contaminants from water.

EC is an active process that involves three major parts:

1. The reaction chamber containing multiple anode and cathode pairs through which the contaminated water passes. The electrodes can be designed as plates, perforated plates, or tubes. They can be composed of different materials, including aluminum, iron, stainless steel, and titanium. A series of reaction chambers can be used, each with different electrode material.
2. The electrical system, composed of control electronics. The current passed to the electrodes is often designed to be alternating (AC). Typically direct current (DC) is required, although using alternating current (AC) technology may prevent formation of an oxide layer on the cathode.
3. A system to dewater the precipitated/coagulated solids. This system could be similar to any used in conventional chemical precipitation processes.

2. Applicability

The Mining Waste Team has found that electrocoagulation may have certain niche applications where the technology may be effective, including near-neutral waters where co-precipitation with iron hydroxide could polish relatively clean waters. Potential applications include the following:

- final treatment and polishing of discharge water from a high-density sludge water treatment plant to remove residual colloidal material and metals.
- pre-treating water prior to [Pressure-Driven Membrane Separation](#) to remove colloidal silica and metals near saturation.
- treating neutral tailings water to remove minor amounts of metals prior to discharge (generally will not be successful treating total dissolved solids (TDS) or sulfate in this type of water)

Prior testing of these applications must be conducted to verify the performance with each water type.

3. Advantages

Advantages of this technology include the following:

- potentially recoverable metals
- reuse of treated effluent

Electrocoagulation is an alternative to chemical precipitation for the removal of dissolved and suspended metals in aqueous solutions (see [Chemical Precipitation Technology Overview](#)).

The quantity of sludge produced is lower. The floc generated is larger and heavier and settles out better than in conventional chemical precipitation processes. Since a large thickener is not required, capital costs can also be lower. The effluent generated by electrocoagulation contains no added chemicals and is often of better quality, containing TDS and less colloidal particulates. Reduction of TDS has been reported at 27%–60%, and reduction of total suspended solids can be as great as 95%–99% (Powell Water Systems 2009).

Although electrocoagulation requires energy input, it requires only low currents and can be operated using green technologies such as solar or wind power.

4. Limitations

- high cost
- active
- unproven
- regular replacement of electrodes

The electrocoagulation process is complex. No set configuration is applicable to all needs, and many parameters need to be adjusted for optimal treatment. This includes electrode materials; electrode design; electrode gap; consistent or alternating polarity; current density; flow configuration; retention time; etc. Properties of the wastewater being treated, including conductivity, pH, chemical concentrations, and particle size, also affect the efficiency of the electrocoagulation treatment process.

5. Performance (Results)

For electrocoagulation to be an effective treatment technique, the conductivity of the contaminated water must be high. The treatment has also been demonstrated to work more efficiently when lower concentrations of pollutants are present and when the pH is between 4 and 8 (Adhoun et al. 2004). Electrocoagulation can induce an increase of pH, which may make the treated wastewater alkaline. The induced pH may be as high as 9 or 10. The pH increase is likely the result of excess hydroxyl ions at the cathode due to the reduction of water. The increase in pH is controlled while there are metal ions being precipitated as metal hydroxides. When the concentration of metal ions is low enough, the increase in pH occurs. Electrocoagulation will not treat the majority of impacted water at metal mining sites. Acidic waters are unaffected by electrocoagulation, and most base metal mine water have no organic constituents. When the iron/aluminum anode of the EC system is oxidized in acidic conditions, no flocculent is formed because iron and aluminum are soluble below pH 3. It appears that electrocoagulation does not remove sulfate from sulfate impacted waters.

Although removal rates of metals such as copper and zinc are quite high, the removal of some contaminants such as chromium or silver may require long retention times, depending

on the initial concentrations of the pollutants. The removal of chromium and silver is aided by the presence of other metals due to co-precipitation. In the presence of chlorides and organic pollutants, it is possible the electrocoagulation process can oxidize the chlorides and chlorinate the organics into toxic substances.

A mine technology group tested electrocoagulation in 2008 in conjunction with an electrocoagulation technology provider. Mining-influenced water (MIW) was sent to an outside group that was experienced with testing electrocoagulation. While there was some coagulation and reduction of aqueous solutes observed during testing, the testing group was unable to provide a mass balance for their work, and the work was discontinued (Willow Creek Reclamation Committee 2006).

Electro-Pure Systems, Inc. conducted a Superfund Innovative Technology Evaluation (SITE) demonstration in the early 1990s using alternating current electrocoagulation (ACE) (Barkley, Farrell, and Williams 1993). The ACE project demonstrated variable metal removal efficiencies as operating parameters changed. Removal rates were reported at 66%–96% for lead, 90%–100% for copper, 87%–94% for chromium, and 14%–99% for cadmium. The lower removal percentages were seen when treating water containing high concentrations of metals (Barkley, Farrell, and Williams 1993).

An experimental treatment system was conducted at Aachen University, Germany, during 2006. The wastewater tested was from a Serbian mining and smelting complex and contained high concentrations of copper (50 mg/L), aluminum (13 mg/L), and manganese (6 mg/L). The wastewater also had a low pH (4.3) and contained elevated sulfates (560 mg/L). The results of the experiment were favorable, with an increase in pH to 7 and excellent metal removal efficiencies (Cu = 99.9%, Al = 97.7%, Mn = 99.7%). In their technical paper, the authors concluded, “Electrocoagulation may prove to be not only feasible and economically friendly, but also technically and economically superior to conventional technology like chemical precipitation” (Rodriguez et al. 2007).

Electrocoagulation treatment of wastewater from a copper smelting facility was studied by the Central Electrochemical Research Institute in India. The wastewater was characterized by a low pH (0.64–0.88) and contained elevated concentrations of As (1979 mg/L), Cu (164 mg/L), Cd (76 mg/L), and Zn (4565 mg/L). The wastewater was continuously circulated through a flow cell containing a stainless steel plate as the cathode and titanium mesh as the anode. It was noted that the effluent turned a black color due to the precipitation of metal sulfides as sulfate was reduced at the cathode. Maximum removal efficiencies ranged from

73.8% (Cd) to 98.8% (Cu). The overall energy requirement was 10.99 kWh/kg of total heavy metal removed (Basha et al. 2007).

6. Costs

Very little cost information is available. Much of the pilot work that has been conducted using electrocoagulation processes for treatment of metal-containing wastewaters has speculated that costs could be very competitive with traditional chemical precipitation. It is probable that design costs could be quite high, given that the process efficiency is dependent on complex site-specific parameters (see Section 4). A potential cost advantage of the electrocoagulation process is the generation of a lesser amount of sludge. The sludge is generally easier to dewater and may be beneficially recovered.

7. Regulatory Considerations

Metal removal rates indicate that electrocoagulation should be able to achieve regulatory limits. A National Pollutant Discharge Elimination System permit would be required to allow discharge of the treated effluent. Electrocoagulation is not a proven technology for full-scale treatment of mining wastes. This fact may cause difficulties when obtaining regulatory approval/acceptance of its use.

8. Stakeholder Considerations

Several benefits to electrocoagulation may make it acceptable to the public. The ability to recover metals and reuse the effluent makes the electrocoagulation process a good alternative to traditional chemical precipitation technologies. The amount of potentially hazardous sludge generated requiring disposal is also reduced. Green sources of energy could be used to supply the relatively low power demand.

9. Lessons Learned

The electrocoagulation process is site and contaminant specific. Detailed bench and pilot studies would be required prior to implementing the technique.

10. Case Studies

Table 10-1. Case study using electrocoagulation

Hydro-Met LLC, Deadwood, SD

11. References

Adhoum, N., L. Monser, N. Bellakhar, and J.-E. Belgaied. 2004. "Treatment of Electroplating Wastewater Containing Cu^{2+} , Zn^{2+} , and Cr(VI) by Electrocoagulation," *Journal of Hazardous Materials* **B112**: 207–13.

Barkley, N. P., C. Farrell, and T. Williams. 1993. *Electro-Pure Alternating Current Electrocoagulation: Emerging Technology Summary*. EPA/540/S-93/504.

Basha, C. A., N. S. Bhadrinarayana, N. Anantharaman, and K. M. Meera Sheriffa Begum. 2007. "Heavy Metal Removal from Copper Smelting Effluent Using Electrochemical Cylindrical Flow Reactor," *Journal of Hazardous Materials* **152**: 71–78.

Heidmann, I., and W. Calmano. 2008. "Removal of Zn(II) , Cu(II) , Ni(II) , Ag(I) and Cr(VI) Present in Aqueous Solutions by Aluminum Electrocoagulation," *Journal of Hazardous Materials* **152**: 934–41.

Merzouk, B., B. Gourich, A. Sekki, K. Madani, and M. Chibane. 2008. "Removal Turbidity and Separation of Heavy Metals Using Electrocoagulation-Electroflotation Technique," *Journal of Hazardous Materials* **164**: 215–22.

Mollah, M. Y. A., R. Schennach, J. P. Parga, and D. L. Cocke. 2001. "Electrocoagulation (EC)—Science and Applications," *Journal of Hazardous Materials* **B84**: 29–41.

Mollah, M. Y. A., P. Morkovsky, J. A. G. Gomes, M. Kesmez, J. Parga, and D. L. Cocke. 2004. "Fundamentals, Present and Future Perspectives of Electrocoagulation," *Journal of Hazardous Materials* **B114**: 199–210.

Murugananthan, M., G. Bhaskar, G. Raju, and S. Prabhakar. 2004. "Removal of Sulfide, Sulfate and Sulfite Ions by Electro Coagulation," *Journal of Hazardous Materials* **B109**: 37–44.

Powell Water Systems, Inc. 2009. www.powellwater.com/.

Rodriguez, J., S. Stopić, G. Krause, and B. Friedrich. 2007. "Feasibility Assessment of Electrocoagulation Towards a New Sustainable Wastewater Treatment," *Environmental Science and Pollution Research* **14**(7): 477–82.

Willow Creek Reclamation Committee. 2006. *Nelson Tunnel Water Management Feasibility Study*.

Additional Resource: www.finishing.com/4800-4999/4924.shtml

◀ Back

▶ Visit ITRC Mining Waste Team Public Page

◀ Return to Title Page

▶ P

This Web site is owned by ITRC • www.itrcweb.org
50 F Street St., NW • Suite 350 • Washington, DC 20001 • P: 202-266-4920 • F: 202-266-4937 • Sponsored by Environmental
Council of the States

[Disclaimer, Privacy, and Usage Policies](#)

A Review to Determine State-of-The-Practice Treatment Technologies For Reducing Concentrations of Organotin Compounds in Wastewater

Messing, A. , L.M. Ramirez, and T. Fox, 1997

Executive Summary

The purpose of this study is to identify practical technology that can be used by shipyards to remove tributyltin (TBT) from large volumes of water to levels below 50 parts per trillion. This study is based on: (1) a review of scientific and engineering literature, (2) a review of U.S. Patents, and (3) a survey of manufacturers and users.

TBT based paints are the most popular antifouling paints used on the hulls of the global merchant fleet, and the market share of TBT is still growing despite its banning or partial banning in certain areas. Shipyards generate large volumes of TBT-laden washwater during normal drydock operations.

TBT has been found to be highly toxic in marine environments with observable environmental impacts at levels of parts per trillion. In 1997, after 10 years of study, The United States Environmental Protection Agency (U.S. EPA) proposed a national saltwater aquatic life criteria for TBT of 10 parts-per-trillion (62 CFR 42554, August 7, 1997). After the appropriate comment period, the standard chosen will become the basis for state water quality standards and water discharge permits throughout the U.S.

This study concludes:

1. There is no “off-the-shelf” technology directly applicable to shipyard waste streams that will reduce TBT levels in water below a concentration of 50 parts per trillion.
2. Because TBT is highly attracted to particulates in water, adsorption process may prove be the most effective means to reduce TBT concentration. It is suggested that technology such as Dissolved Air Flootation, and Activated Carbon adsorption are the best candidate technologies.
3. While there are accepted and practical water treatment technologies that may be effective in reducing TBT concentrations in waste streams, these technologies have not been applied to shipyard waste streams. It is recommended that practical trials be conducted as soon as possible.

Introduction

It is estimated that between 70% and 80% of the global merchant fleet has tributyltin (TBT) antifouling paint applied to their hulls. When these ships are dry-docked, shipyards can generate tens of thousands of gallons of TBT contaminated washwater. For twenty years a substantial global effort has been focused on qualifying the adverse ecological effects of TBT and other organotin compounds in aqueous environments, but very little work has been done to develop practical methods to remove TBT from wastewater streams. At this time U.S. shipyards have no practical guidance on any technology that can be employed to meet regulatory discharge limits. Responding to a written survey question about legislation limiting TBT concentrations in water or wastewater, Arcino Quiero Jr. of Newport News Shipbuilding states: “We are required by our VPDES [Virginia Pollution Discharge Elimination System] permit to submit to the DEQ [Department of Environmental Quality] quarterly progress reports and achieve compliance with final [discharge] limits, 50 ppt, within four years from the effective date of our permit, June 4, 2000.”[sic] This value is based on the current water quality criteria for TBT in Virginia waters. According to the Virginia Code (9VAC25-260-130) “[TBT] in freshwater shall not exceed 0.026 parts per billion (j.tg/l), and the concentration of tributyltin in saltwater shall not exceed 0.001 parts per billion (~.tg/l).”

Currently, the reduction of TBT concentrations has been accomplished by limiting or banning products that contain TBT (primarily anti-fouling paints). This control strategy of reducing TBT concentrations by limiting or banning TBT-containing products is a high priority in management guidelines suggested by international, federal and state agencies. The approach of reducing TBT concentrations by reducing the use of products containing this compound does not address the difficulties encountered by facilities that do not manufacture or use TBT-containing products, but come in contact with the substance from outside sources. There is very little published information concerning the treatment of TBT in wastewater.

The problem has become urgent. Two Virginia shipyards have water discharge permits that require compliance with Virginia's standard (50 ppt) within two years. Furthermore, US EPA in August, 1997, issued for comment a draft national standard. The Applied Marine Research Laboratory (AMRL) of Old Dominion University in conjunction with the Center for Advanced Ship Repair and Maintenance (CASRM) instituted a literature search to determine the state-of-the-art technological practices regarding the reduction of TBT concentrations in wastewater. The project has 3 components: (1) a search of scientific and engineering literature; (2) a search of patent literature; and (3) a survey of TBT users and manufacturers of the technology employed in industry. Manufacturers of TBT, industries that incorporate TBT into their products, state and federal regulatory agencies, and Regional Water Control Boards were also contacted by phone. Surveys were sent to shipyards, researchers, and industries to gain information concerning TBT disposal in waste streams. This report summarizes those findings.

After an extensive inquiry, several avenues of exploration that held promise did not yield the expected results. In particular, the Royal New Zealand Navy voluntarily implemented a waste water collection and treatment system of TBT for the effluent from the large dry-dock at the Devonport Base (de Mora, *et al.*, 1995). Inquiries to the naval attaché at the New Zealand Embassy in Washington, D.C., have not produced results in time for inclusion in this report. Also, the International Maritime Organization may be of help in finding suitable technology.

2

Legislative History

Tributyltin achieved notoriety during the early 1980s as a result of its use as an active biocide in antifouling paints. It was used as a substitute for organo mercury, arsenic or lead boosters in copper based paints or as the sole biocidal agent. It was once described as the most toxic substance ever deliberately introduced into the aquatic environment and caused damage by leaching from boat hulls and aquaculture cages into the water column (Goldberg, 1986). Particularly high concentrations occurred, therefore, in the vicinities of fish farms, harbors, marinas and other areas of high boat use.

The first evidence of the harmful effects of TBT come from Arcachon Bay on the west coast of France in the mid 1970's (Alziew, 1986). Oyster culture and pleasure boating are traditional activities there, and TBT contamination from boats was linked to high mortalities of oyster larvae and such severe malformations of the shells of adults that they were unmarketable.

Since that time, the adverse environmental effects of TBT have been studied extensively. A search of all TBT studies through 1995 found over 600 scientific papers.

As a result of all the attention, many countries have implemented a variety of laws controlling the release of organotin into the environment. Virtually all of the new regulations are directed toward the use of antifouling paint.

The first regulatory actions were adopted in France in 1982 when the government banned the application

of antifouling paints to hulls of most boats shorter than 25 meters (Abel, *et al.*, 1986)

Britain introduced regulations in 1985 controlling the TBT content and release rate in paints. A safe target goal of 20 µg/L was established. In 1987 this target was reduced to 2 µg/L (Vosser, 1987).

In the United States, the United States Environmental Protection Agency (US EPA) commenced a special review of TBT on antifouling in 1986. The Commonwealth of Virginia in 1987 enacted legislation similar to that already in place in Europe (Code of Virginia, Title 3.1). Maryland, California, Michigan and several other states followed suit. In 1988 the U.S. Congress passed the Organotin Act of 1988. It established interim restrictions on painting vessels shorter than 25m (except aluminum) and required paints to have a leach rate of no greater than 4.0 µg/cm²/day. It stated that the prohibition could remain in place until a final decision was issued by the administrator of the US EPA (U.S. Public Law, 1988)

In August 1997 the US EPA issued an "Ambient Water Quality Criteria Document for Tributyltin", for comment (US EPA, Federal Register). This document proposes a Final Chronic Value concentration of 0.01 µg/L and a Species Mean Acute Value of 0.61 µg/L.

Also, in 1997, the International Maritime Organization reviewed comments on a proposal to ban the application of TBT world wide. This ban to be effective 10 years after enactment. Action on this proposal is expected in 1998 (IMO, 1997).

3

CHAPTER 1 REVIEW OF PRIMARY MATERIAL

Literature Review

(Prepared by AISIRL)

Manufacturers of TBT, companies that incorporate TBT into their products, and researchers dispose of waste in one of four ways. Those companies and laboratories that use TBT in research quantities incinerate the hazardous waste components of the TBT waste stream in accordance with 40 CFR 260-263. This method destroys the organic component and renders the residue non-hazardous waste. Other companies transport their waste to US EPA permitted Treatment/Storage/Disposal facilities, also in compliance with 40 CFR 260-263. Many companies that incorporate TBT into their products (i.e., wood stains, paints) do not generate TBT containing hazardous waste. TBT is delivered in drums and is placed in holding vats. The only residual product associated with TBT is the drum in which it is delivered. The drums are triple rinsed in compliance with 40 CFR 260-263 and are, therefore, no longer subject to RCRA waste characterization. They are returned to manufacturer or are transported to a drum disposal unit. The rinseate is placed into the holding tank and incorporated into the product.

The major manufacturer of TBT in the United States, Elf-Atochem, recovers all waste generated. Solid and aqueous waste is transported to a tin recovery unit where it is incinerated at high temperatures to destroy any organic components. The resulting slag is sent to a smelting facility and is purified into tin ingots that are returned to the plant to be used in synthesizing more TBT. Another manufacturer located in Germany, Witco Corp., filters its waste and applies several separation processes. The resulting sludge is dried and placed in an approved landfill.

Numerous studies (Laughlin, *et al.*, 1986; Maguire and Tkacz, 1985; Randall and Weber, 1986) have demonstrated that TBT adsorbs to particulate material. This material can be organic or inorganic in nature. Monitoring conducted at a wastewater treatment plant in Zurich, Switzerland, indicated that a large portion of organotin species, including TBT, was removed after the primary clarifying treatment. Analysis indicated that 75% of the TBT was removed and had been transferred to the remaining sewage

sludge (Fent, 1996). Initial concentrations of TBT were between 64 and 217 ppt. Concentrations in the secondary effluent ranged from 7-47 ppt. After the secondary sedimentation treatment and aerobic treatment, 90% of the initial TBT concentration was removed from the wastewater. An additional filtration resulted in a 98% removal of the compound. Concentration ranges in the effluent were <1 .17 ppt. This plant is noted to be more efficient than most treatment facilities in Switzerland.

The Water Resources Division in the City of Livermore, California, monitors for TBT in their waste stream. They have a unique situation in that they are not near a coastal area and the TBT contamination originates from inland areas. Conclusions drawn by their personnel suggest that TBT is originating from water cooling towers, but this has not been confirmed. Procedures for treating wastewater at the Livermore facility start with the addition of iron (II) chloride to remove sulfides and to promote settling. Activated sludge is added and a secondary clarification step follows. Caustic in the form of sodium hydroxide is added to adjust the pH and then sodium hypochlorite is added as a disinfecting agent. Data seems to indicate that wastewater treatment protocols at this facility reduce TBT by 90% or more (Touray, personal communication). However, there is a considerable lag time between influent and effluent sampling and the residence time of the sewage was not stated. Therefore, the reduced concentration of TBT in the effluent may not directly correlate to the initial influent value.

4

If current wastewater technology proves useful in reducing TBT to acceptable levels by partitioning the compound to the solid phase, the resulting sludge may be a potential source of contamination. Sludge is often dumped at sea and it is also used as a fertilizer. If TBT is present in fertilizer, it may be transferred to soils. At sea, resuspension may occur and TBT may again become a contaminant to aquatic life (Page, 1996).

Sediment samples were collected near a shipyard located on the Fore River near South Portland, Maine, and analyzed for TBT (Page, 1996). Concentrations in the surface sediments ranged from 24-12,400 ng/g on a dry weight basis. Subsequent elutriate analysis determined that TBT was released into the water. The concentration was 0.14% of the total TBT in the sediment sample, suggesting that TBT is released slowly into the water. Even at a slow release rate, there is the potential for future contamination due to the fact that TBT contained in paint chips would be resistant to biodegradation and persist in the sediment. Also, deposit feeders could directly ingest TBT by feeding.

Degradation experiments have been conducted on sewage sludge under both aerobic and anaerobic conditions. (Fent, *et al.*, 1991). Calculated half lives of TBT in water using radio-labeled TBT are approximately 6-7 days (Seligman, *et al.*, 1988). The half life of TBT in the surface sediment is approximately 4-6 months (Stang, *et al.*, 1992). The degradation rates of TBT may be due to the high availability of nutrients in sewage sludge. The nutrients may be a preferred source of carbon for microbes as opposed to the carbon contained in TBT.

TBT degrades to dibutyltin (DBT) and monobutyltin (MBT) and eventually to tin ion. These compounds are less toxic to marine life than TBT. Fungal cultures and freshwater green alga demonstrate the ability to debutylate TBT to DBT and MBT. Diatoms and dinoflagellates also debutylate TBT. While degradation depends upon temperature and the presence of microorganisms, the microorganisms that biodegrade TBT may not be able to survive if the concentration of TBT is too high. Several papers describe microbial biofilms that accumulate TBT without subsequent degradation. No evidence has been found that these microbial methods have been used on a large scale for waste stream treatment.

5

A search of the U.S. Patent data base has been conducted to identify proprietary technology that can remove tributyltin or organotin, from aqueous streams to purity levels of <50 parts per trillion. The search found no turn-key technology that can accomplish this task.

The search was then widened to determine proprietary technology which can remove organic pollutants from aqueous streams to levels of parts per billion. This search produced a number of patents based on different technical approaches.

1. *Resin Beds*

A wide variety of cationic, anionic and non polar resins have been employed to purify water. Non-polar resins are effective for the removal of a wide range of organic pollutants.

- U.S. Patent 3,531,463 describes a process to remove phenols and chlorinated hydrocarbons contained in the effluent of a bleached Kraft pulp mill.

While the class of non-polar ion exchange resins have been found to absorb a wide range of organic pollutants, U.S. Patent 5,236,594 describes the benefits of using non-ionic polymeric resins, since these can be regenerated using solvents in which the pollutants are soluble. The preferred resins are products such as:

AMBERLIGHT® XAD	Rohm & Haas, Philadelphia, PA
Duolite ®	Chemical Process Co, Redwood, CA
Dialon ®	Mitsubishi Chemical Co, Tokyo, Japan

Water purity levels to 0.1 ppb (100 ppt) are claimed

U.S. Patent 3,853,758 describes the use of this type of resin to remove toxic organic pollutants from the effluent of a dye manufacturing plant. For best results contact times of 2-10 minutes are required. After treatment, pollutants can be extracted from the resin by mixing with solvents in ratio 1 volume of resin: 3 volumes solvent. Solvents can be methanol, acetone, dichloromethane, chloroform, diethyl ether and ethyl acetate.

2. *Activated Carbon*

Effluent treatment using activated carbon has been found to remove a wide range of organic pollutants from water. A search using key words “activated carbon” and “water purification” revealed in excess of 400 patents issued since 1973. Activated carbon is not selective and removes most organic compounds from water. It cannot be easily regenerated and spent carbon must be disposed by incineration or in an appropriate land fill.

U.S. Patent 5,399,263 describes a water purifier for supplying high purity water with a low organic carbon content. The purifier consists of a multibed purification cartridge having several layers of activated carbon and both cationic and anionic ion exchanger resins. It is claimed that water with a total organic carbon contents of up to 100 ppb (100,000 ppt) is produced.

6

U.S. Patent 4,007,116 describes a process for purification of wastewaters using activated carbon in a moving fluidized bed arrangement. Granular activated carbon is moved in through the bed in counterflow to the water stream, so as to continuously introduce fresh activated carbon particles at the top of the bed to compensate for using carbon withdrawn at the bottom. Organic carbon contents of 1 ppb (1000 ppt) are claimed.

Activated carbon can be manufactured in a number of different ways and in different forms. We have

identified 381 U.S. Patents issued since 1973 describing different processes of preparation, manufacture, and method of use for this product.

3. *UltravioletLight*

Ultraviolet light has been used to remove organic compounds, and in some cases microbes, from water. The mechanism for removal of organic pollutants is the partial breakdown of the organic molecule by UV and subsequent removal of the disassociation products by some other means.

U.S. Patent 5,302,356 discloses an ultrapure water treatment system comprising a 185 nm UV light source in conjunction with a catalytic filter made of a polymeric porous material with a photoactive catalytic coating. The UV light, catalyst and air act to convert organic contaminants to carbon dioxide.

U.S. Patent 5,061,374 describes a process where-by water is treated in a succession of water treatment steps comprising: mineral filter, mixed ion exchange resin bed, UV light source, a reverse osmosis stage and fine ultrafiltration stage. Final water purity is claimed to be 1 ppb (1,000 ppt).

4. *Ultrafiltration*

Many organic contaminants including TBT are attracted to particulates in water. The principle behind ultrafiltration systems is to remove the contaminants by removing the particulates from the water.

Several patents employ ultrafiltration as the final stage of a water purification sequence. U.S. Patents 5,376,281 and 5,302,356 both describe the use of ultrafiltration in conjunction with ultraviolet light.

5. *Bio!ogica!Degradation*

Many industrial effluent streams are treated successfullyby microbial degradation.

U.S. Patent 5,653,883 describes a method of removing organic contaminants from water by microbial degradation in a stirred tank system having a powdered or granular media for biofilm support.

Biodegradation will not take place if the pollutant concentration is so high as to poison the microbes. U.S. Patent 5,653,883.

7

Survey of Manufacturersand Users of TBT

Approximately 150 questionnaires were mailed to several research facilities and laboratories, a manufacturer of TBT, and industries that either incorporated TBT into their products or came in contact with TBT containing products. Sixteen questionnaires were returned. Researchers and laboratories comprise nine of the respondents and industries comprise the remaining seven (see Appendix D).

The only company that monitored for TBT is the manufacturer, Elf-Atochem. Generated waste is sent to a tin~recovery unit. All solid and aqueous waste is incinerated at high temperatures, which destroys the organic portion. The resulting slag is delivered to a smelting facility and the tin is recovered as purified ingots to be used in further TBT synthesis.

Companies that incorporate TBT into their products do not monitor for TBT because they do not generate a wastewater stream. Washdowns from TBT holding tanks and rinses from TBT drums are incorporated into the product. Mr. Algimantas Pliodzinskas, the Health and Safety Coordinator at Hempel Coatings (USA), Inc., a marine paint manufacturer, states that "any residue which cannot be utilized in their product is sent for disposal through fuel blending for cement kilns. All TBT containing paint products or raw materials are in a combustible form suitable for fuels blending."

None of the respondents from companies that incorporate TBT into their product were aware of any legislation in their respective regions that would regulate TBT discharge. Mr. Pliodzinskas stated that organotins are “by definition pesticides and are to be disposed of in accordance with federal, state and local regulations. RCRA regulations do not specifically list tin or TBTs as specific hazardous wastes.”

Most industries (primarily shipyards) that come in contact with products containing TBT are required to monitor for the compound. TBT monitoring is one of the requirements of the National Pollutant Discharge Elimination System (NPDES) permit. National Steel and Shipbuilding Company in San Diego, CA, currently monitors for TBT in the water column surrounding the facility, but not in its own discharge. A discharge of TBT can only occur at pier side at their establishment. Once their NPDES permit is renewed, however, TBT in the shipyard discharge will be monitored as well. This firm does not use any paints containing TBT unless a customer specifically requests it.

To reduce possible TBT contamination when applying 181-containing paints, Halter Marine Group, Inc. places plastic sheeting on the ground underneath the area to be painted. The plastic is moved from section to section to reduce the quantity of plastic used. This material is analyzed and disposed as a hazardous waste if necessary. Any sludges or solids such as paint suits, brushes, etc. are disposed in a similar fashion if found to be contaminated. When TBT-containing coatings are removed from vessels, the material is contained via “environmental screens” with a shade factor of 90% or more. These screens reduce off-site particulate migration. If the vessel is in dry-dock, “the screens and a temporary steel birm [sic] or wall of 12-18 inches is placed in areas to block any residual runoff.” (Appendix C) Norfolk Shipbuilding and Drydock Corporation (NORSHIPCO) has recently employed carbon-bed technology, but 181 concentrations in wastewater after treatment were 2 ppb; this concentration does not meet the proposed 50 ppt regulation. Still another facility manages its waste according to RCRA waste disposal guidelines.

A feasibility study was conducted by U.S. Filter for Newport News Shipbuilding with guidance from Rohm & Haas and the College of William and Mary Virginia Institute of Marine Sciences. A series of

8

resins was developed for the removal of copper in the effluent, but cost limitations did not allow further study to determine the efficiency of TBT removal.

There are several opinions concerning minimizing the hazards of TBT. One respondent wrote only that Best Management Practices need to be instituted. Suggestions from other respondents include entraining the wastewater and treating it, but details were omitted, and finding alternative sources of anti-foulants. It is understood that new anti-foulants might not be as effective as TBT, but the toxicity to the environment would be less. One shipyard representative stated that if a satisfactory solution for controlling TBT is determined, the rest of the world must adhere to these policies. If not, then contamination would persist despite the efforts to minimize the hazard TBT represents to aquatic life.

Research facilities that responded to the survey monitor for TBT at their respective laboratories or for clients, but do so for research purposes and not for compliance with any regulations. Each laboratory monitors in a slightly different fashion. Some laboratories directly sample and chemically analyze aqueous waste for clients or at their own facility. Others observe the emergence of imposex in biota as a biomarker for the presence of TBT in local coastal waters. Waste from these laboratories is quite small and is either incinerated or sent to a waste handling facility. Researchers have several suggestions for reducing TBT concentrations in water that range from containing initial waste and disposing of it at high temperatures, filtering contaminated water through an organic phase to which TBT will bind, or using biodegradation and biosorption techniques. NuTECH Enterprises, Inc., a waste disposal unit in Oceanside, California, has had success in reducing concentrations of other organometallic substances by using biodegradable quaternary surfactants. This company is willing to conduct experiments to determine

if this technology would be suitable for removal of TBT.

Most of the respondents do not know of any legislation enacted or pending that limits TBT concentrations in water. The exceptions are those respondents from Virginia and the United Kingdom (UK). The UK has an environmental quality standard of 2-3 ng/L in seawater - far more stringent than any standard in the U.S. at this time. Opinions on minimizing the hazard posed by TBT vary from banning the substance entirely, enforcing strict containment procedures by employing closed systems in dry docks, developing less toxic alternatives, to conducting a cost/benefit analysis of the use of TBT versus the impact of TBT on marine ecosystems.

9

CHAPTER 2 DISCUSSION (Prepared by CASRISI)

Discussion of Practical Alternatives for Removal of TBT from Water

There is no "off-the-shelf technology" that can be directly used by shipyards to achieve TBT discharge concentrations of <50 ppt.

Due to the very low volatility of TBT compounds, significantly lower than that of water, air stripping is not expected to be of value for removal of TBT from water.

Manufacturers of TBT use incineration to destroy TBT or recycle the TBT in waste streams into new product. These approaches are impractical in shipyards where TBT is dissolved in tens or hundreds of thousands of gallons of wash-water.

Reduction of aqueous TBT concentrations by sewage treatment has been demonstrated at a number of facilities around the world. Adsorption of TBT onto activated sewage sludge is significant. Typical results show influent TBT concentrations of >200 ppt and effluent concentrations of 50-100 ppt. However, one sewage facility in Zurich, which employed an extra treatment step, achieved an effluent concentration of 2 ppt (Fent, 1996). Shipyard effluents can contain >50,000 ppt TBT (Personal Communication with Tom Beacham from NORSHIPCO). This level is sufficiently toxic to suppress all microbial activity in activated sewage sludge (Muller, *et al.*, 1989).

Other technologies may be more directly applicable to shipyards than the technology used in water treatment facilities. The next section describes several approaches that may be more applicable to the removal of TBT from shipyard waste streams.

Technical Approaches Most Likely to Succeed

1. Dissolved Air Floatation (DAF)

TBT appears to be highly attracted to particulates in the water. Estimates of the water-solid coefficient range from 1,000 - 10,000 on a weight basis. For instance, Maguire *et al.* (1985) found a partition coefficient of 2180 ± 350 for TBT in water and sediment of Toronto harbor.

A Dissolved Air Floatation system can take advantage of this phenomenon to reduce TBT concentration in water by, perhaps, 1,000 times.

Control of pH may be important. Muller *et al.* (1989) showed solubility of TBT in water was minimum at a pH of 6.

Absorption processes may be able to reduce TBT concentrations to less than 50 ppt. In one sewage plant in Switzerland, TBT levels in water were reduced from 181 ppt to 9 ppt mainly by sedimentation in the primary classifier and subsequent treatment steps (Fent 1996).

**Quarterly Progress Report for
USEPA Grant S-82874601-1**

**Evaluate Pilot and Full-Scale Treatment Processes
to Remove TBT from Industrial Wastewater**

Submitted to:

Ruby Cooper
Project Officer
Water Permits Division
US Environmental Protection Agency
Ariel Rios Bldg
Washington, D.C. 20460

by

Gary C. Schafran
Civil and Environmental Engineering Department
Old Dominion University
Norfolk, VA 23529-0241

May 15, 2003

Summary of Recent Study Efforts

Research efforts in the most recent quarter were directed toward completion of the long-term study of tributyltin (TBT) removal with a laboratory granular activated carbon (GAC) column. This study was conducted over a nine-month period and for the last seven months of the study, was run on a continuous basis; during the first two months the column was run intermittently. At the conclusion of column operation, the GAC in the column was extruded and sectioned in 1.5 cm intervals. Portions of each section were extracted with methanol to determine the organotin content as a function of depth.

The influence of organic matter on the decomposition of TBT by UV photolysis was examined in a series of laboratory experiments since organic matter may interfere directly or through secondary reactions with the decomposition of TBT. Organic matter, measured as dissolved organic carbon (DOC), concentration, have been observed to vary in the final effluent of the full-scale treatment plant by approximately a factor of five and elevated DOC concentrations may inhibit TBT decomposition. The organic matter stock solution used in this study was generated by grinding and extracting organic matter from fouling organisms that were collected from a waterway in southeastern Virginia. This stock solution was generated and provided by Dr. Michael Unger from the Virginia Institute of Marine Science through a collaborative Sea Grant project.

Previous study efforts with the full-scale treatment plant revealed that particulate TBT was often the dominant fraction of TBT in the final effluent and that polymer was also present in the final effluent. A study to examine interactions between polymer and TBT was conducted in the most recent quarter to determine whether TBT complexes with or can be absorbed into polymer molecules. If this interaction occurs, it may enhance the transport of TBT through the GAC columns and into the final effluent of the full-scale treatment plant.

Proposals were received in response to the request for proposals¹ and reviewed by the study technical committee. A system consisting of three, 80-kW UV reactors proposed by Trojan Technologies, Inc. was selected and will be delivered this summer.

¹ Appendix 1, February 15, 2003 Progress Report for USEPA Grant S-82874601-1, Evaluate Pilot and Full-Scale Treatment Processes to Remove TBT from Industrial Wastewater.

Long-Term GAC Column Study of Tributyltin Removal

The long-term, laboratory GAC column study has been described in previous progress reports and the setup and operational conditions will be summarized here. The focus of the study was to generate a TBT breakthrough curve and develop an understanding of the adsorption capacity for the conditions under which the column was operated. The study began in July 2002 with influent solutions made up daily consisting of deionized-distilled water spiked with TBT-Cl and NaHCO₃ to achieve an influent pH value of approximately 7.0. During the study, influent conditions were changed at various points and these are summarized below (Table 1). Samples were collected at approximately daily intervals and subsequently analyzed for TBT and other organotin and inorganic tin concentrations. From the start until bed volume 1,500 the column was operated intermittently (10 to 12 hours per day, five days a week). The volume of water treated under this condition represents 7% of the total volume treated during this study. After bed volume 1,500 the column was run in a continuous flow mode and was interrupted only for a short duration each day while switching over to a new influent solution.

Table 1.
Long-term, Laboratory GAC Column Operational Conditions

Bed Volumes	Influent Composition	
0 to 3,293	TBT = 2×10^6 ng/L;	pH = 7.0
3,294 to 16,227	TBT = 8.2×10^5 ng/L;	pH = 7.0
16,228 to 17,303	TBT = 0 ng/L	pH = 7.0
17,304 to 18,276	TBT = 0 ng/L	pH = 8.5
18,277 to 19,266	TBT = 0 ng/L	pH = 5.5
19,267 to 22,630	TBT = 8.2×10^5 ng/L	pH = 7.0

Although TBT was the only tin species spiked into the influent water, dibutyltin (DBT), monobutyltin (MBT), and inorganic tin were all observed in the column effluent along with TBT (Figure 1; inorganic tin not shown). The low concentrations of DBT, MBT, and inorganic tin in the early stages of the study could have resulted from these constituents being present in the stock TBT solution that passed through the column. However, the concentration of all tin species rose dramatically over the course of the study indicating that the other tin species were by-products of TBT decomposition. This trend clearly indicates that TBT is not just removed by adsorption onto the carbon surface but that reactions occurring at the surface are causing its degradation. As noted in the February 2003 progress report, biological activity within the carbon may play an important role and may facilitate the decomposition of TBT.

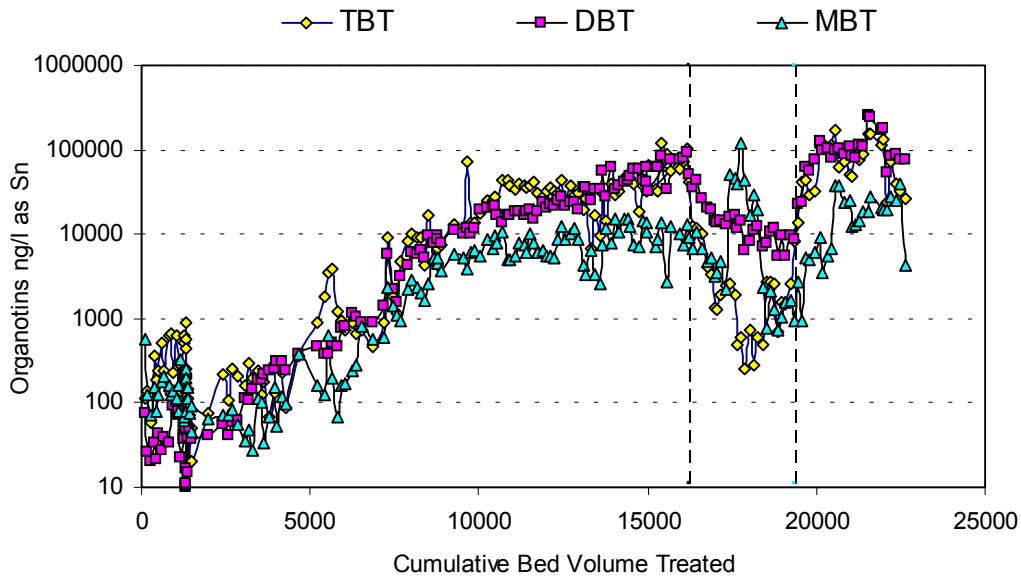

Figure 1. Organotin concentrations in the effluent of the long-term, laboratory GAC column study. Vertical lines indicate the beginning and ending of a period where influent waters were not spiked with TBT.

For a period of approximately 3,000 bed volumes (x days) the influent to the GAC column was prepared without the addition of tributyltin and at three different pH values, pH 7.0, 8.5, and 5.5, in succession (Table 1). During this period the effluent TBT concentrations were observed to decline as expected but it was clear that desorption/mobilization from the GAC column was occurring (Figures 2 and 3). Tributyltin concentrations were elevated throughout this period averaging (\pm s.d.) $5,350 \pm 4,590$ ng/L as Sn at pH 7, 933 ± 851 ng/L as Sn at pH 8.5, and $1,849 \pm 922$ ng/L as Sn at pH 8.55. Consequently, for a highly saturated column of GAC, when water of lower TBT concentration is passed through the column, it appears that desorption will occur to achieve equilibrium between the carbon surface and the aqueous phase.

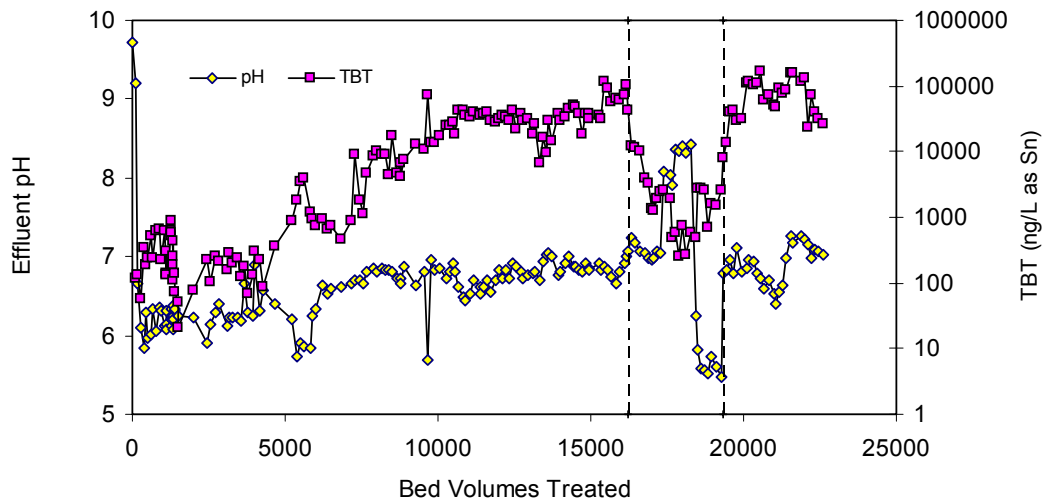

Figure 2. Effluent TBT concentrations and pH values for the long-term, laboratory GAC column study.

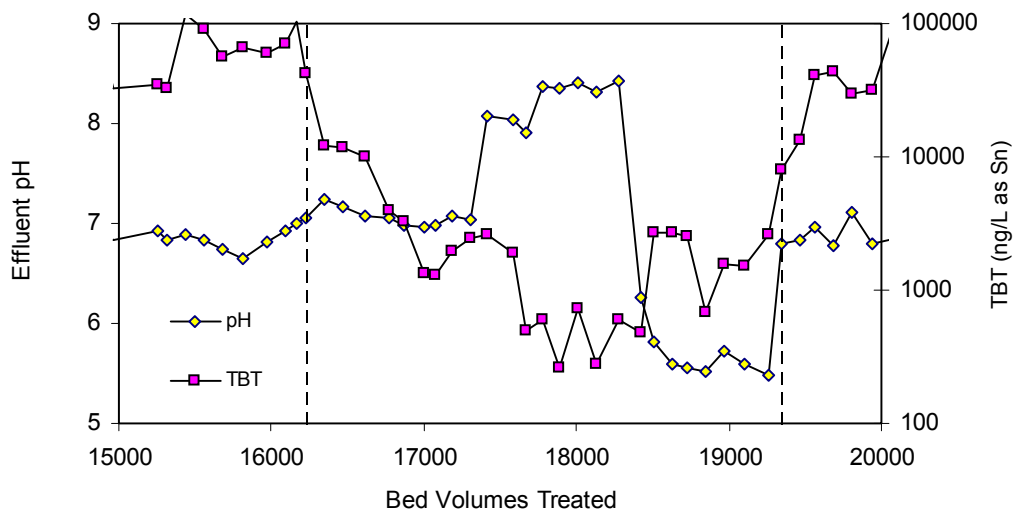

Figure 3. Effluent TBT concentrations and pH values for the period of zero TBT influent concentrations for the long-term, laboratory GAC column study. Effluent pH values correlate with influent pH values of 7, 8.5, and 5.5.

The influent pH variation portion of this study was conducted to determine to what extent the variation in pH of waters being passed through a GAC column might affect the mobility of TBT previously removed on granular activated carbon. During this period, the highest concentrations were observed at pH 7, immediately after beginning the zero TBT influent concentrations and the lowest concentrations were observed during the pH 8.5 influent phase. Based on adsorption isotherm data it was expected that at higher pH, elevated release of TBT might occur resulting in higher effluent TBT concentrations and that at pH 5.5, TBT release would be minimal due to greater affinity for the carbon surface. Higher TBT concentrations were observed at pH 5.5 indicating greater release of TBT from the carbon relative to pH 8.5. This observation contradicts previous adsorption isotherm observations that related greater adsorption at lower pH values. A similar trend was observed with DBT, however, MBT and inorganic tin were both elevated at higher pH values and were lower at pH 5.5 (Figure 4, MBT only). As noted previously, it appears that there is a microbial (bacteria) influence on the removal of TBT. It is possible that variations in the release of TBT that were observed in this effort may not only reflect equilibrium partitioning between the aqueous phase and the GAC surface but may also reflect uptake/release of TBT and possibly other tin species from bacteria. The potential role of bacteria as adsorbers of TBT is currently being evaluated.

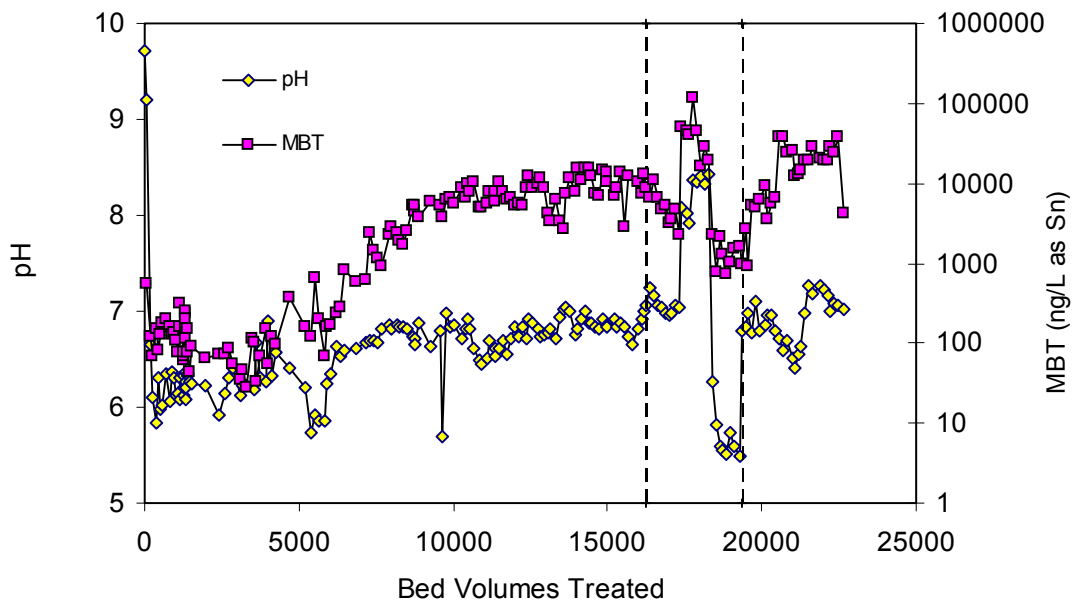

Figure 4. Effluent MBT concentrations and pH values for the long-term, laboratory GAC column study.

During the course of the column study, it became apparent that the organotin species in the effluent were changing in concentration and in relative amounts to each other (Figure 5 and 6, Table 2). Initially, the ratio of TBT to DBT was relatively high with an average ratio of 12.1 (n = 27). After switching to continuous column operation the ratio of TBT to DBT decreased (2.2 over the next 27 samples and 1.2 through the remainder of the study). This trend is consistent with development of an active population of microorganisms and increased conversion of TBT to DBT over time with lower adsorption of DBT relative to TBT. The ratio of DBT to MBT was also observed to change over the course of the study with the ratio of DBT to MBT increasing. DBT has been observed to be more favorably adsorbed to GAC than MBT (this study, unpublished data) so the increasing ratio would not be expected if DBT and MBT were present at similar concentrations before GAC adsorption. Based upon this trend, it would appear that biological activity or a GAC-surface mediated reaction preferentially degraded TBT to DBT at a rate that exceeded the conversion of DBT to MBT over the longer-term operation of the GAC column.

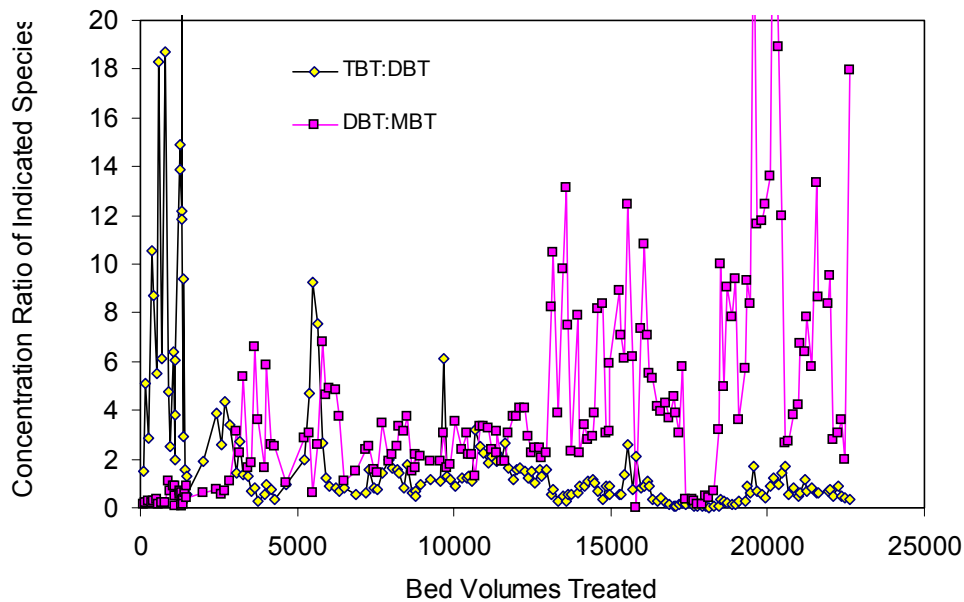

Figure 5. Effluent organotin ratios for the long-term, laboratory GAC column study. Concentration ratio is also equivalent to molar ratio due to species being represented on an “as Sn” basis.

Table 2.
Average Concentrations of Tin Species in the
Small-Scale GAC Column Effluent For Indicated Periods of
Bed Volumes

Bed Vol.	Average Concentration (ng/L)				
	TBT	DBT	MBT	Inorganic	Total
0-5K	266	94	129	383	871
5K-10K	7695	4799	2261	3900	18,655
10K-15K	31,319	29,850	8412	8872	78,453
15K-20K	22,217	30,945	12,851	19,125	85,138
20K-23K	88,279	115,792	19,548	9666	233,285
	Average Percentage				
0-5K	30%	11%	15%	44%	100%
5K-10K	41%	26%	12%	21%	100%
10K-15K	40%	38%	11%	11%	100%
15K-20K	26%	36%	15%	22%	100%
20K-23K	38%	50%	8%	4%	100%

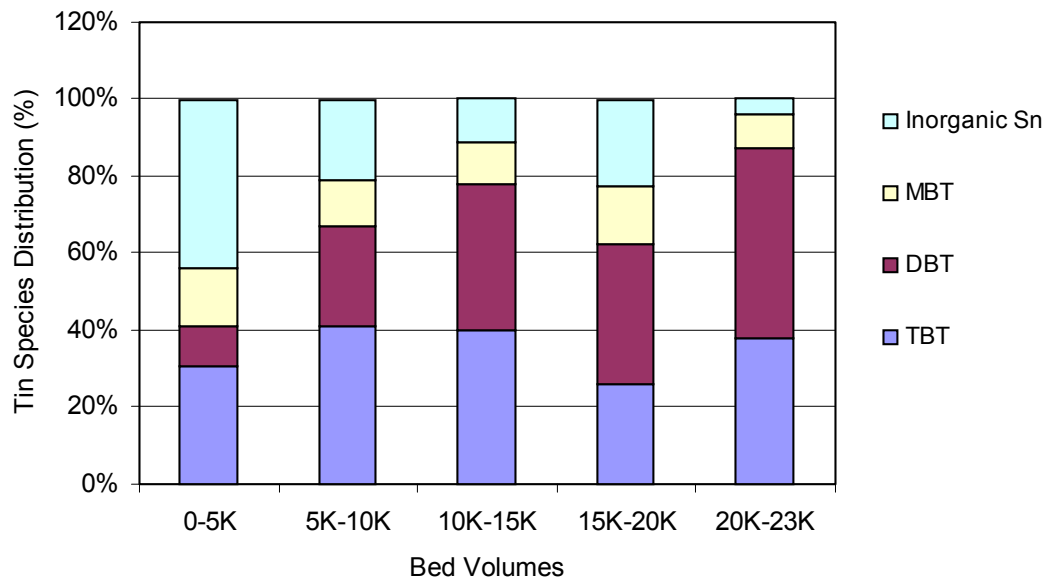

Figure 6. Distribution of effluent organotins as a function of period of column operation for the long-term, laboratory GAC column study.

The relationship between TBT and the byproducts of its decomposition are important to discern to better understand the processes occurring within a GAC column. Byproducts of TBT decomposition were examined in terms of the relationship with TBT to better understand how the GAC column affects TBT removal (Figure 7). The relationships were examined for three different periods: 0-16,227 Bed Volumes (BV), 16,228- 19,226 BV, 19,227 – 22,630 BV. These periods correspond to prior to, during, and following the period where no TBT was included in the influent. These periods are differentiated due to potentially different conditions affecting the relationships between the tin species.

Dibutyltin concentrations were positively correlated to TBT concentrations ($DBT = 1.08TBT + 788$; $r^2 = 0.76$; excludes the period during when influent TBT = 0 ng/L) suggesting similar influence on the mobility for each of these constituents (Figure 7a). Prior to the period when no TBT was in the influent the concentrations of the two species in the effluent were similar. When TBT was removed from the influent, TBT concentrations declined by a factor of over 300 while DBT concentrations declined by only a factor of 10. Since neither TBT nor DBT was present in the influent, this trend indicates preferential loss of DBT relative to TBT from the GAC surface that may be related to equilibrium partitioning. TBT has a higher affinity than DBT for GAC surface and if present at similar concentrations on the surface of the GAC it would be expected that in the absence of either constituent in the influent, that effluent concentrations of DBT would be higher than TBT. TBT and DBT concentrations both increased to similar and higher concentrations following reintroduction of TBT to the influent indicating that the period without TBT introduction did not dramatically influence subsequent adsorption.

Monobutyltin was positively correlated to TBT ($MBT = 0.15TBT + 2023$; $r^2 = 0.48$; excludes the period during when influent TBT = 0 ng/L) indicating that TBT concentrations were also influencing the formation and/or release of MBT from the GAC column (Figure 7b). During the period when TBT was not present in the influent MBT concentrations exhibited considerable scatter with a number of samples at concentrations elevated above the observed trend prior to and after the TBT-free influent. These elevated MBT concentrations reflected the pH influence previously described where MBT exhibited enhanced mobilization and/or formation at higher solution pH values.

Inorganic tin is generated by complete debutylation of TBT and consequently is without an organic moiety. Because of this condition, it might be expected that inorganic tin would behave differently to the organotins undergoing GAC adsorption. For the column study, inorganic tin was positively correlated to TBT but with greater scatter than observed with DBT and MBT (Figure 7c). As observed with MBT, inorganic tin concentrations were substantially increased in the column effluent during the pH 8.5 influent period. Comparing effluent inorganic tin concentrations versus pH for the entire period of the study revealed an apparent pH influence (Figure 8). The only data point inconsistent with a trend of increased solubility at higher pH, was the one at pH 9.2 which was the first effluent sample analyzed. A low inorganic tin concentration at this elevated pH value was likely due to the lack of tin retained on the column at this point.

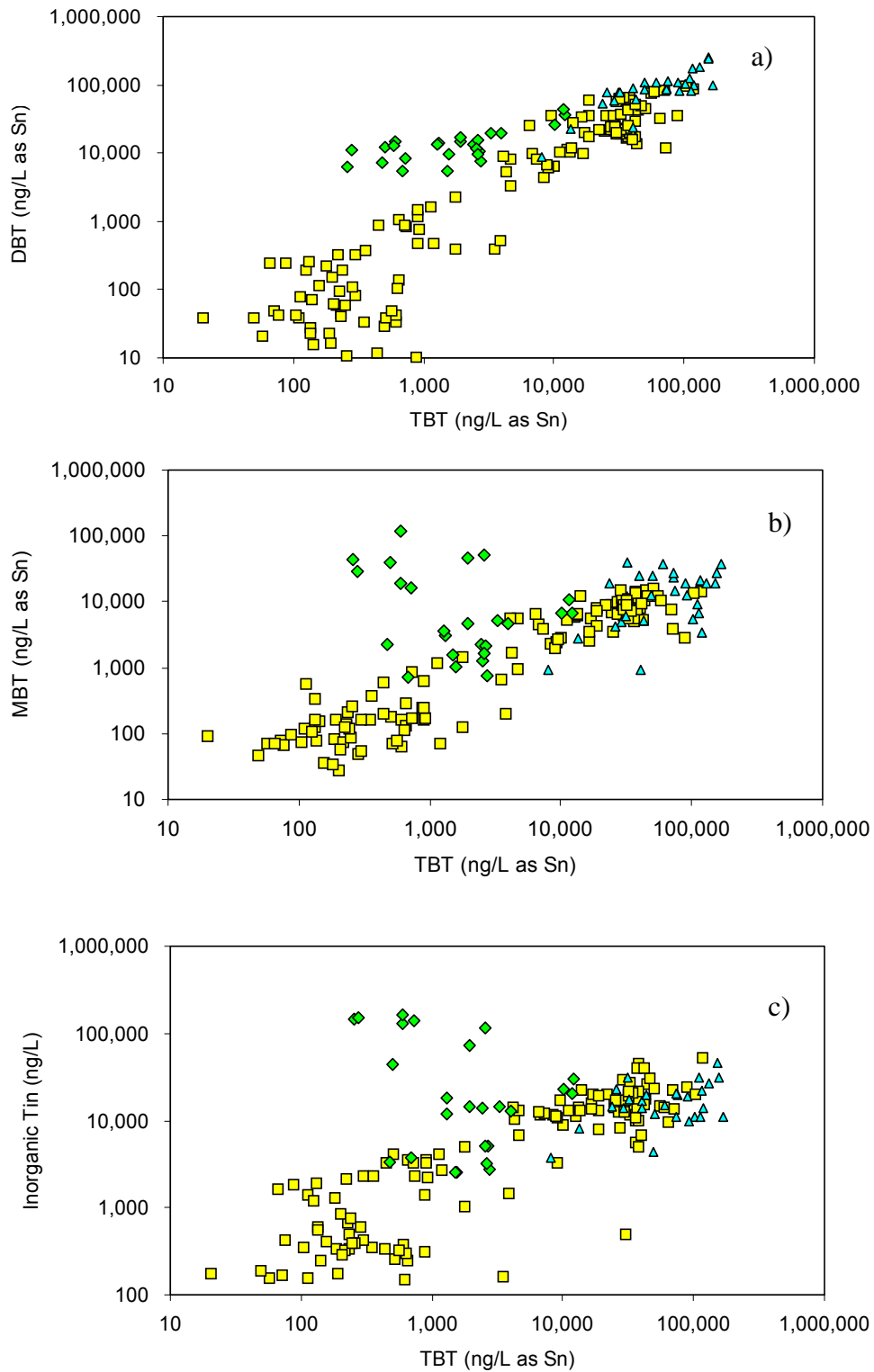

Figure 7. Relationships between TBT and TBT byproducts for the long-term, laboratory GAC column study. (■ 0-16,227 Bed Volumes, ◆ - 16,228- 19,226 BV, ▲ 19,227 – 22,630 BV)

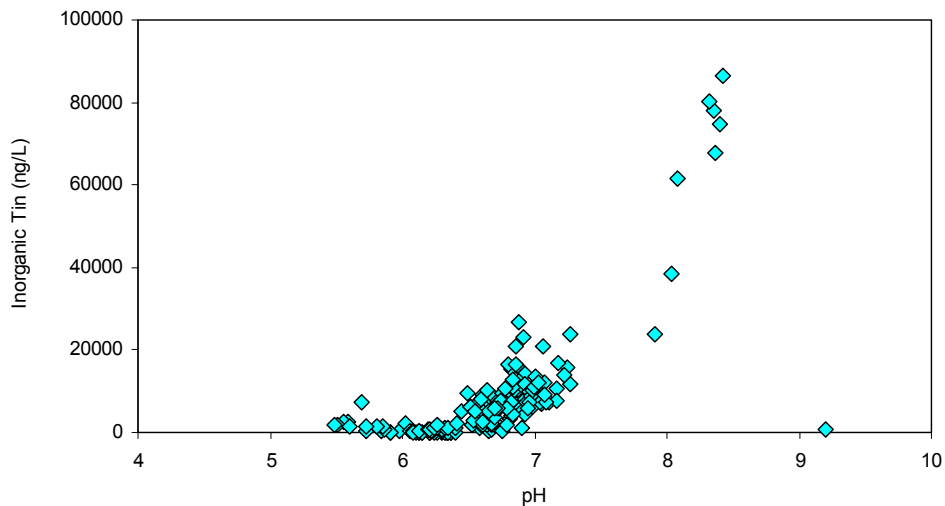

Figure 8. Effluent inorganic tin concentrations as a function of pH for the long-term, laboratory GAC column study. All data points included.

The relationship between the adsorption density (adsorbed TBT) and effluent TBT concentration is an important association to understand and was examined for this column study. Calculation of the apparent adsorption density was made by conducting a mass balance around the GAC column and assuming that any TBT or its byproducts not accounted for was adsorbed on the column. The mass of TBT retained on the column was calculated based on the following expression calculated each time a sample was retrieved (calculated on a tin basis):

$$\text{Apparent adsorbed TBT} = \text{TBT}_{\text{in}} - \text{TBT}_{\text{out}} - \text{DBT}_{\text{out}} - \text{MBT}_{\text{out}} - \text{Inorganic tin}_{\text{out}}$$

The expression is based on the assumption that any DBT, MBT, or inorganic tin observed in the effluent originates from TBT in the influent that was converted to these species while in the column.

The relationship between apparent adsorbed TBT and effluent TBT concentrations was observed to follow the trend of a typical adsorption isotherm with increasing effluent TBT concentrations at higher adsorbed TBT (Figure 9). Concentrations were generally below 2,000 ng TBT/L up to 50 mg TBT/g GAC while above this apparent adsorption density, effluent concentrations were observed to increase dramatically.

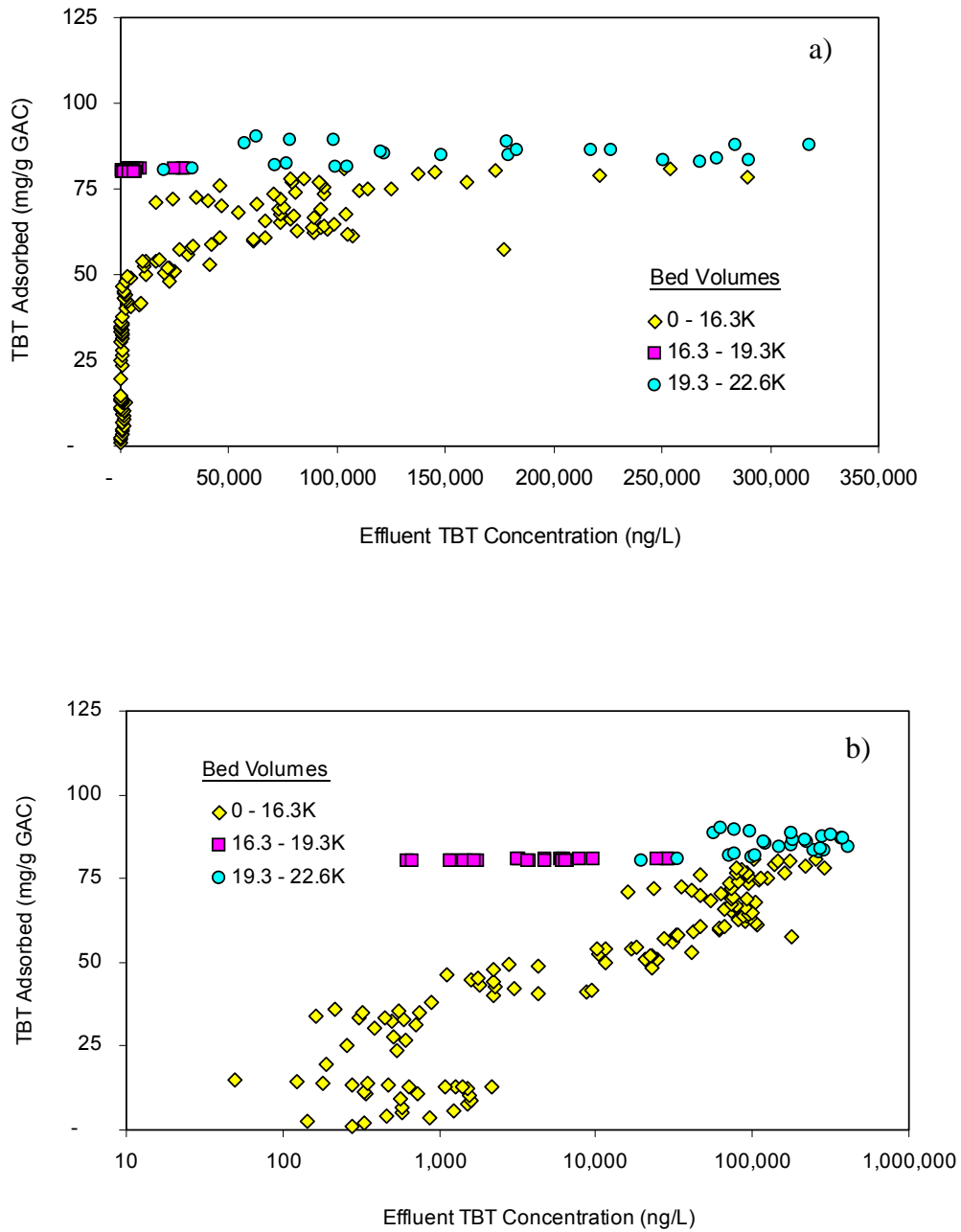

Figure 9. Relationship between effluent TBT concentrations and apparent adsorption density TBT (calculated). (◆ before, ■ during, and ● after the period of zero influent TBT concentration). Effluent concentration plots: (a) rectilinear, (b) \log_{10} .

The different periods previously identified in the long-term column study were plotted individually in Figure 9 to illustrate an apparent change that occurred to the relationship between the adsorbed and the effluent TBT concentrations. After the period when TBT was left out of the influent during which small amounts of TBT and other tin species were observed to be removed from the column (calculated reduction of 0.9 mg TBT/g GAC) the TBT concentrations were shifted lower (to the left in Figures 9a and 9b) relative to extrapolation of the trend observed prior to the period of no influent TBT. This may reflect some change to adsorbents on the carbon surface (decomposition?) that provided additional available surface when TBT was reintroduced to the influent.

Following the completion of the long-term, laboratory GAC column study, the GAC column was extruded intact and sectioned into six, 1.5-cm depth sections. A portion of each GAC section (average mass = 0.93 gram) was then extracted by placing the GAC in 250 mL of 99% methanol and placing on a shaking table for 24 hours. After 24 hours the GAC was allowed to settle and the solution was carefully poured off leaving the GAC behind. New methanol was then added and the procedure was repeated again. This procedure was conducted three times for each portion of GAC resulting in three samples (labeled 24, 48, and 72 hour) for TBT analysis. The tin species were measured in each solution and the results were used to calculate the amount of each tin species desorbed from the GAC column. Results illustrated that the majority of the tin species were removed from the carbon with the first extraction (24 hours) with successively smaller amounts with each additional extraction. The amount of TBT extracted for each section as a function of time illustrates the variation for all species (Figure 10).

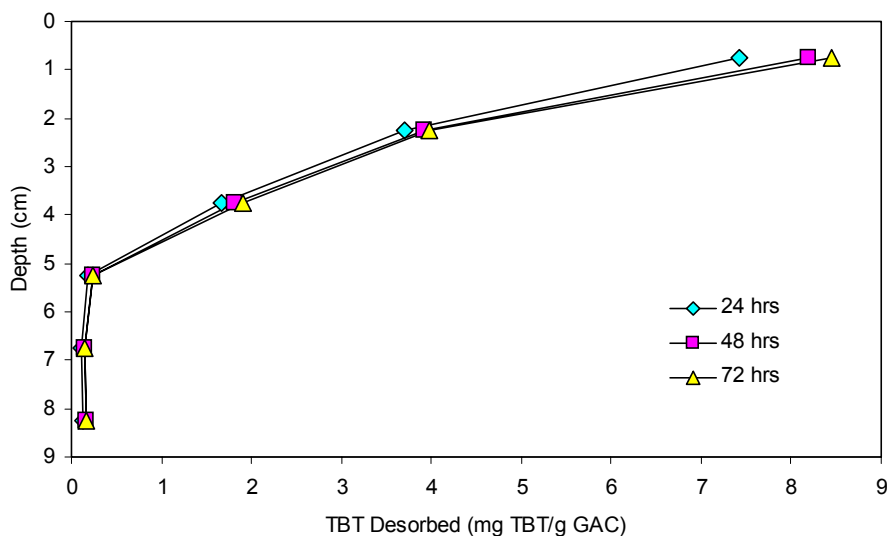

Figure 10. TBT desorbed by depth as a function of extraction time for the long-term, laboratory GAC column study. Depth is measured from the top of the GAC column first received the influent passing through the column. Times indicate extraction times.

Extraction of the GAC with methanol allowed characterization of the tin species that were retained (and extractable) on the GAC column as a function of depth. Surprisingly, tributyltin was one of the minor tin components on the GAC with MBT and DBT present on the GAC at greater concentrations than TBT (Figure 11). It is clear from the trend that the majority of removal occurred in the upper portion of the column with 80% of the tin species present in the top one-third of the column and 94% present in the top half. The distribution of tin species in the column is consistent with mass transfer expectations with elevated driving forces (transport from the bulk phase) and adsorption occurring at the point of highest concentration – at the top of the column. The low adsorption at the lower portion of the column is consistent with the observation that 85-95% TBT removal was still occurring at the end of the column study.

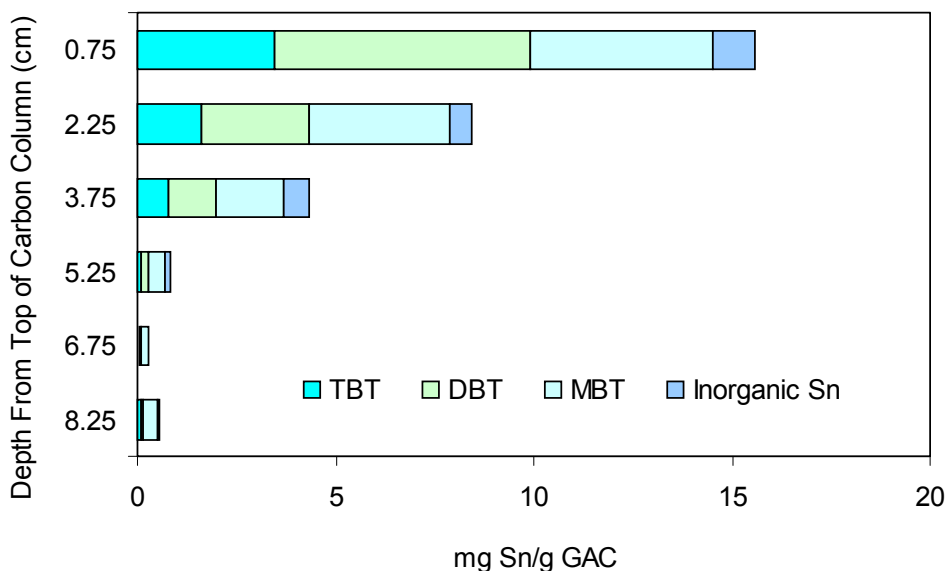

Figure 11. Distribution of organotin and inorganic tin concentrations as a function of depth for the long-term, laboratory GAC column study.

It is clear from the findings of the long-term laboratory GAC study that TBT was significantly converted to other tin species and that these tin species were both lost from the column and retained on the GAC surface. Unknown is the mechanism that is driving the conversion of TBT. GAC is capable of promoting the conversion of organic compounds abiotically through reaction with the GAC surface and this may explain the conversion, particularly in the early phase of the study. However, biological removal (adsorption) and conversion may also play an important factor, particularly as

performance was observed to significantly improve when conditions favoring microbial growth and activity (i.e. continuous flow) occurred. Studies are currently being conducted to evaluate the potential for microbial communities to provide additional adsorptive capacity.

Laboratory UV Studies

Laboratory studies examining UV-initiated decomposition of TBT have been conducted to better understand the influence of solution composition and better elucidate the mechanisms of TBT decomposition. Specific studies are described below.

Effect of DOC on TBT Removal by UV Treatment

Dissolved organic matter (measured as DOC) is present in all shipyard waters and at concentrations after treatment with GAC at levels between 1 and 5 mg/L. Since DOC may directly absorb UV light or react with oxidants formed during UV irradiation, it is important to understand what how DOC may affect the rate of TBT decomposition.

Removal of TBT was examined in batch mode using synthetic waters (DI spiked with TBT) and adjusted to five DOC concentrations. These values covered a range that would be expected at the end of the treatment process train currently being used. The influent water was prepared by adding 3.7 ml of TBT stock solution (1.022 mg/L TBT as Sn) and varying amount of DOC stock solution (357 mg C/L) in 3.79 L of DI water to get a concentration of 1000 ng/L TBT as Sn. The DOC stock solution was prepared at the Virginia Institute of Marine Sciences by grinding and extracting aquatic organisms that would be similar to those that might attach to ship hulls and then acidifying the solution to prevent biological deterioration. The pH of each prepared water was adjusted to 7 using 0.1N NaOH.

The results illustrate that DOC lowers the rate of removal of TBT but that the impact appears to be more substantial at low DOC concentrations and that at increasing DOC concentration the effect decreases (Figure 12). At zero DOC, the first-order rate constant for DOC was observed to be 0.23 min^{-1} while at DOC concentrations between 2.2 and 9.5 mg C/L the rate constant varied from 0.14 to 0.12 min^{-1} , respectively. The decrease in TBT degradation in the presence of DOC could be due to competitive absorption of light by DOC (i.e. DOC serves as a light filter). However, it would be expected that there would be a greater effect of increasing concentrations of DOC than observed here. Consequently, reduction in the rate of TBT decomposition may be through a secondary reaction where the available DOC was sufficient at low DOC to affect TBT decomposition by an alternate, indirect pathway while direct UV photolysis was primarily unaffected.

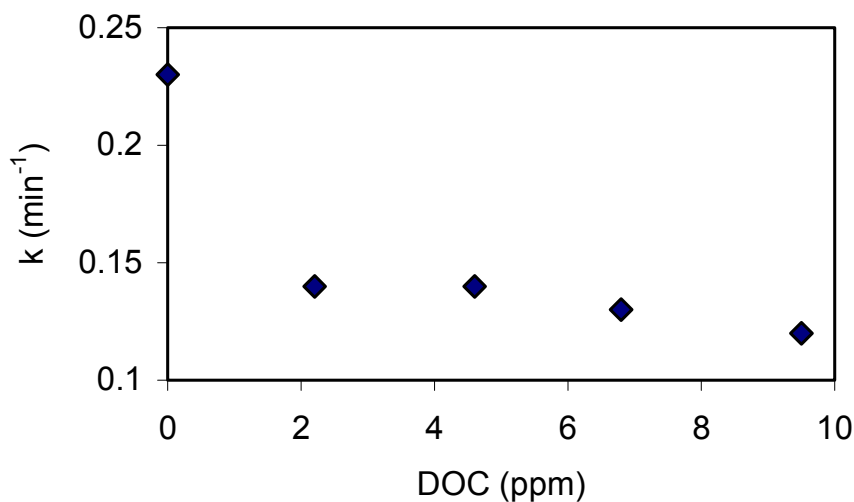

Figure 12. First-order rate constants for TBT decomposition as a function of DOC concentration in solution.

Effect of DOC on the Photodecomposition of Hydrogen Peroxide

Hydrogen peroxide has been observed to increase the rate at which TBT is decomposed and it is planned for use in the full-scale system to be acquired. DOC is known to affect the UV decomposition of H_2O_2 by absorbing UV light as well as by acting as a scavenger of hydroxyl radical which is produced by the decomposition of hydrogen peroxide. In this manner, DOC can influence the chain reaction of hydrogen peroxide decomposition and potentially conversion of TBT. The effect of DOC on the photodecomposition of H_2O_2 was investigated with the laboratory reactor as described above.

The DOC source was the same as noted above (VIMS) and three different DOC concentrations were investigated, 2.5, 5 and 10 mg C/L. Solutions were spiked with 50 mg/L of H_2O_2 and irradiated for the desired period of time. At the end of the desired irradiation period, the lamps were turned off and the sample was immediately analyzed for H_2O_2 concentration. The results illustrate an effect of DOC on the decomposition of H_2O_2 that is similar to that observed for the decomposition of TBT. The rate of decomposition was affected most significantly between 0 and 2.2 mg C/L of DOC and much less above this DOC concentration (Figures 13 and 14). The similarity of the effect of DOC on the decomposition of these constituents suggests that the mechanism by which DOC interferes with their decomposition is similar.

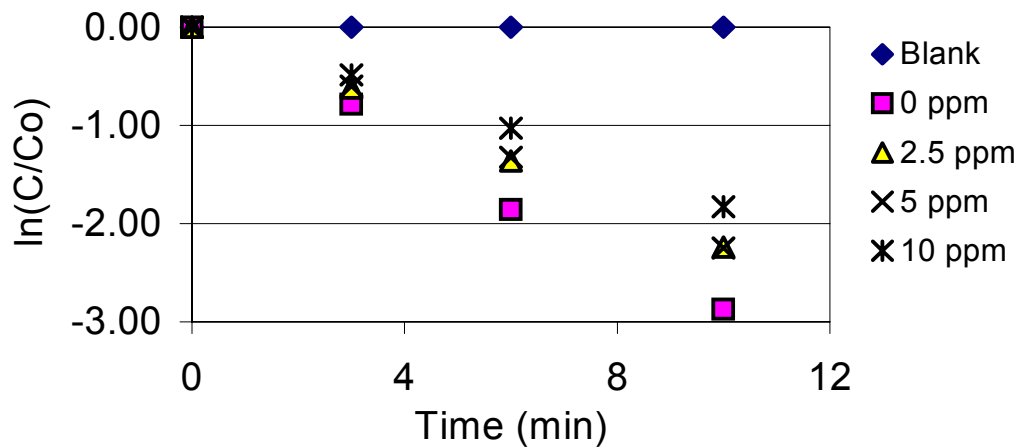

Figure 13. Natural log of the ratio of hydrogen peroxide remaining at each irradiation time and DOC concentration. Note that blank was as 0 mg C/L DOC solution placed in the UV reaction vessel but the lamps were not turned on.

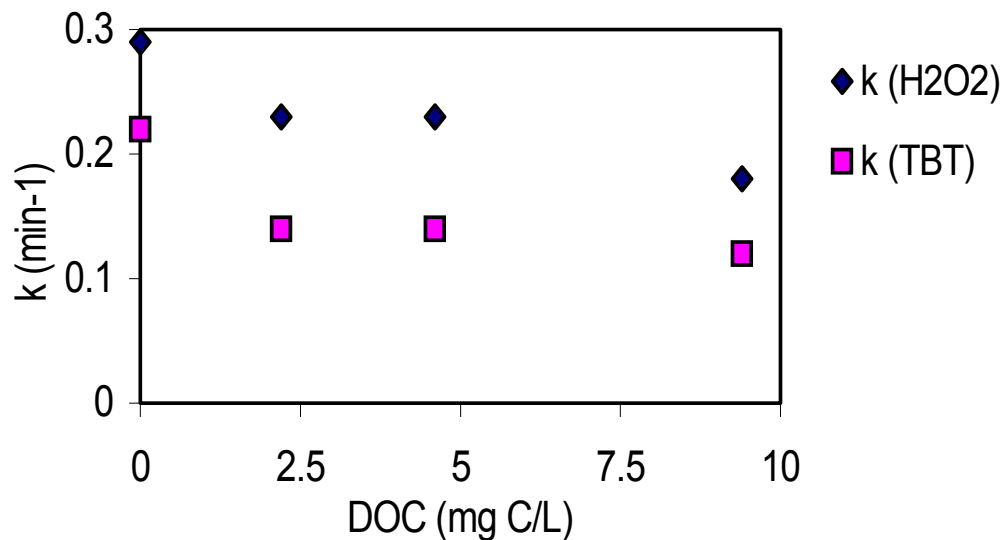

Figure 14. Rate constants for H₂O₂ and TBT decomposition by UV photolysis as a function of solution DOC concentration.

TBT Interactions With Coagulant Aids

Previous study efforts with the full-scale treatment plant revealed that particulate TBT was often the dominant fraction of TBT in the final effluent and that polymer was also present in the final effluent. A study to examine interactions between polymer and TBT was conducted to determine whether TBT complexes with or can be absorbed into polymer molecules. In this experiment, deionized-distilled water was spiked with tributyltin chloride to a concentration of 2,440 ng TBT/L and then separated into six 1-liter aliquots to which a 1 mg/L polymer dose was applied to each. Cationic, anionic, and nonionic polymers were all examined as well as a control (no polymer). Following a period of mixing, an aliquot of each solution was filtered through a 0.1 μm filter and then TBT analyses were conducted on the filtered and unfiltered samples for each solution. Previous work with polymers had exhibited that large, organic polymers could be retained on a 0.1 μm filter. Hence, if TBT was associating with the polymers, it was expected that the TBT would be captured on the filters and measured at much lower concentration in the filtrate.

TBT concentrations in the majority of the unfiltered solutions were relatively close to the initial concentration suggesting that the borohydride-TBT analytical method was capable of measuring TBT in the presence of the polymers (Figure 15). The one exception was the Selfloc-2250, an anionic polymer that was measured at 23% below the initial TBT concentration. The filtered sample TBT concentrations were all significantly lower in the polymer containing samples, particularly the cationic and anionic solutions. This result indicates that TBT does associate with the polymers and that if polymers carry through a treatment system, which we have previously observed that they do, then they may be capable transporting associated (complexed, absorbed, or adsorbed?) TBT.

An interesting finding was made in preparing to conduct the polymer study. Each polymer was added to DI water and measured for TBT prior to the experiments to prove that they were TBT free (this was expected). However, TBT was measured in one polymer (Magnifloc E30) at a concentration of 123 ng/mg polymer. The presence of TBT was confirmed when replicate solutions were made.

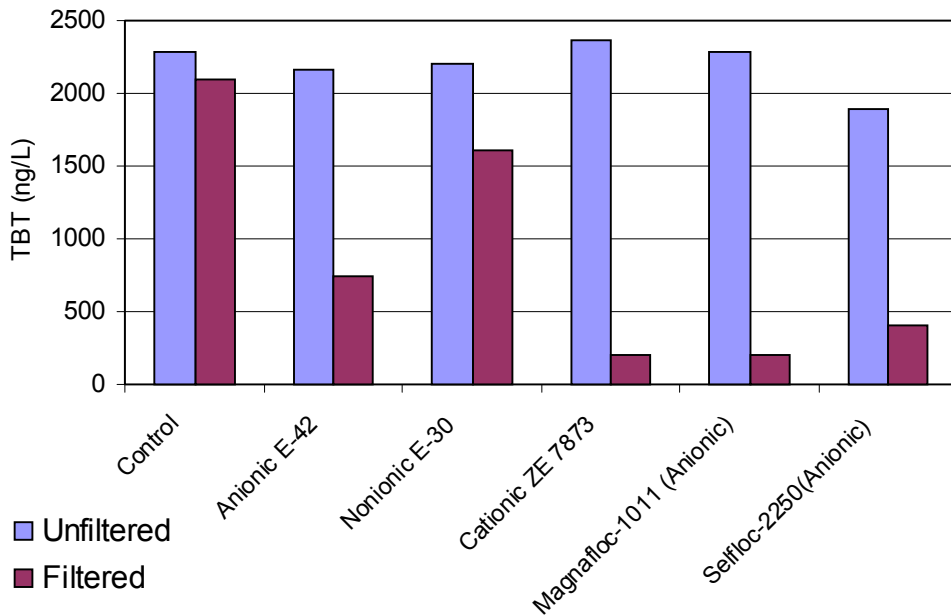

Figure 15. Filtered and unfiltered TBT concentrations measured in the indicated polymer solutions. Polymer concentration was 1 mg/L as product. Control contained no polymer.

Acquisition of a Full-Scale Ultraviolet Treatment System

Proposals were received in response to the request for proposals² and reviewed by the study technical committee. A system consisting of three, 80-kW UV reactors proposed by Trojan Technologies, Inc. was selected and will be delivered in early August.

Future Efforts

The delivery of the full-scale treatment plant will occur in August and will be integrated with the CASRM treatment plant and subsequently performance tested. The influence of the operational condition of the CASRM treatment plant in front of the UV system and its impact on the UV system will be examined in detail.

² Appendix 1, February 15, 2003 Progress Report for USEPA Grant S-82874601-1, Evaluate Pilot and Full-Scale Treatment Processes to Remove TBT from Industrial Wastewater.

Additional UV experiments are being conducted to characterize the DBT and MBT rates of decomposition so that an overall model of organotin decomposition by UV photolysis can be developed. A number of continuous flow GAC column experiments have been conducted with TBT-containing shipyard waters. TBT, copper, and zinc removal have been examined and efforts have recently been completed on the studying the effect of backwashing on the remobilization of these metals. The influence of sudden changes in pH on metal remobilization from the columns has also been studied.

Acknowledgments

Research results presented in this report have been due to the efforts of Old Dominion University research assistants Ram Prasad, Prem Bhandari, Khalid Qadwai, Shilpa Shivakumar, and Steven Roelands. In addition, TBT (and other butyltins) analyses and identification of other tin compounds in some of the long-term GAC column study samples have been conducted at the Virginia Institute of Marine Sciences under the direction of Dr. Michael Unger. The DOC used in the UV experiments was also developed in Dr. Unger's laboratory.

Operational management of the CASRM full-scale treatment plant has been coordinated by John Soles, Frank Thorn, and Chris Walter of Northrop-Grumman Newport News Shipbuilding (NG-NNS) and Mike Ewing of Norshipco and Frank Wheatley of Colonna's Shipyard.

Search Options

- [Advanced Search](#)
- [Search Help](#)

Search Menu

Sign up / Log in

- [Sign up / Log in Institutional / Athens login](#)

English

- [Deutsch](#)

Academic edition

- [Corporate edition](#)

Skip to: [Main content](#) [Side column](#)

- [Home](#)
- [Contact Us](#)

[Look Inside](#) [Get Access](#)

Find out how to access preview-only content

[Water, Air, & Soil Pollution](#)

January 2013, 224:1400

Removal Processes for Tributyltin During Municipal Wastewater Treatment

- [M. D. Scrimshaw,](#)
- [D. Hala,](#)
- [A. E. Okiemute,](#)
- [E. Cartmell,](#)
- [J. N. Lester](#)
- ... show all 5 hide

Buy now

Rent the article at a discount

[Rent now](#)

* Final gross prices may vary according to local VAT.

[Get Access](#)

Abstract

The fate and behaviour of tributyltin (TBT) at two wastewater treatment works was examined. Both sites had two inlet streams, and each utilised high rate biological filters (biofilters) on one the streams, before treatment of the combined flows on trickling filters, with one having additional tertiary processes, installed to remove ammonia and solids. The study was designed to determine if these processes enhanced the removal of TBT. Degradation of TBT was observed in one of the biofilters, possibly as a result of temperature and hydraulic loading. At the treatment works with tertiary processes, the mass flux showed the overall removal of TBT was 68 %, predominantly due to removal with solids in the primary settlement processes. However, overall removal of 95 % was observed in the conventional trickling filter works with 94 % of this due to biodegradation in the trickling filter. The two works both removed TBT, but at different treatment stages and by different processes. Differences in the form (solubility) of TBT in the influent may have attributed to this, although further understanding of factors controlling degradation would allow for a more complete assessment of the potential of biological processes to remove hazardous compounds from wastewaters.

Page %P

[Close Plain text](#)

Removal Processes for Tributyltin During Municipal Wastewater Treatment

M. D. Scrimshaw · D. Hahn · A. E. (Kierste) Carmel · A. N. Lester

Received: 24 May 2013 / Accepted: 14 November 2013
© Springer Science+Business Media Dordrecht 2013

Abstract The fate and behaviour of tributyltin (TBT) at two wastewater treatment works was examined. Both sites had two inlet streams, and each utilised high rate biological filters (biofilters) on one the streams, before treatment of the combined flows on trickling filters, with one having additional tertiary processes, installed to remove ammonia and solids. The study was designed to determine if these processes enhanced the removal of TBT. Degradation of TBT was observed in one of the biofilters, possibly as a result of temperature and hydraulic loading. At the treatment works with tertiary processes, the mass flux showed the overall removal of TBT was 68 %, predominantly due to removal with solids in the primary settlement processes. However, overall removal of 95 % was observed in the conventional trickling filter works with 94 % of this due to biodegradation in the trickling filter. The two works both removed TBT, but at different treatment stages and by different processes. Differences in the form (solubility) of TBT in the influent may have attributed to this, although further understanding of factors controlling

degradation would allow for a more complete assessment of the potential of biological processes to remove hazardous compounds from wastewaters.

Keywords Trickling filter · Tributyltin · Aeration · Biodegradation · Wastewater

1 Introduction

The fate, behaviour and environmental impact of tributyltin (TBT) in the aquatic environment as the result of its use as an antifouling on the hulls of boats and ships is well understood (Clark et al. 1989; Dawson et al. 1993a). Restrictions on the use of TBT as an antifouling, including a total ban in the UK on the sale of TBT containing antifouling paints for use on vessels <10 m, brought about a dramatic reduction in its presence in estuarine and coastal waters (Dawson et al. 1993a, c, 1994). With this there was a concomitant reduction in its endocrine-disrupting impact in particular for molluscs including the economically important oyster (Dawson et al. 1993). Although endocrine disruption in the environment had been recognised since the 1970s (Dobbs et al. 1970), the environmental damage caused by TBT's use as a ship antifouling brought this problem to the attention of a wide audience (Hites et al. 1989).

While the cessation of the use of TBT as an antifouling on small vessels brought about dramatic reductions in the concentrations of TBT detected in inland and

M. D. Scrimshaw (✉) · D. Hahn · A. E. (Kierste) Carmel
Institute for the Environment, Brunel University,
Uxbridge, Ux8 3PH, UK
e-mail: m.d.scrimshaw@brunel.ac.uk

A. N. Lester
Camford Water Science Institute,
School of Applied Sciences, Brunel University,
Buckingham MK6 4PU, UK

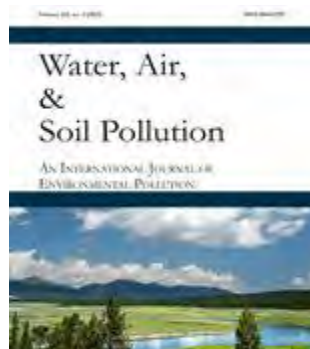

Within this Article

1. Introduction
2. Materials and Methods
3. Results
4. Discussion
5. Conclusions
6. References
7. References

Other actions

- [Export citation](#)
- [Register for Journal Updates](#)
- [About This Journal](#)
- [Reprints and Permissions](#)
- [Add to Papers](#)

Share

[Share this content on Facebook](#) [Share this content on Twitter](#) [Share this content on LinkedIn](#)

Related Content



Supplementary Material (0)

References (28)

1. Alzieu, C., Sanjuan, J., Michel, P., Borel, M., & Dreno, J. P. (1989). Monitoring and assessment of butyltins in Atlantic coastal waters. *Marine Pollution Bulletin*, 20, 22–26. [CrossRef](#)
2. Bacon-Montigny, C., Lespes, G., & Potin-Gautier, M. (2000). Improved routine speciation of organotin compounds in environmental samples by pulsed flame photometric detection. *Journal of Chromatography. A*, 896, 149–158. [CrossRef](#)
3. Bedding, N. D., McIntyre, A. E., Perry, R., & Lester, J. N. (1982). Organic contaminants in the aquatic environment. I. Sources and occurrence. *Science of the Total Environment*, 25, 143–167. [CrossRef](#)

4. Berg, M., Arnold, C. G., Muller, S. R., Muhlemann, J., & Schwarzenbach, R. P. (2001). Sorption and desorption behavior of organotin compounds in sediment–pore water systems. *Environmental Science and Technology*, 35, 3151–3157. [CrossRef](#)
5. Chau, Y. K., Zhang, S., & Maguire, J. (1992). Occurrence of butyltin species in sewage and sludge in Canada. *Science of the Total Environment*, 121, 271–281. [CrossRef](#)
6. Clark, E. A., Sterritt, R. M., & Lester, J. N. (1988). The fate of tributyltin in the aquatic environment: an overview. *Environmental Science and Technology*, 22, 600–604. [CrossRef](#)
7. Dodds, E. C., Goldberg, L., Lawson, W., & Robinson, R. (1938). Oestrogenic activity of certain synthetic compounds. *Nature*, 141, 247. [CrossRef](#)
8. Donard, O. F. X., Quevauviller, P., & Bruchet, A. (1993). Tin and organotin speciation during wastewater and sludge treatment process. *Water Research*, 27, 1085–1089. [CrossRef](#)
9. Dowson, P. H., Bubb, J. M., & Lester, J. N. (1993a). A study of the partitioning and sorptive behaviour of butyltins in the aquatic environment. *Applied Organometallic Chemistry*, 7, 623–633. [CrossRef](#)
10. Dowson, P. H., Bubb, J. M., & Lester, J. N. (1993b). Temporal distribution of organotins in the aquatic environment five years after the 1987 UK retail ban on TBT based antifouling paints. *Marine Pollution Bulletin*, 26, 487–494. [CrossRef](#)
11. Dowson, P. H., Bubb, J. M., Williams, T. P., & Lester, J. N. (1993c). Degradation of tributyltin in freshwater and estuarine marine sediments. *Water Science and Technology*, 28, 133–137.
12. Dowson, P. H., Bubb, J. M., & Lester, J. N. (1994). The effectiveness of the 1987 retail ban on TBT based antifouling paints in reducing butyltin concentrations in East Anglia, UK. *Chemosphere*, 28, 905–910. [CrossRef](#)
13. Fent, K., & Muller, M. D. (1991). Occurrence of organotins in municipal wastewater and sewage sludge and behaviour in a treatment plant. *Environmental Science and Technology*, 25, 489–493. [CrossRef](#)
14. Graham, D. W., & Curtis, T. P. (2003). Ecological theory and bioremediation. In I. M. Head, I. Singleton, & M. G. Milner (Eds.), *Bioremediation—a critical review*. Norwich: Horizon Scientific.
15. Hoch, M. (2001). Organotin compounds in the environment—an overview. *Applied Geochemistry*, 16, 719–743. [CrossRef](#)
16. Jones, O. A. H., Green, P., Voulvoulis, N., & Lester, J. N. (2007a). Questioning the excessive use of advanced treatment to remove organic micropollutants from wastewater. *Environmental Science and Technology*, 41, 5085–5089. [CrossRef](#)
17. Jones, O. A. H., Voulvoulis, N., & Lester, J. N. (2007b). The occurrence and removal of selected pharmaceutical compounds in an English sewage treatment works utilizing activated sludge treatment. *Environmental Pollution*, 145, 738–744. [CrossRef](#)
18. Kawai, S., Kurokawa, Y., Harino, H., & Fukushima, M. (1998). Degradation of tributyltin by a bacterial strain isolated from polluted river water. *Environmental Pollution*, 102, 259–263. [CrossRef](#)
19. Landmeyer, J. E., Tanner, T. L., & Watt, B. E. (2004). Biotransformation of tributyltin to tin freshwater river-bed sediments contaminated by an organotin release. *Environmental Science and Technology*, 38, 4106–4112. [CrossRef](#)

20. Maguire, R. J. (1987). Review: environmental aspects of tributyltin. *Applied Organometallic Chemistry*, 1, 475–498. [CrossRef](#)
21. McAdam, E., Bagnall, J., Soares, A., Koh, Y. K. K., Chiu, T. Y., Scrimshaw, M. D., Lester, J., & Cartmell, E. (2011). Fate of alkylphenolic compounds during activated sludge treatment: impact of loading and organic composition. *Environmental Science and Technology*, 45, 248–254. [CrossRef](#)
22. Plagellat, C., Kupper, T., de Alencastro, L. F., Grandjean, D., & Tarradellas, J. (2004). Biocides in sewage sludge: quantitative determination in some Swiss wastewater treatment plants. *Bulletin of Environmental Contamination and Toxicology*, 73, 794–801. [CrossRef](#)
23. Sarradin, P.-M., Lapaquillerie, Y., Astruc, A., Latouche, C., & Astruc, M. (1995). Long term behaviour and degradation kinetics of tributyltin in a marine sediment. *Science of the Total Environment*, 170, 59–70. [CrossRef](#)
24. Seligman, P. F., Valkirs, A. O., & Lee, R. F. (1986). Degradation of tributyltin in San Diego Bay, California, waters. *Environmental Science and Technology*, 20, 1229–1235. [CrossRef](#)
25. Seligman, P. F., Grouhoud, J. G., Valkirs, A. D., Stang, P. M., Fransham, R., Stallard, M. O., Davidson, B., & Lee, R. F. (1989). Distribution and fate of Tributyltin in the United States marine environment. *Applied Organometallic Chemistry*, 3, 31–47. [CrossRef](#)
26. Stasinakis, A. S., Thomaidis, N. S., Nikolaou, A., & Kantifes, A. (2005). Aerobic biodegradation of organotin compounds in activated sludge batch reactors. *Environmental Pollution*, 134, 431–438. [CrossRef](#)
27. Vossler, T. L., & Maclas, E. (1986). Contribution of fine particle sulfates to light scattering in St. Louis summer aerosol. *Environmental Science and Technology*, 20, 1235–1243. [CrossRef](#)
28. Voulvoulis, N., Scrimshaw, M. D., & Lester, J. N. (2004). Removal of organotins during sewage treatment: a case study. *Environmental Technology*, 25, 733–740. [CrossRef](#)

About this Article

Title

Removal Processes for Tributyltin During Municipal Wastewater Treatment

Journal

[Water, Air, & Soil Pollution](#)
[224:1400](#)

Online Date

January 2013

DOI

10.1007/s11270-012-1400-5

Print ISSN

0049-6979

Online ISSN

1573-2932

Publisher

Springer Netherlands

Additional Links

- [Register for Journal Updates](#)
- [Editorial Board](#)
- [About This Journal](#)
- [Manuscript Submission](#)

Topics

- [Environment, general](#)
- [Atmospheric Protection/Air Quality Control/Air Pollution](#)
- [Waste Water Technology / Water Pollution Control / Water Management / Aquatic Pollution](#)
- [Soil Science & Conservation](#)
- [Hydrogeology](#)
- [Climate Change](#)

Keywords

- Trickle Filter
- Tributyltin
- Removal
- Biodegradation
- Wastewater

Industry Sectors

- [IT & Software](#)
- [Electronics](#)
- [Oil, Gas & Geosciences](#)
- [Engineering](#)
- [Aerospace](#)
- [Telecommunications](#)
- [Chemical Manufacturing](#)
- [Automotive](#)
- [Energy, Utilities & Environment](#)
- [Consumer Packaged Goods](#)

Authors

- [M. D. Scrimshaw](#) ⁽¹⁾
- [D. Hala](#) ⁽¹⁾
- [A. E. Okiemute](#) ⁽¹⁾
- [E. Cartmell](#) ⁽²⁾
- [J. N. Lester](#) ⁽²⁾

Author Affiliations

- 1. Institute for the Environment, Brunel University, Middlesex, UB8 3PH, UK
- 2. Cranfield Water Science Institute, School of Applied Sciences, Cranfield University, Bedfordshire, MK43 0AL, UK

Continue reading...

To view the rest of this content please follow the download PDF link above.

Over 8.5 million scientific documents at your fingertips
Browse by Discipline

1. [Architecture & Design](#)
2. [Astronomy](#)
3. [Biomedical Sciences](#)
4. [Business & Management](#)
5. [Chemistry](#)
6. [Computer Science](#)
7. [Earth Sciences & Geography](#)
8. [Economics](#)
9. [Education & Language](#)
10. [Energy](#)
11. [Engineering](#)
12. [Environmental Sciences](#)
13. [Food Science & Nutrition](#)
14. [Law](#)
15. [Life Sciences](#)
16. [Materials](#)
17. [Mathematics](#)
18. [Medicine](#)
19. [Philosophy](#)
20. [Physics](#)
21. [Psychology](#)
22. [Public Health](#)
23. [Social Sciences](#)
24. [Statistics](#)

Our Content

- [Journals](#)
- [Books](#)
- [Book Series](#)
- [Protocols](#)
- [Reference Works](#)

Other Sites

- [Springer.com](#)
- [SpringerImages](#)
- [SpringerProtocols](#)
- [SpringerMaterials](#)
- [SpringerReference](#)

Help & Contacts

- [Contact Us](#)
- [Feedback Community](#)
- [Impressum](#)

Legal

© Springer, Part of Springer Science+Business Media [Privacy Policy, Disclaimer, General Terms & Conditions](#)

Not logged in Unaffiliated 69.164.169.86

Springer for Research & Development

<div id="jsnotice" class="prompt-bar"> & lt;p> JavaScript is currently disabled, this site works much better if you enable JavaScript in your browser. </p> </div> <div id="webtrekk"> </div>



LIFE02 ENV/B/000341

SCREENING OF TECHNOLOGIES

08/04/2003

TBT CLEAN



TABLE OF CONTENTS

EXECUTIVE SUMMARY	6
1. INTRODUCTION	7
1.1. Use of TBT	7
1.2. Physical and chemical properties	10
1.2.1. Highly lipophilic character and quick degradation in water	10
1.2.2. Parameters influencing TBT-distribution between organic matter and water.....	10
1.3. Eco-toxicity of TBT.....	12
1.4. Alternatives for TBT.....	12
1.5. Conventions and legislation on TBT	13
2. OVERVIEW OF TECHNOLOGIES.....	14
2.1. Basic principles of TBT-degradation	14
2.1.1. Pathway of TBT-degradation.....	14
2.1.2. Parameters influencing degradation.....	14
2.1.3. Removal of TBT	16
2.1.4. Overview of technologies: introduction.....	16
2.2. Effects of dredging activities on persisting TBT-release.....	18
2.3. Pre-treatment: Concentration and separation of TBT-contamination.....	19
2.3.1. Physico-chemical washing and separation.....	19
2.4. Sludge treatment techniques	21
2.4.1. Land Disposal or Land Farming (Brandsch et al., 2001).....	21
2.4.2. Thermal treatment by evaporation of TBT	22
2.4.3. Thermal treatment by pressure thermolysis of TBT	22
2.4.4. Electro-chemical oxidation	25
2.4.5. Bio-remediation	28

2.4.6.	Phyto-remediation.....	29
2.5.	Water treatment techniques.....	30
2.5.1.	Photo-oxidation processes	30
2.5.2.	Removal by means of activated sludge.....	34
2.5.3.	Removal by means of activated carbon	35
2.5.4.	Solvent extraction of TBT (Ashcroft and Abel, 1999)	37
3.	CONCLUSIONS.....	39
3.1.	Overview of sludge treatment technologies.....	40
3.2.	Overview of water treatment technologies	41
4.	SUGGESTIONS FOR FURTHER INVESTIGATIONS	42
4.1.	Sludge treatment technologies	42
4.2.	Water treatment technologies	43
5.	REFERENCES	44

LIST OF TABLES

Table 1: Overview of TBT-concentrations in sediment ($\mu\text{g Sn/kg DW}$), measured in Flemish harbours, dockyards and waterways (VMM, 2001).....	9
Table 2: Overview of TBT-concentrations in surface water (ng Sn/l), measured in Flemish harbours, dockyards and waterways (VMM, 2001).....	11
Table 3: Half-lives of TBT-degradation in different media.....	14
Table 4: Reduction of different butyltin compounds by electrochemical oxidation.....	26
Table 5: Contaminant removal efficiencies in an industrial scale ion exchanging and UV-radiation unit.....	34
Table 6: Average concentrations of organotins in wastewater, at different stages of treatment, and in digested sludge.....	35

LIST OF FIGURES

Figure 1: Equipment for physico-chemical washing and separation by hydro-cyclone (ENVISAN)	Fout! Bladwijzer niet gedefinieerd.
Figure 2: Installation for thermal treatment of TBT by evaporation and oxidation (ENVISAN)	Fout! Bladwijzer niet gedefinieerd.
Figure 3: Projection of a full-scale pressure thermolysis unit	23
Figure 4: Flow sheet of a pilot scale electrochemical oxidation unit for TBT	27
Figure 5: Pilot test results of TBT-removal by UV-radiation.....	32
Figure 6: Flow sheet of industrial scale equipment for removal of TBT, Cu & Zn.....	33
Figure 7: Flow sheet of a TBT removal installation by flotation (DAF) and active carbon (GAC)	36
Figure 8: Flow sheet of an installation for TBT removal by solvent extraction	38

LIST OF ANNEXES

- Annex 1 Reed J., Waldock M.J., Jones B., Blake S., Roberts P., Jones G., Elverson C., Hall S., Murray L.: *Remediation techniques applied to reduce paint-derived tributyltin in dredged material*, Physical – Chemical Remediation, 2002 . 46
- Annex 2: Brandsch R., Nowak K.E., Binder N., Jastorff B.: *Investigations concerning the sustainability of remediation by land deposition of tributyltin contaminated harbour sediments*, J Soils & Sediments 1(4) 234-236, 2001 47
- Annex 3: Mostofizadeh Ch.: *Elimination of TBT compounds from dredged material by means of pressure thermolysis*, Institute of Energy and Process Technology (IEV), Bremerhaven, 2001 48
- Annex 4: Stichnothe et al., 2001 & 2002:..... 49
- Annex 5: Fletcher L.E. & Lewis J.A.: *Regulation of shipyard discharges in Australia and the potential of UV oxidation for TBT degradation in washdown waste water* Proceedings of Oceans '99 Congress, p. 27 - 35 50
- Annex 6: Fox T.J., Beacham T., Schafran G.C., Champ M.A.: *Advanced technologies for removing TBT from ship washdown and drydock runoff wastewaters*, Proceedings of Oceans '99 Congress, p.63-71..... 51
- Annex 7: Ashcroft P.L., Abel D.: *Process Water Treatment for the removal of TBT in ship wash down wastewaters*, Proceedings of Oceans '99 Congress, p.73 - 75 52

EXECUTIVE SUMMARY

Within the framework of the TBT-Clean- project (LIFE 02 ENV/B/000341), a screening of literature had to be performed, in order to make an overview of technologies that exist nowadays for sustainable removal of tributyltin-contamination from sediments and surface water.

This literature review first gives an overview of the main physical, chemical and ecotoxicological properties of tributyltin (TBT), so that the fate and degradation of this chemical can be understood. A description is given of the use of TBT, the alternatives that are available nowadays, and the conventions and legislation related to TBT. The review also discusses the possible effects of dredging of TBT-contaminated sludge on TBT-release.

Degradation and transformation of TBT occur through a mechanism of sequential debutylation. The main abiotic factors that enhance the tributyltin degradation process are: transfer from solid phase to liquid phase, oxygen concentration, sunlight (UV-radiation), temperature and pH.

The literature review focuses on treatment technologies for removal of TBT from sediment and water.

Concerning the solid phase (dredging sludge), the following technologies are discussed: physico-chemical (pre-)treatment, disposal on land, thermal treatment (by evaporation and by pressure thermolysis), electro-chemical oxidation, bio- and phyto-remediation.

Pressure thermolysis, and mainly electrochemical oxidation seem promising technologies: they have been tested at least on pilot scale, the TBT-removal efficiency is up to 99% or higher, the degradation process is running quickly (a few hours) and the cost is equal to or lower than 15€/tonne.

Concerning the liquid phase (mainly rinsing water from dry docks), the following technologies are considered: photo (UV)-oxidation, activated carbon filtration, removal by activated sludge, and solvent extraction.

Activated carbon filtration and removal by activated sludge only displace the TBT-contamination from one phase to another. UV-oxidation and solvent extraction, on the other hand, seem very promising as water treatment technologies: they have been tested on full scale, the TBT-removal efficiency is up to 99,9%, the degradation process is running quickly (a few hours) and the cost might be lower than 7 €/m³ (for solvent extraction; cost may be low for UV-oxidation if O₃ is used instead of H₂O₂, and if O₃ is generated on site).

1. INTRODUCTION

1.1. Use of TBT

(EXTOXNET, 1996; Fent, 1996; Tam et al, 2002; WWF, 2002)

Tributyltin (TBT) is an organotin compound, consisting of three butyl-side chains, covalently bonded to one tin (Sn) central atom. Organotin compounds can exist as mono-, di-, tri-, and tetra- substituted analogues.

Organotins were formerly employed mainly as pesticides, but also found important non-pesticidal applications, namely as poly-vinyl chloride-stabilisers and catalysts for poly-urethane and silicon elastomers. A pie diagram showing the relative distribution of organotin consumption is presented in Figure 1. It shows the annual consumption of 35.000 tonnes of organotins in 1985, prior to regulation of antifouling paints.

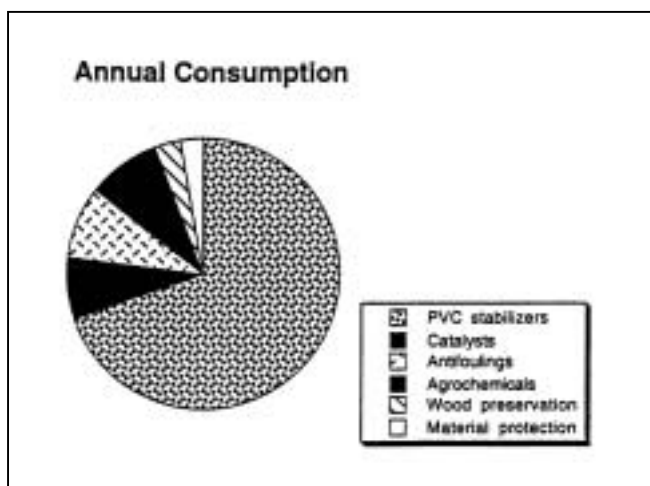

Figure 1: Estimated annual consumption of organotins in 1985

Mainly the application as antifouling agent on ship's hulls, has recently made tributyltin as a contaminant of global concern. As the vessel moves through the water, TBT is released very slowly from the polymer matrix of the paint layer by a process of self-polishing. The highly toxic effect on settling water organisms prevents them from sticking on the ship's hull. Swain (1999) mentions a biocide output of $4\mu\text{g}/\text{cm}^2\cdot\text{day}$. For example, a 65.000 Gross Registered Ton container ship with a length of 260m, has an approximate wetted surface of 13.000m^2 . So the TBT input into the environment is about 190 kg/year.

On the other hand, tributyltin is also extremely toxic for a wide variety of non-target aquatic organisms. It has been proved that tributyltin is highly toxic for shellfish and other sea organisms, even at very low concentrations, as found in waterways outside dockyards. Therefore the International Maritime Organisation has adopted a treaty concerning the limitation of harmful antifouling paints on

ships, additional to the European Directive 1999/51/EC (see point 1.5 for more details)

Because of the strong tendency to adsorb to sediment particles, TBT is detected in significant concentrations in sediments along busy maritime traffic routes and in port and harbour docks. Besides, important concentrations might be detected in ship repair yards, as a consequence of the removal of old and applying of new layers of TBT-containing paint. This phenomenon has also occurred in Flemish harbours, dockyards and waterways. This is shown by Table 1, which presents results of measurements of sediment and sludge.

IVM-code	Spuikom O	Spuikom B	Zeebrugge	Zeebrugge	Zeebrugge	Spuikom	Spuikom	Haven	Haven
Location	Oostende	Bredene	Vissershaven	Vissershaven	Vissershaven	Bredene	Oostende	Antwerpen	Antwerpen
	170005	170004	325	325	325	770004	770005	806200	806200
Sampling date	13/11/00	13/11/00	14/11/00	14/11/01	08/01/01	08/01/01	08/01/01	11/01/01	23/11/00
monobutyltin	21	11	27	30	70	8	27	500	800
dibutyltin	19	6	50	40	100	4	26	2100	3100
tributyltin	27	4*	300	400	1400	3	30	51800	52800
monofenyltin	3	1*	2	2*	5	0,4	4	300	90
difenyltin	<0.4	<0.8	<0.5	<0.5	2	<0.1	0,5	80	40
trifenyltin	1*	<0.8	3	3	6	0.3*	3	500	200
dicyclohexyltin	<0.4	<0.8	<0.5	<0.5	<0.3	<0.2	<0.2	<0.2	<0.2
tricyclohexyltin	<0.4	<0.8	<0.5	<0.5	<0.6	<0.3	<0.4	<0.3	<0.4
fenbutatinoxide	<0.4	<0.8	<0.5	<0.5	<1	<0.5	<0.7	<0.6	<0.6
Weight of dry material (g)	4,6	2,4	4,2	4,2	2,3	4,0	3,2	4,0	3,5
Dry Weight	30%	16%	28%	28%	23%	40%	31%	39%	35%

Table 1: Overview of TBT-concentrations in sediment ($\mu\text{g Sn/kg DW}$), measured in Flemish harbours, dockyards and waterways (VMM, 2001)

1.2. Physical and chemical properties

(Fent, 1996; Mink, 2000; Uhler et al., 2000)

1.2.1. Highly lipophilic character and quick degradation in water

The fate and transport properties of TBT are similar to non-polar or moderately polar organic substances. This is due to TBT⁺ having some polar characteristics, because of the central Sn atom which is positively charged, but also having non-polar lipophilic butyl groups. This means that this substance has in fact a highly lipophilic character. Therefore, TBT has a strong tendency to accumulate in the organic tissue of aquatic organisms, and adsorb to the sediment, both to the inorganic fraction (clay, iron-hydroxides, etc.) as to the organic fraction.

Therefore also, no relevant TBT-concentrations are to be expected in surface water. Moreover, the relatively quick degradation in the water phase still lowers the actual concentrations in water. This is confirmed by measurements that have been executed in several Flemish harbours, dockyards and waterways in the period November 2000 – January 2001, by the Flemish Environmental Company (VMM). This is shown by Table 2, which presents results of measurements of surface water. No tin-concentrations higher than detection limit were found in the surface water. In the sediment however, (see Table 1), relevant concentrations have been detected. (VMM, 2001)

1.2.2. Parameters influencing TBT-distribution between organic matter and water

The bonding of TBT to the sediment, however, is not irreversible. A transfer of TBT from the solid to the liquid phase can be induced by shaking. Fent (1996) reports that vigorously shaking during 3 days releases about 80% of TBT sorbed to sediments.

The n-octanol/water partition-coefficient (n-octanol being considered as a surrogate for organic matter) strongly depends on local circumstances such as pH, conductivity, etc. Partition-coefficients reported for TBT range from 340 to 390.0000 l octanol/ kg water. (Uhler *et al.*, 2000), depending upon these parameters.

At high salt concentrations, mainly the bonding to the organic fraction becomes important. Under influence of salt, an ion exchange process occurs. Stichnothe *et al.* (2001) have proved this in several experiments. Batch extraction tests were carried out to investigate whether the adsorbed butyltin species could be redissolved in the aqueous phase. The sediment was suspended in a 1M and a 5M NaCl solution and stirred for 36h to determine the maximum desorption rate. It appeared that the extraction rate was approximately four times higher in a 5M NaCl solution than in a 1M solution.

The water solubility of tributyltin, on the other hand, is strongly affected by pH. TBT's solubility ranges from 750 to 31.000 mg/l over the pH-range of 2,6 to 8,1. (Uhler *et al.*, 2000)

IVM-code	786WA001	786WA002	786WA003	786WA004	786WA005	786WA006	786WA007	786WA011	786WA012	786WA013	786WA014	786WA015	786WA016	786WA017
Location.	Spuikom Oostende 77005	Zeebrugge Vissershaven 325	Leie 576000	Spuikom Bredene 770004	Gaversbeek 630000	Mandel 603000	Yzer 916000	Zeebrugge Vissershaven 325	Leie 576000	Mandel 36899 603000	Gaversbeek 630000	Bredense Spuikom 770004	Spuikom Oostende 77005	Yzer 916000
Sampling date	13/11/00	14/11/00	16/11/00	13/11/00	16/11/00	16/11/00	16/11/00	08/01/01	08/01/01	08/01/01	08/01/01	08/01/01	08/01/01	08/01/01
monobutyltin	<6	<6	<6	<6	<6	<6	<6	<6	<6	<6	<6	<6	<6	<7
dibutyltin	<3	<3	<3	<3	<3	<3	<3	12*	<6	<5	<6	<5	<6	<7
tributyltin	<3	<3	<3	<3	<3	<3	<3	13*	<5	<5	<5	<5	<5	<6
monofenyltin	<1	<1	<1	<1	<1	<1	<1	<5	<5	<5	<5	<5	<5	<6
difenyltin	<3	<3	<3	<3	<3	<3	<3	<5	<5	<5	<5	<5	<5	<6
trifenyltin	<2	<2	<2	<2	<2	<2	<2	<2	<2	1.8*	3.6*	<2	<2	3.3*
hh. water (liter)	0,50	0,50	0,50	0,50	0,50	0,50	0,50	0,51	0,50	0,51	0,50	0,50	0,50	0,42

Table 2: Overview of TBT-concentrations in surface water (ng Sn/l), measured in Flemish harbours, dockyards and waterways (VMM, 2001)

1.3. Eco-toxicity of TBT

(EXTOXNET, 2002; Fent, 1996; Linley-Adams, 1999 Mink, 2000; ; ORTEPA, 2002; Uhler et al., 2000)

The following effects of TBT on aquatic fauna are reported: slower growth rate and shell deformation of mussels and oysters; sex mutation, sterility of sea snails, and toxicity towards many other biota. In general TBT appears to have a hormone disturbing effect. E.g. female endocrine systems of the common dog whelk (*Nucella lapillus*) are disrupted leaving them unable to metabolise testosterone to oestrogens. This results in the growth of male sex organs (penis and vas deferens), which over-grow the female oviduct. This phenomenon is called *imposex*.

Besides, one supposes that TBT also has a negative influence on the immune system of bigger mammals, such as sea otters, whales and dolphins. (Fent, 1996)

The Dutch Federal Institute for the Quality of Sea water (RIKZ) reports a value, above which eco-toxicological effects would appear, namely 500 µg TBT /kg DW for sediment. In 1995, the Belgian consultant Ecolas derived a value of 800 µg TBT /kg DW.

In the water phase, TBT has been found to affect female *Nucella* at concentrations of 1ng/l. Sterility was observed at concentrations of 2 ng/l and higher.

This has led to the definition of relatively low concentration goals for TBT in surface water (salt and sweet). For example, the Belgian authorities stated a maximum value of 7µg/kg DW in marine sediment (European Commission, 2000). Concerning the water phase, the US Environmental Protection Agency has established a chronic marine water quality criteria for TBT of 10ng/l. The National Oceanographic and Atmospheric Administration has recommended a chronic concentration of concern for TBT in freshwater of 63 ng/l. (Uhler et al., 2000) The Virginia (USA) discharge limit for TBT in surface water is 50 ng/l.(Fox et al., 1999) To date, no quality nor discharge limit for surface water is of application in Belgium.

It can be remarked that the other organotin compounds have a lower eco-toxicity. The toxicity increases with the number of butyl substitutions from 1 to 3 and then decreases with the addition of the fourth butyl group.(Mostofizadeh, 2001)

1.4. Alternatives for TBT

(Champ, 2001; ORTEPA, 2002; SIGMA, 2002; AMERON, 2002; Hunter & Anderson, 2002; PCI, 2000; Daehne et al., 2000; Watermann et al., 2001; Sectorstar, 2002; Stroudgate, 2002)

As a consequence of the TBT ban, shipping and chemical industry have been searching for practically and economically applicable alternatives, which are at present being commercialised.

Some of these alternatives still use the principle of biocidal activity, while others make use of physical properties to prevent sea-organisms from sticking on ship's hulls:

- Copper-based antifouling paints: These products were widely used before TBT, but nearly as toxic when allowed to bio-accumulate in the marine environment. They are also not as effective as TBT.
- Bio-active compounds, such as seaweeds, sea squirts and corals: they produce natural chemicals which inhibit settling organisms.
- Silicone coatings, which create a non-stick surface.
- Micro-fibre coatings: these are micro hair coverings, painted onto ship hulls. They prevent organisms from attaching strongly, so that they will be washed off when vessels reach certain speeds.

Thanks to the possibility of using alternative antifoulants when legislation restricts the use of TBT, it will be possible to prevent future TBT pollution from point sources such as ship repair and dockyards.

A further evaluation of TBT-alternatives is carried out in the framework of the TBT-Clean project. The evaluation will provide an overview of TBT alternatives for TBT as antifouling, on the basis of their risk assessment outcome, overall environmental impact, etc.(task State-of-the-art on TBT alternatives).

1.5. Conventions and legislation on TBT

(Champ, 2000,Champ, 2001; Champ, 2002; JOTUN, 2002)

It is obvious that the regulation of the use of TBT-containing antifouling paints should be implemented at an international level. An important step has been taken in October 2001, when actors within the International Maritime Organisation (IMO) agreed upon an international treaty concerning the limitation of harmful antifouling paints on ships.

The use of TBT and other organotin compounds in antifouling paints is internationally forbidden as from the 1st of January 2003. As of 2008, no more organotin compounds are allowed on ships' hulls. This treaty is additional to the European Directive 1999/51/EC, which bans the use of these compounds on inland ships and on sea ships with a length of less than 25 m.

The ratification of this treaty, in combination with the growing availability of alternatives, should result in an important reduction of TBT emissions to the surface waters and of the concentration of TBT in sediments, in the years to come. This will make it worthwhile to start with the clean-up of TBT-polluted dredging sludge.

2. OVERVIEW OF TECHNOLOGIES

2.1. Basic principles of TBT-degradation

2.1.1. Pathway of TBT-degradation

Tributyltin is readily degraded, both biologically as physico-chemically, if proper conditions are applied. Degradation and transformation occur through a mechanism of sequential debutylation. This means that the butyl-chains are removed one by one, with dibutyltin and monobutyltin as intermediate forms. This process will eventually lead to the liberation of inorganic tin.

2.1.2. Parameters influencing degradation

The main abiotic factors enhancing tributyltin degradation are: (Brandsch et al., 2001, Fletcher & Lewis, 1999)

- Transfer from solid to liquid phase
- Oxygen concentration
- Sunlight (UV-radiation)
- Temperature
- pH

2.1.2.1. Transfer from solid to liquid phase

The half-life of the organotin compounds strongly depends upon the circumstances, i.e. the degradation occurs rather quickly in the water phase, but is relatively slow in anaerobic circumstances in sediments, as shown in Table 1 (Uhler et al., 2000, Fent, 1996, Mink, 2000).

Medium	Half-life
Water	1 – 3 weeks
Sediment, aerobic conditions	1 – 2 years
Sediment, anaerobic conditions	2 – 10 years

Table 3: Half-life of TBT in different media

Also, if only biological degradation is considered (without photolysis, see further), the degradation rate in water, under the same conditions as in sediments (e.g. TBT-concentrations, temperature, oxygen-concentrations) is almost 4 times higher than in sediment (Brandsch et al., 2001). This can be explained by the fact that contaminants in the water phase are easier accessible for degrading organisms than in sediment.

The transfer of TBT from the solid to the liquid phase can be accomplished in two ways:

- Mechanically, by vigorously shaking during 3 days (Fent, 1996)
- Chemically, by increasing salinity, which induces an ion exchange process (Stichnothe *et al.*, 2001)

These transfer mechanisms have been explained in section 1.2.2

2.1.2.2. Increase of oxygen concentration

Brandsch et al. (2001) have set up an experiment with land deposition of TBT-contaminated dredging sludge. Without any treatment, the TBT-content of the sediment decreases only 10% per year. If the sediment was restacked regularly (for a better access of air oxygen - land farming) the decrease in TBT-concentration is up to 30% per year.

2.1.2.3. Increase of sunlight (UV-radiation)

Fletcher and Lewis (1999) have shown that TBT compounds are susceptible to photo-degradation.

Under influence of sunlight hydroxyl radicals are produced. These radicals react at the tin-carbon bond, and remove one butyl group each time. If one uses UV-radiation instead of visible sunlight, the TBT-degradation is accelerated.

The presence of a strong oxidant, such as hydrogen peroxide or ozone, is necessary as a source of hydroxyl radicals. Otherwise, no photo-degradation will occur.

2.1.2.4. Raising of temperature

Experiments executed by Brandsch et al. (2001), show that the degradation of TBT in sediment under aerobic conditions, is strongly influenced by temperature: the half-life of TBT in a sediment with 320 µg/kg DW decreased from 90 weeks at 5°C, to 4 weeks at 55°C. Sediment with 320 µg TBT/kg DW was kept at 55°C (in

aerobic conditions) during 7 months, and a complete degradation of TBT took place (no measurable concentration left, detection limit = 1 µg/kg DW).

2.1.2.5. Raising of pH

The degradation of TBT is also influenced by pH (Fletcher & Lewis, 1999). Experiments with photo-catalytic oxidation show that TBT half-life is decreasing significantly (from 24.8 to 2.7 minutes) with increasing pH (from pH 5.5 to pH 12.6). This is also directly influenced by the fact that TBT's water solubility is strongly affected by pH. It ranges from 750 to 31.000 mg/l (Uhler *et al.*, 2000) over the pH-range of 2,6 to 8,1 (see also section 1.2.2).

2.1.3. Removal of TBT

Instead of degrading TBT *in-situ*, it is also possible to simply *remove* it from the solid or the liquid phase, and treat it *ex-situ*.

Therefore one can make use of the strong binding tendency of TBT to non-polar matter. Furthermore, if this non-polar matter has strong adsorption capacities, such as activated carbon for example, TBT can be removed with a high efficiency. (Fox *et al.* 1999)

2.1.4. Overview of technologies: introduction

This chapter contains an overview of technologies that might be useful to remove TBT from dredging sludge and from dockyard wastewater, and that make use – in one way or another- of the above-mentioned basic principles. All these technologies have been tested at least on laboratory scale. The results obtained from these tests were promising for every technology, and some of them have been tested on full scale, but to date, no technology is operational yet in real industrial conditions.

The first step to take in the remediation of sludge is the dredging of the TBT contaminated sediment. The dredging activity is a possible cause of release of TBT into the aquatic environment. Therefore a separate paragraph will pay attention to the possible effects.

After dredging the sediment, it is useful to separate contaminated from non-contaminated sludge. Several physico-chemical techniques can be used to realise these separation and to concentrate TBT-contamination.

In a third step the treatment technologies as such will be discussed. A distinction will be made between technologies for sludge and for water treatment.

Concerning the solid phase (dredging sludge), the following technologies will be discussed:

- Disposal on land
- Thermal treatment by evaporation
- Thermal treatment by pressure thermolysis
- Electro-chemical oxidation
- Bio-remediation
- Phyto-remediation

Concerning the liquid phase (mainly rinsing water from dry docks), the following technologies can be considered:

- Photo-oxidation
- Activated carbon filtration
- Removal by activated sludge
- Solvent extraction

2.2. Effects of dredging activities on persisting TBT-release

The following phenomena can have effect on the fate of TBT during dredging activities:

- Transfer of TBT from solid to liquid phase
- Bio- and photo-degradation of TBT in the liquid phase
- Acceleration of degradation in aerobic conditions

Since the bonding-tendency of TBT to organics and fine sediment is very strong, there will be only little of TBT released to the water phase. As Fent showed in 1996, vigorous shaking during 3 days is needed to release most of TBT adsorbed to sediments.

The small fraction of TBT being released into the water will be degraded very quickly. Brandsch *et al.* (2001) proved that degradation, apart from photo-degradation, goes 4 times faster in water than in sediment.

Because of the mixing of the sludge, caused by dredging activities, oxygen might be introduced into the sludge, resulting in the creation of aerobic conditions. Also this effect is favourable for degradation of TBT, since the degradation rate is 3 times higher in aerobic than in anaerobic sediment. (Brandsch *et al.*, 2001)

So, as far as can be concluded from this limited list of possible effects, and based on phenomena observed mainly in laboratory conditions, no negative effects on persisting TBT-release into aquatic environment would be expected. Nevertheless, further investigations on operational scale are necessary to confirm these observations. They will be executed within the framework of this TBT-Clean project.

2.3. Pre-treatment: Concentration and separation of TBT-contamination

2.3.1. Physico-chemical washing and separation

2.3.1.1. Theoretical background

A first step in remediation of TBT-contaminated sludge is the separation of contaminated and non-contaminated fractions.

Tributyltin links preferentially to organic matter of sediment. Organic matter usually has a low density. Furthermore, TBT-particles concentrate in a sludge fraction with similar particle size. For example, paint particles will concentrate in the sediment fraction with large particle size (Reed et al., 2002, see also Annex 1).

So, if the light (low density) and large particle sized (in case of paint particles) fraction of the sludge can be separated from the heavy and small particle sized fraction, there will be a concentration of TBT in a smaller volume of sludge, which can be treated in a next step.

2.3.1.2. Technical execution

Two physico-chemical techniques can be applied for washing and separation

- Hydro-cycloning
- Froth flotation

These techniques separate fractions of different particle sizes and densities.

Results of the tests executed by Reed *et al.* (2002) showed that the highest concentrations of TBT are associated with the light fractions. Depending on the size of the paint particles, they concentrate in larger or smaller particle size classes.

The most important result from these separation processes is that it has been proven possible to isolate the TBT-contaminated component of the sediment, leading to a 60 – 70 % reduction of the volume of the contaminated sample.

The technologies for hydro-cycloning and froth flotation exist, but the equipment still has to be tested on TBT-contaminated sludge.

The following remark can be made concerning the chemical process of dewatering in a filter press: Dependence of TBT solubility on pH could suggest that the use of $\text{Ca}(\text{OH})_2$ or CaCO_3 as flocculants might make it possible to wash out contamination inside a filter press or another dewatering or separation device.

The addition of $\text{Ca}(\text{OH})_2$ or CaCO_3 raises the pH. As TBT-solubility in water increases with increasing pH (see section 1.2.2), TBT can be washed out of the sludge. Also the photo-catalytic oxidation significantly improves with increasing pH. (see section 2.1.2.5)

Nevertheless, no data of any test could be found.

2.4. Sludge treatment techniques

2.4.1. Land Disposal or Land Farming (Brandsch *et al.*, 2001)

2.4.1.1. Theoretical background

As explained in chapter 2.1.2, degradation of TBT is influenced by oxygen concentration and temperature. If temperature is raised, then the speed of TBT-degradation will increase. A similar phenomenon occurs when oxygen concentration is raised.

Furthermore, tributyltin has a very strong tendency to adsorb to (organic) sediment. Therefore it is possible to bring TBT-contaminated sludge on land (e.g. for disposal or remediation reasons) without too much of risk for release of TBT.

2.4.1.2. Technical execution

Brandsch *et al.* (see also Annex 2) have executed a number of laboratory experiments to prove whether land disposal of TBT-contaminated sludge is a sustainable solution or not.

When sludge is brought to land, without any further action, there will be a degradation rate of about 10% per year.

Regularly restacked sediment, with better contact to air and thus mainly aerobic, shows a degradation efficiency of around 30% after 10 months.

If the temperature of sludge in aerobic condition is raised, the degradation rate will also increase. The half-life of TBT in sediment with 320 µg/kg DW decreased from 90 weeks at 5°C, to 4 weeks at 55°C. When the same sediment was kept at 55°C in aerobic conditions during 7 months, a complete degradation of TBT took place (no measurable concentration left, detection limit = 1µg/kg DW).

On the other hand, an increase of original TBT-concentration seems to increase half-life. A sediment with a concentration of 6.600 µg/kg DW appeared to have a TBT-half-life of 78 weeks at 5°C, which is a bit faster than the 320 µg/kg DW sediment, and 7 weeks at 55°C, which is almost the double of the 320 µg/kg DW. Anyway, if degradation half-life is not lower at higher TBT-concentrations, the time for total degradation will be significantly longer when starting with higher influent-concentrations.

The effects to the surrounding environment were very low: there was no significant change in the TBT-concentration of ground water, surrounding area, adjacent river water or sediment, which could have resulted from the deposited sediment.

There was also no considerable uptake of TBT in plants.

Concluding the presented evidences, it appears that land deposition of TBT-contaminated sludge is a sustainable solution. But it should be applied only to

moderately contaminated sediments, since the time for total TBT-degradation will increase with increasing start-concentrations.

2.4.2. Thermal treatment by evaporation of TBT

2.4.2.1. Theoretical background

TBT has a high volatility and a relatively low boiling point, of 170 °C.

Therefore thermal treatment, i.e. evaporation from the solid phase to the gas phase, might be considered.

2.4.2.2. Technical execution

Possible equipment for thermal treatment might consist of a soil desorber, with a subsequent oxidiser. The soil desorber evaporates TBT (and other volatile compounds) to the gas phase, which is lead to the oxidiser. In this latter equipment the tributyltin is oxidised to harmless carbon-compounds and tin.

This way of treatment is existing and has extensively been tested on sludge with several volatile contaminations, but not yet on TBT-contaminated sludge.

2.4.3. Thermal treatment by pressure thermolysis of TBT

2.4.3.1. Theoretical background

Investigations in literature (Mostofizadeh^[A33], 2001, see also Annex 3) conclude that organic tin compounds are thermally unstable, and that they disintegrate in the following order:

Tetra-BT → tri-BT → di-BT → mono-BT → Sn
--

The toxicity increases with the number of butyl substitutions from 1 to 3 and then decreases with the addition of the fourth butyl group. Since the di-organotin and the mono- organotin compounds are less toxic than tributyltin, this process might be of interest.

In order to eliminate the TBT, the dredged material can be heated to a higher temperature and kept at this temperature during a dwell period. For energy saving reasons, the treatment is carried out under high pressure, so that no water evaporation occurs.

This process is called “pressure thermolysis”. In comparison to thermal treatment by evaporation, where organotin compounds are evaporated from the solid to the gas phase, the organotin species are degraded by stepwise debutylation. The degradation products remain into the sludge.

Test on lab-scale installations showed that a temperature-time relation of 230°C and 2 hours is needed to get a complete disintegration of TBT and DBT, and most of the MBT compounds. (Mostofizadeh^[A34], 2001)

Based on these results, numerous test trials were executed on a pilot scale unit, in order to optimise the process parameters with regard to adherence to the chemical and biotoxic criteria. The reactor of this pilot scale unit had a volume of 20kg of dredged material. Test runs over a longer dwell period (3h), but at the same temperature (230°C) pointed out that all organotin compounds, included MBT, were degraded to concentrations lower than 1 µg/kgDW, in most of the cases.

Following implementation of the tests, two full-scale units with annual capacities of 85.000 and 170.000 tonnes were designed (but not built) in order to calculate the consumption values and the costs.

2.4.3.2. Technical execution

A drawing of a full-scale installation, erected on a pontoon, is presented in Figure 2

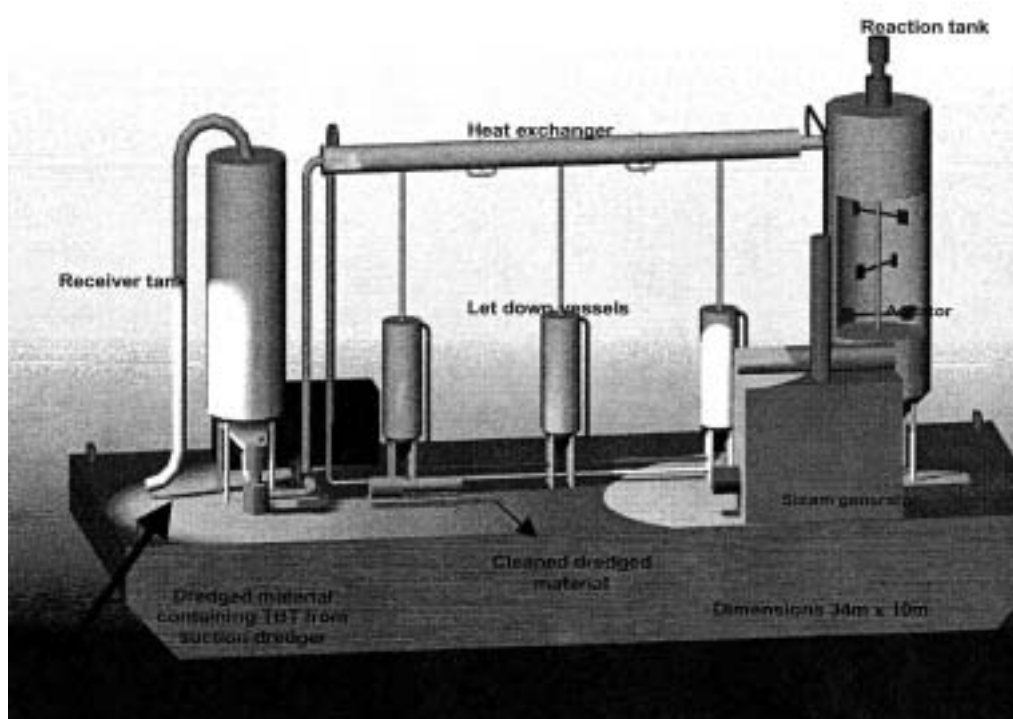

Figure 2: Projection of a full-scale pressure thermolysis unit

The installation consists basically of a reaction tank with heating jacket, in which compressed air and steam are injected to heat the dredged material.

Strip air and steam are drawn off via a pipe and fed into a water-cooled condenser. The condensed water is collected and treated separately.

This is important because volatile phenolic compounds may be present in the sludge.

In order to save energy, the heat from the treated sludge is transferred to the fresh sludge to be introduced in the reactor, by means of a heat exchanger.

The treated sludge is released from the system via so-called let down vessels.

According to the calculations of Mostofizadeh, the energy consumption values of this full-scale equipment will be as follows:

- Thermal energy: 140 kWh/ton
- Electrical energy: 16 kWh/ton

The total treatment cost is estimated to be between 11,5 and 15 €/per ton.

The installation hasn't been built yet.

2.4.4. Electro-chemical oxidation

2.4.4.1. Theoretical background (Stichnothe et al., 2001)

The fate of organotin contamination in sediment is influenced by different factors among which salinity. Increasing salinity generates a process of ion exchange, in which ionic bonds between organotin compounds (e.g. Bu_3Sn^+) and organic matter will be (partially) replaced by sodium-ions. Thus it should be possible to remove the exchangeable part of the organotin compounds from the sediment by ion exchange.

In a second step the organotin compounds can be broken down by means of electrolysis in the aqueous phase. The principle of this technology is to subject the sludge mass to an electric tension. This generates highly reactive radicals, or oxidising species at the electrodes, which attack the bonds between the central tin atom and the butyl ligands. The goal is to oxidise tributyltin to carbon-compounds and tin.

2.4.4.2. Lab-scale experiments (Stichnothe et al., 2001)

Stichnothe and colleagues have compared two different process pathways (see also Annex 4.1):

- A leaching step in a counter-current extraction column, followed by an electrochemical treatment
- A direct electrochemical treatment of suspended sediment (slurry electrolysis)

The first process pathway proved that the extraction phase is strongly influenced by the salinity of the solution: in a 5M NaCl solution, the extraction rate was about 4 times higher than in a 1M NaCl solution.

On the other hand, the extraction process is not enhanced by an increase of the extraction time: equilibrium was reached in approximately 1h. Further prolongation of the extraction process did not release significant supplements of TBT.

In the second step of the first pathway, a stepwise debutylation of the butyltin compounds was accomplished by electrolysis. The degradation efficiency, however, was not very high: TBT could only be reduced from 96.500 to 32.100 $\mu\text{g}/\text{kg}$, which means an efficiency of 67%.

The efficiency of the second pathway, also called slurry electrolysis, was significantly higher: the TBT-concentration decreased from 96.500 to 110 $\mu\text{g}/\text{kg}$ in 24h, while the DBT-concentration increased during the first 4h of the treatment from 4.250 to 6.000 $\mu\text{g}/\text{kg}$, and was then decreased to 2.400 $\mu\text{g}/\text{kg}$. The MBT load increased during the treatment from 890 to 14.000 $\mu\text{g}/\text{kg}$.

Obviously the detoxification mechanism is a stepwise splitting off of the butyl groups, but the process seems to stop, or is at least be strongly inhibited at the MBT-species.

2.4.4.3. Pilot scale experiments (Stichnothe et al., 2002)

Based on the success of the lab-scale experiments, mentioned in point 2.4.4.2, Stichnothe and his colleagues from the Technical University of Hamburg-Harburg and the University of Bremen have executed a pilot-scale investigation on slurry electrolysis (direct electro-chemical oxidation): see also Annex 4.2.

The central part of the installation, the electrolysis cell, had a volume of 30l. The anode area was 2m². A tension of 20V was applied. The current density at the anodes was 80mA/cm².

The main part of this installation is the reactor, in which high current densities are applied between conductor plates. Since TBT is fully oxidised, no special separation phase has to be integrated.

Although process conditions were not optimal, all butyltin compounds could be destroyed below the 100µg/kg limit, as shown in Table 4:

Butyltin compound	Influent concentration (µg/kg)	Effluent concentration (µg/kg)
TeBT	350	< 10
TBT	2.600	< 30
DBT	380	< 100
MBT	570	< 100

Table 4: Reduction of different butyltin compounds by electrochemical oxidation

From these results DBT and MBT seem to disintegrate as well as TeBT and TBT, but Stichnothe *et al.* report that the degradation is much slower for these species.

Also the degradation of other contaminants, which are usually present in harbour sediments, such as PAH, PCB, pesticides and chlorobenzenes, was investigated at the same time. The degradation rate for PAH is approximately 90%. The concentrations of PCB, pesticides and chlorobenzenes, on the other hand, remain identical.

The fate of heavy metals has not been investigated in this study, while former studies have shown that their concentration and mobility are not influenced by this treatment.

2.4.4.4. Further up-scaling experiments (Rehberg et al., 2003)

The Technical University of Hamburg-Harburg is actually (February 2003) finalising a project of stepwise up-scaling of the electro-TBT-detoxification unit as tested before on lab and pilot-scale by Stichnothe et al. (see points 2.4.4.2 & 2.4.4.3).

Initially the process was optimised at the university, with a plant volume of 4m³.

In a second phase a pilot plant with a volume of 160m³ was tested and optimised under actual operating conditions in the harbour. In order to guarantee future applicability, the development activities were performed in close cooperation with the Port Authorities of Hamburg and with the Bremerhaven.

The plant with a volume of 160 m³ has a modular design, providing the possibility to react to varying material flows and/or organotin concentrations. The first container is comprised of the receiving tanks for the untreated and treated dredged materials. The thickened sludge is then transported by means of a screw conveyor from the second tank into a mixing tube, where it is turned into slurry by the addition of water. A third tank (8m³) contains the electro-chemical reaction unit, the galvanostat and the measuring and control unit.

A flow sheet of such an installation is presented in Figure 3 (Stichnothe et al., 2002).

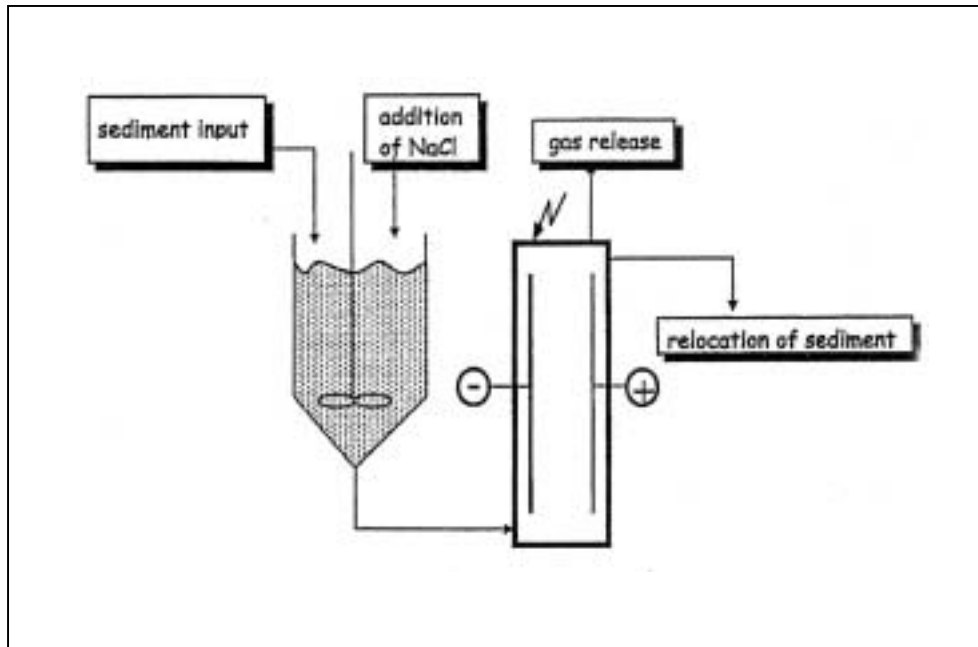

Figure 3: Flow sheet of a pilot scale electrochemical oxidation unit for TBT

Depending on the desired degree of detoxification and residence times, a flow rate from 6 to 30 m³/h should be possible. This should permit the realisation of the complete treatment of dredged materials without any further up scaling by expanding the modules, even for large harbours.

Investigations have been done on three kinds of sludge:

- Sediment from the harbour of Bremen
- Sand fraction of the mechanical dewatering installation METHA
- Organic matter fraction of this mechanical dewatering installation

In every test run TBT-concentration was lowered to less than 100µg/kg. (Stichnothe, 2003). Furthermore, as already shown in the pilot tests, PAH was also degraded, and PCB was not, probably also because the influent concentration was very low. Electrolysis did not have an effect on mobility, nor on the concentration of heavy metals.

The treatment cost was found to approximately 15 €/ton of treated dredged material. The costs for re-start up of the installation after a winter period with freezing temperatures were not integrated in the calculation. (Stichnothe, 2003).

2.4.5. Bio-remediation

2.4.5.1. Theoretical background (Fent, 1996; Harino, H., et al., 1997; Inoue, H., et al., 2000 & 2003; Kawai, S., et al, 1998)

Unless the strong tendency to bind to the solid phase of the sediment, tributyltin is partially biologically available. If microorganisms can be found which are resistant to the generally toxic properties of TBT, this compound might be degraded in a biological way.

Accumulation of TBT and metabolism to DBT, with minor amounts of MBT and Sn was demonstrated for example in the green alga *Ankistrodesmus falcatus*. The estimated half-life for disappearance of TBT is about 25 days.

2.4.5.2. Technical execution

Bio-remediation can be practically realised by active lagunation (liquid phase) or by dry composting.

In both cases inoculation and nutrient addition is necessary. Inoculation by algae looks promising.

2.4.6. *Phyto-remediation*

2.4.6.1. Theoretical background

Comparable to reed plants in wastewater treatment, willow trees do have a high ability to extract TBT from dredging sludge. Inside the plant TBT is metabolised and transformed into harmless carbon-compounds and tin. At the same time the sludge to be treated is dewatered.

Afterwards, the willow trees can be valorised through co-incineration.

2.4.6.2. Technical execution

The technical execution can be compared to reed lands in wastewater treatment. The contaminated sludge is distributed over a bed, filled with drainage pipes. Willow trees are grown on the surface.

This way of treatment has been successfully tested on sludge with other kinds of contamination, but still has to be fully tested on TBT-contaminated sludge.

2.5. Water treatment techniques

2.5.1. Photo-oxidation processes

2.5.1.1. Theoretical background (Fletcher & Lewis, 1999, see also Annex 5)

Studies have shown that TBT compounds are susceptible to photo-degradation. Under influence of sunlight hydroxyl radicals are produced. These radicals react at the tin-carbon bond, and remove one butyl group each time.

Also other oxidative techniques, such as UV-oxidation, electrolytic oxidation and reaction with Fentons reagent, produce hydroxyl radicals, and can be used for the degradation of TBT. These techniques are called enhanced oxidation techniques.

The presence of a strong oxidant, such as hydrogen peroxide or ozone, is necessary as a source of hydroxyl radicals. Otherwise, no photo-degradation will occur.

2.5.1.2. Laboratory scale experiments (Fletcher & Lewis, 1999)

A promising technique for TBT degradation is UV-oxidation. It uses 256nm UV-light to react with either ozone or hydrogen peroxide, which through various chain reactions produces the hydroxyl radical.

The photoreactor, that was used by Fletcher and Lewis, consisted of a 500 W mercury arc lamp, which was suspended over a shallow polycarbonate tank measuring 300 x 150 x 70mm. The tank and light were shielded with polished metal to reflect light into the centre of the photoreactor.

The reactions half-lives observed for UV-oxidation are at least one order of magnitude faster than the results obtained using photo-catalysis with visible light. In the presence of 0.3 ml/l of H₂O₂ 42% at neutral pH, a 1.0 mg/l TBT-acetate solution in deionised water is reduced to half concentration in 0.37 minutes.

Another advantage with regard to visible light oxidation is that the reaction is not confined to a surface.

A disadvantage is the negative influence of increasing turbidity on half-lives. Anyway, reasonable reaction rates can be obtained for real dockyard wash down wastewater, provided some pre-treatment to remove suspended solids.

Also paint composition, and more specifically paint pigment, influences the reaction rate. In particular, the black paint used on submarines slows down reaction rate.

Also organic matter content in the waste (originating from the fouling) has a negative influence on half-life, since hydroxyl radicals may also degrade these organic compounds.

Finally, the need for H₂O₂ 42% can be rather high, in case of treatment of large ships. The dockyard wash down wastewater volume for a big-sized ship can be up

to 2.000.000 litres. At a dosing concentration of 0.3 ml/l of H₂O₂ 42%, about 666 litres of peroxide is needed.

Therefore, for scale-up purposes an ozone generator may be more practical.

2.5.1.3. Pilot scale and industrial scale experiments (Platz et al., 2003)

Platz and his colleagues from Blohm & Voss Repair GmbH have built an industrial scale treatment system to eliminate tributyltin from dock wastewater. In this system also the heavy metals copper (Cu) and zinc (Zn) are treated.

In a preliminary step, the following systems were tested on a semi-industrial scale, on a by-pass stream from the existing wastewater treatment plant:

- For the removal of TBT:
 - Photolysis: exposing the water to UV-light
 - Photo-oxidation: exposing water to UV-light, in presence of H₂O₂
- For the removal of Cu and Zn:
 - Optimised flocculation/precipitation: by addition of hydroxide or sulfide
 - Ion exchange: by means of synthetic resins

For the elimination of TBT, the UV-radiation tests have given satisfactory results, as can be read from the annexed diagram in Figure 4:

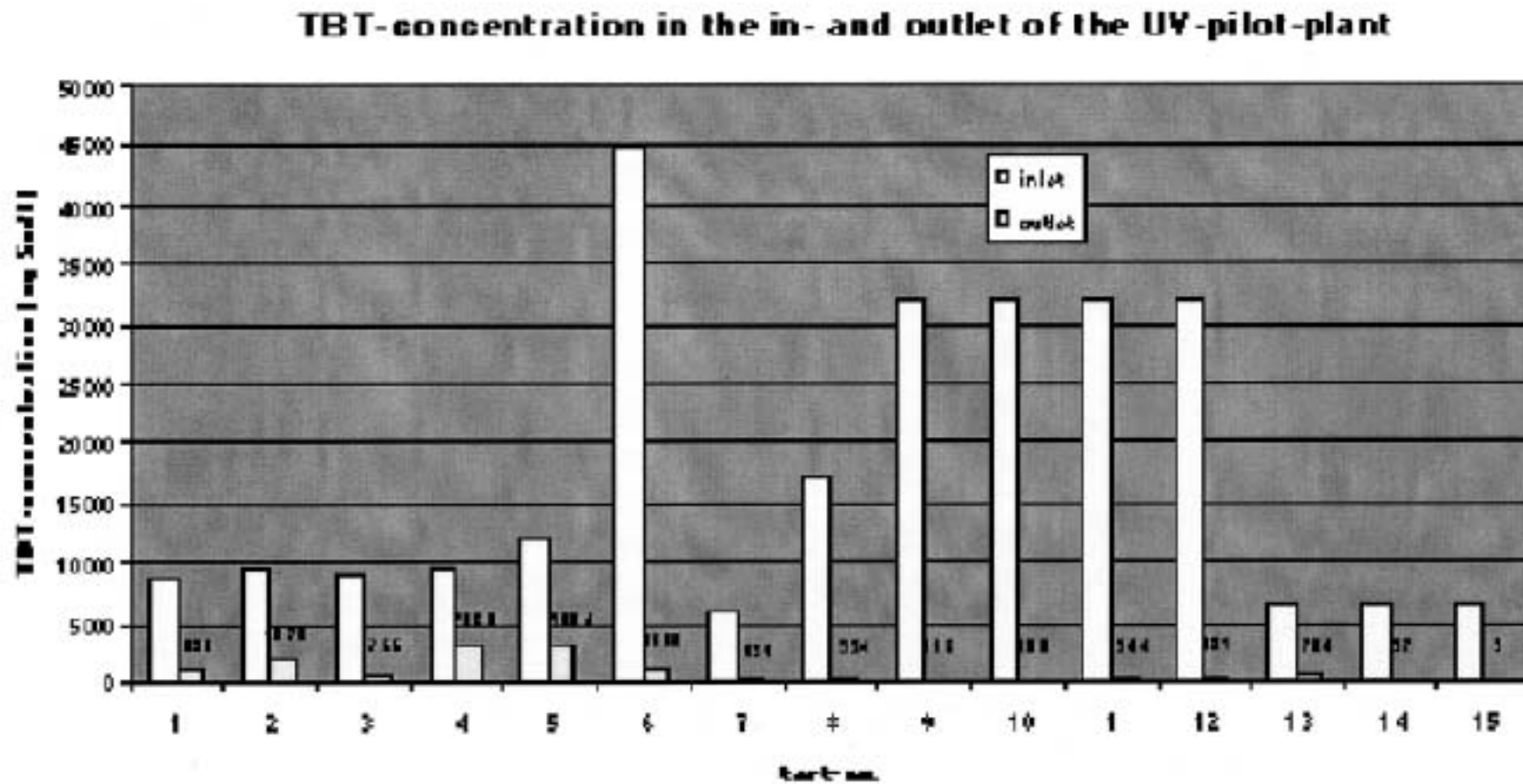

Figure 4: Pilot test results of TBT-removal by UV-radiation

A flow sheet of the industrial scale installation is shown in Figure 5

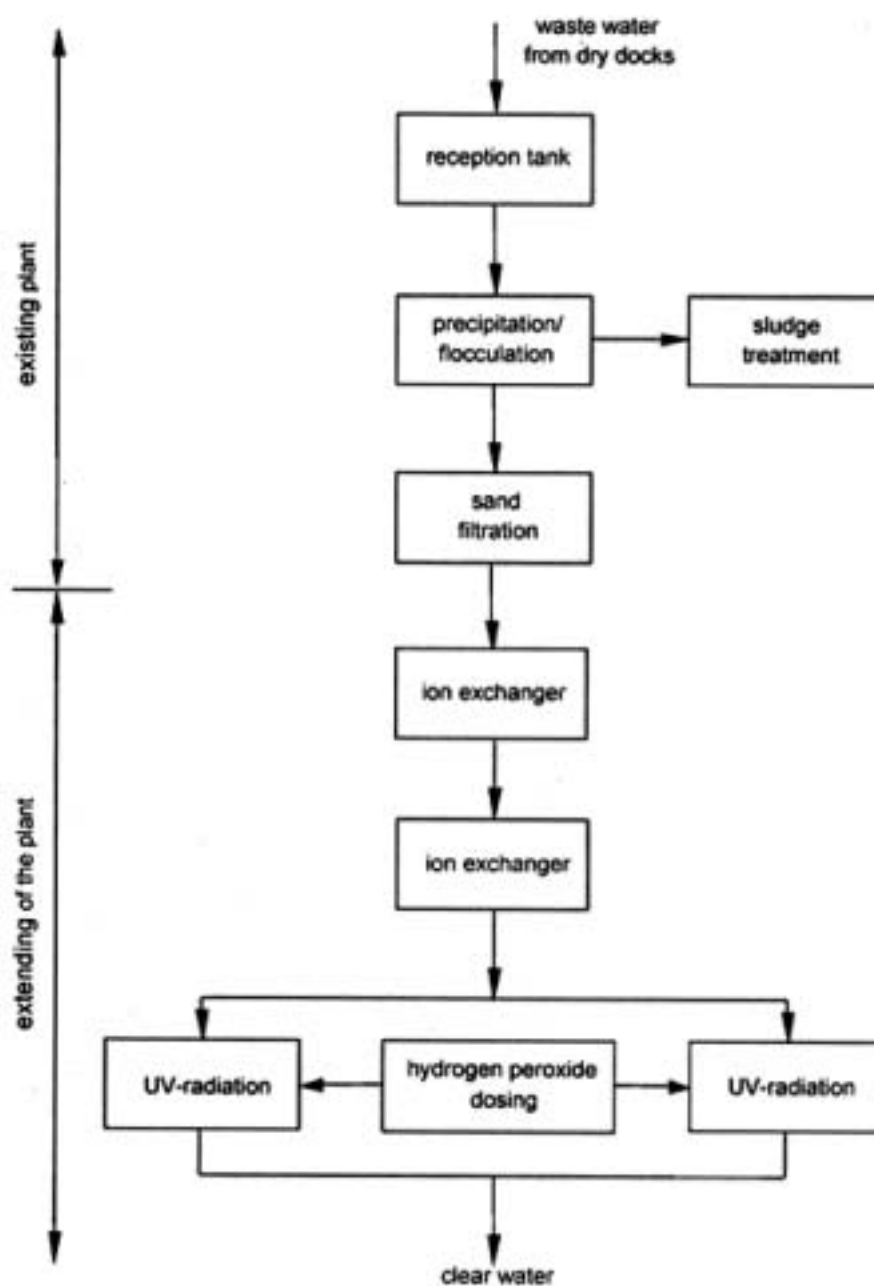

Figure 5: Flow sheet of industrial scale equipment for removal of TBT, Cu & Zn

The existing wastewater treatment plant, consisting of a classic flocculation/precipitation system, followed by a sand filtration, is extended with the following equipment:

- Two serial ion exchangers: to bind heavy metals Cu and Zn
- Two parallel UV-radiation units: to break down TBT

Platz et al. claim the removal efficiencies that are represented in Table 5:

Contaminant	Removal efficiency (%)
Cu	97
Zn	91
TBT	99,9

Table 5: Contaminant removal efficiencies in an industrial scale ion exchanging and UV-radiation unit

2.5.2. Removal by means of activated sludge

2.5.2.1. Theoretical background (Fent, 1996)

The removal of TBT from the water phase is based on the strong bonding tendency of TBT to organic matter. In this way, TBT can be bound to the organic matter of activated sludge, during the mixing step (by aeration) of wastewater and sludge. In a second step, the settling step, the TBT-loaded sludge is removed from the treated water.

2.5.2.2. Technical execution (Fent, 1996)

This process occurs in classical wastewater treatment plants. Fent reports about the Zürich wastewater treatment plant, in which TBT was removed with a high efficiency from the water phase, but where almost all of this pollutant was accumulated in the sewage sludge. The contaminated sludge was treated afterwards at various conditions, including both aerobic and anaerobic, mesophilic and thermophilic. At all conditions, TBT-degradation did not surpass 30%.

An overview of the results is given in Table 6 below. The numbers for sludge concern concentrations after digestion of the fresh sewage sludge.

Status of water or sludge	MBT ($\mu\text{g/l}$ or $\mu\text{g/kg DW}$)	DBT ($\mu\text{g/l}$ or $\mu\text{g/kg DW}$)	TBT ($\mu\text{g/l}$ or $\mu\text{g/kg DW}$)	Elimination
Raw wastewater	0,181	0,456	0,175	
Primary effluent	0,069	0,092	0,059	73%
Secondary effl.	0,030	0,028	0,021	90%
Tertiary effluent	0,009	0,006	0,002	98%
Digested sludge	800	1000	1000	

Table 6: Average concentrations of organotins in wastewater, at different stages of treatment, and in digested sludge

Concerning the accumulation and metabolism of TBT by living microorganisms, it was found by Tam et al., 2002 that the accumulation of TBT is more efficient by dead microalgal cells than by living species, during a 3 day exposure. On the long term (14 days) however, it appeared that the sum of accumulation and metabolism by living microalgae was similar to single accumulation by dead cells: 85% by *Chlorella* species, and 90% by *Scenedesmus*. The highest specific TBT uptake values, as well as the highest degradation, were recorded in *Chlorella miniata*.

This confirms that organic material, dead or alive, has a very important role in accumulation of TBT.

Furthermore, the degradation process is strongly influenced by temperature and by light, pointing to the role of photosynthetic organisms.

2.5.3. Removal by means of activated carbon

2.5.3.1. Theoretical background

Because TBT is highly attracted to particles in water, adsorption process may prove to be the most effective means to reduce TBT-concentration.

Activated carbon is a material that adsorbs organic matter very well, and, consequently, it also adsorbs TBT very efficiently. Under certain conditions, TBT-removal efficiencies up to 99,99% can be reached. (Fox et al. 1999, see also Annex 6)^[A50]

A necessary step prior to activated carbon filtration is the removal of all particulate and organic material from the wastewater. Otherwise carbon would adsorb all organic material presented to it, and its adsorption capacity for TBT would be reduced.

2.5.3.2. Technical execution (Fox et al. 1999)^[A51]

In 1997, the Norfolk Shipbuilding and Drydock Corporation (NORSHIPCO), a member of the Center for Advanced Ship Repair and Maintenance (CASRM), which is a consortium that coordinates most of the shipyards TBT research, development and demonstration projects, has built a pilot plant for TBT-removal from shipyards wash down wastewater.

The treatment chain consisted of a DAF (dissolved air flotation) unit (with addition of coagulants and flocculants) for removal of particulate TBT, followed by a sand filter, in which fine particles were removed. Finally there was a two-stage activated carbon filter to remove dissolved TBT.

A flow diagram is presented in Figure 6

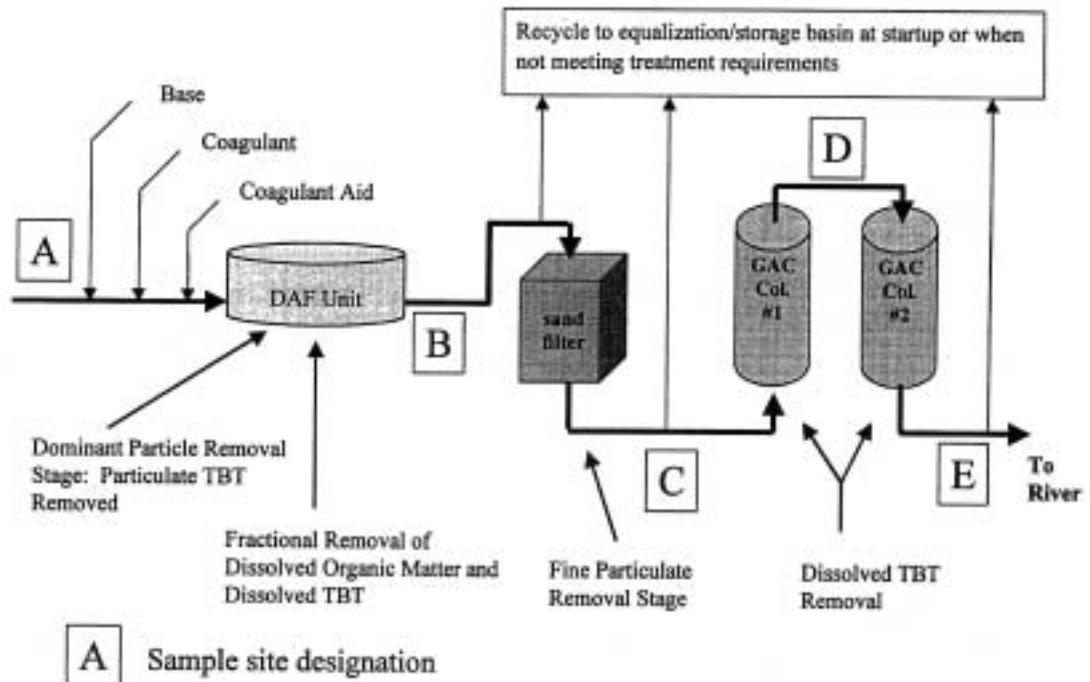

Figure 6: Flow sheet of a TBT removal installation by flotation (DAF) and active carbon (GAC)

The equipment used in these studies was not optimized: the pilot plant was built with “off-the-shelf” technology. The DAF-unit, for example, was operated at a flow that was more than twice the designed capacity. Moreover, the equipment was not always used in a proper way to facilitate optimal working conditions.

Nevertheless, the results of treatment were sometimes very promising. On one occasion the influent water had a TBT-concentration of 485.000 ng/l, and the effluent from the activated carbon filter reached 41 ng/l.

This means that it is possible to reach the goal of 50 ng/l (the Virginia (USA) discharge limit for TBT in surface water.

It has also been proven that the key to effective TBT-removal by activated carbon is the effective removal of suspended solids by earlier stages, i.e. the DAF unit with addition of coagulants and flocculants.

After these sub-optimal trials, NORSHIPCO has constructed a full scale, fully engineered version of this system.

The carbon bed was sized to achieve a water-carbon contact time of over twenty-five minutes at full flow.

Unfortunately, results of these experiments were not yet available at the moment of redaction of the referred article.

2.5.4. Solvent extraction of TBT (Ashcroft and Abel, 1999)^[A53]

2.5.4.1. Theoretical background

Since tributyltin is a weakly or non-polar organic substance, with a strong tendency to adsorb to non-polar matter, such as solvents, it can be removed from the water phase by solvent extraction.

The extraction process is carried out by dispersion of an appropriate solvent in the process water stream. The dispersion provides an environment for mass transfer of the TBT-molecules into the solvent.

To achieve this goal the solvent is dispersed into the water to form a high surface area. This enables mass transfer from water to solvent.

Once the extraction process is complete, a phase separation is realised between the water and the solvent phase. This happens in a decantor. The polluted solvent stream is treated in order to be recycled in the extraction process.

2.5.4.2. Technical execution

A flow sheet of a single-stage extraction equipment is shown in Figure 7:

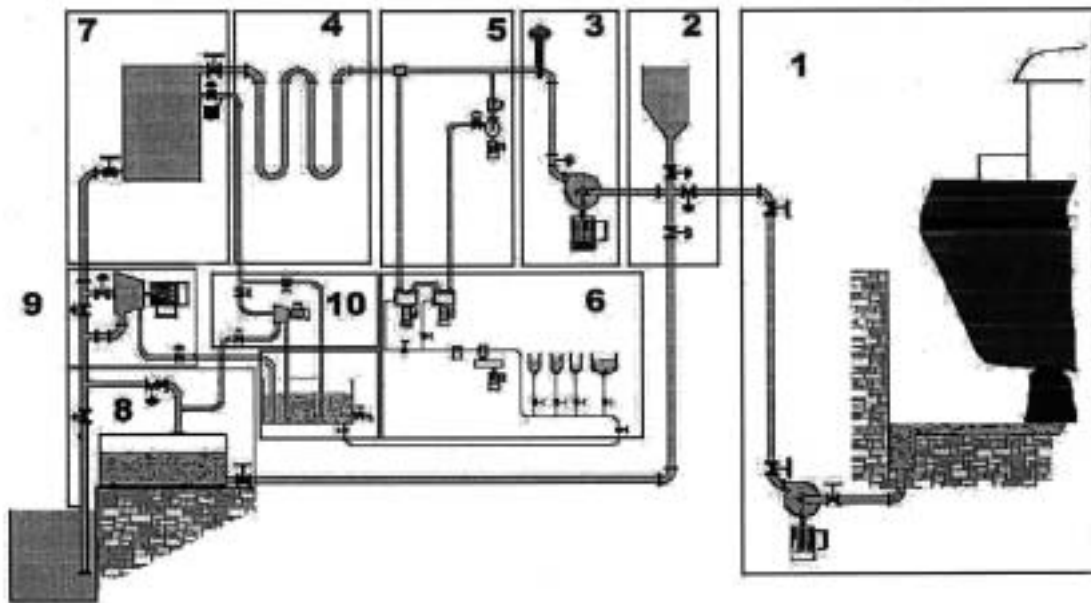

Figure 7: Flow sheet of an installation for TBT removal by solvent extraction

In a first step (1) a transfer pump will take the wash down wastewater and inject into the system. This step includes a primary screening to remove solids etc.

The front end of the process unit has a reservoir to allow priming of the system prior to initiating treatment. This primary fluid stream will then be pumped (3) to the “reactor pipe work” (4).

A controlled fraction of the main flow is diverted (5) to the dosing system (6). In this module, a concentrate is made with the extraction solvent being dispersed in the process liquid.

The reaction module (4) is made in a way that it keeps the extraction solvent in suspension.

The treated mixture then enters the separation module (7) where the solvent and the cleaned water streams are separated. The water can go for discharge (8) or further treatment (9) according to local quality standards. The solvent stream is collected (10) for reuse, treatment or disposal.

The technology has been applied in a 10 tonnes /hour equipment, and has proven to reduce –in one pass- TBT levels from 2 mg/l to 200 ng/l.

Further, the main advantages are the minimisation of waste volume, and the fact that no solid waste is produced. In fact the solvent volume required is not exceeding 2 to 4 % of the process mass.

3. CONCLUSIONS

As a conclusion, an schematic overview is presented of the different technologies for sludge respectively water treatment, encountered in literature. In these diagrams the following aspects are discussed:

- Availability, i.e. does the technology exist only on laboratory or pilot scale, or is it already tested on full scale?
- Efficiency, expressed as tributyltin removal efficiency percentage
- Degradation speed, expressed as half life.
- Cost, i.e. investment and operational cost, as far as available from literature; otherwise, a qualitative interpretation will be given.
- A listing of the most important advantages (PRO) and disadvantages (CONTRA)

3.1. Overview of sludge treatment technologies

CRITERION	LAND DISPOSAL (anaerobic)	LAND DISPOSAL (aerobic, 5°C)	LAND DISPOSAL (aerobic, 55°C)	EVAPORATION (> 170°C)	PRESSURE THERMOLYSIS (230°C; 2h)	ELECTRO-CHEMICAL OXIDATION (leaching + electrolysis)	ELECTRO-CHEMICAL OXIDATION (direct electrolysis)	BIO- & PHYTO-REMEDICATION
AVAILABILITY	Full-scale	Laboratory scale	Laboratory scale	None	Pilot-scale	Laboratory scale	Full-scale	None
REMOVAL EFFICIENCY(%)				To be proved	100 %	67 %	99,0 %	
HALF-LIFE (days)	1800	560 - 630	30-50					30
COST (€/tonne)	Very low	Low	High (energy)	Intermediate	11,5 - 15		15	Low
PRO	Simple	Simple	Relatively fast	Built with existing technologies	Fast High efficiency		High efficiency PAH are co-degraded	Simple
CONTRA	Slow Applicable only on moderately contaminated sludge	Un-structured mud needs to be restacked Applicable only on moderately contaminated sludge	Energy cost Applicable only on moderately contaminated sludge	Energy cost	Energy cost (140 kWh/ton)	Un-efficient	Difficult debutylation MBT → Sn	Inoculation and nutrient addition needed

3.2. Overview of water treatment technologies

CRITERION	UV-OXIDATION	ACTIVATED SLUDGE	ACTIVATED CARBON	SOLVENT EXTRACTION
AVAILABILITY	Full-scale	Full-scale	Full-scale	Full-scale
REMOVAL EFFICIENCY(%)	99,9%	90 (secondary treatment) – 98 (tertiary treatment)	99,9 %	99,9 %
HALF-LIFE (minutes)	0,37			
COST (€/tonne)	High (energy +H ₂ O ₂)	Low	High (activated carbon)	< 7
PRO	High efficiency Fast	Simple	High efficiency Fast	High efficiency Low solvent need Low waste volume
CONTRA	Oxidant needed in large quantities Negative influence from turbidity and organic matter	Production of high volumes of contaminated sludge	Removal of suspended solids needed in preliminary step (e.g. DAF) Need for a posteriori treatment of TBT-contaminated activated carbon	

4. SUGGESTIONS FOR FURTHER INVESTIGATIONS

4.1. Sludge treatment technologies

Taking into account the aspects “efficiency”, “speed”, “cost” and “PRO-CONTRA-points” in the table of paragraph 3.1, and arranging them in decreasing order of availability, the following technologies can be considered for further investigation on the removal of TBT from sediment or dredging sludge:

- electro-chemical oxidation by direct electrolysis;
- thermal treatment by pressure thermolysis;
- disposal on land in aerobic and thermophilic (55°C) conditions;
- thermal treatment by evaporation;
- bio- and phyto-remediation.

Electrochemical oxidation has been tested on full scale. TBT-removal efficiency is up to 99% or higher, the degradation process is running quickly (a few hours) and the cost is equal to or lower than 15€/tonne. There is no direct need for further investigation.

Pressure thermolysis has been tested only on pilot scale. TBT-removal efficiency is up to 100%, the degradation process is running quickly (2 hours) and the cost has been calculated to be between 11,5 and 15€/tonne. It would be interesting to do an exhaustive test on full scale.

Disposal on land in aerobic and thermophilic (55°C) conditions has been tested on laboratory scale only. It would be interesting to perform a pilot scale test in order to gather more data on removal efficiency, cost and PRO's and CONTRA's.

Thermal treatment by evaporation, and bio- and phyto-remediation are technologies that are known from treatment of other pollutants. It would be interesting to test -on laboratory or pilot scale- the applicability on the removal of TBT.

Next to these technologies, that are specifically designed for TBT-removal, a technology can be tested that originally is made for sludge dewatering, but that seems to have TBT-removal as a secondary effect: mechanical dewatering of dredging sludge with addition of calcium hydroxide or other pH-raising chemicals. Indeed, pH-raising increases both the solubility in water and the degradation speed of TBT. In that way, TBT can be transferred from the solid to the liquid phase. In the liquid phase it can easily and quickly be degraded.

4.2. Water treatment technologies

Taking into account the aspects “efficiency”, “speed”, “cost” and “PRO-CONTRA-points” in the table of paragraph 3.2, and arranging them in decreasing order of availability, the following technologies can be considered for further investigation on the removal of TBT from surface water:

- UV-oxidation;
- solvent extraction.

Both of the technologies have been tested on full scale, the TBT-removal efficiency is up to 99,9%, the degradation process is running quickly (a few hours) and the cost might be lower than 7€/m³. There is no direct need for further investigation on these water-treatment technologies.

5. REFERENCES

- * Ad-hoc working group of the Flemish Ministries of Mobility and of Agriculture on Organotin compounds: *Organotinverbindingen, een mogelijke aanpak*, note, 25/09/2001
- * AMERON: *ABC#3 marine news*, www.abc-3.com, april 2002
- * Ashcroft P.L., Abel D.: Process Water Treatment for the removal of TBT in ship wash down wastewaters, *Proceedings of Oceans '99 Congress*, p.73 – 75
- * Brandsch R., Nowak K.E., Binder N., Jastorff B.: *Investigations concerning the sustainability of remediation by land deposition of tributyltin contaminated harbour sediments*, *J Soils & Sediments* 1(4) 234-236, 2001
- * Champ, M.A.: *The status of the treaty to ban TBT in marine antifouling paints and alternatives*, *Proceedings of 24th UJNR Marine Facilities Panel Meeting in Hawaii*, November 2001
- * Champ, M.A.: *The new IMO treaty to ban TBT*, *Maritime Reporter and Engineering News*, December 2002
- * Daehne B., Watermann B., Haase M., Michaelis H., Isensee J. Jakobs R.: *Alternativen zu TBT*, june 2000
- * Extension Toxicology Network – Pesticide information profiles: tributyltin, <http://ace.ace.orst.edu>
- * European Commission, *Commission Decision concerning the draft national provisions notified by the Kingdom of Belgium concerning the limitations of the marketing and use of organostannic compounds*, C(2000) 2016, 25/07/2000
- * Fent K. *Ecotoxicology of organotin compounds*, *Critical Reviews in Toxicology*, vol 26 (1), p.1-117, january 1996
- * Fent K, *Organotin compounds in municipal wastewater and sewage sludge: contamination, fate in treatment process and ecotoxicological consequences*, *The Science of the Total Environment* 185 (1996) 151-159
- * Fletcher L.E., Lewis J.A.: *Regulation of shipyard discharges in Australia and the potential of UV oxidation for TBT degradation in washdown waste water*, *Proceedings of Oceans '99 Congress*, p. 27 - 35
- * Fox T.J., Beacham T., Schafran G.C., Champ M.A.: *Advanced technologies for removing TBT from ship washdown and drydock runoff wastewaters*, *Proceedings of Oceans '99 Congress*, p.63-71
- * Harino, H., et al., *Susceptibility of bacterial populations to organotin compounds and microbial degradation of organotin compounds in environmental water. Environmental Pollution*, 1997. **98**(2): p. 157-162.
- * Harino, H., et al., *Degradation of the tributyltin compounds by the microorganisms in water and sediment collected from the harbour area of Osaka City, Japan. Environmental Pollution*, 1997. **98**(2): p. 163-167.
- * Hunter J.E. & Anderson C.D.: *Antifouling Paints and the Environment*, www.anchorpublishing.com, 2002
- * Inoue, H., et al., *Degradation of triphenyltin by a fluorescent pseudomonad. Applied and Environmental Microbiology*, 2000. **66**(8): p. 3492-3498.
- * Inoue, H., et al., *Tin-carbon cleavage of organotin compounds by pyoverdine from Pseudomonas chlororaphis. Applied and Environmental Microbiology*, 2003. **69**(2): p. 878-883.
- * JOTUN: *Key issues in IMO's antifouling convention*, www.jotun.com, 2002

- * Kawai, S., et al., *Degradation of tributyltin by a bacterial strain isolated from polluted river water*, *Environmental Pollution*, 1998. **102**(2-3): p. 259-263.
- * Linley-Adams G.: *The accumulation and impact of organotins on the marine biota within the Mediterranean region*, WWF-UK, march 1999.
- * Mostofizadeh Ch.: *Elimination of TBT compounds from dredged material by means of pressure thermolysis*, Institute of Energy and Process Technology (IEV), Bremerhaven, 2001
- * Mink F.J.: *The application of the Precautionary Principle to the disposal of dredged material contaminated with TBT*, publication of European Dredging Association, 2000
- * Paint & Coatings Industry: Jotun launches Tin-free antifouling system, www.pcimag.com, January 2000
- * Organotin Environmental Program (ORTEPA): *Antifoulants: Background – Regulations – Environmental research – Performance Cost*, www.ortepa.org, 2002
- * ORTEPA: *TBT-antifouling paints versus TBT-free technologies*, www.ortepa.org, 2002
- * Platz N. et al.: *Constructing a pilot-unit to minimise the organic tin compound and heavy metal contamination of dock waste water. (LIFE99 ENV/D/000414)*, www.europa.eu.int/comm/environment/life/
- * Reed J., Waldock M.J., Jones B., Blake S., Roberts P., Jones G., Elverson C., Hall S., Murray L.: *Remediation techniques applied to reduce paint-derived tributyltin in dredged material*, Physical – Chemical Remediation, 2002 (?)
- * Sectorstar: EPA approval of TBT-free Antifoulant Coatings, www.sectorstar.org, 2002
- * SIGMA: *Launch of Sigma Alphatrim; the new generation antifouling*, www.ship-technology.com, august 2002
- * Stichnothe H., Thöming J., Calmano W.: *Detoxification of tributyltin contaminated sediments by an electro-chemical process*, *The science of the total environment* 266, p. 265-271, 2001
- * Stichnothe H., Keller A., Thöming J., Lohmann N., Calmano W.: *Reduction of tributyltin and other organic pollutants of concern in contaminated sediments by means of an electrochemical oxidation*, *Acta hydrochim. Hydrobiol.* 30 (2002)2-3, p87 – 93
- * Stichnothe H., Telephone call dd. 12/02/03
- * Swain G., *Redefining antifouling coatings*, JPCL – PMC, September 1999
- * Tam N.F.Y., Chong A.M.Y., Wong Y.S.: *Removal of tributyltin by live and dead microalgal cells*, *Marine Pollution Bulletin* 45 (2002) 362-371
- * The Baltic Asia-Pacific Shipping: *Paints and the environment*, www.stroudgate.net, 2002
- * Uhler A.D., Stout S.A., McCarthy K.J., Emsbo-Mattingly S.D.: *Tributyltin: a unique sediment contaminant*, *Soil Sediment and Groundwater*, june 2000
- * Watermann B., Daehne B., Michaelis H., Sievers S., Dannenberg R., Wiegemann M.: *Performance of biocide-free antifouling paints, Summary of Vol.1: Application of test paints and inspections of 2000*, WWF Deutschland, 2001
- * WWF: *IMO Anti-fouling convention: TBT alternatives*, www.panda.org, 2002
- * www.blohmvooss.com

Annex 1 **Reed J., Waldock M.J., Jones B., Blake S., Roberts P., Jones G.,
Elverson C., Hall S., Murray L.:**
*Remediation techniques applied to reduce paint-derived tributyltin in
dredged material,*
Physical – Chemical Remediation, 2002

REMEDICATION TECHNIQUES APPLIED TO REDUCE PAINT-DERIVED TRIBUTYLTIN (TBT) IN DREDGED MATERIAL

Jacque Reed (CEFAS, UK), Mike J. Waldock (CEFAS, UK), Bryn Jones (CEFAS, UK), Sylvia Blake (CEFAS, UK), Paul Roberts (CEFAS, UK), Gary Jones (CEFAS, UK), Chris Elverson (University of Nottingham, UK), Steve Hall (University of Nottingham, UK) and *Lindsay Murray* (CEFAS, UK).

ABSTRACT: Since the ban on tributyltin (TBT) for small vessels (<25m) in the UK, there has been a general decrease in TBT concentrations at most impacted sites. However, a historic legacy of TBT contamination remains at a number of locations around the UK. Today paint-derived TBT in harbour sediments provides an ongoing source of contamination. DEFRA as the regulatory authority for sea disposal of dredged material in England and Wales has funded CEFAS to investigate the distribution of TBT as sediment-entrained paint particles and initiated research to develop remediation methods to mitigate environmental harm. The aim of this study is to remediate sediments to increase the amount of the sediment that is available for conventional disposal whilst the isolated contaminated material can either be subjected to further remediation (i.e., biological or chemical methods), sent to landfill or placed in a contained site. The study has focused on rapid methods for remediation and a number of different physical and chemical separation techniques have been evaluated. Experiments have been conducted on sediments spiked at two concentrations (1 and 10 mg kg⁻¹) of TBT paint particles and samples taken from contaminated environments (4 mg kg⁻¹ TBT). Preliminary results are encouraging and it has proven possible to isolate a heavily contaminated component of the sediment leading to a significant reduction in the volume of grossly contaminated material. Samples were fractionated by size and density using froth flotation and density separation techniques and it was possible to identify paint particles in the large/light samples (250 - 500 μ m). The results generally show that the highest concentrations of TBT (i.e., paint particles) are associated with the light fractions. Initial results suggest that it may be possible to enhance isolation of contaminated material by these two techniques. Further method development is ongoing to increase the proportion of TBT-enhanced material removed from the bulk sediment.

INTRODUCTION

Despite the huge amount of research and monitoring that has been carried out during the last 20 years there are still gaps in our knowledge when addressing the issue of the environmental harm of waste paint material entrained in dockyard sediments. TBT occurs in these sediments in three broad categories (i) large paint chippings (ii) small paint particles derived from high pressure hosing of copolymer formulations and (iii) TBT adsorbed to the sediments. Coastal sediments, in particular sediments present in ports and harbours, are contaminated to some degree with TBT from the legacy of use during the last 30 years in vessel antifoul-

ing paints. Perhaps the most persistent form of TBT is paint-derived material in dock and harbour sediments.

Currently, there are no proven remediation techniques aimed specifically at TBT contamination. To address this issue, a study was commissioned by DEFRA, the licensing authority, to investigate sediment-TBT contamination in England and Wales, and develop a suitable methodology to remove paint-derived TBT from dockyard material. To reduce the impact of TBT from paint particles when dockyard sediments are disposed offshore, investigations have been carried out on physical and chemical remediation techniques.

Aims. The aims of this study are: (i) to review historic trends in TBT concentrations in dredged material to identify impacted sites around England and Wales and list sites of priority concern; (ii) to determine the behaviour of TBT-contaminated sediment at dredged material disposal sites and (iii) to evaluate whether or not TBT impacted sediments may be improved by remediation techniques before disposal.

HISTORIC LEGACY OF TBT—THE PROBLEM IN ENGLAND AND WALES

Most estuarine sediments in England and Wales are contaminated to some degree compared to offshore sediments. TBT concentrations in dredged material have been measured routinely by CEFAS since 1992 and a total of 1507 locations have been sampled. Sediments at many of these locations (49%) are regarded as suitable for sea disposal. A further 39% of locations have required further investigation to determine the local spatial extent of TBT contamination and additional restrictions have been imposed (e.g. rejection of specific sites within the location) before a licence is approved for sea disposal. Material at the remaining 12% of locations were regarded as unsuitable for sea disposal. Table 1 shows mean annual TBT concentrations (mg/kg) from selected sites in England and Wales.

TABLE 1. A range of TBT concentrations (mg/kg) at sites around England and Wales.

Year	Tyne	Mersey	Falmouth	Thames	Solent
1992	3.02				
1993	0.14 - 1.3		34.88	0.06	0.05 - 0.38
1994	0.13	0.21 - 2.06	15.38		0.13 - 0.48
1995	0.01 - 1.7	0.14 - 8.84		0.15	0.01 - 0.66
1996	0.55 - 8.24	0.15 - 0.44		0.26	0.01 - 0.44
1997	4.47 - 65.25	0.01 - 2.45			0.3 - 0.99
1998	0.02 - 24	0.25		0.17	0.05 - 0.24
1999	0.002 - 119	0.01 - 0.22			0.03 - 32.7
2000	0.14 - 8.16	0.01 - 2.7		0.01 - 0.127	0.05 - 1.41

Sediments considered to be grossly contaminated with TBT concentrations (>1 mg/kg) are located close to dockyards at Falmouth, River Mersey, River Tyne, River Orwell, River Humber and Swansea. At several locations sediments

are suspected to contain paint chippings due to excessive TBT concentrations (up to 100 mg/kg). Consequently, alternative measures are here sought to assist dock owners and port authorities in managing the paint-derived TBT problem.

TBT AT OFFSHORE DREDGED MATERIAL DISPOSAL GROUNDS

Since gross contamination is patchy when waste paint material is entrained in dockyard sediments, concerns were raised about missing hot-spots when few samples are analysed as part of the risk assessment. There is therefore the potential for redistributing TBT in dredged material at the disposal grounds.

Surveys were conducted to investigate whether TBT concentrations were a problem offshore at selected dredged material disposal grounds. Sediment cores were taken at several sites at each of the disposal grounds (total samples collected $n=30$). As predicted from risk assessments, TBT concentrations were low at all disposal grounds except at one location in the North East of England (Figure 1). Within and outside of this site TBT profiles (TBT:DBT ratios) were determined and even here sites outside the disposal ground showed TBT values (although at relatively low concentrations). A decrease of TBT concentrations with depth has been shown which indicates degradation of TBT. Recent restrictions on disposal at this site will eventually ameliorate the present situation.

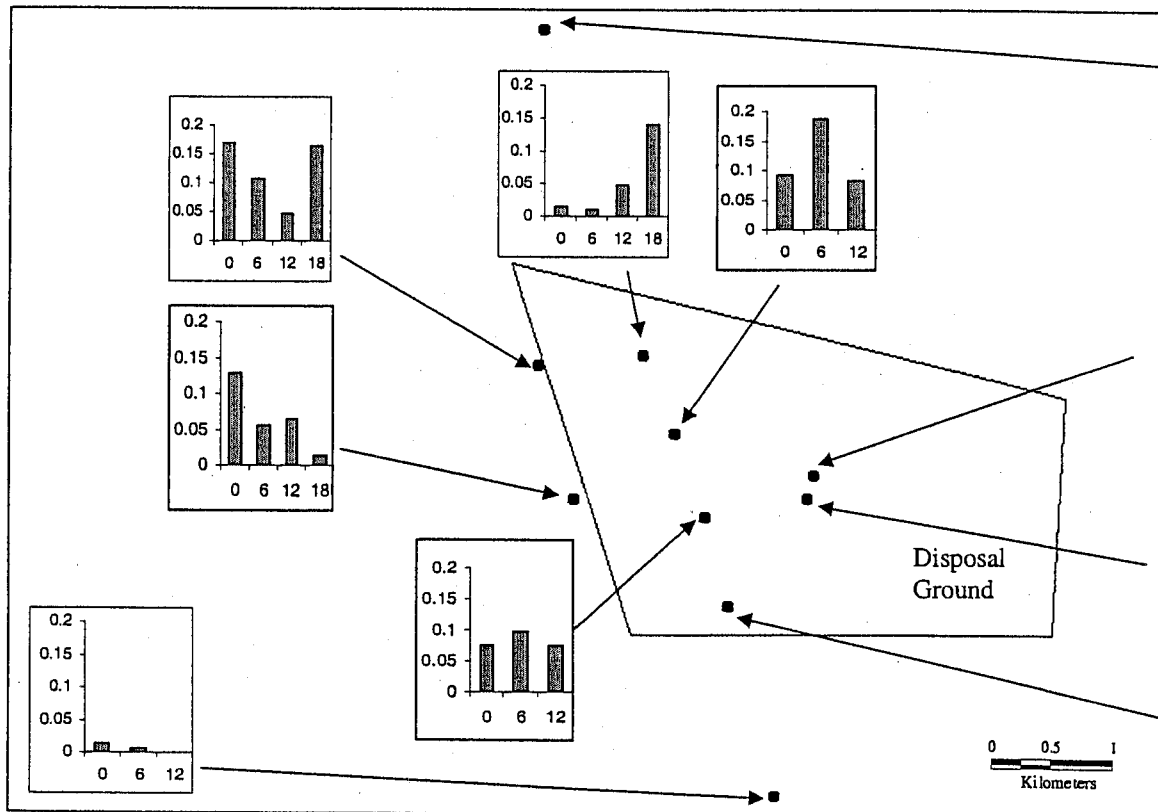

FIGURE 1. TBT concentrations (mg/kg d/w) in sediment cores (cm) at a disposal ground in North East England.

REMEDICATION TECHNIQUES FOR TBT CONTAMINATION

There are several techniques that have been identified for the remediation of TBT from contaminated sediments. These have utilised biodegradation, electrochemistry, physical separation, thermal and chemical extraction processes. Various recoveries have been obtained, but the most successful is up to 80% removal (De Brabandere *et al.*, 1997). Our study concentrates on low-cost rapid solutions based on physico/chemical approaches.

Grossly contaminated dredged material was collected using a Van veen grab and analysed for TBT. Since TBT is highly toxic to aquatic organisms, methods of analysis must be adequate for the determination of trace quantities (nanograms per gram) of analyte. Organotin compounds are therefore extracted from dredged material by sodium hydroxide and methanol, converted to hydrides and partitioned into hexane. The derivatives are then analysed by gas chromatography with flame photometric detection (GC-FPD) (Waldock *et al.* 1989). The detection limit for the method is 0.005 $\mu\text{g/g}$ for TBT, 0.010 $\mu\text{g/g}$ for DBT and 0.02 $\mu\text{g/g}$ for MBT.

A subsample of contaminated dock sediment was separated into fractions of different densities and particle sizes using different physical separation techniques to aid in the remediation of contaminated substrates. These included: hydrocycloning; in which a series of hydrocyclones are used to separate increasingly fine fractions of sediment down to $\sim 5 \mu\text{m}$ (the subsequent fractions are collected and analysed for TBT); and froth flotation, which requires the addition of chemical agents and air to the sediment sample. The choice of chemical depends on the target contaminant. A knowledge of the properties of TBT containing paint flakes was useful in determining the additives.

In addition, sediments have also been prepared for laboratory tests using TBT copolymer paint particles at two concentrations (1.0 and 10 mg kg^{-1}). Paint residues used to spike these sediments were ground to size $< 63 \mu\text{m}$ to mimic slurry from shipyard practices. Similar physical and chemical separation methods above were applied to these spiked sediments to investigate the size fraction where TBT paint became enriched.

RESULTS AND DISCUSSION

TBT enriched samples were identified using analytical methods above and additional isolation of TBT-based paint particles was accomplished using surrogate markers for paint by elemental probe electron microscopy (Figure 2).

Dredged sediments were subjected to two processes to separate the material into fractions by particle size and density. TBT was analysed in different size fractions (Table 2). It was possible to visually identify paint particles in the float sample and the middle fraction (250 - 500 μm) using the froth flotation and density separation techniques, respectively. The results generally show that the highest concentrations of TBT (i.e., paint particles) are associated with the light fractions. This is evident from the field sediment sample. Here, elevated TBT levels within the light fraction were mainly confined to the $> 63 \mu\text{m}$ size fraction. This suggests that Tyne sediments contain larger paint particles than previously suspected. It was possible to identify paint particles in the "large light" fractions

(Figure 3). Results from the spiked sediments suggested that the remediation of the sediments containing paint particles $<63 \mu\text{m}$ shows the reverse contamination pattern (Table 3 and 4). Importantly, paint particles used to spike these sediments were pre-treated to $< 63 \mu\text{m}$ size. This may explain the different contamination patterns shown.

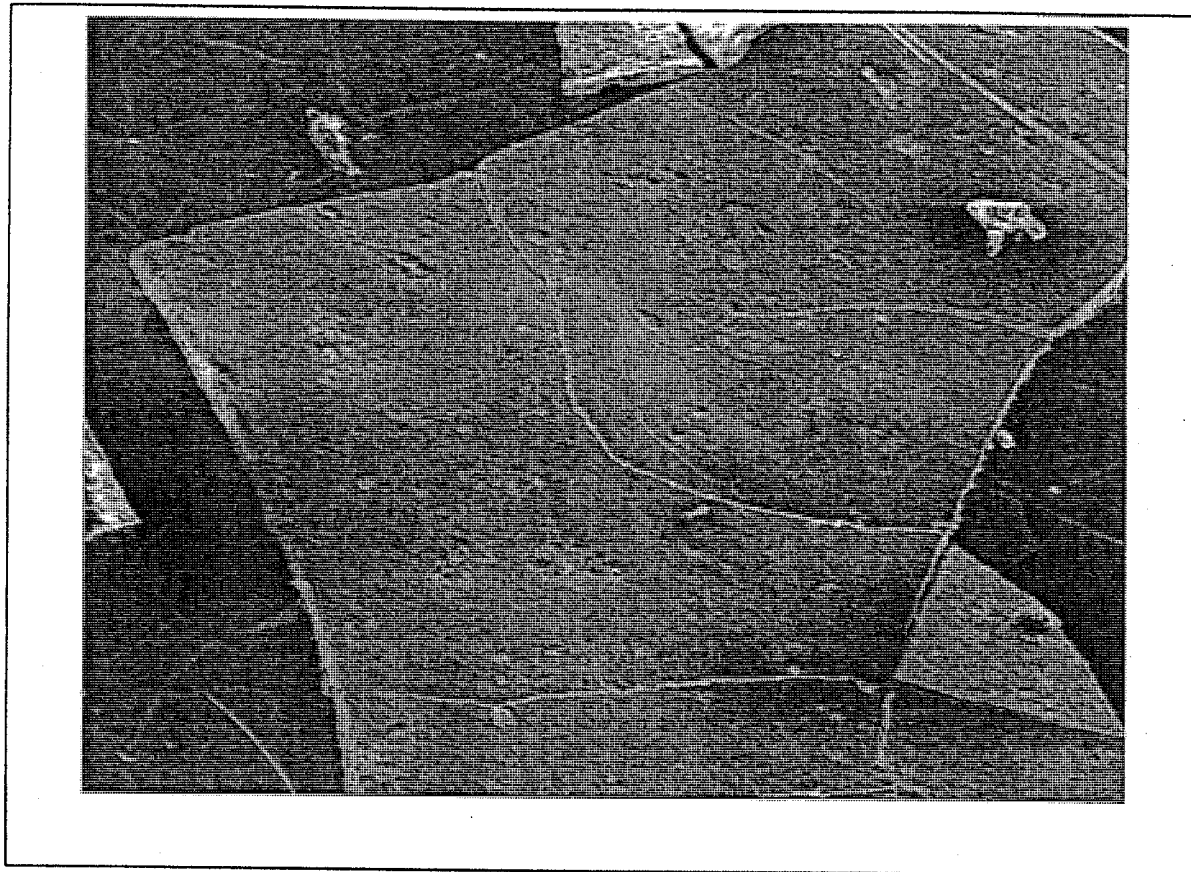

FIGURE 2. Large paint flake identified using electron microscopy.

The most encouraging result from these separation processes is that it has proven possible to isolate a heavily contaminated component of the sediment leading to a marked reduction in the volume of the contaminated sample (60-70%). The aim here is to increase the bulk of the sediment that is then available for conventional disposal or use whilst the isolated contaminated material can possibly be subjected to further remediation (i.e., biological or chemical), sent to landfill or placed in a contained site. Initial results suggest that it may be possible to remove a greater percentage of TBT from dredged material using variants of these techniques.

Further method development is required to increase the proportion of TBT-enhanced material removed from the sediment. A second series of trials is in hand to optimise the fractionation procedure.

CONCLUSIONS

Elevated concentrations of TBT ($> 1 \text{ mg/kg}$) are common in UK dockyards and sediments at many sites contain particulate paint material. TBT at these concentrations are perceived to originate from shipyard practices in the past.

TABLE 2. TBT concentrations in fractions of dredged material from the River Tyne.

density	Size →				
	38 μ m	63 μ m	125 μ m	250 μ m	500 μ m
light	0.73	0.97	3.25	11.48	8.1
medium	0.44	0.22	2.05	1.85	4.01
heavy	0.21	0.32	0.2	1.84	3.46

The original sample contained a mean concentration of 4 mg/kg (shaded values are higher than those likely to be given approval for disposal to sea). The total mass of sample in the shaded region was above 60% in this trial, but the ability to discriminate heavily and less heavily contaminated material provides a promising way forward for further work.

TABLE 3. TBT concentrations in TBT spiked sediment (<63 μ m) (1 mg kg⁻¹)

density	Size →				
	38 μ m	63 μ m	125 μ m	250 μ m	500 μ m
light	9.05	1.03	1.22	1	0.1
medium	4.93	1.85	1.79	0.93	
heavy	0.96	1.14	0.33	0.378	0.06

TABLE 4. TBT concentrations in TBT spiked sediment (<63 μ m) (10 mg kg⁻¹)

density	Size →				
	38 μ m	63 μ m	125 μ m	250 μ m	500 μ m
light	56.91	24.82	11.45	10.44	1.51
medium	21.92	19.92	1.1	5.71	0.12
heavy	6.09	3.07	0.33	5.9	0.13

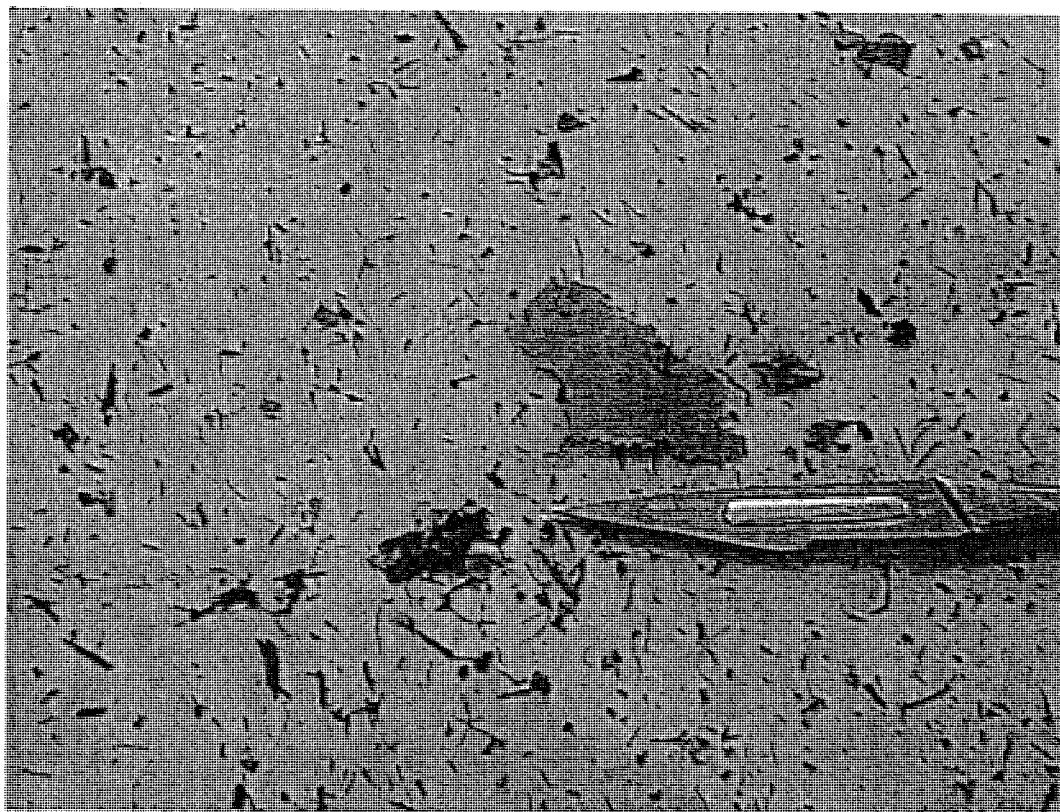

FIGURE 3. A paint flake from the TBT-enhanced sediment fraction using a density separation technique.

Recent surveys of offshore dredge disposal sites show that current restrictions on disposal of such sediments are sufficient to contain any impact within disposal sites. However, it is vital to at least maintain the level of commitment to monitoring that is undertaken at selected disposal grounds to confirm this situation.

The pilot studies utilising TBT-contaminated sediments have identified techniques that provide a promising way forward in removing particulate TBT contamination. A combination of froth flotation and density separation techniques have been effective in reducing >60 percent of paint derived TBT. Further method development is required to increase the proportion of TBT-enhanced material. Accordingly, further samples will need to be analysed so that these results can be validated.

FUTURE WORK

Further optimisation of these methods are required to increase the percentage of TBT from the remediated sediment. Subsequent development requires a large scale experiment to be conducted. In addition, an experimental study should be conducted to investigate the behaviour of paint particles in sediments and studies on the bioavailability of sediment-entrained paint material should also be investigated (Reed *et al.*, 2001).

The authors would like to thank DEFRA, UK for funding this project.

REFERENCES

De Brabandere J., Vanderhaegen B., Dumon G. & Verstraete W. 1997. Bioremediation of Contaminated Harbour Sediment: Development of a Treatment Assessment Strategy. Proc. International Conference on Contaminated Sediments (ICCS), Rotterdam, 1997. Vol 1: 342-345

Reed, J., Thain, J.E., Jones, C., Blake, S.J., James, S., & Waldock, M.J. 2001. Behaviour, fate and bioavailability of paint-derived TBT in sediments. SETAC, Baltimore, November 2001.

Waldock, M.J., Waite, M.E. & Thain, J.E. 1989. The effect of the use of Tributyltin (TBT) antifoulings on aquatic ecosystems in the U.K. Report for Department of Environment.

Annex 2: **Brandsch R., Nowak K.E., Binder N., Jastorff B.:**
*Investigations concerning the sustainability of remediation by land
deposition of tributyltin contaminated harbour sediments,*
J Soils & Sediments 1(4) 234-236, 2001

Research Articles

Investigations Concerning the Sustainability of Remediation by Land Deposition of Tributyltin Contaminated Harbour Sediments

Extended Abstract *

Romana Brandsch^{1,2}, Karl-Ernst Nowak², Norbert Binder³, Bernd Jastorff¹

¹UFT-Zentrum für Umweltforschung und Umwelttechnologie, Universität Bremen, Leobener Straße, Postfach 330440, D-28359 Bremen, Germany

²Limnologisches Institut Dr. Nowak, Mayenbrook 1, D-28870 Ottersberg, Germany

³Hansestadt Bremisches Hafenamt, Elbinger Platz 1, D-27570 Bremerhaven, Germany

Corresponding author: Romana Brandsch; e-mail: rb@limnowak.com

Abstract. Sediments often contain high concentrations of tributyltin, which is used as a biocide in antifouling paints. The aim of our project was to assess land deposition as an alternative in dealing with TBT-contaminated harbour sediments. Therefore, we followed the biological degradation of TBT under aerobic and anaerobic conditions at different temperatures using defined laboratory experiments and performing field measurements. With the data obtained, a risk assessment is performed. The biological degradation of TBT is faster under aerobic conditions and with increasing temperature. The half-lives found show the dependency of the degradation rates on the temperature between 5 to 55°C. The degradation rate determined for water under the same conditions (just biological degradation, without photolysis) is almost 4 times higher than in the sediment. The field studies gave a degradation rate of around 10% per year in untreated sediment and 30% per year in restacked sediments. We did not observe any interference of released TBT with ground water or surrounding areas. The TBT uptake in plants was low.

Based on our results, a multidimensional risk evaluation was done, concerning the TBT and its degradation products dibutyltin (DBT) and monobutyltin (MBT) released from the deposition area. The land deposition appears to be a sustainable solution for dealing with TBT-contaminated harbour sediments. Compared to other disposals, it is economically one of the cheapest and, from an ecological point of view, it is acceptable.

Keywords: Biological degradation; biomonitoring; Dibutyltin (DBT); ecological research project Luneort; field studies; laboratory experiments; MBT; Monobutyltin (MBT); multidimensional risk analysis; sustainability; TBT; Tributyltin (TBT)

1 Background

To prevent fouling (algae, mussels), great ships are treated with antifouling-paints which act by continuously emitting small amounts of substances with biocidal action to the surrounding water. The most effective biocides appear to be

TBT-compounds (Goldberg 1986). Due to the continuous delivery of TBT to the water phase and because of its physical properties (strong adsorption to suspended material), great amounts of this compound were found in sediments of harbours and coastal regions (Fent and Muller 1991, Fent et al. 1991). Most harbours have to be dredged regularly to allow ships to pass. Thus, the problem of a disposal which is acceptable with respect to a minimum risk for humans and the environment arises.

The aim of a pilot study from the Hansestadt Bremisches Hafenamt (HBH) was to improve the biological degradation during land deposition using adequate methods. Our experiments were carried out with the aim to observe the biological degradation of TBT under aerobic and anaerobic conditions at different temperatures using defined laboratory experiments and performing field measurements. The information obtained should enable us to make a risk assessment regarding land deposition of TBT-contaminated sediments.

2 Laboratory Experiments

Two sediments from the harbour of Bremerhaven were chosen for measuring degradation kinetics (Sediment A with a TBT-content of 320 and Sediment B with 6600 µg/kg DW). These sediments were kept under defined and constant conditions and sampled regularly (Brandsch et al. 2001). The experiments with water were performed similarly, but only under aerobic conditions in the dark and between 5° and 45°C.

An exemplary graph for the decrease of the TBT concentration is shown for the aerobic Sediment A at different temperatures (Fig. 1). Table 1 shows the degradation rates of TBT and half-lives for sediments A and B respectively for water under aerobic conditions.

Assuming a first order reaction rate, the logarithm of concentration gives a linear dependency on time.

In cases where the sediments are kept under anaerobic conditions, the degradation rate is dramatically lower. Thus, it was not possible to calculate half-lives after 12 months.

* The full paper will be published in the January issue of UWSF – Z Umweltchem Ökotox 14 (1) 2002 (in German)

Table 1: Degradation rates of TBT and half-lives for sediments A and B, respectively for water under aerobic conditions

Temperature	k month ⁻¹			t _{1/2} month (weeks)		
	Sediment A 320 µg/kg DW	Sediment B 6600 µg/kg DW	water 750 ng/l	Sediment A 320 µg/kg DW	Sediment B 6600 µg/kg DW	water 750 ng/l
5°C	0.03	0.04	0.18	21 (90)	18 (78)	4 (17)
15°C	0.07	0.08	0.30	9 (40)	10 (43)	2 (10)
25°C	0.15	0.1	0.40	4 (19)	7 (30)	2 (7)
35°C	0.36	0.15	0.48	2 (9)	5 (20)	1 (6)
45°C	0.56	0.43	1.2	1 (5)	2 (7)	1 (2)
55°C	0.77	0.47		1 (4)	2 (7)	

Transformation factor month-week = 4.357

3 Field Studies

From September 1999 until April 2000 sediment with a medium content of 430 µg/kg DW was transferred through a pipeline from the harbour of Bremerhaven to an area to the west of the river Lune. The aim of the project was to observe and compare the degradation in sediments without any treatment (monitoring of depth profiles), with sediments being turned over regularly, and to measure the incorporation of TBT into plants.

Table 2 shows the concentrations measured as zero levels before the deposition began and during the period November 1999 till October 2000.

As soon as the deposition was finished and the sediment began to dry, we sampled three locations in the area and analysed the sediment in slices as a function of the depth. It turns out that the distribution is homogeneous in the whole area (horizontally as well as vertically) and that without any treatment, the TBT-content of the sediment decreases only 10% per year. The sedi-

ment which was restacked regularly (for a better access of air oxygen) shows a 30% decrease in TBT-concentration.

On the dry sediment, plants adapted to the high salinity began to grow very soon. The TBT-concentrations measured in the plants were low and ranged from <5 to 15 µg/kg DW.

4 Risk Assessment

Based on the presented results, it is now possible to make an evaluation of the risk referring to the areas next to the deposition, the life therein and to humans. Besides that, a comparison between TBT and its metabolites can be done. The model used describes the risk by means of the indicators: release rate, spatiotemporal range, bioaccumulation, biological activity and remaining uncertainty, which were introduced in the multidimensional assessment concept by Ranke and Jastorff (2000). For each indicator, the substances obtain a value between 1 (low risk potential) and 4 (high risk potential) and the result is shown in a grid diagram (Fig. 2).

Table 2: TBT, DBT and MBT-concentrations measured during the field studies

Measure point	Measure	Zero level (6 measurements)			Nov. 1999 – Oct. 2000 (20 measurements)		
		TBT	DBT	MBT	TBT	DBT	MBT
Soil	µg/kg DW	<1	7–36	1–18	–	–	–
Ground water	ng/l	<1–15	<1	<1	<1–5	<1–8	<1–8
Water from Lune	ng/l	5–6	5–6	5–13	<1–5	<1–16	3–49
Sediment Lune	µg/kg DW	23–75	3–9	5–10	14–78	3–20	2–9
Backtrack water	ng/l	–	–	–	4–73	2–16	5–68
Drain water	ng/l	–	–	–	<1–37	<1–63	<1–58

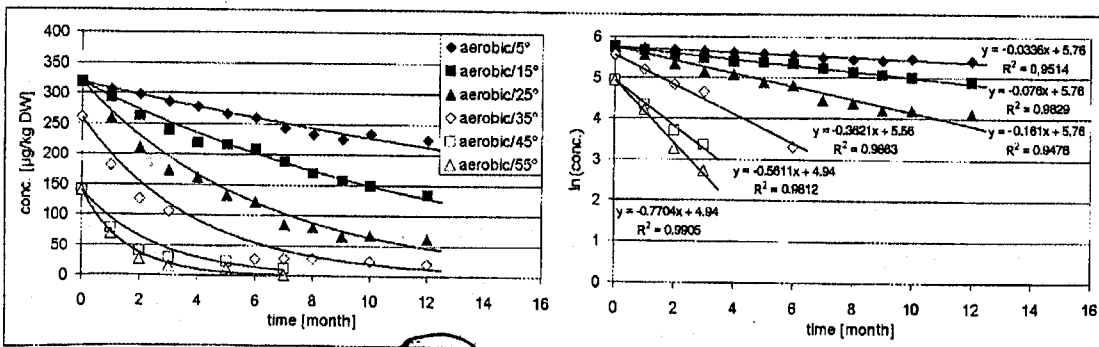

Fig. 1: Data of aerobic biological degradation for the Sediment A development of the TBT concentration and linearisation for the calculation of a half-life

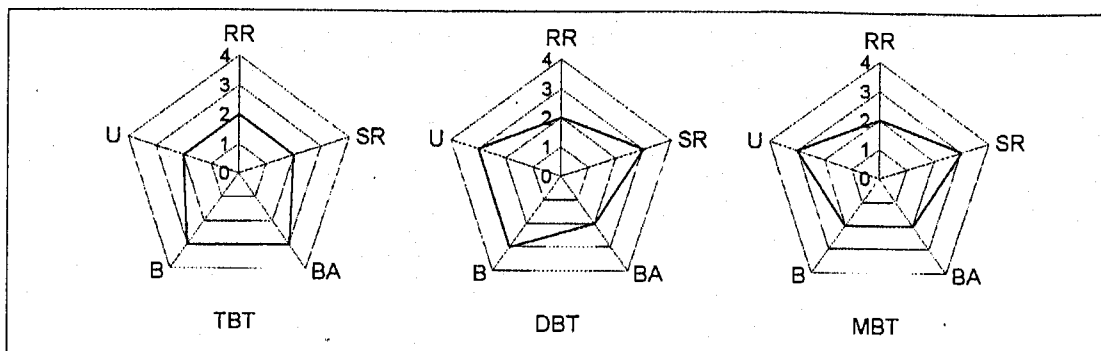

Fig. 2: Grid diagrams with multidimensional assessments for TBT, DBT and MBT (RR = Release rate, SR = Spatiotemporal range, BA = Bioaccumulation, B = Biological activity, U = Uncertainty)

Adapted to the sediment deposition, the indicator release refers to TBT and its metabolites delivered via water, air, dust and plants (which can become food). In the evaluation of the range, the field measurements and the degradation rates for water and sediments, are taken into account. The consideration of bioaccumulation and biological activity is limited to the species which live on the deposition area or can come in contact with it. The uncertainty of each indicator is denoted with capital letters from A to D (A means lowest uncertainty) and summarised in the fifth indicator uncertainty.

Fig. 2 shows the results of each indicator together for TBT, DBT and MBT (Brandsch et al. 2001).

The risk potentials of TBT and DBT are comparable, characterized especially by their high biological activity. MBT represent a considerably lower risk potential, which only has a higher spatiotemporal range because it is more soluble and thus more mobile.

5 Discussion

The laboratory experiments show that the biological degradation is much faster under aerobic conditions and with increasing temperature. Our experiments show for the first time the dependency of the degradation rate on temperature in the range of 5° to 55°C. At high temperatures in the case of Sediment A, a complete degradation of TBT took place (no measurable concentration left, detection limit 1 µg/kg DW).

Comparing the degradation data for water and sediment, it appears that the degradation rate in water (just biological degradation, without photolysis) is almost 4 times higher because of better accessibility of the contaminants for degrading organisms.

The field studies lined out that the biological degradation of TBT in sediments starts immediately after drying. The deg-

radation rate in untreated sediment is 10% per year. Regularly restacked sediment, with better contact to air and thus preponderantly aerobic, shows a degradation efficiency of around 30% after 10 months. This fits very well with the rates determined in laboratory experiments.

All in all there was no significant change in the TBT-concentration of ground water, surrounding area, Lüne water or sediment, which could have resulted from the deposited sediment. There was no considerable TBT uptake in plants.

Concluding the presented evidences and the risk evaluation performed for the land deposition, it appears that this is a sustainable solution in dealing with TBT-contaminated harbour sediments. Compared to other disposals, it is economically one of the cheapest. From the ecological point of view, this solution is acceptable because there is no relevant risk going out. Certainly one has to take into account, that the land deposition is not a general solution for decontamination. It should be applied only to moderate contaminated harbour sediments and if, in ecological balancing, the area consumption is reasonable.

References

- Brandsch R, Nowak K-E, Binder N, Jastorff B (2001): Untersuchungen zur Nachhaltigkeit der Sanierung von Tributylzinnkontaminiertem Hafensediment durch Landablagerung. UWSF – Umweltchem Ökotox 13 (6)
- Fent K, Hunn J, Sturm M (1991): Organotins in lake sediment. Naturwissenschaften 78, 219–221
- Fent K, Müller MD (1991): Occurrence of organotins in municipal wastewater and sewage sludge and behavior in a treatment plant. Environ Sci Technol 25, 489–493
- Goldberg ED (1986): TBT: an environmental dilemma. Environment 28, 17–44
- Ranke J, Jastorff B (2000): Multidimensional risk analysis of anti-fouling biocides. ESPR – Environ Sci & Pollut Res 7 (2) 105–114

Annex 3: **Mostofizadeh Ch.: *Elimination of TBT compounds from dredged material by means of pressure thermolysis,***
Institute of Energy and Process Technology (IEV), Bremerhaven,
2001

**„Elimination of TBT compounds from
dredged material by means of
pressure thermolysis“**

Prof. Dr.-Ing. Ch. Mostofizadeh

1. Introduction

Organotin compounds are used, amongst others, as anti-fouling biocide in ship coatings to prevent shells, algae or worms from growing on the bottom of the ship. The biocides enter the aquatic environment by diffusion out of the paint layers. The toxic impact is not limited to fouling organisms, comprehensive studies have revealed that it also causes growth anomalies such, for example, as changes in the shell physiology of oysters or imposex symptoms in marine molluscs.

Organotin compounds are classified in the following groups according to the number of organic side chains:

Organotin group	Structure formula	Number of organic side chains	Abbreviation of the corresponding butyl tin compounds
Tetra-organotin compounds	$R_4 Sn$	4	Tetra BT
Tri-organotin compounds	$R_3 SnX$	3	TBT
Di-organotin compounds	$R_2 SnX_2$	2	DBT
Mono-organotin compounds	$R SnX_3$	1	MBT

Table 1: Classification of organotin compounds

Organotin compounds enrich themselves in sediment (dredged material). Dredged material therefore displays a high TBT content which can reach a scale of several 1000 $\mu\text{g}/\text{kg}$ dry substance. Thus the hazardous potential of the dredged material is extremely high and depositing it in a river or lake or on a disposal site means a negative environmental impact.

The Niedersachsen list currently lays down a threshold value of 100 $\mu\text{g}/\text{kg}$ dry substance for TBT compounds.

In the framework of a research project, a process was developed for the almost total elimination of TBT compounds and tested at pilot plant scale. The results will be reported in a summarised form.

2. Pre-studies on TBT elimination, laboratory tests

First of all a literature and database search was carried out in the framework of a study in order to show the state of the art of elimination of TBT from dredged material.

The following overview presents a synopsis:

- Grading to obtain material low in contaminants (coarse fraction > 63 μm)
- Sorting (flotation) to obtain sediment material low in contaminants
- Extraction to remove the contaminants
- Biological decomposition of the contaminants
- Thermal desorption to desorb and destroy the contaminants (with preceding drying)
- Wet-chemical oxidation with oxygen
- Combustion with air
- Addition of chemicals to produce mineral disposal site material
- Thermal/chemical bonding to produce bricks or sinter products
- Smelting and vitrification.

Only thermal desorption and combustion are able to decompose organotin compounds without adding foreign materials. The problem here is that the dredged material must be almost completely dried beforehand which not only necessitates a large energy demand but also a greater use of apparatus. In the case of combustion there is the additional aspect of the highly complex exhaust gas purification and corrosion problems. That is why the treatment costs are far in excess of 50 €/Mg dredged material.

Already known investigations in literature conclude that organic tin compounds $R_n\text{SnX}_{(4-n)}$ are thermally unstable and disintegrate in the following order: Tetra \rightarrow Tri \rightarrow Di \rightarrow Mono \rightarrow Sn-Cation. The toxicity increases with the number of butyl substitutions from 1 to 3 and decreases with the addition of the fourth butyl group. Di-organotin and Mono-organotin compounds are biologically less active and therefore far less toxic than TBT.

These physical/chemical facts formed the basis for the development of a new process for the elimination of TBT, about which the following paper reports.

In order to eliminate the TBT, the dredged material is heated to a higher temperature which has still to be determined and kept at this temperature during a dwell period, the length of which equally has still to be determined, whereby sufficient TBT decomposition occurs. In order, for energetic reasons, not to have to evaporate the water carried in the dredged

material, the treatment is carried out under high pressure. This process is called pressure thermolysis. For energetic reasons, following the decomposition of TBT and other organotin compounds, the heat from the treated dredged material is transferred to the new dredged material as it arrives.

Figure 1 shows a schematic diagram of the process.

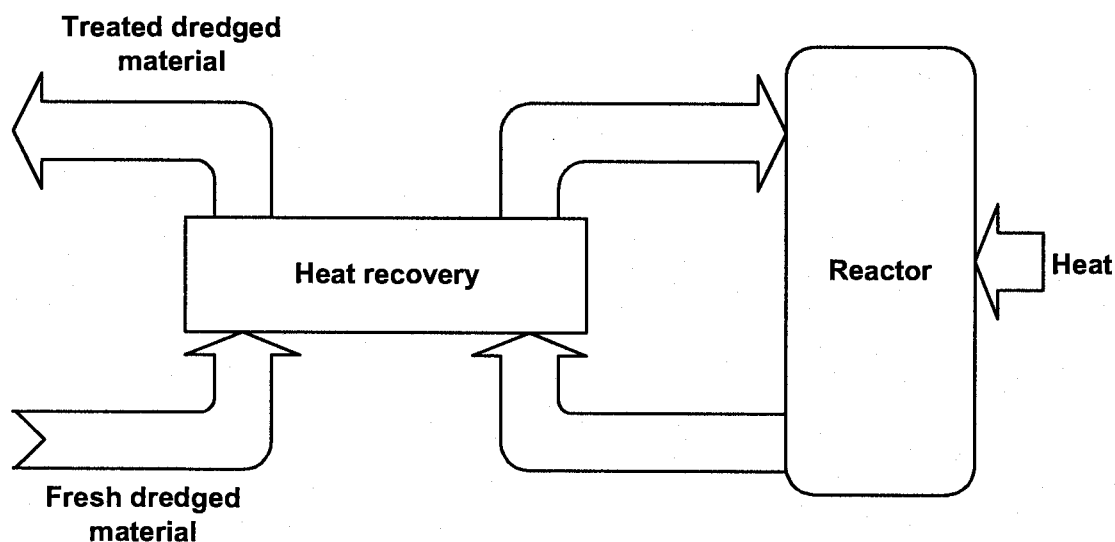

Figure 1: Principle of the treatment of dredged material by means of pressure thermolysis

The principle described was tested in a pressure pot which was heated in a laboratory oven. Various temperatures and dwell periods were set in order to be able to examine the influence on the decomposition of organotin compounds. The samples of dredged material were analysed before and after the test. Some results are summarised in Table 2. They show that the thermal treatment is responsible for a clear decomposition of organic tin compounds. The values which can be achieved depend both on the temperature as well as on the dwell period. It was noted that for a safe decomposition of TBT and to reduce DBT and MBT as well as pentachlorophenol a temperature of 230°C and a dwell period of about 2 hours are necessary. What is also clear are the TBT→DBT→MBT conversions. As the temperature approaches 230°C a direct TBT→MBT conversion can also take place. The dry substance content, degree of mixing and also the initial load also have an influence on the described parameters. The influence of the described parameters was later investigated with the help of a test unit.

Dwell time Temperature	0 20°C	2 h up to 230 °C	2 h up to 218 °C	1 h up to 160 °C
Components	Untreated dredged material	Test 1	Test 2	Test 3
Pentachlorophenol µg/kg DS	1.9	< 1 Reduction of 100 %	-	-
Monobutyltin µg/kg DS	1400	170 Reduction of 87.9 %	8200 Reduction of -585.8 %	1200 Reduction of -14.3 %
Dibutyltin µg/kg DS	5800	<1 Reduction of 100 %	2200 Reduction of 62.1 %	9800 Reduction of -169.0 %
Tributyltin µg/kg DS	160000	<1 Reduction of 100 %	1200 Reduction of 99.3 %	130000 Reduction of 18.8 %

**Table 2: Decomposition of organotin compounds
under different dwell periods and temperatures**

3. Setting up of the test analysis

The schematic arrangement of the test unit is presented in Figure 2.

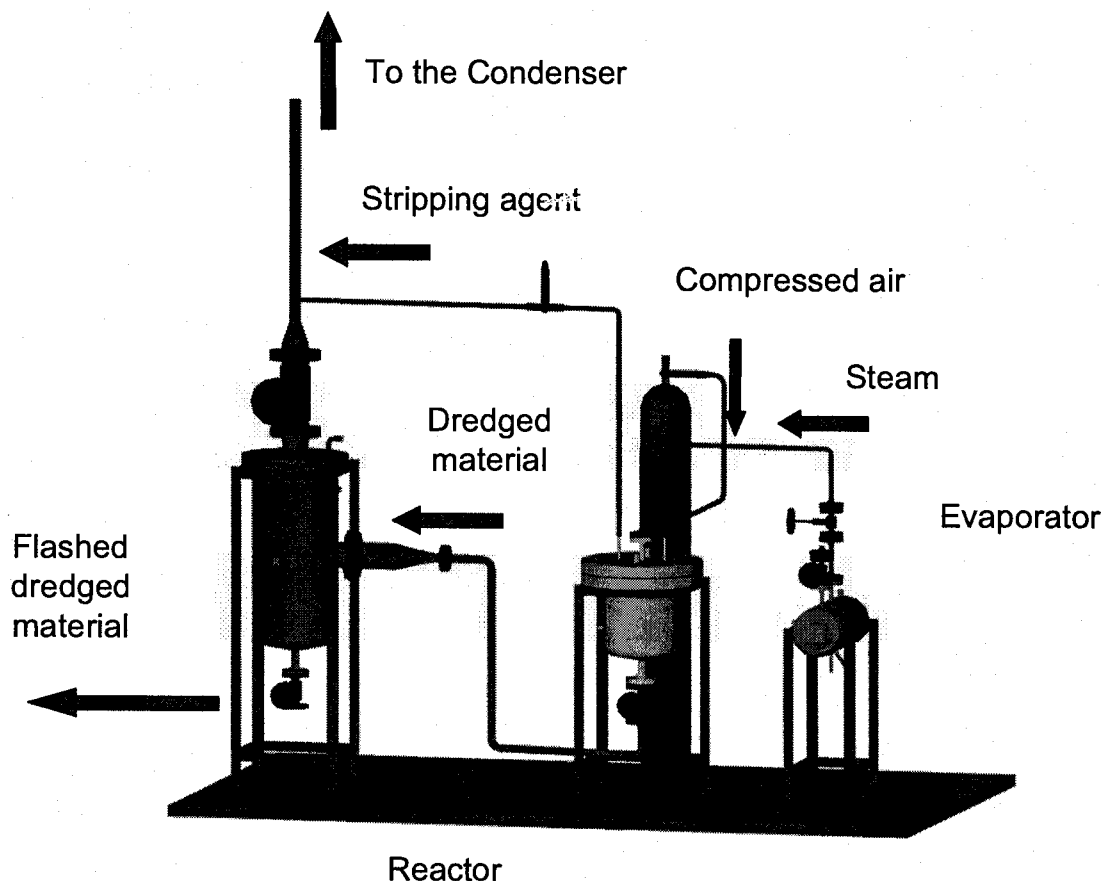

Figure 2: Schematic presentation of the test unit

The actual reactor itself is a cylindrical pressure vessel with a heating jacket and a cap which is held on by screws. Connections are foreseen on the cap for measuring temperature and pressure as well as connections through which steam and air can be introduced. The reactor holds about 20 kg of dredged material. The introduction of compressed air or steam takes place via a ring distributor in the lower part of the reactor in order to guarantee thorough mixing. Strip air and strip steam are drawn off at the cap via a pipe and fed into a water-cooled condenser. There the steam condenses. The condensate is collected and later analysed.

The heating of the reactor takes place via a thermal oil cycle in conjunction with a high-temperature thermostat. Oil temperatures of up to over 300°C can be set. The volatile components formed during the treatment can be removed by means of stripping with steam

or air. A jacket-heated evaporator, which is also heated via the thermal oil cycle, is used to produce strip steam. Steam can be produced there with a pressure of up to 40 bar. The strip air is obtained as compressed air from a bottle and can be heated by means of an electrical heat conductor prior to entry into the reactor. The air and the steam volumes are measured volumetrically.

To carry out the tests, the reactor is filled with a specific amount of dredged material (about 16-20 kg) and closed tightly. The heating procedure then follows which generally takes 1.5 to 2 hours. Then follows the actual treatment itself at a constant temperature. After a specific dwell period (e.g. 2 hours), steam or air can be blown in for the purpose of stripping phenol compounds. The dredged material is subsequently expanded via a expansion valve into a let down vessel to atmospheric pressure. The steam produced in the process is condensed in the condenser. The dredged material then has a temperature of slightly more than 100°C and can, after it has cooled down further, be analysed.

Figure 3 shows a photograph of the test unit with the following components: Reactor, let down vessel and high-temperature thermostat. The reaction conditions of 230°C and about 35 bar can be set with this arrangement with no difficulty.

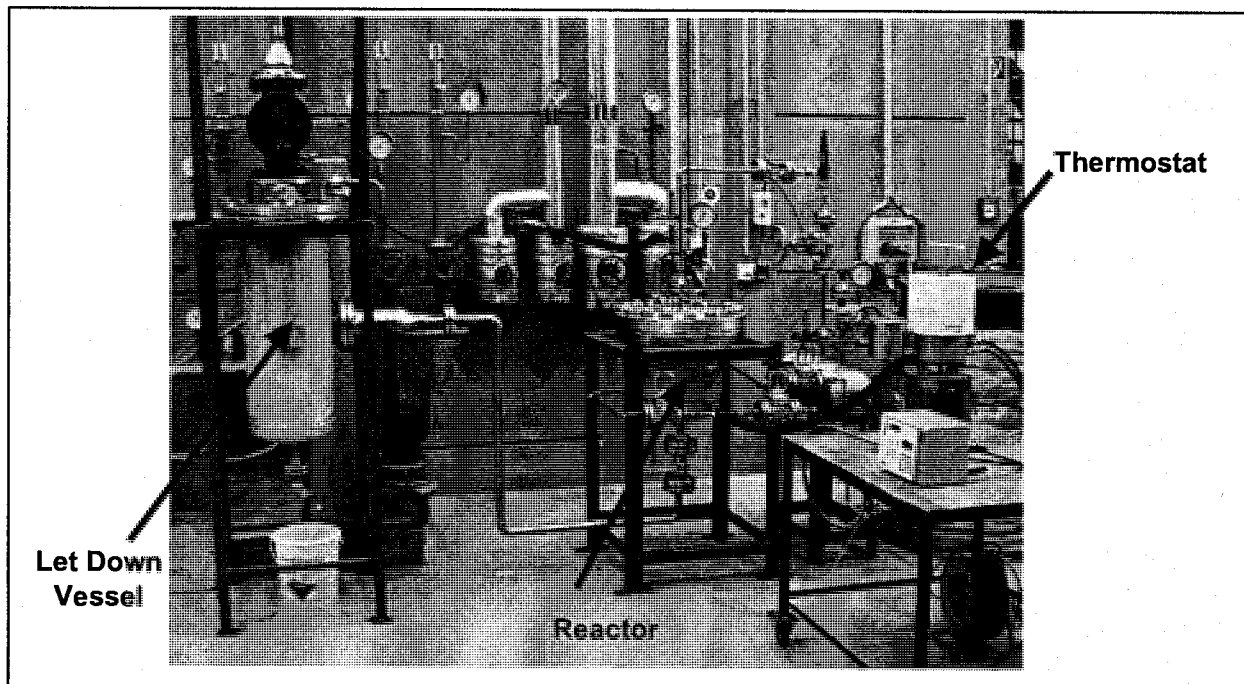

Figure 3: Photograph of the test unit

Numerous trials were implemented with the test unit in order to optimise the process parameters with regard to adherence to the chemical and biotoxic criteria. The GL value determined by means of a luminous bacteria test served first of all as a biotoxic criterion. Further biotests were later added.

4. Results

Table 3 shows an extract of the results with air stripping over a longer dwell period of 3 hours.

*beginwaarden
" baggerlic*

Description	Method	Unit	Sample D40	Sample D41	Sample D50	Sample D51	Sample D52	Sample D70
Dry substance (105°C)		%	28.5	42.1	51.1	50.2	33.5	29.8
Organ. tin compounds	GC-FPD							
Monobutyltin cation		µg/kg DS	<1	14	<1	3	22	120
Dibutyltin cation		µg/kg DS	<1	<1	<1	<1	28	530
Tributyltin cation		µg/kg DS	<1	<1	<1	<1	280	5100
Tetrabutyltin		µg/kg DS	<1	<1	<1	<1	<1	
Tricyclohexyltin cation		µg/kg DS	<1	<1	<1	<1	<1	
Triphenyltin cation		µg/kg DS	<1	<1	<1	<1	<1	
Bio luminescence test	DIN 38412-L34	LID	2	4	1	1	1	2
Green algae test	DIN 38412-L33	GA	16	2	4	2	4	4
Daphnia magna test	DIN 38412-L30	GD	4	2	2	1	4	2

Table 3: Results with air stripping (3 h, 230°C, 35 bar); Sample D40 only cold stripped; Sample D52 is untreated dredged material with a low contaminant load; Sample D70 highly contaminated dredged material as base material.

In the case of all the samples treated the organotin compounds were almost completely decomposed. Sample D40 was only stripped with cold air after the dredged material had cooled down. This alone is probably not sufficient to achieve an acceptable result in the green algae test as well; or else the volume of air and the stripping time must be increased. The other samples, D41, D50 and D51, were hot-stripped in the reactor. In order to compare, the values of dredged material with a low contaminant load (Sample D52) and of the original dredged material (D70), with which tests were carried out, are also presented. Those values are of interest here which represent the biotoxicity. In comparison to the raw sample, better values were achieved.

5. Design of the unit and economic viability

Following implementation of the tests, two units with annual capacities of 85.000 and 170.000 Mg/a were designed in order to calculate the consumption values and the costs. The unit is erected on a pontoon (Figure 4) and primarily comprises the following components:

- Receiver tank
- Heat exchanger for pre-warming
- Reactor
- Steam boiler + thermal afterburner
- Let down vessel for cooling down the dredged material
- Diesel drive
- Pumps, fittings, pipelines
- Measuring and control apparatus

The consumption values are as follows:

Thermal energy	140 kWh / Mg
Electrical energy	16 kWh / Mg

Under consideration of all costs, the amount of treatment costs is about 11.5 – 15 €/Mg dredged material.

Water containing TBT can also be treated with the process described.

In this case the consumption values and the costs are considerably lower.

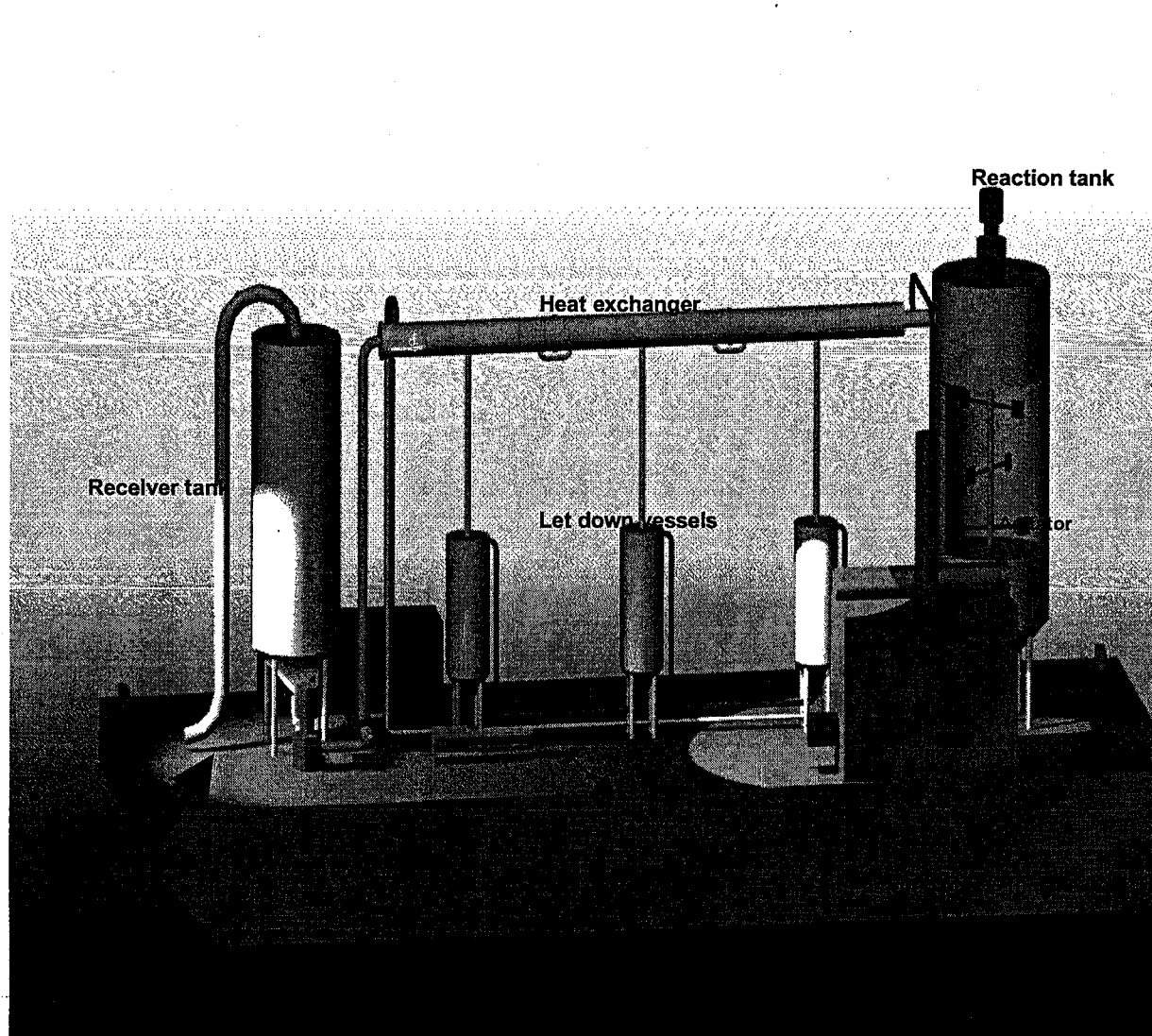

Figure 4: Perspective presentation of the treatment unit

Annex 4: Stichnothe et al., 2001 & 2002:

ANNEX 4.1 Stichnothe H., Thöming J., Calmano W.:
*Detoxification of tributyltin contaminated sediments
by an electro-chemical process,*
The Science of the Total Environment 266, p. 265-
271, 2001

ANNEX 4.2 Stichnothe H., Keller A., Thöming J., Lohmann N,
Calmano W.: *Reduction of tributyltin and other
organic pollutants of concern in contaminated
sediments by means of an electrochemical oxidation,*
Acta hydrochim. Hydrobiol. 30 (2002)2-3, p87 - 93



ELSEVIER

The Science of the Total Environment 266 (2001) 265-271

the Science of the Total Environment

An International Journal for Scientific Research into the Environment and its Relationship with Man

www.elsevier.com/locate/scitotenv

14 JAN. 2003

Detoxification of tributyltin contaminated sediments by an electrochemical process

H. Stichnothe*, J. Thöming, W. Calmano

Technical University Hamburg-Harburg, Department of Environmental Science and Technology, Eissendorferstrasse 40, 21073 Hamburg, Germany

Received 17 September 1999; accepted 28 June 2000

Abstract

Preliminary experiments have shown that dibutyl and tributyltin can be decomposed by the electrochemical treatment of sediment. Two different process pathways have been described and compared. A slurry electrolysis of the suspended sediment seemed to be more efficient than column leaching followed by electrolysis. Tributyltin was destroyed under oxidising as well as under reducing process conditions. The detoxification mechanism seemed to be stepwise removal of the butyl groups. A partial debutylation of tri- and dibutyltin could be achieved, although monobutyltin was not affected. This technique is promising, but further investigation is necessary to improve the experimental conditions and to characterise the real potential of these process pathways. © 2001 Elsevier Science B.V. All rights reserved.

Keywords: Organotin; TBT; Sediment; Electrolysis; Column leaching

1. Introduction

In the 1940s, the commercial use of organotin compounds started with dibutyltin as a stabiliser in polyvinyl chloride (PVC). Since the 1950s, ex-

tended research on the properties and synthesis of these compounds was carried out in the Netherlands and the powerful biocidal properties of the trialkyltin and triaryl tin derivatives, in particular, were established. The German company Hoechst produced the first organotin-based fungicide in 1957. Since the early 1960s, organotin compounds were used as additives in antifouling paints. Organotin cations consist of a central Sn atom linked to organic substituent groups. Typical

* Corresponding author. Tel.: +49-40-428783319; fax: +49-40-428782315.
E-mail address: stichnothe@tu-harburg.de (H. Stichnothe).

substituents are phenyl- and butyl groups; as an anion, chloride is frequently used (Evans and Karpel, 1985).

Organotin compounds are used in/for:

- Polymer stabilisers
- Catalysers for polymer production (polyurethanes, silicones, esters)
- Materials and textiles protection
- Wood preservation
- Agricultural chemicals
- Antifouling paints

The last three applications especially have led to widespread distribution of these substances in the environment (de Mora, 1996; Commission of the European Communities 1988; Dobson and Cabridenc, 1990).

Triorganotin compounds belong to the most toxic substances humans ever released into the environment in large scale. In the 1980s, the oyster population at the French Atlantic coast decreased dramatically due to the tributyltin (TBT) enrichment in the environment (Alzieu, 1991). Further investigations in Europe, the United States, Japan and India (Chaloux et al., 1998; Fukushima et al., 1998; Singh et al., 1998) showed that other non-target marine species, such as shellfish and snails, also were affected.

The use of organotin-containing antifouling paints was first restricted by the French government in 1982 and then by the European Commission in 1989 after intensive investigations about the influence of organotin on the marine ecosystem. Imposex and intersex of snails (Porte et al., 1998; Umweltbundesamt, 1989) was found to be a widespread phenomenon which is caused by the organotin compounds. Many monitoring, degradation and ecotoxicological investigations (Valkers et al., 1988; Unger and Greaves, 1988; Lee et al., 1992) concerning the behaviour of organotin species in the environment and their effect on marine organisms have been conducted all over the world.

Every year, enormous amounts of sediment have to be dredged from waterways and harbours to ensure the navigation depth of the channel. These sediments are contaminated with organotin

compounds and must be treated before relocation. While biodegradation has been postulated in the literature (Unger and Greaves, 1988; Kurokawa et al., 1998) as a possible treatment for the sediments, there is no strong evidence that organotins will be destroyed microbiologically in an acceptable time scale (de Smaele et al., 1998; Sakai et al., 1995). A second approach to destroy these substances is a mechanical classification with a final thermal treatment of the polluted fine-grained fraction. This method is very energy consuming and expensive. Our new approach was to detoxify the sediment by means of electrochemical treatment. Two different process pathways have been compared in this paper. First, a leaching step in a counter-current extraction column was combined with a subsequent electrochemical treatment of the liquid. This led to the decomposition of organotin compounds where the cleaning agent could be recirculated. Secondly, we have used a direct electrochemical treatment of suspended sediment.

2. Materials and methods

2.1. Samples

Two sediment samples were collected from the harbour of Bremerhaven in northern Germany. One sample was taken from a location close to a dockyard, and thus it was extremely contaminated with TBT (up to 100 000 $\mu\text{g}/\text{kg}$). The second one (400 μg TBT/kg) originated from a navigation channel.

2.2. Analytical procedure

The analysis of the organotin species was conducted by in-situ derivatisation of the organotin cations with sodiumtetraethylborate (NaBEt_4) and extraction with *n*-hexane. A GC-FPD system was used for detecting the organotin cations. The ionic tin was analysed via ICP/OES.

2.3. Batch extraction tests

Sediment (200 g) was suspended in sodium

chloride solutions (1 and 5 M) The suspensions were stirred for 24 h and then centrifuged and filtered (0.45 μm). Both solid and liquid phases were analysed for butyltin compounds.

2.4. Counter-column extraction and electrochemical treatment

An extraction column was filled with ca. 1 kg of the sediment and leached upwards with electrochemically activated saline solution to destroy the organotin compounds. After a solid/liquid separation the liquid was reactivated in the electrolysis cell and reused. In that manner, a circuit was realised. We used a divided electrolysis cell with a canvas-diaphragm. All experiments were conducted at room temperature with current densities of approximately 17 A/m² at the anode and 23 A/m² at the cathode. The cell voltage was between 3 and 5 V, Fig. 1.

2.5. Slurry electrolysis

The sediment was suspended with saline solution (1 M) and then transferred downwards into an electrochemical cell and circulated by pumping for up to 48 h. This process was conducted in two different ways, i.e. using the anodic chamber or the cathodic chamber, which were separated from each other with a diaphragm, Fig. 2.

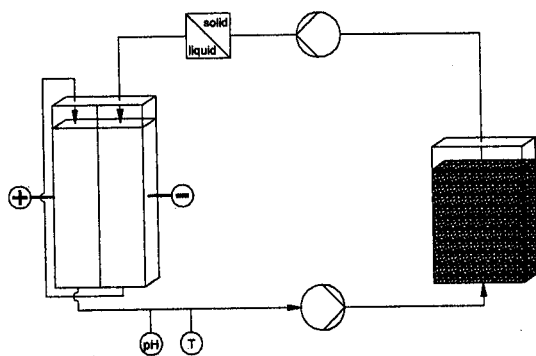

Fig. 1. the process for column leaching with subsequent electrolysis.

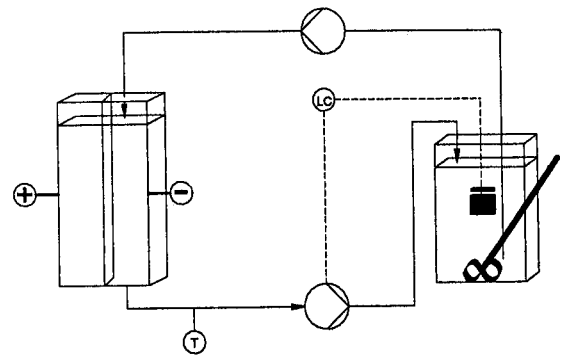

Fig. 2. the process for slurry electrolysis.

3. Results and discussion

The samples from the two locations in the port of Bremerhaven were analysed and the results are shown in Table 1.

The TBT distribution in the highly polluted sediment originating from the basin of a dockyard was very heterogeneous. The organotin concentration in the sediment decreased in the order TBT > DBT > MBT. This distribution was caused by the different water solubilities and hydrophobic nature of the various butyltin species.

From the literature (Shiraishi et al., 1995; Bueno et al., 1998), it is well known that the content of organotin species in sediments depends on salinity, pH, organic matter content and temperature. Thus, it should be possible to remove the exchangeable part of the butyltin com-

Table 1

Butyltin (monobutyltin (MBT), dibutyltin (DBT) and tributyltin (TBT)) concentrations in the original high contaminated (HC) and relatively low contaminated (LC) (n = 2) sediments

Sample	MBT [μg/kg]	DBT [μg/kg]	TBT [μg/kg]
HC	920	3700	68 000
HC	860	4800	125 000
mean HC	890	4250	96 500
LC	26	46	330
LC	31	48	430
mean LC	28.5	47	380

Table 2
Residual butyltin concentrations after stirring with 1 M and 5 M, respectively NaCl solution

Sample	Time [h]	NaCl conc. [M]	MBT [$\mu\text{g}/\text{kg}$]	DBT [$\mu\text{g}/\text{kg}$]	TBT [$\mu\text{g}/\text{kg}$]
HC	1	1	560	2500	49000
HC	36	1	890	2000	47000
HC	1	5	280	1100	28000
HC	36	5	310	1030	23000
LC	1	1	31	44	330
LC	36	1	37	48	430
LC	1	5	17	29	210
LC	36	5	17	31	230

pounds from the sediment by ion exchange and then to destroy them in the aqueous phase by means of electrolysis.

Therefore, batch extraction tests were carried out to investigate if the butyltin species could be transformed to the aqueous phase. The sediment was suspended in 1 and 5 M NaCl solution in a ratio of 1:10 and stirred for up to 36 h to determine the maximum transformation rate due to ion exchange. The results are summarised in Table 2.

The exchange reaction took place rapidly and equilibrium was reached in approximately 1 h or less. By increasing the stirring time up to 36 h, the concentration of butyltins in the aqueous phase increased only slightly. Nevertheless, it was not possible to determine a mass balance for these experiments. In contrast to the extraction

time, the salinity of the solution had a large influence on butyltin levels: in a 5 M NaCl solution, the extraction rate was approximately four times higher than in a 1 M NaCl solution. For the LC sediment, this effect was smaller. We assumed that this part of butyltin was ionically bound to the sediment and the remaining part was associated with organic matter.

Counter-column experiments coupled with electrolysis were conducted by pumping a 1 M NaCl solution through the anodic, and afterwards through the cathodic chamber of the electrolysis cell. Using this process, HOCl was produced and used as an oxidising agent for butyltin decomposition. The process scheme is shown in Fig. 1.

The following reaction took place within the electrolysis cell:

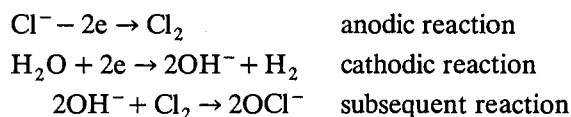

Besides the formation of OH^- and H_2 , radicals appeared due to water electrolysis close to the electrodes. These species were very reactive and, thus, they contributed to the detoxification of organotin species.

Thermodynamic calculations supported the assumption that a reductive as well as an oxidative treatment of organotin compounds should be possible. The calculation for an aqueous system containing 1 M chloride is shown in Fig. 3.

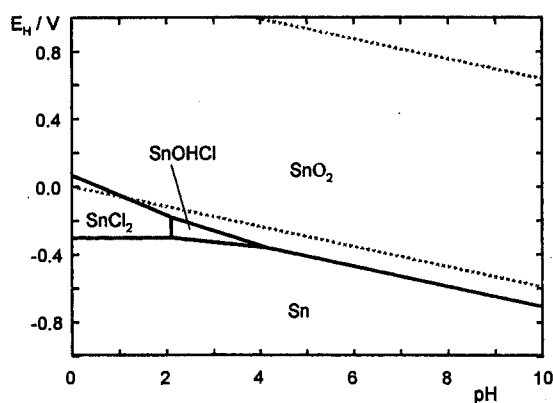
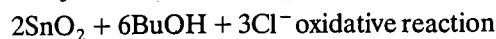
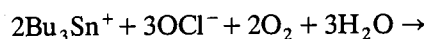

Fig. 3. E_{H}/ pH -diagram of the system Sn-Cl at 25°C in 1 M NaCl solution.

Table 3
Results from the counter-current leaching/electrolysis (Cc + elec) experiments

Experiment	Sediment	Treatment	MBT [$\mu\text{g}/\text{kg}$]	DBT [$\mu\text{g}/\text{kg}$]	TBT [$\mu\text{g}/\text{kg}$]
1	LC	Cc + elec.	94	130	15
2	HC	Cc + elec.	614	3752	32100
3	HC	Cc + elec.	2610	1457	37000

Most likely, the detoxification mechanisms are:



Column experiments with subsequent electrochemical treatment of the liquid were carried out and the results are summarised in Table 3. In contrast to experiments 1 and 2, which were conducted as described above, in experiment 3, liquid was passed through just the cathodic chamber to maintain reductive conditions within the leaching column. Experiment 1 was conducted with the low contaminated sediment. After 20 h, the concentration of TBT decreased from 430 to 15 $\mu\text{g}/\text{kg}$, whereas the concentrations of DBT and of MBT increased from 48 to 130 $\mu\text{g}/\text{kg}$ and from 31 to 94 $\mu\text{g}/\text{kg}$, respectively. During the second experiment, the highly polluted sediment was treated in the same way and the concentration of all butyltin species decreased during the treatment. MBT could be reduced from 890 to 614 $\mu\text{g}/\text{kg}$, DBT from 4250 to 3752 $\mu\text{g}/\text{kg}$, and TBT from 96500 to 32100 $\mu\text{g}/\text{kg}$. A third experiment was conducted using just the cathodic chamber of the electrolysis cell to avoid any chlorine formation. From this procedure, it was possible to reduce DBT and TBT while the MBT content increased. The TBT concentration decreased in all experiments while the DBT and MBT concentration increased. This led to the conclusion that the mechanism of detoxification is a stepwise debutylation of the butyltin compounds.

The detoxification of sediment could be conducted by an oxidative or a reductive process. Total reduction of the organotin concentrations

could not be achieved. To enhance the detoxification rate, slurry electrolysis also was conducted. The HC sediment was suspended in NaCl solution and pumped directly into the anodic chamber of the slurry electrolysis cell, as shown in Fig. 2. After stirring the suspension for 1 h, a sample was taken and then the electric field was applied. Samples were taken after 0.5, 2, 4 and 24 h of treatment. The results are shown in Table 4.

The TBT concentration decreased from 96500 to 110 $\mu\text{g}/\text{kg}$, the DBT concentration increased during the first 4 h of the treatment from 4250 to 6000 $\mu\text{g}/\text{kg}$, and was then decreased to 2400 $\mu\text{g}/\text{kg}$. The MBT load increased during the treatment from 890 to 14000 $\mu\text{g}/\text{kg}$. The results are illustrated in Fig. 4.

Obviously the detoxification mechanism is a stepwise splitting off of the butyl group, but the detoxification seems to stop at MBT, which could not be further debutylated electrochemically. The possibility of a further detoxification should be investigated under different electrolysis conditions, pH, temperature, voltage etc.

4. Summary and conclusions

Preliminary experiments have shown that a debutylation of TBT and DBT in sediments is possi-

Table 4
Results from the slurry electrolysis with the HC sediment

Time [h]	MBT [$\mu\text{g}/\text{kg}$]	DBT [$\mu\text{g}/\text{kg}$]	TBT [$\mu\text{g}/\text{kg}$]
0	890	4250	96500
0.5	730	3800	26000
2	1300	4800	22000
4	3200	6000	14000
24	14000	2400	110

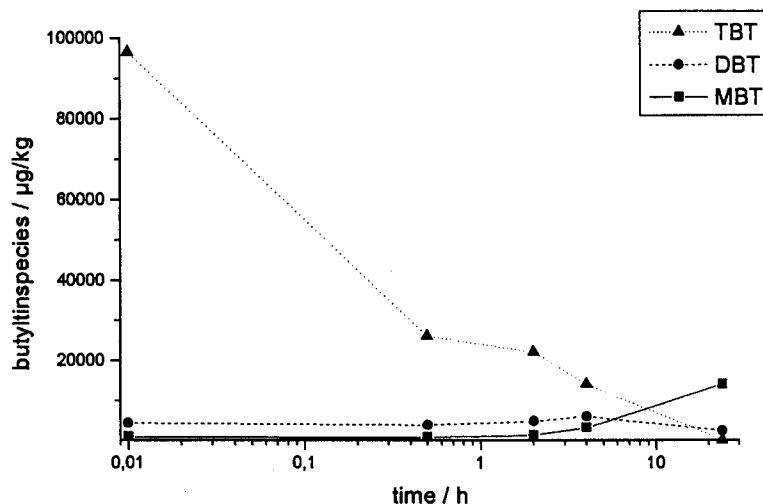

Fig. 4. Slurry electrolysis of highly butyltin contaminated sediment with 1 M NaCl solution in a ratio of 1:1 under oxidising conditions.

ble by means of an electrochemical treatment. These butyltin compounds can be destroyed using two different process pathways, a reductive and oxidative one. Due to the association of the butyltin species with the organic matter, these complexes have to be 'cracked' chemically and/or mechanically to detoxify the sediment. In both processes a stepwise debutylation seems to be the detoxification mechanism. The same mechanism was supposed to be the biological degradation path. The assumption of the reaction path has to be verified by further investigations. Even though the MBT was not reduced yet, with this technique the sediment can be detoxified significantly. This is due to the tremendous difference in toxicity between the butyltin species, TBT and MBT. Literature data (Argese et al., 1998) show that the effective concentration (EC50) of tributyltin is approximately 9000-fold higher than butyltin (calculated for butyltins as chloride from toxicity data). Additional work is needed to improve the experimental conditions and to characterise the real potential of these process pathways.

References

- Alzieu C. Environmental problems caused by TBT in France. *Mar Env Res* 1991;32:7–17.
- Argese E, Bettiol C, Ghiradini AV, Fasolo M, Giurin G, Ghetti PF. Comparison of vitro submitochondrial particle and Microtox® assays for determining the toxicity of organotin compounds. *Env Toxicol Chem* 1998;17: 1005–1012.
- Bueno M, Astruc A, Astruc M, Behra P. Dynamic sorptive behavior of tributyltin on quartz sand at low concentration levels: effect of pH, flow rate and monovalent cations. *Env Sci Technol* 1998;32:3919–3925.
- Chaloux N, Bayona JM, Zeng E, Venkatesan MI. Butyltins in sediments from Santa Monica and San Pedro basins, California. *Env Poll* 1998;99:263–269.
- Commission of the European Communities, Environment and Life Quality, Luxembourg, 1988
- Dobson S, Cabridenc R. Tributyltin compounds. Geneva: World Health Organization, 1990.
- Evans CJ, Karpel S. Organotin compounds in modern technology. Amsterdam: Elsevier, 1985.
- Fukushima M, Yamamoto Y, Kawai S, Miyazaki N, Harino H. Contamination of Butyltin and phenyltin compounds in the marine environment of Otsuchi Bay, Japan. *Env Poll* 1998; 99:209–214.
- Kurokawa Y, Harino H, Fukushima M, Kawai S. Degradation of tributyltin by a bacterial strain isolated from polluted river water. *Env Poll* 1998;102:259–263.
- Lee RF, Seligman PF, Stang PM. Evidence for rapid, nonbiological degradation of tributyltin compounds in autoclaved and heat-treated fine-grained sediments. *Env Sci Technol* 1992;26:1382–1387.
- de Mora SJ. Tributyltin: case study of an environmental contaminant. Cambridge: Cambridge University Press, 1996.
- Porte C, Solé M, Morcillo Y. Imposen in the commercial snail *Bollinus brandaris* in the northwestern Mediterranean. *Env Poll* 1998;99:241–246.

- Sakai S, Takatsuki H, Watanabe N. Release and degradation half lives of tributyltin in sediments. *Chemosphere* 1995; 31:2809–2816.
- Shiraishi H, Soma Y, Inaba K. Effects of salinity, pH and temperature on aqueous solubility of four organotin compounds. *Water Res* 1995;29:1415–1417.
- Singh IB, Tobschall HJ, Ansari AA. Organotin compounds in surface and pore waters of Ganga Plain in the Kanpur-Unnao industrial region, India. *Sci Total Env* 1998;223: 157–166.
- de Smaele T, Moens L, de Jong AS, Donard OFX, Ritsema R. Determination of butyltins in harbour sediments and water by aqueous phase ethylation GC-ICP-MS and hydride generation GC-AAS. *Env Poll* 1998;99:271–277.
- Umweltbundesamt, Abschätzung des Eintrags und der Verteilung von organischen Substanzen in Oberflächengewässern, Sedimenten, Klärschlämmen und Böden, Berlin, (1989)
- Unger MA, Greaves J. A selected ion monitoring assay for tributyltin and its degradation products. *Biomed Env Mass Spectrom* 1988;15:565–569.
- Valkers AO, Stang PM, Lee RF, Seligman PF. Evidence for rapid degradation of tributyltin in a marina. *Mar Poll Bull* 1988;19:531–534.

r oxidising

ial particle
toxicity of
1998;17:

ic sorptive
concentration
tions. *Env*

utyltins in
sins, Cali-

iment and

. Geneva:

lern tech-

Harino H.
nds in the
Poll 1998;

gradation
polluted

l, nonbio-
utoclaved
Technol

onmental
ess, 1996.
cial snail
ean. *Env*

Heinz Stichnothe^a,
Arne Keller^a,
Jörg Thöming^b,
Nina Lohmann^c,
Wolfgang Calmano^a

Reduction of Tributyltin (TBT) and Other Organic Pollutants of Concern in Contaminated Sediments by means of an Electrochemical Oxidation

^a Technical University
Hamburg-Harburg,
Dept. Environmental Science
and Technology,
Eissendorfer Str. 40,
21073 Hamburg, Germany

^b University of Bremen,
Dept. Process Integrated
Waste Minimization,
Badgasteiner Str. 1,
28359 Bremen, Germany

^c Technical University
Hamburg-Harburg,
Dept. of Waste Management,
Harburger Schloßstr. 36,
21079 Hamburg, Germany

In contaminated sediments butyltin compounds and PAH can be diminished by means of an electrochemical treatment. The butyltin concentrations of the fine fraction (particle size <20 µm) of a mechanical separation unit were reduced from 350 µg/kg to <10 µg/kg for tetrabutyltin (TeBT), from 2600 µg/kg to <30 µg/kg for tributyltin (TBT), 380 µg/kg to <100 µg/kg for dibutyltin (DBT), and from 570 µg/kg to <100 µg/kg for monobutyltin (MBT), respectively. Furthermore the sum of PAH concentrations for 16 PAH descended approximately 90% during a residence time in the electrolysis cell of 3 h, while in contrast PCB concentrations remained the same before and after the treatment. Apparently, the presence of PCB limited the application of this process, if the initial concentration exceeded guideline values for relocation. Further investigations have to be undertaken to clarify this point. Nevertheless the promising results obtained from a technical treatment unit have led to the construction of a pilot plant, which is installed in Bremen and operating since the beginning of 2002.

Verminderung der Konzentration von Tributylzinn (TBT) und anderen relevanten organischen Schadstoffen in kontaminierten Sedimenten mittels elektrochemischer Oxidation

Durch elektrochemische Oxidation können die Konzentrationen von Butylzinnverbindungen und PAK in kontaminierten Sedimenten vermindert werden. Die Konzentrationen von Butylzinnverbindungen aus der Feinkornfraktion (<20 µm) einer mechanischen Sedimentbehandlungsanlage wurden von 350 µg/kg auf <10 µg/kg Tetrabutylzinn (TeBT), von 2600 µg/kg auf <30 µg/kg Tributylzinn (TBT), von 380 µg/kg auf <100 µg/kg Dibutylzinn (DBT) und von 570 µg/kg auf <100 µg/kg Monobutylzinn (MBT) verringert. Außerdem verringerte sich die Summe von 16 PAK um ca. 90% innerhalb einer Verweilzeit von 3 h in der Elektrolysezelle. Im Gegensatz dazu blieb die Konzentration der untersuchten PCB konstant. Vermutlich begrenzt diese Schadstoffklasse die Anwendung des Verfahrens, wenn die Ausgangskonzentration im Sediment über den für eine Umlagerung relevanten Grenzwert liegt. Weitere Untersuchungen sind notwendig, um die Grenzen der Anwendung dieses Verfahrens zu untersuchen. Aufgrund der vielversprechenden Ergebnisse mit der Technikum-anlage ist eine Pilotanlage konstruiert und gebaut worden. Die Anlage wird seit Anfang 2002 in Bremen betrieben.

Keywords: Dredged Material, Butyltin Compounds, PAH, PCB, Sediment Treatment

Schlagwörter: Baggergut, Butylzinnverbindungen, PAK, PCB, Sedimentbehandlung

Correspondence: H. Stichnothe, E-mail: stichnothe@tu-harburg.de

1 Motivation

Tributyltin (TBT) is used as additive in antifouling paintings. Inhibition of microbiological growth on underwater ship surface reduces fuel consumption. This is a desirable economic and ecological benefit [1]. But the usually applied self-polishing paintings cause a permanent release of organotin compounds into the environment [2]. Therefore significant concentrations of TBT can be found in harbour and harbour navigation channel originated sediments but also in sediments from freshwater lakes [3]. TBT has endocrine properties [4, 5], and is like PCB and DDT persistent in sediments and accumulates in the food web [6, 7].

Hamburg and Bremerhaven are the most important harbours in Germany and located in the north of Europe. To ensure the depth of navigation channels in these both harbours 1.5...2 Mio m³ sediment have to be dredged every year and approximately 1.3 Mio m³ of this dredged material has an organotin contamination above 100 µg/kg. In Bremerhaven the dredged material is disposed on land and in Hamburg after mechanical separation, too.

Recently TBT has been defined as hazardous priority substance within the European water framework, which means that its emission has to be reduced to zero within one generation or approximately 20 years. At present there is no official limit value for TBT in sediments, but in practice nobody would get a permission for dredged material relocation in Germany with a TBT concentration above 100 µg/kg (related to dry weight).

TBT ban will pose a legacy problem after transferring the framework into national laws or guideline values. At present no economically acceptable treatment method apart land filling is available. Efforts were undertaken by Belgium [8] and Germany [9] to reduce organotin and especially TBT applications by national laws. Belgium wanted to ban all organotin antifouling paintings from 2003, which stays in agreement to international negotiations through the International marine organisation (IMO). Both efforts are rejected by the EU [10]. It seems that to realise a ban of TBT takes some time and an interim solution is needed until TBT release into the environment disappears.

Our approach is to use an electrochemical sediment treatment process, which might become an alternative to the common practice. For the investigations we used fine fraction from a mechanical sediment separation unit in Hamburg. After separation of coarse material like bikes, cars, stones, or tires, the dredged material is classified into three main fractions within this plant:

1. Sand
2. Fine sand
3. Silt/fine silt

The silt fraction is usually relatively highly contaminated with all kinds of pollutants and therefore the most challenging material for a decontamination process. This fraction is chosen to verify former results from laboratory experiments and to ensure that those results are transferable in the up-scaling process. Due to the abrasive properties of sediments special requirements for the electrode materials are needed:

- Mechanical stability
- High yield of oxidising species
- No dissolution as anodes
- The material itself must be non-toxic.

Titanium modified metal oxide electrodes can perform such requirements [11]. New developments with doped carbon electrodes are very promising [12], but these electrodes are just recently commercially available in a larger scale.

The principle of the electrochemical treatment is to generate highly reactive radicals, or oxidising species at the electrodes, which are able to destroy the bonding between the central tin atom and the butyl ligands. This is possible on an oxidative as well as on a reductive pathway [13]. As probable products inorganic tin, butanol, and/or butane will be formed. Also organics, especially aromatic compounds, are oxidised by electrochemically generated radicals [14, 15].

The electrochemical process for sediment treatment has been mentioned by Stichnothe et al. [16]. Further investigations by the same authors have shown that the main process parameters are current density and chloride concentration [17]. This is in agreement with results from Comninellis [18], who investigated the oxidation of phenol in presence of chloride, and from Kraft et al. [19] concerning drinking water disinfection. Besides butyltin decomposition, behaviour of organics, e.g. PAH, PCB, and mobility of heavy metals influenced by the electrochemical treatment are of great interest for the application and assessment of the process, because these parameters are also relevant for the relocation of treated sediments. As neither the concentration of heavy metals nor their mobility behaviour change due to the treatment [17], only PAH, pesticides, and PCB will be discussed in this paper.

Maihot et al. [20] described the photo-induced degradation of TBT in water, identified most of the photoproducts, and proposed a hydroxyl-radical based mechanism. In the early stage of the degradation of TBT, DBT and MBT occur as intermediate products. After long irradiation time they just detected inorganic tin, mainly SnO₂, remaining in solution, besides determination of carbon dioxide formed by oxidation of butyl groups was in very good agreement to theoretical calculations.

2 Materials and methods

2.1 Samples

The sample was taken from a mechanical sediment separation unit in Hamburg (METHA) and originated from a location

in Hamburg Harbour. The size fraction $<20\ \mu\text{m}$ was selected for further treatment.

2.2 Analytical procedure

For organotin and organic analysis the samples were centrifuged and freeze-dried. The analysis of organotin species was conducted by in-situ derivatisation of the organotin cations with sodium tetraethylborate (NaBEt_4) after acidifying and extraction with *n*-hexane. The hexane extract was cleaned up with silica gel and concentrated to a small volume. Tripropyltin and tetrapropyltin were used as internal standards. A GC-AED (HP 8890 GC-HP G 2350 AED) system was used for determination of organotin species. Analyses were conducted in duplicates and average values were denoted. Detection limits according to DIN 32645 for the butyltin analysis are shown in Table 1.

Table 1: Detection limits for butyltin analysis.

Nachweisgrenzen der Butylzinnverbindungen.

	Detection limit, $\mu\text{g}/\text{kg}$	Confidence interval, $\mu\text{g}/\text{kg}$	
		lower	upper
MBT	3.0	1.8	7.2
DBT	11.2	6.9	27.4
TBT	6.6	4.1	10.0
TtBT	7.8	4.8	19.0

For PAH analysis 4 g dry sediment were treated with *n*-hexane/dichloromethane (ratio 1:1) 6 h in a Soxhlet extractor. The extract volume was reduced to 2 mL by a rotary evaporator. The samples were analysed in duplicates with a GC-MS (HP5890II - MSD 5971A) system.

For PCB analysis 4 g dry sediment were extracted with *n*-hexane in a Soxhlet extractor for 6 h. The extract was cleaned up with silica gel and silver nitrate. After concentration to 2 mL with a rotary evaporator, measurements were conducted as duplicates using a GC-ECD system of Perkin Elmer.

Chlorobenzenes and pesticides were analysed after extraction similar to the procedure for PCB, but using *n*-hexane/diethyl ether instead of just *n*-hexane. The determination was conducted with the same system as for PCB.

2.3 Electrolysis

Based on experiments in a laboratory cell the experiment was conducted in a technical scale. The storage tank had a volume of $2\ \text{m}^3$ and the electrolysis cell a free volume of 30 L. IrO_2 anodes and steel cathodes with approximately surface ratio of 1:2 were used (anode area $2\ \text{m}^2$). The power supply could deliver a current of maximum 300 A and a voltage of 20 V. To maintain the sediment in suspension a stirrer was needed. The process scheme is shown in Figure 1.

In order to enhance conductivity NaCl addition is needed for freshwater sediments, while marine sediments usually contain sufficient electrolytes. After suspension in 0.5 M NaCl solution the sediment was transferred upwards into an electrochemical cell and circulated by pumping in the electrolysis cell to examine different residence times. The experiments were carried out with current density at the anodes of $80\ \text{mA}/\text{cm}^2$.

3 Results and discussion

Only butyltin species were found in the fine-grained sediment from the mechanical separation unit in Hamburg, phenyl tin and cyclohexyltin compounds could not be detected. This clearly indicated the origin of the contamination which was

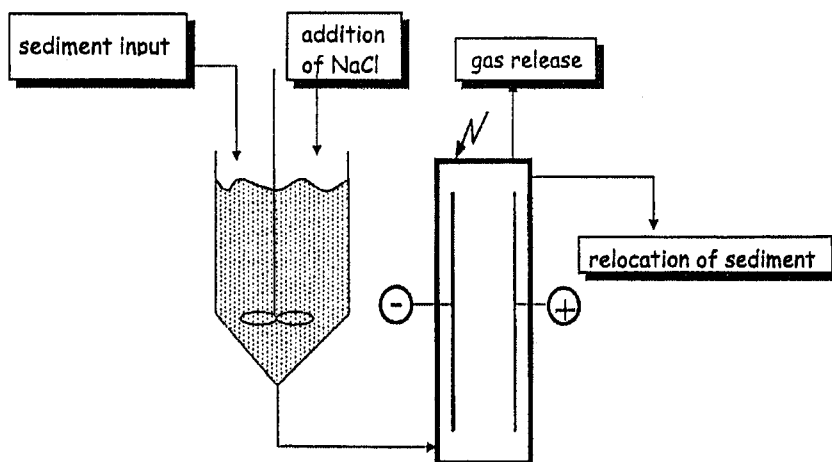

Fig. 1: Scheme showing the process for slurry electrolysis.

Prozessschema der Suspensions-elektrolyse.

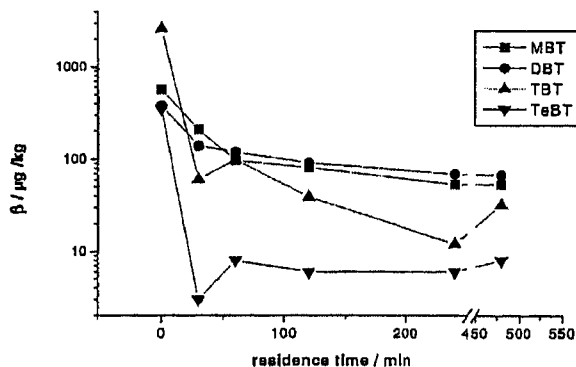

Fig. 2: Electrochemical decomposition of butyltin compounds in sediments.

Elektrochemische Zerstörung von Butylzinnverbindungen In Sedimenten.

not caused by agricultural input in the Elbe River or any other diffuse sources, but based on the use of antifouling paintings on submerged ship surface. In non-optimised experiments conducted in a technical scale, the butyltin concentrations could be reduced in the dredged material from 350 µg/kg to

<10 µg/kg TeBT, from 2600 µg/kg to <30 µg/kg for TBT, 380 µg/kg to <100 µg/kg for DBT, and from 570 µg/kg to <100 µg/kg for MBT, respectively. All butyltin compounds could be destroyed by means of electrochemical sediment treatment below the relocation criteria in Germany of <100 µg/kg.

TeBT and TBT, which show a stronger +I-effect are decomposed faster than DBT and MBT. The decomposition of the pollutants occurs due to electrophilic attack of oxidising species, e.g. hydroxyl radicals, hypochlorite, ozone which are generated electrochemically. It is well known that those generated species react favourably with electron-rich compounds [20, 21 and cited publications therein]. So our hypothesis stays in good agreement with the common knowledge of electrochemical oxidation of organic compounds. The real mechanism cannot be investigated in such multi-component systems. Further investigations with model systems will have to be undertaken to elucidate the mechanism. The results of the electrochemical butyltin decomposition are depicted in Figure 2.

Next to TBT, we have investigated 16 PAH in the sediment before and after electrochemical treatment. All PAH are present in the dredged material. An overall decomposition rate of approximately 90% could be achieved; this is reflected by the sum of all PAH, which are reduced from 4.1 mg/kg to

Table 2: Mass fractions of PAH in the sediment.

Massenanteil der PAK im Sediment.

Mass fraction, mg/kg	Residence time			
	t = 0 min	t = 30 min	t = 60 min	t = 120 min
Naphthalene	0.23	0.67	0.54	0.18
Acenaphthylene	0.05	<0.03	<0.03	<0.03
Acenaphthene	0.06	<0.03	<0.03	<0.03
Fluorene	0.13	0.03	0.03	<0.03
Phenanthrene	0.48	0.10	0.08	0.05
Anthracene	0.16	0.04	0.03	<0.03
Fluoranthene	0.60	0.13	0.10	0.06
Pyrene	0.51	0.08	0.06	0.04
Benz[a]anthracene	0.28	0.06	0.04	<0.03
Chrysene	0.34	0.08	0.06	0.04
Benzo[b]fluoranthene	0.41	0.10	0.07	0.04
Benzo[k]fluoranthene	0.17	0.09	0.05	<0.03
Benzo[a]pyrene	0.28	0.05	<0.03	<0.03
Indeno[1,2,3-cd]pyrene	0.15	0.04	<0.03	<0.03
Dibenzo[a,h]anthracene	0.09	<0.03	<0.03	<0.03
Benzo[ghi]perylene	0.17	0.04	<0.03	<0.03
Sum PAH	4.1	<1.6	<1.2	<0.53

0.53 mg/kg. The concentrations of the PAH are shown in Table 2. The electrochemical degradation is not uniform for the single PAH and for most of the compounds degradation occurs within the first 30 min of the treatment. Naphthalene is an exception, which is perhaps due to its occurrence as intermediate

product of the electrochemical degradation process of other PAH. At the beginning of the treatment, the naphthalene concentration increases from 0.23 mg/kg to 0.67 mg/kg but decreases afterwards to 0.18 mg/kg. So not just TBT but all PAH are decomposed during the electrochemical sediment treatment.

Table 3: Mass fractions of PCB in the sediments versus treatment time.

Massenanteil der PCB im Sediment in Abhängigkeit von der Behandlungszeit.

Mass fraction, µg/kg	t = 0 min	t = 30 min	t = 60 min	t = 120 min	t = 240 min
PCB 31	3.9	5.2	3.4	2.4	2.4
PCB 28	3.4	3.7	4.0	2.8	2.0
PCB 52	7.1	7.4	9.4	6.2	4.0
PCB 10	17.4	10.8	9.7	8.0	n.d.
PCB 153	11.6	16.2	17.1	16.3	14.1
PCB 138	12.2	16.1	17.9	16.2	15.6
PCB 180	7.9	12.7	13.0	12.7	11.2

Table 4: Pesticides and chlorobenzenes before and during the treatment.

Massenanteil an Pestiziden und Chlorbenzolen vor und während der Behandlung.

Mass fraction, µg/kg	t = 0 min	t = 30 min	t = 60 min	t = 120 min
1,3,5-Trichlorobenzene	3.2	5.7	6.1	3.3
1,2,4-Trichlorobenzene	5.8	17.3	1.4	2.6
1,2,3-Trichlorobenzene	4.6	20.3	18.3	7.5
1,2,4,5-Tetrachlorobenzene	2.8	n.d.	n.d.	n.d.
1,2,3,4-Tetrachlorobenzene	0.7	n.d.	n.d.	n.d.
Pentachlorobenzene	3.4	5.5	4.3	3.1
Hexachlorobenzene	16.1	31.4	29.4	19.1
α-HCH	0.2	0.2	0.2	0.2
β-HCH	0.6	0.6	0.6	0.6
γ-HCH	0.4	0.4	0.4	0.4
Heptachlor	0.9	5.7	2	0.8
Aldrin	0.4	0.4	0.4	0.4
Heptachlorepoxyd B	0.5	0.4	0.4	0.4
α-Endosulphone	13.1	2.2	1.8	1.7
β-Endosulphone	17.8	25.6	26	23
Dieldrin	0.6	0.8	0.6	0.6
Endrin I	8.5	12.6	13.5	10.1
Endrin II	7.6	9.6	9.2	9
2,4-DDE	1.9	n.d.	n.d.	n.d.
4,4-DDE	13.1	5.5	3.7	3.7
2,4-DDD	8.5	16.2	11.5	11.5
4,4-DDD	0.8	0.6	0.6	0.6
2,4-DDT	0.9	0.8	0.8	0.8

n.d.: not determined.

PCB are another important pollutant class in sediments. Seven PCB are investigated in agreement with the list of orientation values for sediment relocation. The results are presented in Table 3. Auxiliarily chlorobenzenes and pesticides are analysed. The results are shown in Table 4.

Significant change in concentrations of pollutant compared with naturally occurring variations due to sediment heterogeneity in the investigated area could not be observed. Furthermore the presence of elementary sulfur in the samples causes overlaps in the spectra. Therefore 2,4-DDE, 1,2,3,4-tetrachlorobenzene and 1,2,4,5-tetrachlorobenzene could not be detected in the treated sediments. There are weak indications that α -endosulphone will be decomposed too and that perhaps chlorinated benzenes, like trichloro- and hexachlorobenzene will be formed and afterwards decomposed within the treatment process (see Table 4).

4 Conclusions

The target value for relocation of sediments in Germany of <100 $\mu\text{g}/\text{kg}$ TBT is achieved with the presented process. Furthermore other chemical criteria like PAH and PCB concentrations are investigated. While the PAH are decomposed simultaneously as well as organotin compounds the PCB concentrations remain the same. The degradation rate for PAH is approximately 90%. Former studies have shown that the concentrations of heavy metals and their mobility are not influenced by the treatment. Process conditions have to be controlled very carefully, because simultaneously to the electrochemically induced pollutant degradation other sediment ingredients can react with the electrochemical generated radicals and form by-products which might be undesirable.

In addition to the chemical analysis bioassays should be applied to prospect undesired effects. Chemical analysis is a strong tool in assessing the main target of decontamination processes, but advanced process optimisation should also include effect studies if the treated material is supposed to release into the environment again.

A pilot plant was installed and is operated in Bremen in cooperation with the harbour authorities of Bremerhaven.

Acknowledgements

The research was carried out in the Technical University Hamburg-Harburg in cooperation with Strom- and Hafengebäude Hamburg and Hanseatisch-Bremisches Hafenamts Bremer-

haven. PAH and PCB were analysed by Dr. M. Reich from the central laboratory of the TUHH. The work is additionally funded by the EU-LIFE program within the project "New approach to an integrated electro-TBT-detoxification of dredged material on a pilot-scale".

References

- [1] Evans, S. M.: Tributyltin pollution: the catastrophe that never happened. *Mar. Pollut.* **38**, 629–636 (1999).
- [2] de Mora, S. J.: Tributyltin: Case Study of an Environmental Contaminant. Cambridge University Press, Cambridge, 1996
- [3] Schwarz, S., Pachur, H. J.: Organozinnverbindungen in Sedimenten und Schwebstoffen Berliner und Brandenburger Seen. In Huch, M. (Ed.): Umweltgeochemie in Wasser, Boden und Luft. Springer, Heidelberg, 2001, pp. 75–95
- [4] Solé, M., Morcillo, Y., Porte, C.: Imposen in the commercial snail *Bollnus brandaris* in the northwestern Mediterranean. *Environ. Pollut.* **99**, 241–246 (1998).
- [5] Porte, C., Morcillo, Y.: Evidence of endocrine disruption in clams – *Ruditapes decussata* – transplanted to a tributyltin-polluted environment. *Environ. Pollut.* **107**, 47–52 (2000).
- [6] Rouleau, C., Gobell, C., Tjälve, H.: Pharmacokinetics and distribution of dietary tributyltin and methylmercury in the snow crab. *Environ. Sci. Technol.* **33**, 3451–3457 (1999).
- [7] Harino, H., Fukushima, M., Yamamoto, Y., Kawai, S., Miyazaki, N.: Contamination of butyltin and phenyltin compounds in the marine environment of Otsuchi Bay, Japan. *Environ. Pollut.* **99**, 209–214 (1998).
- [8] ENDS (Environment daily, <http://www.environmentdaily.com/articles>) 21/08/00.
- [9] ENDS (Environment daily, <http://www.environmentdaily.com/articles>) 24/01/01.
- [10] ENDS (Environment daily, <http://www.environmentdaily.com/articles>) 08/02/01.
- [11] Simond, O., Schaller V., Comninellis, Ch.: Theoretical model for the anodic oxidation of organics on metal oxide electrodes. *Electrochim. Acta* **42**, 2009–2012 (1997).
- [12] Fryda, M., Herrmann, D., Schäfer, L., Klages, C.-P., Perret, A., Haenni, W., Comninellis, Ch., Gandini, D.: Properties of diamond electrodes for wastewater treatment. *New Diam. Front. Carbon Technol.* **9**, 229–240 (1999).
- [13] Stichnothe, H., Thömling, J., Calmano, W.: Detoxification of tributyltin contaminated sediments by an electrochemical process. *Sci. Total Environ.* **266**, 265–271 (2001).
- [14] Schürmann, U., Gründler, P.: Electrochemical degradation of organic substances at PbO_2 anodes: Monitoring by continuous CO_2 measurements. *Water Res.* **32**, 2835–2842 (1998).
- [15] Panizza, M., Bocca, C., Carlsola, G.: Electrochemical treatment of wastewater containing polyaromatic organic pollutants. *Water Res.* **34**, 2601–2605 (2000).

- [16] *Stichnothe, H., Thömling, J., Calmano, W.*: Decomposition of tributyltin (TBT) from contaminated sediments. International meeting on "Contaminated sites assessment and remediation: New perspectives", Milano, 2000, pp. 148-151.
- [17] *Stichnothe, H., Thömling, J., Calmano, W.*: Decomposition of organotin in dredged material from harbours by means of an electrochemical process. *Aquat. Ecosyst. Health Manage.* (2002), in press.
- [18] *Comninellis, Ch., Nerini, A.*: Anodic treatment of phenol in the presence of NaCl for wastewater treatment. *J. Appl. Electrochem.* 25, 23-28 (1995).

- [19] *Kraft, A., Stadelmann, M., Blascke, M., Kreysig, D., Sandt, B., Schröder, F., Renau, J.*: Electrochemical water disinfection Part I. *J. Appl. Electrochem.* 29, 861-868 (1999).
- [20] *Mailhot, G., Astruc, M., Bolte, M.*: Degradation of tributyltin chloride in water photoinduced by iron(III). *Appl. Organomet. Chem.* 13, 53-61 (1999).
- [21] *Kruk, J.*: *Environmental Toxicity and Chemistry of Oxygen Species.* Springer, Berlin, 1998.
- [22] Anonymous, *Strom- und Hafenbau Hamburg.*

[Received: 14 September 2001; accepted: 19 April 2002]

Die aktualisierte Neuauflage

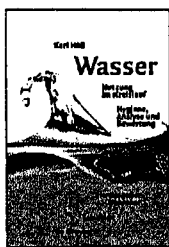

Karl Höll

■ Wasser

Nutzung im Kreislauf, Hygiene, Analyse und Bewertung
8., völlig neu bearbeitete Auflage

herausgegeben von Andreas Grohmann
2002, XXVII, 952 Seiten. 105 Abbildungen. 124 Tab.
€ 88,- [D] / sFr 141,- / approx. US\$ 88.00
ISBN 3-11-012931-0

Das von Karl Höll begründete, zu einem Standardwerk für Wasserfachleute herangereifte Werk, erscheint in der 8. Auflage in einer durchgängig aktualisierten Form. Sein Charakter als Nachschlagewerk und Laborhandbuch für Praktiker bleibt dabei unverändert erhalten.

Neben einem breiten Überblick zu hydrogeologischen, chemischen und mikrobiologischen Aspekten bietet das Werk ausführliche Informationen zu modernen chemischen und biologischen Verfahren der Wasseranalytik, nebst einer Beschreibung der hierfür benötigten Ausrüstung. Praktische

Aspekte der Aufbereitung, Desinfektion und Verwendung von Wasser sowie der Abwasserreinigung werden ebenfalls ausführlich und auf aktuellstem Niveau behandelt.

Aus dem Inhalt:

Einleitung · Hydrogeologie · Chemie des Wassers · Toxikologie · Bakteriologie · Virologie · Biologie · Aufbereitung · Schutz vor Krankheitserregern · Befund und Bewertung · Verwendung von Wasser · Bäder und Kleinfadeteiche · Abwasserreinigung · Anhang · Register

**W
DE
G** de Gruyter
Berlin · New York

www.deGruyter.de

WALTER DE GRUYTER GMBH & CO. KG · Genthiner Straße 13 · 10785 Berlin
Telefon +49-(0)30-2 60 05-0 · Fax +49-(0)30-2 60 05-251 · E-mail wdg-info@deGruyter.de

Bitte bestellen Sie bei Ihrer Buchhandlung oder
direkt beim Verlag. Preisänderungen vorbehalten

Annex 5: Fletcher L.E. & Lewis J.A.:
*Regulation of shipyard discharges in Australia and the potential of UV
oxidation for TBT degradation in washdown waste water*
Proceedings of Oceans '99 Congress, p. 27 - 35

Regulation of Shipyard Discharges in Australia and the Potential of UV Oxidation for TBT Degradation in Washdown Waste Water

Lyn E. Fletcher¹ and John A. Lewis²
E-Mail: john.lewis@dsto.defence.gov.au

ABSTRACT

The Royal Australian Navy uses tributyltin (TBT) antifouling paints on the major ships in its fleet. Tributyltin compounds are very effective antifoulants but have proven to be harmful to many marine organisms, and effects to non-target species have been observed in Australian inshore waters. Consequently, the use of these paints and release of tributyltin compounds into the environment have been regulated in many countries, including Australia. In Australia the regulation of TBT has been the responsibility of the individual states but it is now government policy to implement a total ban on antifouling paints containing TBT. The release of TBT contaminated wastes from shipyards and other vessel repair facilities is also coming under increasing regulatory control.

One major source of contamination is the water used to wash down ship hulls when vessels dock for repainting or refit. DSTO in collaboration with other commercial partners has been developing technologies to treat this TBT contaminated water. Contaminated wash down water has been demonstrated to be treatable using enhanced oxidation techniques. These processes produce hydroxyl radicals, which destroys tributyltin compounds by progressively converting them to much less toxic di-butyl tin, mono-butyl tin and eventually to inorganic tin compounds. Turbidity has been shown to significantly interfere with the process and trials are continuing to assess the level and type of pretreatment required.

Keywords: Tributyltin, TBT, antifouling paints, photodegradation, photocatalysts, enhanced oxidation

INTRODUCTION

Tributyltin (TBT) compounds are broad spectrum biocides used in many antifouling paints to prevent the growth of marine fouling on ship hulls. These antifouling paint systems work by slowly and continually releasing a controlled amount of TBT which is toxic to most common fouling organisms. Once released into the environment, TBT readily partitions into sediments and the surface microlayer or is degraded in the water column with a half life of around 6 days. The half life of TBT in sediments is estimated to be 3.5 years (Batley, 1995). Consequently, TBT can be quite persistent in the marine environment.

TBT readily bioaccumulates and is extremely toxic to many non-target marine organisms. Important commercial species such as oysters and other bivalves have been adversely affected by TBT pollution. The NOEL (no observable effect level) of TBT for oyster larvae has been found to be as low as 20 ng/l, with considerable mortality occurring at 50 ng/l (Alzieu, 1991). In addition, the development of male characteristics on females, termed imposex, is thought to be induced in European mud whelks (marine snails) by TBT concentrations as low as 1 ng/l (Lewis, 1998). In Australia, shell abnormalities attributable to TBT have been observed in Pacific oysters in Tasmania and Sydney rock oysters in New South Wales (Batley & Scammell, 1991). Imposex has been detected in various

¹ Aeronautical and Maritime Research Laboratory, Defence Science and Technology Organisation, GPO Box 4331, Melbourne 3001, Australia, Tel: (+61) (3) 9626-8422, Fax: (+61) (3) 9626-8999, E-Mail: lyn.fletcher@dsto.defence.gov.au

² Aeronautical and Maritime Research Laboratory, Defence Science and Technology Organisation, GPO Box 4331, Melbourne 3001, Australia, Tel: (+61) (3) 96-26-8418, Fax: (+61) (3) 9626-8999, E-Mail: john.lewis@dsto.defence.gov.au

gastropod species in Western Australia (Kohn & Almasi, 1993), South Australia (Nias *et al.*, 1993), Victoria (Foale, 1993) and New South Wales (Wilson *et al.*, 1993). In coastal waters near Perth, Western Australia, widespread contamination of TBT in the waters and sediments of the study area and the widespread occurrence of imposex in the gastropod mollusc *Thais orbita* were considered to indicate that TBT contamination of the coastal waters was an issue of extreme concern (DEP, 1996).

What exacerbates the problem, is that oyster beds and harvesting areas for many commercial species are often situated in bays, estuaries, and lagoons near harbours and marinas with high densities of pleasure craft and ships (Alzieu, 1991). High concentrations of TBT also occur near ship repair and drydock facilities (Lewis, 1993). Consequently, stringent limits for the use of TBT antifouling paints have been established which, in many Western countries, effectively prohibits the use of TBT antifouling paints on vessels less than 25 m in length (Batley, 1995). Regulations have also been imposed on land based operations to minimise TBT discharges into the marine environment. Further to this, at its meeting in November 1998, the Marine Environment Protection Committee (MEPC) of the International Maritime Organisation (IMO) resolved to implement a global ban on the application of paint containing TBT by 1 January 2003 and to a complete ban on the presence of TBT on ship hulls by 1 January 2008.

AUSTRALIAN POLICIES ON TBT

In Australia, regulation of the use of TBT antifouling paints has been the responsibility of the individual Australian States. The issues associated with the use of TBT in the Australian and New Zealand environment achieved prominence in early 1988 when detailed assessments of the use of antifoulants containing organotins were undertaken in New South Wales (Maltz, 1998) and New Zealand (Ministry for the Environment, 1988), and a conference was held to consider the Australian situation (Holmes, 1988). The issues were also addressed in New Zealand at around the same time. It was soon after this that Tasmania became the first Australian State to restrict the use of TBT, requiring all antifouling paints to be registered and imposing a ban on the use of antifouling paints

with a TBT release rate greater than 4 $\mu\text{g}/\text{cm}^2/\text{day}$. In early 1989, New South Wales introduced more stringent controls which banned the application of TBT antifouling paints to vessels less than 25 m in length. Other States followed suit using various statutory mechanisms.

As an example, in Victoria, the *Environment Protection (Organotin Antifouling Paint) Regulations 1989* were introduced under the *Environment Protection Act 1970*. These regulations stipulated that "a person must not use organotin antifouling paint on or apply it to or cause or permit it to be used on or applied to- (i) a ship which is 25 metres or less in length; or (ii) a pier, buoy, mooring or any other structure in marine or estuarine waters". Further, it stipulated that "a person must not use organotin antifouling paint or apply it to or cause or permit it be used on or applied to a ship that is more than 25 metres in length except with the prior written consent of the Authority." At the same time, proclamations were made under the *Agricultural Chemicals Act 1958* to prescribe tributyl tin to be prohibited for use as an agricultural chemical except where written consent was given by the Environment Protection Authority and to "declare the standard for tributyltin to be a maximum leaching rate into water of 5 micrograms per square centimetre per day of tributyltin from painted surfaces". These regulations sunsetted on 1 June 1999 and are proposed to be replaced by a *Notifiable Chemical Order for Organotin Antifouling Paint* (Bezzobs, 1999).

New South Wales, Victoria, Queensland, Western Australia and the Northern Territory all enacted controls limiting the use of TBT paints to vessels greater than 25 m in length and with release rates greater than 5 $\mu\text{g}/\text{cm}^2/\text{day}$. Tasmania and South Australia restricted the release rates only; no greater than 4 $\mu\text{g}/\text{cm}^2/\text{day}$ in Tasmania, and 5 $\mu\text{g}/\text{cm}^2/\text{day}$ in South Australia. The US EPA Method was accepted in all states as the method for determining TBT release rates (US EPA, 1996). The Royal Australian Navy (RAN) policy is generally to use TBT antifouling paints only on HMA Ships over 40 m in length (RAN, 1994).

Moves to achieve national consistency in the management of TBT were initiated in 1989 when the Environment Council, a forerunner of the present Australian and New Zealand Environment and

Conservation Council (ANZECC), set up an *ad hoc* working group to investigate the issues. Members of the Council include State and Federal Government Environment Ministers from both Australia and New Zealand. In 1992, as part of a broader examination of the environmental aspects of shipping, the Council established a Maritime Accidents and Pollution from Shipping Task Force. This prepared a strategy, after extensive consultation, that sought to coordinate actions on all possible impacts from shipping (ANZECC, 1996a, b, c). In regard to antifouling practices, the strategy included the following objective:

“Recognising that antifouling practices have improved in recent years, promote improved standards and best practice, and development and use of more environmentally benign antifouling practices by:

- (i) adopting in general the IMO resolutions as the basis for Australian and New Zealand law, pending further review, to:
 - (a) eliminate the use of antifouling paints containing organotins (normally tributyltin or TBT) compounds on non-aluminium vessels of less than 25 metres in length;
 - (b) eliminate the use of anti-fouling paints containing TBT compounds that release more than 5 micrograms of organotin per square centimetre per day;
 - (c) develop management guidelines for ship maintenance and construction facilities to prevent the release of TBT compounds into the marine environment from maintenance and construction facilities and run-off;
 - (d) encourage the development and use of alternatives to TBT formulations that have minimal non-target effects;
 - (e) conduct monitoring to evaluate effectiveness of adopted measures;
 - (f) share information with interested parties;
- (ii) supporting, as required, the review of the ambient standards for TBT in ANZECC’s Australian Water Quality Guidelines (ANZECC, 1992);
- (iii) monitoring and reporting on progress in introducing more environmentally friendly

- antifouling practices; and
- (iv) reviewing overall progress every two years.”

An outcome of this strategy was the completion of a consultancy which developed recommendations for:

- (a) a draft code of practice for application, use removal and disposal of antifoulants and the fouling material
- (b) a draft scheme for classification of marine protective coatings including antifoulants, and
- (c) generic principles for assessing effects of antifoulants.

In late 1998 the Australian Government released the *Australia’s Oceans Policy* (Anon. 1998a, b) with the position that the Government will:

- ban the use of tributyltin (TBT) antifouling paint by 2006 on vessels being repainted in Australian docks, unless the International Maritime Organization sets an earlier date for such a ban, in which case Australia will ensure it complies with any such arrangements noting Defence’s operational requirements; and
- continue to promote the introduction of a global ban on TBT through the International Maritime Organisation.

AUSTRALIAN POLICIES ON DOCKYARD DISCHARGES

Australian States with controls over discharges have implemented these by requiring that shipyards and slipways are licensed, and imposing relevant conditions on the licence, Queensland was the first State to licence facilities to specifically address the issue of organotin wastes. The chemical control order specified that “a person could not use the chemical tributyltin other than at a place approved by the Minister”. Approval of premises for the use of TBT based antifouling paints required:

- existence of a holding facility of a capacity to contain all water from the work area, including first flush stormwater;
- provision of suitable bund walls around areas where paint removal and application are to take

- place to direct waste water to the holding facility;
- all first flush stormwater to be directed into the holding facility and to be prevented from entering the waterway
- provision of a lid over the holding facility to prevent excess rainwater from entering the pit during periods of major rainfall which may otherwise cause the pit to overflow, or alternatively an automatic facility to bypass the excess stormwater
- stormwater originating from outside the TBT work area to be diverted away from the work area
- work area to be totally above the limit of tidal influence
- techniques to be used which minimise aerial distribution of waste, ie low pressure water blasting and sponging (or wet slurry blasting) in preference to sand blasting; airless spray guns in preference to compressed air guns
- screens or enclosures to be used to minimise the aerial distribution of TBT

Other States are yet to enact similar controls, although New South Wales now requires that shipyards have a plan in place to contain, treat and/or dispose of contaminated wastes. In Victoria, the discharge of contaminated wastes is restricted under the general provisions of the Environment Protection Act which prohibits the discharge of any polluting material into waterways. In South Australia, the policy for licensing discharges specifies a maximum release rate of 5 µg tributyltin per cm² per day as a criteria for the protection of shellfish growing areas (EPCSA, 1992).

However, once contained, the wastes still have to be disposed of in an acceptable manner. TBT contaminated wastes are generally classified as prescribed wastes. This means that transport and disposal are subject to strict regulation. Depending on the waste, acceptable management options can include physico-chemical or biological treatment, incineration, immobilisation or, for solids and residues, landfill at approved sites. Liquid wastes can often be discharged to sewer after appropriate treatment, with the permission of the local sewerage authority.

A strong emphasis on reducing the amount of any prescribed waste at source is encouraged, and the economic expense of transport and offsite disposal of

prescribed waste is further encouragement for such an approach. There is therefore a clear need for new treatment methods and processes to remediate TBT contaminated wastes.

As previously mentioned, one outcome of the ANZECC Maritime Accidents and Pollution from Shipping Task Force was the development of a draft code of practice for the application, maintenance, removal and disposal of antifouling paints. This code proposes that the application, maintenance and removal of all antifouling coatings should only be done at facilities capable of meeting New Zealand and Australian State, Territory and Commonwealth regulatory requirements for dangerous goods, occupational health and safety and environmental protection, and appropriate standards of best practice. Further, it proposes that Australia and New Zealand should work toward uniform licensing procedures for such facilities and that the sale of antifoulants should be restricted to these facilities.

For new facilities, the code proposes that "no water should run off work areas without treatment to remove toxic substances, turbidity and discolouration. New facilities should be designed and managed so as to allow for eventual disposal to sewer of treated waste water and first-flush runoff. The acceptable standards and quality of water for disposal into sewer would come under the jurisdiction of the local sewerage authority.

For existing drydocks, slipways and hardstands, the code proposes that "measures should be adopted to minimise water runoff and certain potentially toxic, turbid or discoloured discharges. Bunds may be used on sealed concrete, sumps to contain waste water and spillages, and strawbales and woven fibre material to retain suspended solids. Existing facilities should plan for upgrading to allow for eventual disposal to sewer of waste water and first-flush runoff.

The draft code of practice is still, as designated, a draft and is yet to be discussed in detail within ANZECC. Implementation is therefore still somewhat off. In the interim, control over discharges from ship and boat yards in Australia remains the responsibility of the States and subject to their will and initiative.

ENHANCED OXIDATION OF TBT CONTAMINATED SHIPYARD WASTE WATERS

During the operational life a ship, whenever it is drydocked, and prior to repainting, the underwater hull requires washing or hydroblasting to remove the biological slime and hydrolysed surface layer of the paint. This generates significant quantities of TBT contaminated waste water. TBT concentrations in washdown waters can exceed 5 mg/l, but are usually within the $\mu\text{g/l}$ range. Where discharge has been permitted into adjacent waterways, discharge limits significantly below this have been set, for example 30 ng/l for one Australian facility. Disposal into sewer can also require a reduction in TBT concentrations and, if neither discharge is permissible, the cost for transport and disposal off-site can be high. Consequently, there is a need to find treatment methods that can reduce TBT concentrations to levels that are below the discharge limits.

Traditional biological treatment processes are not readily compatible with these wastes because of the extreme toxicity of TBT to many microorganisms. However, studies have shown that TBT compounds are susceptible to photodegradation. In a three-month study, Duhamel et al. (1987) showed that when tributyltin chloride and tributyltin oxide solutions were placed in sunlight, the TBT compounds were degraded, producing dibutyltin (DBT), monobutyltin (MBT), inorganic tin, and some polymeric organotins. Similarly, Komora and Popl (1978), using UV irradiation of tributyltin oxide found the same products after 24 hours illumination. Photodegradation, therefore, appears to be a promising technique to treat TBT contaminated wastewaters. Advanced oxidative techniques that produce hydroxyl radicals, a powerful oxidant, are methods whereby the rate of photodegradation may be enhanced.

DOCKYARD PROCESSES

In Australia there are three types of docks that are of a concern: dry docks, slipways and floating docks, and each will require different collection and holding facilities for both waste waters and abrasive blasting grits. It is anticipated that not all shipyards will be

able to meet future requirements, and these dockyards will either close or restrict their operations to non-TBT painted hulls.

Washdown wastewaters from these dockyards vary enormously. The measured TBT concentrations have been found to range from 5 $\mu\text{g/l}$ to 8 mg/l. The highest TBT concentration was recorded at a Victorian slipway, which was using a hydroblast pressure of 10,000 psi. In this case, large proportions of anti-fouling paint were being removed during hydroblasting. This is an extremely high value and includes both particulate and dissolved TBT. The washdown water from this slipway also contained dibutyltin (270 $\mu\text{g/l}$) and monobutyltin (42 $\mu\text{g/l}$). This indicates that degradation of the TBT antifoulant is already occurring on painted and fouled surface.

It was also noted that at high hydroblasting pressures (in this case 10,000 psi) aerosol formation is also a significant environmental problem. This aerosol dispersion is difficult to trap and collect at present, and improvements here will depend on the design of improved hydroblasting equipment. However, a system designed to collect first flush stormwater will help contain some of this aerosol.

Dockyard washdown wastewaters are generally collected as run-off from the dock surface. During this, the waste will have ample opportunity to collect dockyard debris and other contaminants from the dock's other activities. It has been noted that oil and grease may also be significant components of stored washdown wastewater. Therefore, the final washdown wastewater that requires treatment will be quite a non-uniform and complex waste.

PRINCIPLES OF ENHANCED OXIDATION

Due to the toxic nature of TBT, a non-biological method was sought which could destroy TBT and minimise the contaminated wastes to go to landfill. Enhanced oxidation appears to meet these objectives. Enhanced oxidation is a term given to a number of technologies that produce hydroxyl radicals. Hydroxyl radicals are very powerful oxidants that can react quickly and vigorously with a wide number of chemical substrates.

Some of the more common enhanced oxidation techniques are listed below. Those with asterisks are the techniques DSTO assessed in the laboratory for treating TBT.

- Photocatalysis* uses visible light to excite a photocatalyst, the most common being the Anatase form of titanium dioxide. It has the advantage of using a cheap source of energy source (sunlight) but the reaction is limited to the surface, and reactor design is quite complex.
- Electrolytic oxidation uses similar semiconducting materials as the photocatalysis method, but the semiconductor material is excited electrochemically.
- UV/Oxidation* is another technique gaining favour. It uses 256 nm UV light to react with either ozone or hydrogen peroxide, which through various chain reactions produces the hydroxyl radical. The disadvantages are the higher cost of energy, but scaling up to a commercial unit is simpler.
- Fentons reagent uses a mixture of iron salts and oxidants.

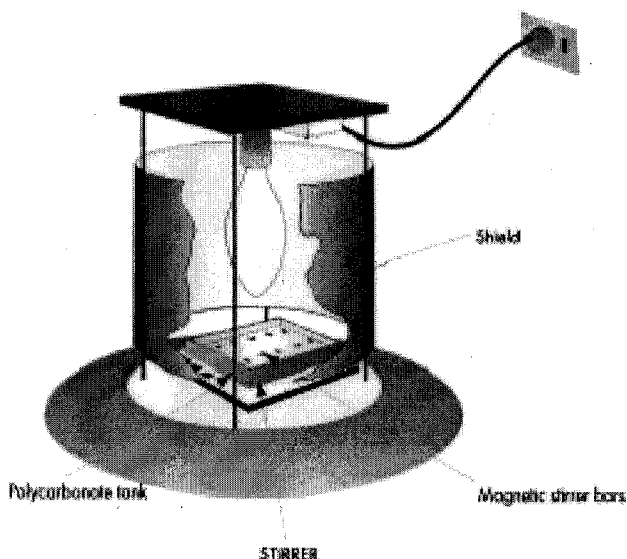

Figure 1. Schematic Diagram of the photochemical Test rig.

PHOTOCATALYTIC OXIDATION: METHOD

The photoreactor used for the experiments consisted of a 500 Watt mercury arc lamp which was suspended over a shallow polycarbonat tank measuring 300 x 150 x 70 mm (Figure 1). The tank and light were shielded with polished metal to reflect light into the centre of the photoreactor. The visible light intensity within the tank ranged from 340-720 $\mu\text{Es}^{-1}\text{m}^{-2}$, which is approximately a quarter of the intensity of sunlight. The contents of the tank were stirred with a multi-position magnetic stirrer. Sampling was done at various time intervals with the lights off. The samples were promptly wrapped in foil and frozen until analysis.

Titanium dioxide in Anatase form was obtained from Kodak. Prior to use, the titanium dioxide was heated to 550 °C for 30 minutes following the method of Matthews (1983). Polycarbonat and teflon were the only materials in contact with the test solutions.

Organotins were analysed with a Varian Star 3400 gas chromatograph with flame photometric detector. TBT acetate was converted to TBT hydride by extracting 50 ml of sample with 5 ml of analytical grade hexane, 2 ml of a 4 % w/v sodium borohydride solution and spiked with a tripropyltin chloride internal standard (Tsuda *et al.*, 1986). The solution was shaken for 30 minutes. The separated hexane fraction was then concentrated by gently blowing nitrogen gas over the solution. During the extraction procedure the suspended titanium dioxide remained in the water phase and did not interfere with the separation. The detection limit was found to be 10 $\mu\text{g/l}$. Standard curves were obtained by adding varying amounts of a stock solution of tributyltin acetate, dibutyltin dichloride and monobutyltin trichloride in methanol, to 50 ml of deionised water and extracting using the same method as the samples.

PHOTOCATALYTIC OXIDATION: RESULTS

The result shown in Figure 2 is a typical example of the change in organotin concentrations with time, and the results obtained are consistent with a sequential dealkylation degradation pathway, where tributyl tin

is converted to dibutyl tin, then monobutyl tin, and eventually inorganic tin. Consequently, the hydroxyl radical is reacting at the tin-carbon bond and removing one butyl group each time. Importantly, the toxicity of the resultant product is reduced during each dealkylation stage. Therefore, complete mineralisation to inorganic tin will not be necessary to significantly reduce the toxicity of the effluents.

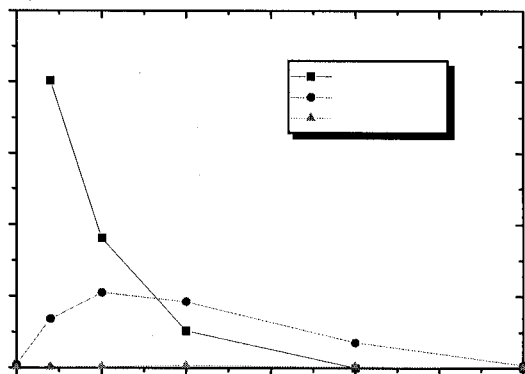

Figure 2 Typical Reaction Pathway

Another element of the observed reaction is that it is pseudo first order in character (Figure 3). Therefore, it is possible to calculate a reaction half-life for each experiment based on the slope of the line. This holds for all of the enhanced oxidation techniques so far tested with TBT. It also allows for easy comparisons, and for individual process optimisation.

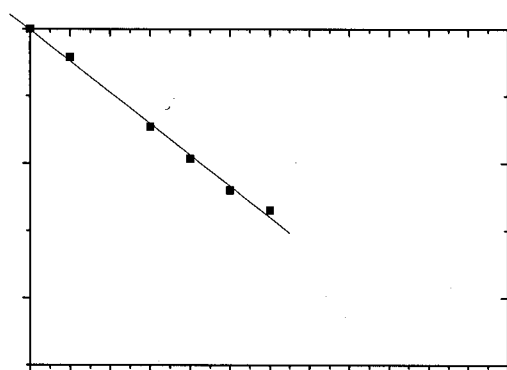

Figure 3 Pseudo first order reaction rate measured at pH = 9.3, titanium dioxide concentration of 1.0 g/l. The measured half-life in this instance is 7.4 minutes.

The photocatalytic oxidation experiments produced results that were pH dependent. This is not surprising given that hydroxide can readily be converted to the hydroxyl radical by the photocatalyst. Table 1 summarises the results obtained using a model TBT waste water in the photocatalyst test rig.

These results demonstrate that the process does not provide a useful rate of reaction until the pH is around 12.6. This is going to be a major disadvantage for any meaningful process scale-up. Consequently, the decision was made to assess another enhanced oxidation technique.

Table 1. Photocatalysis of 2.5 mg/l tributyltin acetate in deionised water, using 2.0 g/l TiO₂, 380 nm UV light and pH adjusted using NaOH and HCl.

pH	Half life (minutes)
5.5	24.8
7.5	19.6
9.3	7.4
10.7	5.0
12.6	2.7

UV/OXIDATION: METHOD

UV/oxidation was assessed as having a number of advantages that made its investigation worthwhile. Firstly, unlike photocatalysis, the reaction is not confined to a surface and hence there is greater potential to maximise the amount of hydroxyl radical available to the process. In addition, because the reaction is not restricted to a surface, scale up to a commercial scale continuous process would be less technically challenging.

The UV/oxidation test-rig used in the following experiments was similar to the one for photocatalysis (Figure 1), but a 256 nm UV light was used to illuminate the test mixture and the shape of the rig was altered to maximise light penetration. The test mixtures included pure TBT in deionised water, used for optimisation trials, and samples of collected dockyards washdown wastewaters. Hydrogen peroxide was added prior to illumination and again samples were taken at regular intervals and stored for later analysis. Initial blank experiments were performed using only UV light and only hydrogen peroxide. Neither of these experiments

produced a significant reaction rate with TBT. This confirms that the active process observed in subsequent experiments was hydroxyl radical formation and reaction with TBT.

Organotin concentrations in the test mixtures were determined using the same method as in the photocatalytic oxidation experiments.

UV/OXIDATION: RESULTS

Initial results showed that UV/Oxidation has the same reaction pathway as the one observed for photocatalytic oxidation (Figure 1). This was expected, as the underlying reaction is the same, hydroxyl radical oxidation of the tin-carbon bond. In addition the pseudo first order reaction kinetics were again observed.

To optimise the process, the effect of hydrogen peroxide concentration was assessed. Table 2 summarises the initial investigation of the UV/oxidation process using TBT acetate dissolved in deionised water with varying amounts of 42% hydrogen peroxide. The reaction half-lives observed for UV/oxidation are at least one order of magnitude faster than the results obtained using photocatalysis (Table 1).

The optimum rate of hydrogen peroxide dosing is around 0.3 ml/litre of standard 42% hydrogen peroxide. This would mean that 1 litre of hydrogen peroxide would be needed to treat each 3,000 litres of waste. The volume of waste washdown water produced varies with size of the ship and other factors but is often around 50,000 litres for a medium-sized ship and up to 2,000,000 litres for a large ship.

Table 2. UV/oxidation of 1.0 mg/l tributyltin acetate in deionised water and pH neutral.

<i>H₂O₂ 42%_w (ml/l)</i>	<i>Half life (minutes)</i>
0.05	0.68
0.1	0.63
0.3	0.37
0.5	0.43
1.0	0.49
5.0	0.97

Therefore, about 40 litre of hydrogen peroxide would be needed for a medium ship, but up to 666 litres may be needed to treat the waste produced from a large ship. Therefore, for scale-up purposes an ozone generator may be more practical.

One of the common limiting factors with reactions involving light is the effect turbidity may have on the process, by shadowing the reaction. A series of experiments were performed with waste water collected from dockyards and slipways around Australia where ships hulls painted with TBT anti-fouling paints were being hydroblasted. Selections of these experiments are presented in Table 3. Some of these were given different pretreatments to remove solids.

Table 3. Half lives of various waste-water samples

Sample Number	Turbidity (NTU)	Calculated Reaction Half life (minutes)
1	53.1	10.5
2	1.7	7.3
3	2	4.1
4	2.2	2.5
5	NA	2.1

Results show that high turbidity does affect the degradation half-life substantially, but that reasonable reaction rates can be obtained for real dockyard washdown wastewaters, provided some pretreatment to remove suspended solids is performed.

Further work using collected dockyard waste waters showed that a few major variables can have a large impact on the composition of the waste water and subsequently can effect the efficiency of the process. A summary of the major variables are discussed below.

- Paint composition was found to have a large impact, and numerous TBT antifouling paints are on the market. However, one particular observation was the affect paint pigment was found to have. In particular, the black TBT anti-fouling paints used on submarines produced the slowest reaction rates. It is suspected that the lack of the titanium dioxide white pigment in the black paint may explain this.
- The extent of the fouling increases the level of soluble organic compounds in the waste, which may also be degraded by hydroxyl radical, and compete with the TBT.

- As the pressure of the hydroblasting increases, more paint is removed, which results in higher strength wastes, putting more demands on the UV/oxidation process.
- How the waste is collected can also have a large impact, ie is it diluted with other wastes, is it allowed any settling, and does it pick up much additional debris.

FUTURE DIRECTIONS

DSTO is continuing to assess pretreatment options to develop a complete treatment option for dockyard wastes, and has established a partnership with Australian Water Technologies to develop and test a pilot plant based on the above scheme.

The cyclonic DAF is a new Australian invention for solids removal, which produces small air bubbles by cyclonic vortex. This reduces the need for high-pressure pumps that are required for more traditional dissolved air flotation devices. This unit will improve the economics of the process considerably, and is currently being assessed by Australian Water Technologies for the pretreatment process to remove suspended solids and turbidity.

A trial is being negotiated currently at a large Australian Dockyard.

REFERENCES

- Alzieu, C. (1991) Environmental problems caused by TBT in France: Assessment, regulations, prospects' *Mar. Environ. Res.* **32**, 7-17.
- Anon. (1998a) *Australia's Oceans Policy. 1. Commonwealth of Australia.*
- Anon. (1998a) *Australia's Oceans Policy. 2. Specific Sectoral Measures.* Commonwealth of Australia.
- ANZECC (1992) *The ANZECC Australian Water Quality Guidelines for Fresh and Marine Waters.* National Water Quality Management Strategy.
- ANZECC (1996a) *Working together to reduce impacts from shipping operations. ANZECC strategy to protect the marine environment. Volume 1 – Strategy and action plan.* Australian and New Zealand Environment and Conservation Council.
- ANZECC (1996b) *Working together to reduce impacts from shipping operations. ANZECC strategy to protect the marine environment. Volume 2 – Technical annex.* Australian and New Zealand Environment and Conservation Council.
- ANZECC (1996c) *Working together to reduce impacts from shipping operations. ANZECC strategy to protect the marine environment. Volume 3 – Analysis and evaluation of industry and community comments.* Australian and New Zealand Environment and Conservation Council.
- Batley, G E (1995) Heavy metals and tributyltin in Australian coastal and estuarine waters. In, Zann L P and Sutton, D (Eds), *State of the Marine Environment Report for Australia, Technical Annex: 2 Pollution*, pp. 63-72. Department of the Environment, Sport and Territories, Canberra.
- Batley, G.E. & Scammell, M.S. (1991) Research on tributyltin in Australian estuaries. *Appl. Organometal. Chem.* **5**, 99-105.
- Bezzobs, T. (1999) Review of the *Environment Protection (Organotin Antifouling Paint) Regulations 1989* and draft Notifiable Chemical Order impact assessment. *Publication 656.* Environment Protection Authority, State Government of Victoria.
- DEP (1996) Southern Metropolitan Coastal Waters Study (1991-1994): Final report. *Report 17.* Department of Environmental Protection, Perth, W.A.
- Duhamel, K., Blanchard, G., Dorange, G. and Martin, G. (1987) Recovery of all species from photolytic degradation of tributyltin compounds TBTX (X=Cl, OSnOBu₃). *Appl. Organometal. Chem.* **1**, 133-142.
- EPCSA (1992) *Marine Environment Protection Act. Guidelines for Licensing.* Environmental Protection Council of South Australia. Department of Environment and Planning, South Australia.

- Foale, S. (1993) An evaluation of the potential of gastropod imposex as a bioindicator of tributyltin in Port Phillip Bay. *Mar. Pollut. Bull.*, **26** (19), 546-552.
- Holmes, N. (Ed.) (1988) *Proceedings of the Conference on Organotin Materials in the Marine Environment*. Centre for Coastal Management, Northern Rivers College of Advanced Education, Lismore, NSW.
- Kohn, A.J. & Almasi, K.N. (1993) Imposex in Australian Conus. *J. Mar. Biol. Ass. U.K.* **73**, 241-244.
- Komora, F. and Popl, M. (1978) The resistance of bis-tributyltin oxide to oxidation and elevated temperatures. Multilingual Services Division, Canada. Unedited translation from: *Holztechnologie* **19** (3), 145-147.
- Lewis, J.A. (1988) Organotin antifouling paints and the environment. *Surface Coatings Aust.* **25** (11), 18-25.
- Lewis, J.A. (1993) Antifouling technology and the environment. *Proceedings, Maritime Technology, 21st Century Conference, Melbourne*, 1, Section 2.1x.
- Lewis, J.A. (1998) Marine biofouling and its prevention on underwater surfaces. *Materials Forum*, **22**, 41-61.
- Maltz, A. (1988) Assessment of organotin compounds, especially tributyltin compounds used as antifoulants. *Environmentally Hazardous Chemicals Act, 1985: Assessment Report*. State Pollution Control Commission, New South Wales.
- Matthews, R.W. (1983) Hydroxylation reactions induced by near-ultraviolet photolysis of aqueous titanium dioxide suspensions. *J. Chem. Soc. Faraday Trans. 1* **80**, 457-471.
- Ministry for the Environment (1988) Report of the working party reviewing the use of antifoulants containing organotins in New Zealand. Ministry for the Environment, Wellington, New Zealand.
- Nias, D.J., McKillup, S.C. & Edyvane, K.S. (1993) Imposex in *Lepsiella vinosa* from southern Australia. *Mar. Pollut. Bull.* **26** (7), 380-384.
- RAN (1994) *ABR 19 - RAN Painting Manual, Volume 2*. Department of Defence (Navy Office), Canberra, ACT
- Tsuda, T., Nakanishi, H., Morita, T. & Takebayashi, J. (1986) Simultaneous gas chromatographic determination of dibutyltin and tributyltin compounds in biological and sediment samples' *J. Assoc. Off. Anal. Chem.* **69** (6), 981-984.
- US EPA (1996) *Tributyltin Data Call In Notice*, July 29, 1986. (U.S.) Environmental Protection Agency, Washington, D.C.
- Wilson, S.P., Ahsanullah, M. & Thompson, G.B. (1993) Imposex in neogastropods: an indicator of tributyltin contamination in eastern Australia. *Mar. Pollut. Bull.* **26** (1), 44-48.

Annex 6: **Fox T.J., Beacham T., Schafran G.C., Champ M.A.:**
*Advanced technologies for removing TBT from ship washdown and
drydock runoff wastewaters,*
Proceedings of Oceans '99 Congress, p.63-71

Advanced Technologies for Removing TBT from Ship Washdown and Drydock Runoff Wastewaters

Thomas J. Fox¹, Thomas Beacham², Gary C. Schafran³, and Michael A. Champ⁴

ABSTRACT

Since July of 1999, with funding from the U.S. EPA, the State of Virginia, and a consortium of shipyards in the Norfolk, Virginia area, an extensive international search has been conducted to find or develop a treatment method or system to remove from TBT from ship hull washdown wastewaters that would normally be discharged to local water ways or to sewage treatment systems. The purpose of this research, development and demonstration project has been to achieve a reduction in wastewaters discharged from shipyards and drydocks that range from several thousand to several hundred thousand parts-per-million (ng/L) to less than 50 ng/L to protect marine resources in Chesapeake Bay.

Keywords:

Tributyltin (TBT), Discharges, NPDES Permit, Virginia DEQ, Shipyard Wastewaters, Advanced Waste Treatment, Carbon, DAF.

INTRODUCTION

TBT is highly toxic to some aquatic organisms at concentration levels measured in parts-per-trillion (ng/L). While it is used in a wide variety of industrial and commercial products, of most concern is its use in antifouling paints for ship hulls. Tributyltin was introduced as a biocide in antifouling paints over 30 years ago. It is said to be the most toxic material ever introduced deliberately by mankind into the marine environment.

In 1997, after 10 years of study, the United States Environmental Protection Agency proposed a national saltwater aquatic life criterion for TBT of 10 ng/L (62 CFR 42554, August 7, 1997). The Commonwealth of Virginia led the nation in developing a TBT standard, establishing in 1987, a surface water standard of just 1 ng/L and an NPDES discharge standard of 50 parts-per-trillion (ng/L). Virginia is the only state in the nation with a discharge standard for TBT. Some Virginia shipyards now operate under Consent Order deadlines, which mandate compliance with the 50 ng/L discharge limit by December 2001.

¹ Executive Director, Center for Advanced Ship Repair and Maintenance (CASRM), Norfolk, VA, Tel. (757) 622-2137, Fax (757) 622-2490, E-Mail: casrm@infi.net

² Environmental Manager, Lyons Shipyard, PO Box 2180, Norfolk, VA 23501, Tel. 757-622-4661, Fax. 757-623-4751, E-Mail: tbea835062@aol.com

³ Associate Professor, Old Dominion University, Civil Engineering, Kaufman Engineering Hall, Room 130, Norfolk, VA 23529, Tel. 757-683-4673, Fax. 757-683-5354, gschafra@odu.edu

⁴ President and CEO, Advanced Technology Research Project Corporation, P.O. Box 2439, Falls Church, VA 22042, Tel. (703) 237-0505, Fax (703) 241-1278, E-Mail: machamp@aol.com

The adoption of this standard has had a major impact on the Virginia ship repair industry. Shipyards generate TBT water from wash-down operations in dry-docks where fresh water is used to remove salt and slime from ship's hulls. This operation must be performed on all dry-docked ships. TBT levels in process waters from ship wash-down have been observed to be approximately 10,000 times higher than the new Virginia discharge standard. TBT is also generated from repair operations on sonar domes of US Navy surface combat ships.

This paper describes efforts by the Virginia ship repair industry to achieve compliance with the 50 ng/L discharge limit.

BACKGROUND

Between 70 and 75% of the 27,000 deep water commercial ships have hulls coated with an antifouling paint containing TBT. These paints are used because they are extremely effective for preventing marine growth on the hulls, which can reduce ship speed and increase fuel costs. TBT is highly toxic to aquatic life at very low concentrations measured in parts-per-trillion (ng/L), see Champ and Seligman (1996).

The largest source of TBT in coastal US marine waters is that leached from the hulls of the thousands of ships which visit the US ports each year to load and unload cargo. This discharge is designated as non-point source and is unregulated in the United States.

A second and lesser source (but is a point source) of TBT from ships to the marine environment is when ships are dry-docked for standard hull inspection and certification (for insurance purposes) and or repair. The first operation in dry-dock is to wash down hoses the hull with high-pressure fresh water in order to remove marine salt and slime. This operation must be done to permit inspection of the hull and coatings, and in

preparation for any hull repair work. A typical wash down job may generate over 100,000 gallons of wash wastewater, containing varying amounts of TBT from several thousand to several hundred thousand parts-per-trillion.

Virginia is the first state in the country to incorporate a numerical TBT limit for Virginia Pollution Discharge Control System (VPDES) shipyard permits. A consent order has been signed between the parties (DEQ, EPA and Shipyards) involved to meet a deadline of December 1, 2001 for Virginia shipyards for compliance with discharging water containing less than 50 ng/L of TBT. However, Newport News Shipbuilding has in its permit, compliance by June 4th, 2000.

Removing pollutants from industrial waste streams is fairly straightforward at levels of parts per million, It is much more difficult and expensive at levels of parts per billion. Purifying large quantities of water to levels of parts per trillion is a major technical challenge. At present, shipyards have no practical guidance on any technology that can be employed to meet regulatory discharge limits.

Over a period of 40 years, TBT has been the subject of many hundreds of studies that have documented the effects of TBT on different marine organisms(in different bodies of water). The effects of pH, water temperature, salinity and seasons of the year have been measured, as have the rate of decay of TBT in the environment, the fate of TBT in sediments, etc. Four international Symposia have been held related to fate and effects of TBT in the marine environment and a reference work has been published from some 40 years of studies (Champ and Seligman, 1996).

Notably missing from this body of knowledge is any work relating to the removal of TBT from industrial waste streams. There are a small number of papers relating to the fate of TBT in municipal wastewater plants using activated sludge (Fent 1996), but this involved low concentrations of TBT

(200 ng/L) in the influent water stream. Industrial waste streams from shipyards have measured TBT levels as high as 480,000 ng/L, which is known to be sufficient to kill the bacteria in activated sludge (Argaman *et al.*, 1984). Additionally, water from dry-dock wash-down operations is intermittently generated, which rules out biological processes as a viable treatment option.

There is very little published information concerning the treatment of TBT in wastewater. Shipyards have no guidance on how to treat their water to remove TBT.

VIRGINIA SHIPYARDS' APPROACH TO ACHIEVING TBT COMPLIANCE

Virginia shipyards elected to work together cooperatively to address the TBT compliance challenge. Several years ago the shipyards helped establish the Center for Advanced Ship Repair and Maintenance (CASRM) as a cooperative partnership between the industry and the College of Engineering and Technology at Old Dominion University, Norfolk, VA. The CASRM consortium has since coordinated most of the shipyards TBT research, development and demonstration projects.

CASRM first commissioned a global bibliography of scientific papers (Alden *et al.*, 1996) dealing with the adverse ecological effects of TBT. This bibliography detailed over 600 different scientific studies that defined the extent of the problem; however, there was virtually no information in the published work that could give guidance to shipyards on how to treat TBT in wash down wastewaters.

In 1997, CASRM began a project to determine the state-of-the-art technological practices regarding the reduction of TBT concentrations in wastewater (Messing *et al.*, 1997). The National Shipbuilding Research Program (NSRP) funded this project. A survey was made of shipyards,

researchers, manufacturers of TBT, industries that incorporate TBT into their products, state and federal regulatory agencies, and Regional Water Control Boards, to gain information concerning TBT disposal in waste streams.

The purpose of this study was to identify practical technologies that could be used by shipyards to remove TBT from large volumes of water to levels below 50 ng/L. This study was based on: (1) a review of scientific and engineering literature, (2) a review of U.S. Patents, and (3) a survey of manufacturers and industrial users. The study concluded:

- **There is no "off-the-shelf" technology directly applicable to shipyard waste streams that will reduce TBT levels in water below a concentration of 50 parts per trillion.**
- **Because TBT is highly attracted to particles in water, adsorption process may prove be the most effective means to reduce TBT concentration. It is suggested that technology such as Dissolved Air Floatation, and Activated Carbon Adsorption are the best candidate technologies.**

Also in 1997, in the absence of any available technology, Norfolk Shipbuilding and Drydock Corporation (NORSHIPCO), a member of the CASRM consortium, decided to determine how much progress could be made toward meeting the <50 ng/L goal using different types of standard (off the shelf) water treatment equipment. Subsequently, NORSHIPCO assembled a small industrial water treatment processing plant to conduct some preliminary studies to treat the washdown wastewater using equipment leased on a trial basis. The equipment was not properly sized for the water flow, nor was it used in an optimum way. The results were, however, sufficiently

encouraging that water treatment was repeated on a series of subsequent TBT jobs, using variations of equipment to try different alternatives.

SUMMARY OF TREATMENT STUDIES AT NORSHIPCO, 1997 AND 1998

These studies were conducted on a large floating dry-dock having a smooth cambered deck on which heavy machinery could be easily relocated. With this kind of dry-dock, ballast tanks are flooded to sink the dock, the ship to be repaired is floated into the dock, and air is pumped into the tanks to raise the dock and the ship out of water. The average size of vessels included in this study was approximately 800' long and 100' wide, and having an underwater hull area in excess of 100,000 square feet.

Washdown is the first operation to be initiated as soon as the ship is out of the water. Typically this is done manually, using a crew of about 20 laborers, and continues through several shifts for a total of about 30 hours. Each operator uses a moderate pressure water washer, using fresh water only at a rate of 4 gpm. Typical water usage on this job is 140,000 gallons. The washdown serves to remove three materials from the hull: sea salt, a wet marine slime, which has the texture and appearance of dead algae, and the top layer of antifouling paint.

After washdown, the hulls of all the ships in this study were inspected, and in every case were found to be in excellent shape with little or no damage from corrosion or marine growth. This is testimony to the efficacy of modern TBT antifouling paints. Washwater was collected by ballasting the dock in order to tilt it slightly, so that all the washwater drains to one end, where it was collected in troughs on the apron of the deck. From here the water was pumped to holding tanks to await treatment.

Figure 1 provides a flow diagram for the experimental treatment system that has been developed following the NORSHIPCO experimental water treatment studies in 97 and 98. The equipment used in the NORSHIPCO studies included: (1) Dissolved Air Flootation to remove suspended solids, (2) a sand filter to remove fine suspended solids and (3) an activated carbon bed to remove dissolved organic materials including TBT. These technologies have been included in the design of the CASRM Barge Treatment System and Process Train, see Figure 1 below.

Water samples were sent to a commercial laboratory for analysis of TBT concentration and toxicity. TBT concentrations in different water samples collected from different treatment steps over time as ship washdown wastewaters were being treated is presented in Table 1 on the next page.

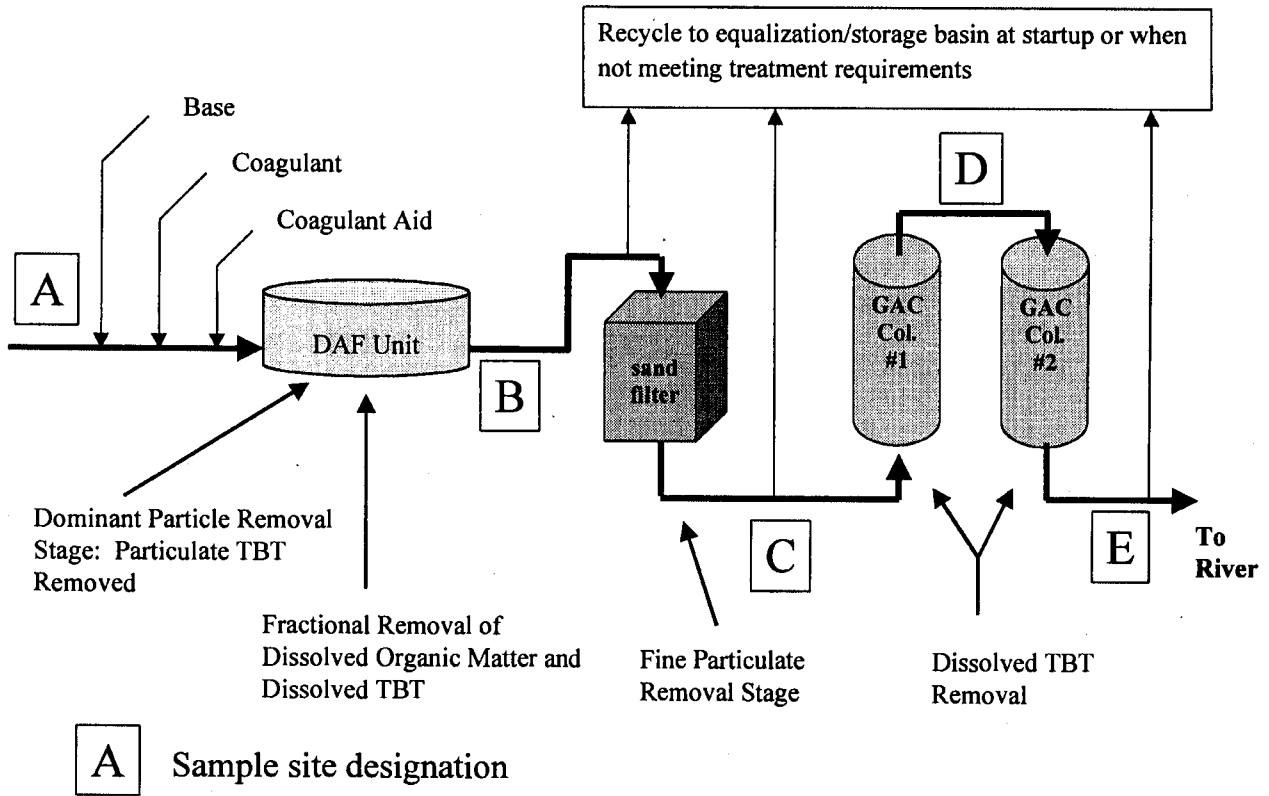

Figure 1. Schematic of the 1999 CASRM Barge Treatment Plant SYSTEM and Process Train for TBT Removal.

Table 1. Test results to remove TBT from shipyard wash water during 1997.
Data courtesy of NORSHIPCO, Norfolk, VA.

Ship	Treatment Stations	Sample	TBT Concentration (ng/L)
Fascination 4/29-30/97	DAF; Carbon(1)	Pre Carbon	180,000
		Post Carbon	310
		Post Carbon	210
		Post Carbon	2,140
MV Po Hong Yu 7/2/97	DAF; Sand; Carbon (1)	Trough	8,300
		Pre DAF	11,000
		Pre Carbon	8,500
		Post Carbon	70
Zealand Expedition 8/2/97	DAF; Sand; Carbon (1)	Pre DAF	8,100
		Pre Carbon	8,000
		Post Carbon	790
Inspiration 9/12/97	DAF; Sand; see text	Pre DAF	485,000
		Post Carbon	18,000
		Post Carbon	41
		Post Carbon	210
Ecstasy 1/30/98	DAF; Sand; Carbon (1)	Post Carbon	540

The first set of data for the cruise ship Fascination found that the TBT concentration prior to passing through the carbon bed was 190,000 ng/L. TBT levels in wash water from all ships prior to passing through carbon absorbent varied from 8,300 ng/L to 480,000 ng/L. This may reflect different levels of TBT in different types of paint.

Activated carbon is very effective in removing dissolved TBT from water. The data from the Inspiration is particularly striking. The concentration of TBT in the water stream was reduced from 480,000 ng/L to 41 ng/L by passing it through the carbon bed. This level would meet

the Virginia discharge limit goal of 50 ng/L. The key to effective TBT removal by carbon is effective removal of suspended solids by earlier stages, and providing for sufficient volume of carbon to handle the adsorption load.

It should be recognized that carbon would adsorb nearly all organic material presented to it, so it is important to reduce the presence of other organic contaminants in wastewaters as much as possible. Adsorption is a surface area phenomenon. As carbon adsorbs organic material, there is less surface area left and its adsorption efficiency drops as it becomes exhausted. Previous work by

CASRM on storm water runoff from a dry-docks suggests that non-TBT dissolved organic material may be several orders of magnitude higher than TBT concentration.

Over the five ship series, the TBT removal rate varied from 90% to 99.99%. On one occasion, the goal of <50 ng/L was achieved, but 12 hours later performance had dropped to 210 ng/L.

These tests at NORSHIPCO demonstrated the potential of a carbon based system to be able to remove TBT from wastewaters to below 50 ng/L, and focused attention on areas where further R&D was needed. A major concern was to refine and make the process more efficient and cost effective and to reduce the amount of carbon utilized and total waste residue.

The equipment utilized in the NORSHIPCO studies was not optimum; they were chosen because they were available off the shelf at the time. The DAF was rated at 25 GPM, but in order to keep up with shipyard production schedule, it was operated at rates up to 60 GPM. In addition the DAF was optimized for removal of metals (zinc

and copper), not removal of TBT. The carbon bed was also severely undersized for the water throughput used.

Another difficulty experienced during these studies was the time delay between submitting water samples and receiving TBT analysis results. The commercial laboratory chosen routinely required three weeks to report TBT numbers. In many cases, the ship had left dry-dock before TBT levels in the water samples were known. Enquiries with various laboratories revealed that TBT analysis at levels of parts per trillion is very complicated, labor intensive, and expensive at these levels. In a laboratory set up to perform TBT analysis routinely, a minimum of two days is required per sample.

It became clear during these tests that a much faster (shorter time period) method for analyzing the water effluent was required. During the shipyard tests, the equipment was set up and operated during the wash-down without any real time knowledge of the TBT level in the effluent. A rapid method to assess TBT concentration is needed for treatment system process control.

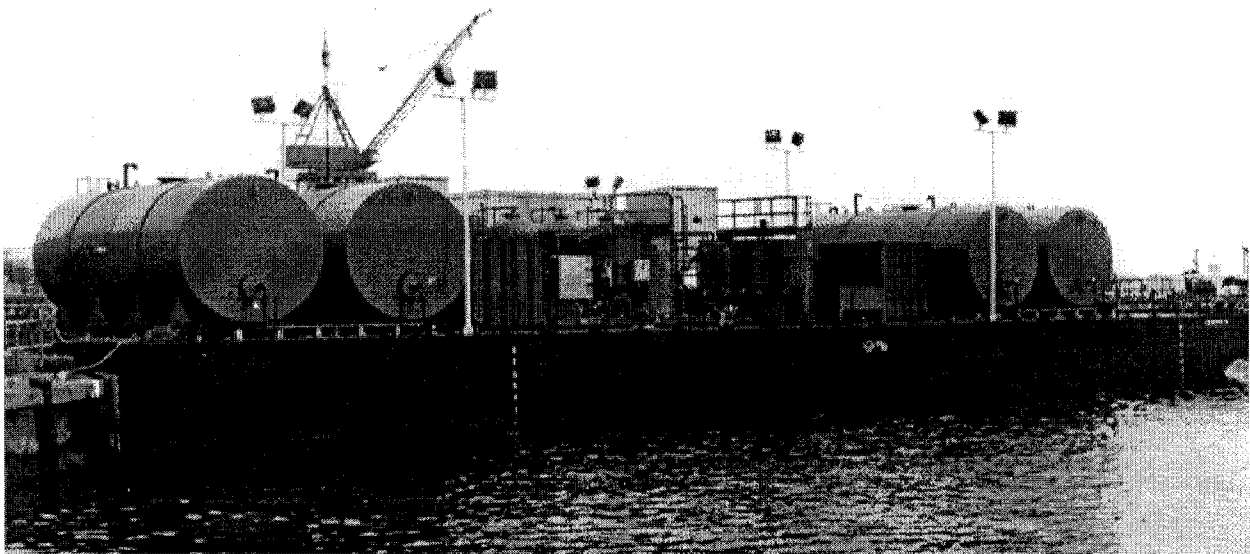

Figure 2. The CASRM Barge Treatment Plant SYSTEM and Process Train for TBT Removal.

CURRENT R&D

For the past year, the CASRM Consortium has been engaged in an intensive effort toward achieving shipyard compliance. Cooperative research and demonstration contracts from US EPA and the Virginia Department of Environmental Quality have enabled the CASRM Consortium to implement the following four-phase research and development implementation plan:

Phase 1. A full scale, fully engineered version of the 97/98 NORSHIPCO experimental system has been constructed, and deployed on a floating barge (November – December, 1999). The system, designed to treat 100 GPM, has a recycle type DAF system, a mixed media filter and two high-pressure carbon canisters. The carbon bed is sized to achieve a water-carbon contact time of over twenty-five minutes at full flow. The system is fully instrumented; operating variables are monitored and logged in real time by computer. There is provision to add other water treatment processes in the future. A photograph of the CASRM barge and water treatment system is presented in Figure 2. The System being barge mounted allows the treatment system to be moved conveniently to any dry-dock in the region where TBT washdown wastewater is being generated. The barge is completely self contained. It can be towed into place before the ship is dry docked, and can collect and process (treat) wastewater as soon as cleaning begins.

Phase 2. Laboratory analysis and bench scale tests will be used to optimize the barge based pilot plant treatment system and process and to evaluate alternative treatment processes, which may be utilized. Alternative processes include the use of oxidizers such as hydrogen peroxide and ozone, and the use of ultraviolet light to degrade TBT in wastewaters.

Phase 3. A FAST TBT Method for analysis of TBT in washdown and treated wastewaters is being

developed. The current industry standard method of measuring TBT in water at concentrations measured in parts per trillion (ng/L) is complicated, labor intensive and requires a minimum of two days per sample to complete. A Fast Method for TBT analysis is required to monitor the performance of any treatment process developed to remove TBT. The goal is to be able to measure levels as low as 30 ng/l in less than ten minutes, which is the required QL level in the Consent Agreement.

Phase 4. The results of phase one, two and three will be combined and incorporated into development of a pilot plant water treatment system. This system will be tested under real industry production situations (100,000 gallon levels in 30 hours).

It is expected that this project will result in the development of a self-contained TBT treatment System to reliably achieve less than 50 ng/L TBT effluent. Design and operating data will be used to develop a design guide for modular TBT removal systems suitable for different conditions. The results will be disseminated to industry, the scientific community and the public. A Quality Assurance Project Plan (QAPP) has been prepared (Champ et al., 1999) to obtain the highest level of QA/QC for the entire project and full verification and validation of the FAST TBT Method.

ACKNOWLEDGEMENTS

This CASRM Project is funded through a partnership by industry, academia and government (Federal and State) as a cooperative research, development and demonstration project funded by the Office of Water (U.S. Environmental Protection Agency), the Department of Environmental Quality (Commonwealth of Virginia), and a Consortium of the Norfolk area shipyards with construction and operation support from Newport News Shipbuilding and NORSHIPCO.

REFERENCES CITED

- Alden III, R.W., R.J. McDanie II, T.A. Ribeiro, L.M. Ramirez, J.H. Rose. 1996. A Literature Search for the Effects of Tributyltin on Aquatic Organisms and Current Tributyltin on Aquatic Organism and current Tributyltin Regulatory Limits Among Regulatory States of the United States. TR. No. 3008. Applied Marine Research Laboratory. Old Dominion University, Norfolk, VA 23529-0456. 157p.
- Argamen, Y., Hucks, C.E. and S.E. Shelby. 1984. The Effects of Organotin on the Activated Sludge Process. *Water Research*. **18**(5): 535-542.
- Champ, M.A. and P.F. Seligman. (Eds). 1996. *Organotin, Environmental Fate and Effects*. Chapman and Hall. London. 674p.
- Champ, M.A., G.C. Schafran, T.J. Fox, G.A. Cutter, M. Unger, and G. Salata. 1999. Quality Assurance Project Plan for the Analysis and Treatment of TBT in Waste Waters from Virginia Shipyards and Drydocks. CASRM. Norfolk, Virginia. 170p.
- de Mora, S.J., C. Stewart and D. Phillips. 1995. Sources and Rate of Degradation of Tributyltin in Marine Sediments Near Auckland, New Zealand. *Marine Pollution Bulletin*, **30**(1):50-57.
- Fent, K. 1996. Organotin Compounds in Municipal Wastewater and Sewerage Sludge: Contamination, Fate in Treatment Process and Ecotoxicological Consequences. *The Science of the Total Environment*. **185**:151-159.
- Grovhoug, J.G., P.F. Seligman, G. Vafa, and R.L. Fransham. 1986. Baseline Measurements of Butyltin in U.S. Harbors and Estuaries. *Oceans '86, Vol 4, Organotin Symposium*, Washington D.C. Vol. 4:1283-1288
- Messing, A.W., L.M. Ramirez and T.J. Fox. (1998). A Review to Determine State-of-the-Practice Treatment Technologies for Reducing Concentrations of Organotin Compounds in Wastewater. *National Shipbuilding Research Program Report*. Ann Arbor Michigan. 57p.
- Page, D.S., C.C. Ozbal and M.E. Lamphear. 1996. Concentration of Butyltin Species in Sediments Associated with Shipyard Activities. *Environmental Pollution*. **81**(2):237-243.
- Seligman, P.F. (1984) "Fate and Effects of Organotin Antifouling Leachates in the Marine Environment." Bethesda, MD.

Annex 7: **Ashcroft P.L., Abel D.:**
Process Water Treatment for the removal of TBT in ship wash down
wastewaters,
Proceedings of Oceans '99 Congress, p.73 - 75

Process Water Treatment for the Removal of TBT in Ship Washdown Waste Waters

Peter L. Ashcroft¹ and David Abel².

ABSTRACT

A consortium is being created to commercialize a cost and environmentally beneficial water treatment process for the removal of TBT from ship washdown wastewaters developed in the UK at the University of Sunderland. The solvent extraction process, initially developed through funding from EC MEDSPA project, is to be exploited by a new group set up to introduce the technology to a wide range of industrial processes. A key target, for which the system was developed is treatment of TBT contaminated dockyard process effluent. The technology has been proven in one pass to reduce TBT levels from 2mg.l^{-1} to 200ng.l^{-1} . The estimated cost for each metric tonne of effluent treated is £4 (<\$7).

KEYWORDS: Tributyl-tin, wastewaters, ship washdown wastewaters, treatment, drydocks, shipyards.

INTRODUCTION

The development, testing and commercialization of this technology has been over a ten year period:

- 1991 University of Sunderland proposal
- 1992 EC MEDSPA support
- 1995 Pilot scale process demonstrated
- 1996 Joint-venture formed for scale-up
- 1997 10te.hr^{-1} system proved

The extraction process is carried out by dispersion of an appropriate solvent in the process water stream. The dispersion provides an environment for mass transfer of the target species into the extraction phase (solvent). To achieve this end the solvent is dispersed to form a high surface area to enable mass transfer to take place. Once the extraction process is complete the solvent dispersion is coalesced for post-extraction treatment of the waste stream.

The development includes a patented process for development and maintenance of a large surface area at which interface the mass transfer takes place. The final part of the process involves the coalescence of the dispersed phase for separation and recovery / disposal of the target pollutant.

The new consortium expects to have a laboratory / pilot installation available early in 2000. This will be used to further evaluate performance and design the commercial units to be made available later in 2000.

OBJECTIVES & PROCESS OPERATION

The consortium objectives are to promote and exploit the technology because of what are seen as substantial process benefits. These are clearly apparent when the process is compared to alternative technologies applied to TBT and similar water treatment problems.

The benefits of this technology include:

- a) minimization of waste volume;
- b) no generation of solid waste;
- c) avoidance of civil works;
- d) design as a mobile, modular system;
- e) parallel operation with waste production;
- f) elimination of need for process water storage;
- g) minimization of operating costs;
- h) adaptability for future changes in standards;
- i) applicability to other pollutant streams; and
- j) robust construction for industrial operation.

A major benefit is a massive volume reduction in terms of the waste stream from the process. The operating parameters require a solvent volume amounting to between 2 and 4% of the process mass. If a nominal $10\text{te}\cdot\text{hr}^{-1}$ is processed during a

10-hour period 100te of process water will be treated. The hold up volume of the system pipe work will be some hundreds of liters. This gives an average requirement substantially below 100 liters of extraction fluid. The external hold up volume where post processing of the extraction fluid may take place could lead to a parallel solvent reservoir of perhaps 200 liters to allow for any secondary processing. This will not necessarily change even if the unit is operated continuously for days or weeks.

In practice it has been identified that a wide range of oils are suitable as extraction solvent. It may be acceptable locally to use an existing waste oil stream to effectively avoid creation of an additional waste stream.

The process is viewed as a series of separate modules. The individual components are illustrated in the schematic presented below in Figure 1.

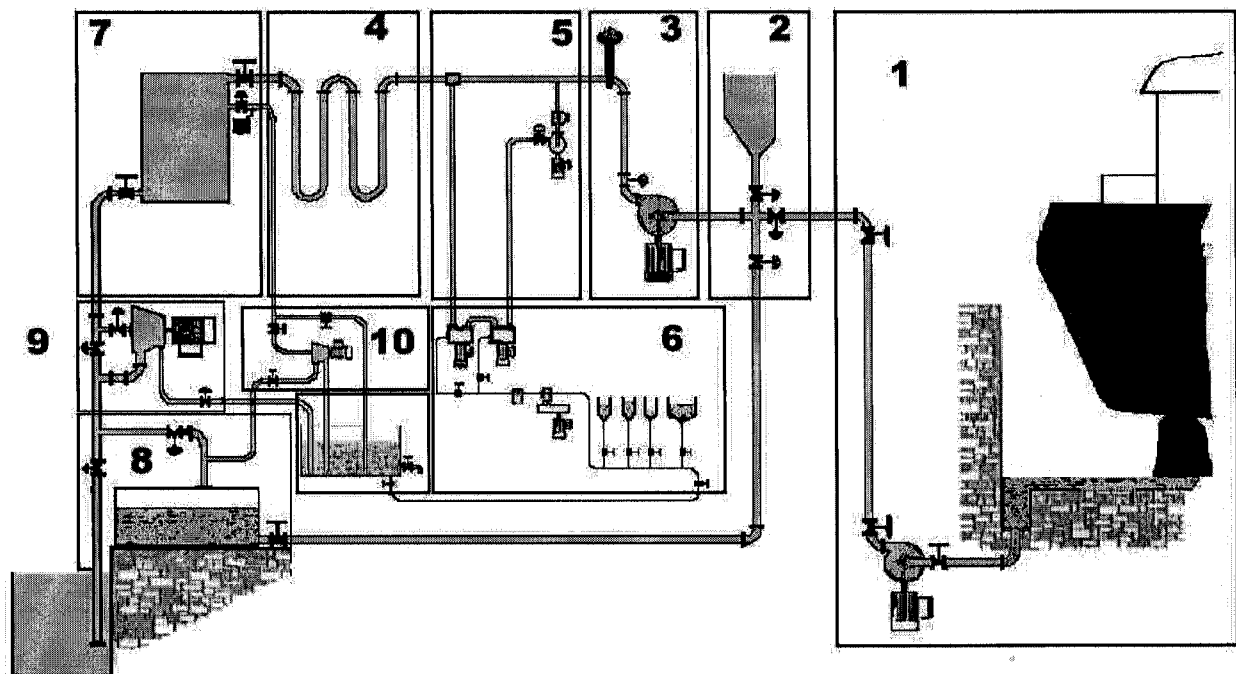

Figure 1. A schematic illustrating the components of the technology. See following text for legend.

The first module [1] includes a transfer pump to take the process stream from the source and will include primary screening to remove solids etc. The front end of the process unit will have a reservoir [2] to allow priming of the system prior to initiating treatment. This primary fluid stream will then be pumped [3] to the "reactor pipe work" [4]. A controlled fraction of the main flow is diverted [5] to the dosing system [6]. In this module, a concentrate is made with the extraction solvent being dispersed in the process liquid. The system will be capable of admitting any extraction solvent appropriate to the target pollutant.

The "reaction" module [4] maintains the dispersion of extraction solvent while the pollutant is extracted. The treated mixture then enters the separation module [7] where the solvent and cleaned water streams are separated. The water can go for discharge [8] or "polishing" [9] according to local quality standards. The oil stream is collected [10] for reuse, treatment or disposal according to local requirements. The solvent collection module can include secondary processing, recycling or simple discharge facilities.

PROTOTYPE PERFORMANCE

The technology has been proven to operate in an industrial environment with the ability to reduce TBT levels from 2mg.l⁻¹ to 200ng.l⁻¹. The use of repeat extraction modules will give progressive further reduction with no effective increase in waste volume produced. The estimated cost for each metric tonne of effluent treated is £4 (<\$7).

REFERENCES CITED

EC MEDSPA. 1991. Contract No. 91-1/UK 002/INT/06. GB Patent (Pending) 97 01894.

¹Kestrel Services 2000 Ltd., Wallsend Research Station, Davy Bank, Wallsend, NE28 6UZ, UK. Tel. +44 (0)191 234 0800, Fax +44 (0)191 234 1331, Mobile: +44 (0)777 1661 809, E-Mail: information@kestrel2000.co.uk

²Ecology Centre, University of Sunderland, Sunderland, SR1 3SD, U.K, Tel: +44 191515-2533, Fax +44 191 515-2534, E-Mail: david.abel@sunderland.ac.uk